

OSMT™ Interconnect System Surface Mount Coaxial Connectors

M/A-COM's OSMT Interconnect System is designed to meet the growing demand for surface mount RF connector technology. The OSMT occupies less printed circuit board (PCB) real estate than conventional through hole coaxial connectors. An innovative microstrip mounting pattern and plug receptacle design ensure reliable grounding and PCB retention characteristics. The OSMT Interconnect System also allows closer PCB pitch/spacing, standing a mere 4.2mm (fully mated height) off the board. A new higher cable retention plug receptacle has been added to the OSMT product family. This new design addresses applications where force is applied to the mated connector interface as a result of cable flexure between boards or around other PCB components.

These enhancements and features have been built into the OSMT design to provide the performance of much larger industry standard connectors. The OSMT Interconnect System consistently achieves broad band electrical performance through 6 GHz with a maximum VSWR of 1.20:1 at 2 GHz and 1.40:1 at 6 GHz. This broad band performance establishes a reliable interface that can be utilized for future system upgrades without concerns for performance degradation.

The OSMT plug receptacle is designed for high volume assembly using surface mount technology and is available in tape and reel packaging for automated pick and place board assembly. The mating cable jack is available terminated to a specially designed coax cable as either a pigtail, jumper or standard interseries connector assembly to meet your needs.

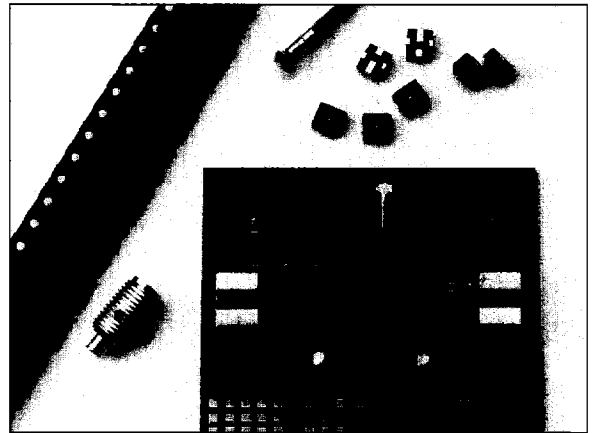

Specially designed engage/disengage tooling is available to ensure proper alignment of the OSMT interface during assembly. The new higher retention plug receptacle can be hand engaged as a result of a unique lead-in chamfer design which also aligns the contacts prior to mating to ensure mechanical integrity. Interface durability is rated at 100 mating cycles.

M/A-COM's OSMT Interconnect System is ideal for surface mount applications in telecommunications, GPS, consumer and automotive electronics. The OSMT provides versatile RF solutions for next generation interconnect needs. Please call your local Sales or Distribution office for additional information and qualification samples today.

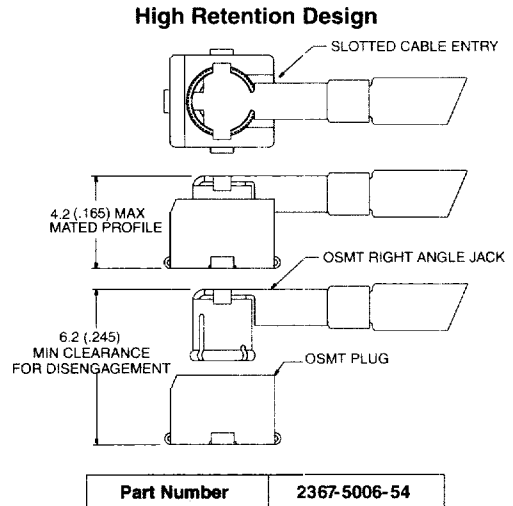
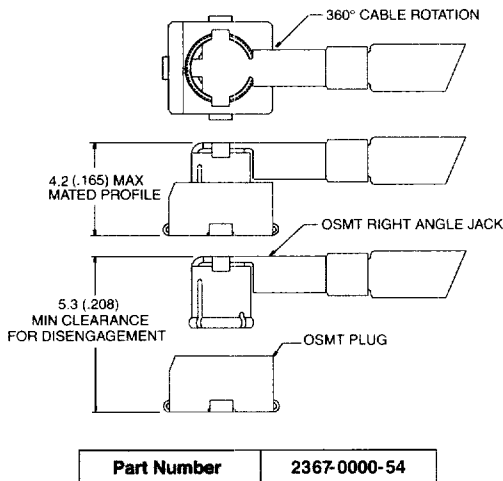

Decimal inch equivalents are shown in parentheses for general information only.

OSMT Specifications

Requirement	Detail
General	
Materials	
OSMT Plug	Housing: Polyphenylene Sulfide Contacts: Copper alloy
OSMT Cable Jack	Outer Contact: Beryllium Copper Inner Contact: Beryllium Copper Dielectric: Polypropylene, GF
Finish	Plug and cable jack - Contacts: Gold plate over nickel plate

Electrical	
Frequency	dc - 6 GHz
Nominal Impedance	50 ohms
Voltage Rating	250 Volts (VRMS Maximum) @ Sea Level
VSWR (Mated Connectors Only)	1.20:1 Maximum @ 2 GHz 1.40:1 Maximum @ 6 GHz
Insulation Resistance	1000 Megohms Minimum
Dielectric Withstanding Voltage	500 Volts (VRMS Minimum) @ Sea Level
Contact Resistance (Connectors Only)	
Center Contact	15 milliohms Maximum
Outer Contact	10 milliohms Maximum
Insertion Loss (Connectors Only)	.15dB Max. @ 6 GHz

Mechanical	
Connector Durability	100 mating cycles
Tape/Reel Packaging (Plug)	12mm per EIA-481
Force to Engage	4.0 lbs. Max. (2.5 lbs. typ.)
Force to Disengage	4.5 lbs. Max. (3.0 lbs. typ.)

Environmental	
Temperature Rating (Mated Pair)	PVC Flexible Cable: -40°C (-40°F) to +105°C (221°F) FEP Flexible Cable: -40°C (-40°F) to +125°C (257°F)
Resistance to Solder Heat	Infrared, convection and vapor phase solderable (plug only). Maximum reflow time/temperature not to exceed 260°C for 3 minutes.

Cable Specifications¹		
Materials	PVC Flexible Cable (105°C)	FEP Flexible Cable (200°C)
Jacket:	Polyvinyl Chloride	Fluorinated Ethylene Propylene
Shield:	Silver Plated Copper Wire, 38 AWG, 90% Min. Coverage	Silver Plated Copper Wire, 38 AWG, 90% Min. Coverage
Dielectric:	PFA or FEP	PFA or FEP
Center Conductor:	Silver Plated Copper Clad Steel, 30 AWG	Silver Plated Copper Clad Steel, 30 AWG
Minimum Bend Radius	9.5mm (.375 inch)	9.5mm (.375 inch)
Insertion Loss (PVC and FEP Cable Only)	0.4 dB/ft., 1.3d B/m @ 500 MHz 0.6 dB/ft., 2.0 dB/m @ 1 GHz 0.9 dB/ft., 3.0 dB/m @ 2 GHz	1.3 dB/ft., 4.3 dB/m @ 4 GHz 1.7 dB/ft., 5.6 dB/m @ 6 GHz
Center Conductor Resistance (PVC and FEP Cable Only)	.26 Ohms per foot average.	

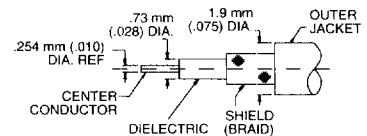

1. M/A-COM has design control and all data contained herein is subject to change without notice.

Decimal inch equivalents are shown in parentheses for general information only.

OSMT Surface Mount Coaxial Connectors

Straight SMT PCB Mount Plug Receptacles

Multi-directional cable entry, 360° rotation. Recommended for use in passive cable applications or with supplementary cable tie-downs.

Part Number	Packaging	Quantity
2367-0000-54	Bulk	customer specified
2367-5001-54	178mm (7.0 inches) Dia. Taping	800 pcs/reel
2367-5002-54	330mm (13.3 inches) Dia. Taping	3000 pcs/reel

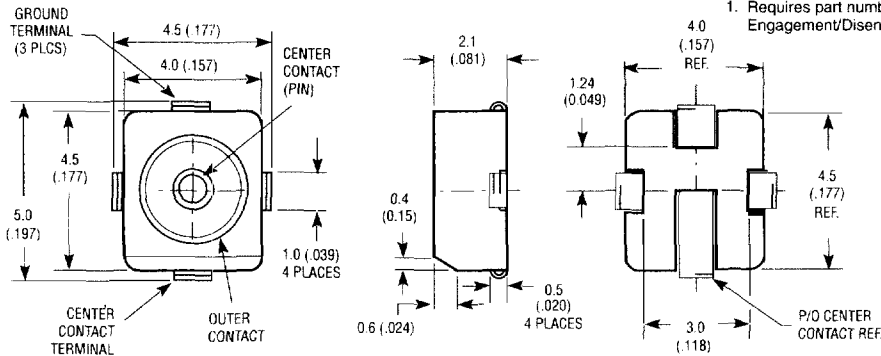

1. Requires part number 2598-5342-54 Engagement/Disengagement Tool.

Slotted single direction cable entry. Recommended for use in applications where bending forces may be applied to the cable.

Part Number	Packaging	Quantity
2367-5006-54	Bulk	customer specified
2367-5015-54	178mm (7.0 inches) Dia. Taping	600 pcs/reel
2367-5016-54	330mm (13.3 inches) Dia. Taping	2500 pcs/reel

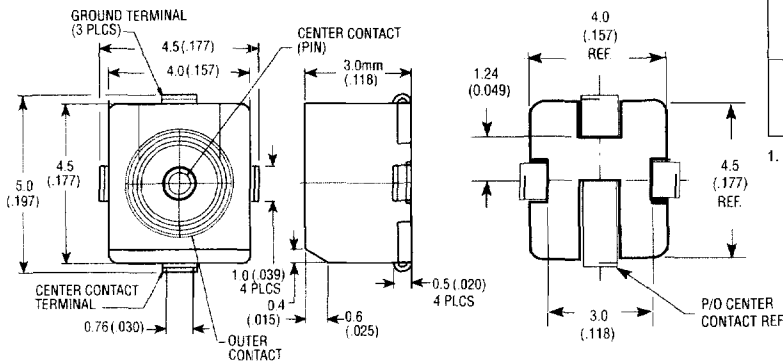

1. Requires part number 2598-5401-54 Disengagement Tool. Engagement requires no tooling.

OSMT Surface Mount Coaxial Connectors

Recommended Mounting Pattern for Microstrip Line

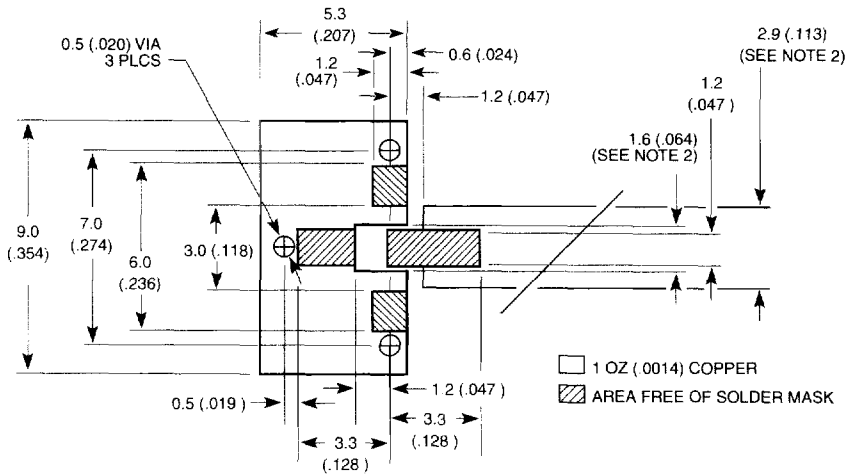

Notes:

1. Printed wiring board material: glass epoxy FR-4 or similar, relative permittivity: 4.8, 1 oz. copper clad both sides.
2. These dimensions valid for 1.6 (.062) board thickness.
3. Decimal inch equivalent (to the nearest 0.001 inch) are shown in parentheses for general information only.
4. Mounting pattern is utilized for both plug receptacles.

Right Angle Jack to Jack Cable Assembly

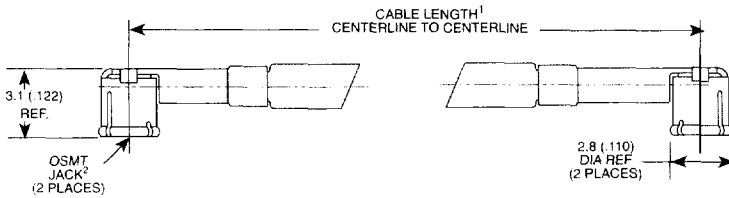

Part Number		Cable Length¹ mm (Inches)
PVC Flexible Cable (105°C)	FEP Flexible Cable (200°C)	
9950-1100-23	9952-1100-23	100 (4)
9950-1200-23	9952-1200-23	200 (8)
9950-1305-23	9952-1305-23	305 (12)

1. Consult factory for non-standard cable lengths.
Cable length tolerance: 50-2000mm: \pm (2mm +1% of cable length)
2. Connector centerlines align $\pm 30^\circ$ as shown for lengths of 165mm (6.5 in.) or less. Cable assemblies over 165mm (6.5 in.) have randomly aligned connectors.

Decimal inch equivalents are shown in parentheses for general information only.

OSMT Surface Mount Coaxial Connectors

Right Angle Jack to Jack Cable Assembly 180° Offset

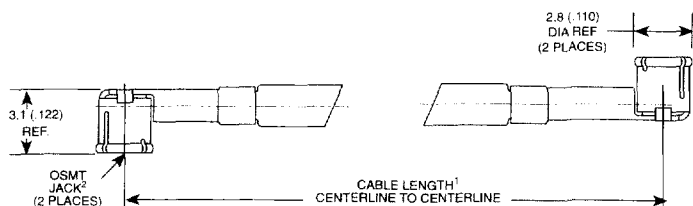

Part Number¹		Cable Length³ mm (Inches)
PVC Flexible Cable (105°C)	FEP Flexible Cable (200°C)	
9950-3100-23	9952-3100-23	100 (4)
9950-3200-23	9952-3200-23	200 (8)
9950-3305-23	9952-3305-23	305 (12)

1. Consult factory for non-standard cable lengths.
2. Connector centerlines align 180° ± 30° as shown.
3. Cable length tolerance: 50-2000mm: ± (2mm +1% of cable length)

Inter-Series Cable Assemblies

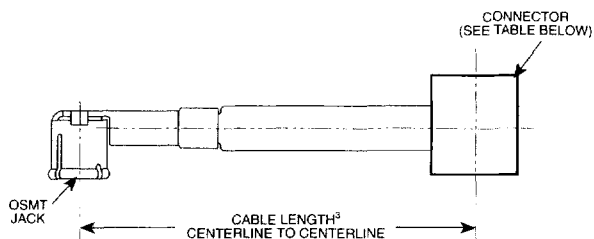

Part Number¹		Cable Length² mm (Inches)
PVC Flexible Cable (105°C)	FEP Flexible Cable (200°C)	
9950-4100-XX	9952-4100-XX	100 (4)
9950-4200-XX	9952-4200-XX	200 (8)
9950-4305-XX	9952-4305-XX	305 (12)

1. To order, replace XX in part number with appropriate digits from table indicating connector choice.
2. Connectors are randomly aligned.
3. Consult factory for non-standard cable lengths.
Cable length tolerance: 50-2000mm: ± (2mm +1% of cable length)

Description	-XX
SMA Straight Plug (Male) Crimp to OSMT Right Angle Jack	01
SMA Straight Jack (Female) Crimp to OSMT Right Angle Jack	02
SMA Bulkhead Feedthrough Jack (Female) Crimp to OSMT Right Angle Jack	03
SMA Flange Mount Jack (Female) Crimp to OSMT Right Angle Jack	04
SMB Straight Jack (Male) Clamp to OSMT Right Angle Jack	05
SMB Straight Jack (Male) Crimp to OSMT Right Angle Jack	06
SMB Straight Plug (Female) Clamp to OSMT Right Angle Jack	07
SMB Straight Plug (Female) Crimp to OSMT Right Angle Jack	08
SMB Bulkhead Feedthrough Jack (Male) Clamp to OSMT Right Angle Jack	09
SMB Bulkhead Feedthrough Jack (Male) Crimp to OSMT Right Angle Jack	10

Description	-XX
SMC Straight Plug (Female) Clamp to OSMT Right Angle Jack	11
SMC Straight Plug (Female) Crimp to OSMT Right Angle Jack	12
SMC Bulkhead Feedthrough Jack (Male) Clamp to OSMT Right Angle Jack	13
SMC Bulkhead Feedthrough Jack (Male) Crimp to OSMT Right Angle Jack	14
OSX Straight Plug (Male) Crimp to OSMT Right Angle Jack	15
OSX Right Angle Plug (Male) Crimp to OSMT Right Angle Jack	16
BNC Straight Plug (Male) Crimp to OSMT Right Angle Jack	17
TNC Straight Plug (Male) Crimp to OSMT Right Angle Jack	18
TNC Bulkhead Feedthrough Jack (Female) Crimp to OSMT Right Angle Jack	19

Finish: SMA. Passivated stainless steel; SMB and SMC, gold plate; OSX, TNC and BNC; nickel plate.
Connectors listed above are standard M/A-COM products and have not been impedance matched to the OSMT cable.

Decimal inch equivalents are shown in parentheses for general information only.

Right Angle Jack Cable Pigtail

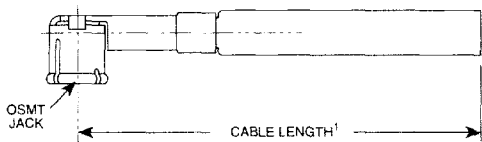

Note: To avoid damaging the cable, minimize time at temperature while soldering and/or heat shrinking connector to the cable.

Part Number		Cable Length ¹ mm (Inches)
PVC Flexible Cable (105°C)	FEP Flexible Cable (200°C)	
9950-2100-23	9952-2100-23	100 (4)
9950-2200-23	9952-2200-23	200 (8)
9950-2305-23	9952-2305-23	305 (12)

1. Consult factory for non-standard cable lengths.
Cable length tolerance: 50-2000mm: ± (2mm +1% of cable length)

SMA Straight Plug (Male) to OSMT Right Angle Jack Recommended for Customer System Verification

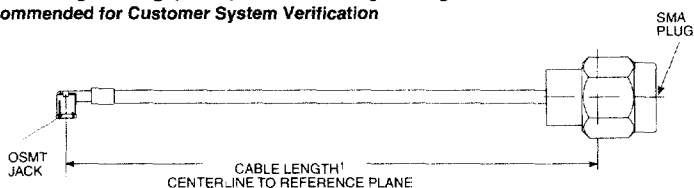

Finish: SMA, Passivated stainless steel body and gold plated center contact.

Part Number	Cable Length ¹
9950-4200-01	200mm (8 in.)

Engagement/Disengagement Tool

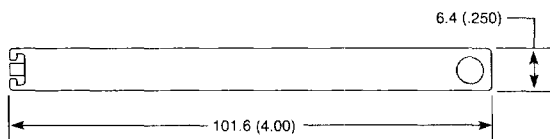

Part Number	2598-5342-54
-------------	--------------

See Application Notes for instructions.
For use with 2637-0000-54

Disengagement Tool



Part Number	2598-5401-54
-------------	--------------

See Application Notes for instructions.
For use with 2637-5006-54

Decimal inch equivalents are shown in parentheses for general information only.

OSMT Adapters

OSMT Plug to SMA Jack Adapter

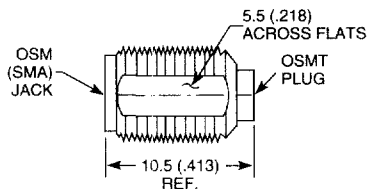

Part Number	2382-2240-00
-------------	--------------

OSMT Plug to SMA Plug Adapter

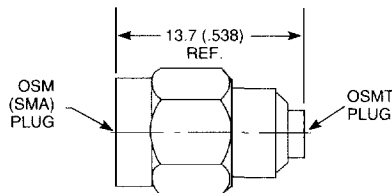

Part Number	2381-2241-00
-------------	--------------

OSMT Jack to SMA Jack Adapter

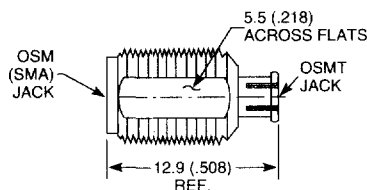

Part Number	2380-2240-00
-------------	--------------

OSMT Jack to SMA Plug

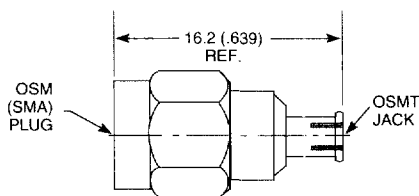

Part Number	2382-2241-00
-------------	--------------

Decimal inch equivalents are shown in parentheses for general information only.

Packaging

- Bulk Packed or Packaged in Plastic Carrier Tape on a Reel
- Available on 178mm/800 pc or 300mm/3000 pc Plastic Reel
- Sealed Plastic Carrier Tape in Accordance with EIA-481-1
- Conductive Anti-static Tape Material To Prevent Static Charge Entry to Electronic Assembly or Equipment
- Recommended Storage Temperature of Plastic Carrier Tape: 40°C (140°F), 50% Relative Humidity Max.

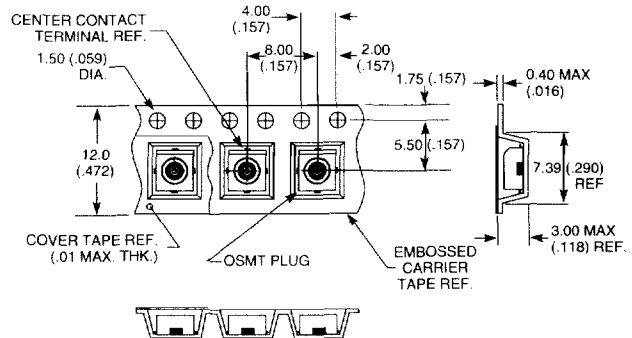

Figure 1
OSMT Surface Mount Plug Receptacle
Tape Package Detail Dimensions and Orientation

Automatic Placement

The OSMT surface mount plug receptacle is compatible with automatic placement equipment utilizing pneumatic (vacuum) part pick-up. Vacuum nozzle configuration can vary. Typical configurations follow:

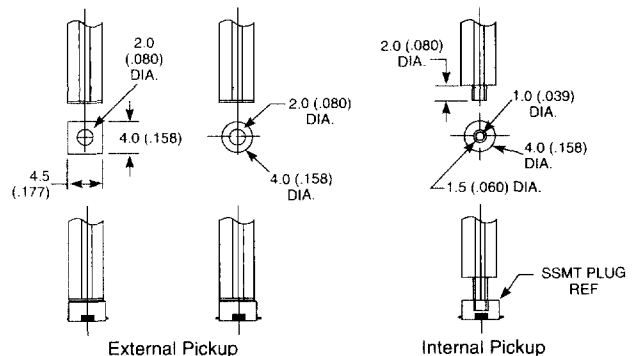

Figure 2
Typical Pneumatic Nozzle

Nozzle vacuum should be 15-30 inch Hg.
Component placement pressure should not exceed 400g.
Internal pick-up recommended for use with plug receptacle 2367-5006-54

Decimal inch equivalents are shown in parentheses for general information only.

Automatic Placement cont'd.

Alignment/centering grippers should contact sides of plug above contact leads as shown below:

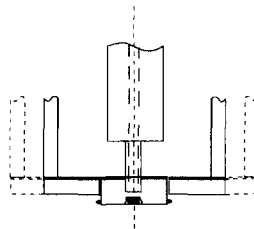

Figure 3
Typical Alignment/Centering Grippers

Alignment/centering gripper pressure should not exceed 400g.

Soldering

OSMT plug receptacles are designed for reflow soldering processes, however excellent results can still be achieved using manual soldering. Flow (wave) soldering is not appropriate for this device.

The type of solder paste selected for reflow soldering is generally a function of many factors relative to the overall system (PWA*) design. Most applications will use common electronic grade solders such as: 63/37, 60/40 or 62/36/2 with mild rosin/resin fluxes. Metal content of the paste for screen and/or stencil applications is generally 85-90% by weight, slightly lower for nozzle dispensing applications.

When screening or stenciling, solder paste thickness of .15mm (.006 inch) to .25mm (.010 inch) is recommended.

OSMT plug receptacles can be reflow soldered using infrared (IR), convection or vapor phase (VP) heating equipment. It is recommended that peak reflow temperature be approximately 10-30°C (20-55°F) above solder liquidus temperature. Typical reflow temperature profiles are shown below:

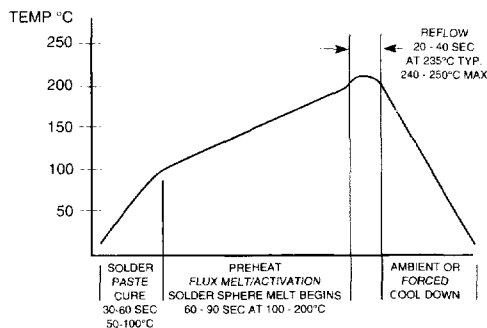

Figure 4
Typical Infrared and Convection Heating/Soldering Profile

* Printed Wiring Assembly

Decimal inch equivalents are shown in parentheses for general information only.

Soldering cont'd.

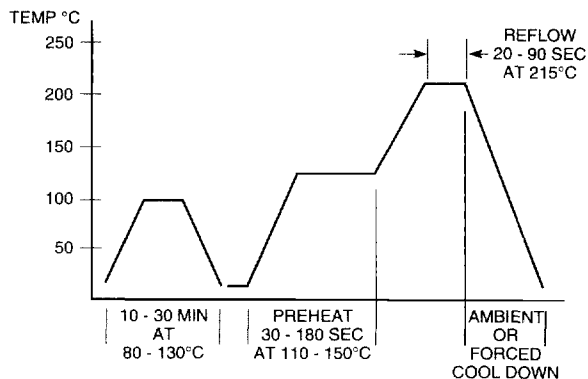

Figure 5
Typical Vapor Phase Heating/Soldering Profile

Post-Solder Cleaning

A 15-40 watt max. fine point tip soldering iron is recommended for manual soldering. Soldering iron tip temperature should not exceed 350-370°C. Lengthy application of heat and/or direct contact of the iron tip with the plastic housing should be avoided. The flux core solder (i.e.; 63/37 RMA, 62/36/2 RMA) is recommended. The center contact pad reflows easiest because of relatively low thermal mass, therefore, the center contact lead should be soldered first to minimize connector "skating".

OSMT plug receptacles can withstand most electronics grade cleaning agents including: high temperature water/aqueous cleaners, ethanol, methanol, MEK, acetone, 1,1,1-trichloroethane, trichloroethylene, perchloroethylene, chlorofluoro-carbon (CFC) solvents, isopropanol, dichlorofluoroethane, and blends. The OSMT cable jacket can also withstand mild exposure to the above listed cleaning agents.

Decimal inch equivalents are shown in parentheses for general information only.

Engagement/Disengagement Tool

Part Number 2598-5342-54

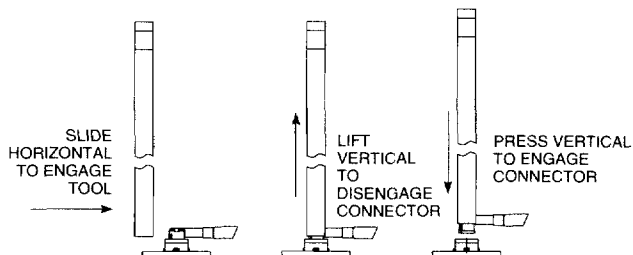

Note: Use Engagement/Disengagement Tool during mating to assure proper plug to jack alignment.

Figure 6
Use of Engagement/Disengagement Tool

Disengagement Tool

Part Number 2598-5401-54

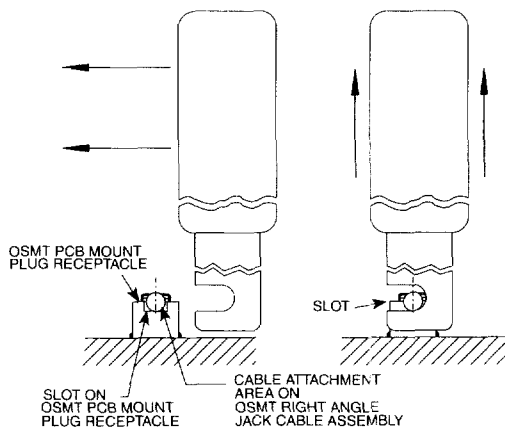

Instructions:

1. Slide slot in disengagement tool onto cable attachment area of OSMT cable assembly as shown.
2. Pull disengagement tool in a vertical direction until OSMT right angle jack releases from the OSMT plug receptacle.

Note: After manual engagement, insure the right angle cable jack is fully bottomed by applying light pressure to the top surface.

Figure 7
Use of Disengagement Tool

Decimal inch equivalents are shown in parentheses for general information only.