

## Linear Systems replaces discontinued Siliconix 2N5018

### The 2N5018 is a single P-Channel JFET switch

This p-channel analog switch is designed to provide low on-resistance and fast switching.

The TO-92 provides a low cost option and ease of manufacturing.

(See Packaging Information).

#### 2N5018 Benefits:

- Low Insertion Loss
- No offset or error voltage generated by closed switch
- Purely resistive

#### 2N5018 Applications:

- Analog Switches
- Commutators
- Choppers

#### FEATURES

DIRECT REPLACEMENT FOR SILICONIX 2N5018

ZERO OFFSET VOLTAGE

LOW ON RESISTANCE

$$r_{DS(on)} \leq 75\Omega$$

#### ABSOLUTE MAXIMUM RATINGS

@ 25°C (unless otherwise noted)

#### Maximum Temperatures

Storage Temperature

$$-55^{\circ}\text{C to } +200^{\circ}\text{C}$$

Operating Junction Temperature

$$-55^{\circ}\text{C to } +200^{\circ}\text{C}$$

#### Maximum Power Dissipation

Continuous Power Dissipation

$$500\text{mW}$$

#### MAXIMUM CURRENT

Gate Current (Note 1)

$$I_G = -50\text{mA}$$

#### MAXIMUM VOLTAGES

Gate to Drain Voltage

$$V_{GDS} = 30\text{V}$$

Gate to Source Voltage

$$V_{GSS} = 30\text{V}$$

#### 2N5018 ELECTRICAL CHARACTERISTICS @ 25°C (unless otherwise noted)

SYMBOL	CHARACTERISTIC	MIN	TYP.	MAX	UNITS	CONDITIONS
$BV_{GSS}$	Gate to Source Breakdown Voltage	30	--	--	V	$I_G = 1\mu\text{A}, V_{DS} = 0\text{V}$
$V_{GS(off)}$	Gate to Source Cutoff Voltage	--	--	10		$V_{DS} = -15\text{V}, I_D = -1\mu\text{A}$
$V_{DS(on)}$	Drain to Source On Voltage	--	--	-0.5		$V_{GS} = 0\text{V}, I_D = -6\text{mA}$
$I_{DSS}$	Drain to Source Saturation Current (Note 2)	-10	--	--	mA	$V_{DS} = -20\text{V}, V_{GS} = 0\text{V}$
$I_{GSS}$	Gate Reverse Current	--	--	2	nA	$V_{GS} = 15\text{V}, V_{DS} = 0\text{V}$
$I_{D(off)}$	Drain Cutoff Current	--	--	-10	$\mu\text{A}$	$V_{DS} = -15\text{V}, V_{GS} = 12\text{V}$
$I_{DGO}$	Drain Reverse Current	--	--	-2		$V_{DS} = -15\text{V}, V_{GS} = 7\text{V}$
$r_{DS(on)}$	Drain to Source On Resistance	--	--	75	$\Omega$	$I_D = -1\text{mA}, V_{GS} = 0\text{V}$

#### 2N5018 DYNAMIC ELECTRICAL CHARACTERISTICS @ 25°C (unless otherwise noted)

SYMBOL	CHARACTERISTIC	MIN	TYP.	MAX	UNITS	CONDITIONS
$r_{DS(on)}$	Drain to Source On Resistance	--	--	75	$\Omega$	$I_D = 0\text{A}, V_{GS} = 0\text{V}, f = 1\text{kHz}$
$C_{iss}$	Input Capacitance	--	--	45	pF	$V_{DS} = -15\text{V}, V_{GS} = 0\text{V}, f = 1\text{MHz}$
$C_{rss}$	Reverse Transfer Capacitance	--	--	10		$V_{DS} = 0\text{V}, V_{GS} = 12\text{V}, f = 1\text{MHz}$

#### 2N5018 SWITCHING CHARACTERISTICS @ 25°C (unless otherwise noted)

SYMBOL	CHARACTERISTIC	UNITS	CONDITIONS
$t_{d(on)}$	Turn On Time	15	$V_{GS(L)} = 12\text{V}$ $V_{GS(H)} = 0\text{V}$ See Switching Circuit
$t_r$	Turn On Rise Time	20	
$t_{d(off)}$	Turn Off Time	15	
$t_f$	Turn Off Fall Time	50	

Note 1 - Absolute maximum ratings are limiting values above which 2N5018 serviceability may be impaired.

Note 2 - Pulse test:  $PW \leq 300\mu\text{s}$ , Duty Cycle  $\leq 3\%$

#### 2N5018 SWITCHING CIRCUIT PARAMETERS

$V_{DD}$	-6V
$V_{GG}$	12V
$R_L$	910 $\Omega$
$R_G$	220 $\Omega$
$I_{D(on)}$	-6mA

Available Packages:

2N5018 in TO-92  
2N5018 in bare die.

Please contact Micross for full package and die dimensions

TO-92 (Bottom View)

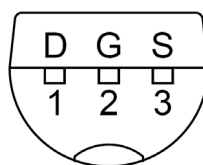

#### SWITCHING TEST CIRCUIT

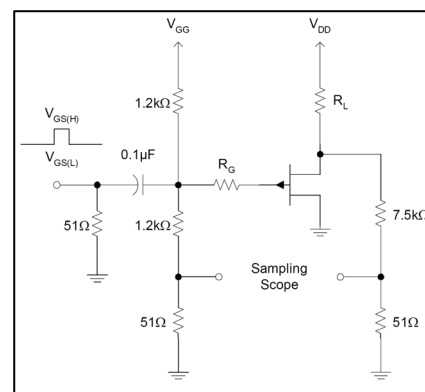

Micross Components Europe