



**HEWLETT
PACKARD**

HEXADECIMAL AND NUMERIC DISPLAYS FOR INDUSTRIAL APPLICATIONS

5082-7356
5082-7357
5082-7358
5082-7359

Features

- CERAMIC/GLASS PACKAGE
- ADDED RELIABILITY
- NUMERIC 5082-7356/-7357
 - 0-9, Test State, Minus Sign, Blank States, Decimal Point
 - 7356 Right Hand D.P., 7357 Left Hand D.P.
- HEXADECIMAL 5082-7359
 - 0-9, A-F, Base 16 Operation, Blanking Control, Conserves Power, No Decimal Point
- TTL COMPATIBLE
- INCLUDES DECODER/DRIVER WITH MEMORY
 - 8421 Positive Logic Input
- 4 x 7 DOT MATRIX ARRAY
 - Shaped Character, Excellent Readability
- STANDARD DUAL-IN-LINE PACKAGE
 - 15.2 mm x 10.2 mm (0.6 inch x 0.4 inch)
- CATEGORIZED FOR LUMINOUS INTENSITY

Description

The HP 5082-735X series solid state numeric and hexadecimal displays with on-board decoder/driver and memory provide 7.4 mm (0.29 inch) displays for use in adverse industrial environments.

The 5082-7356 numeric display decodes positive 8421 BCD logic inputs into characters 0-9 "—" sign, a test pattern, and four blanks in the invalid BCD states. The unit employs a right-hand decimal point.

Package Dimensions

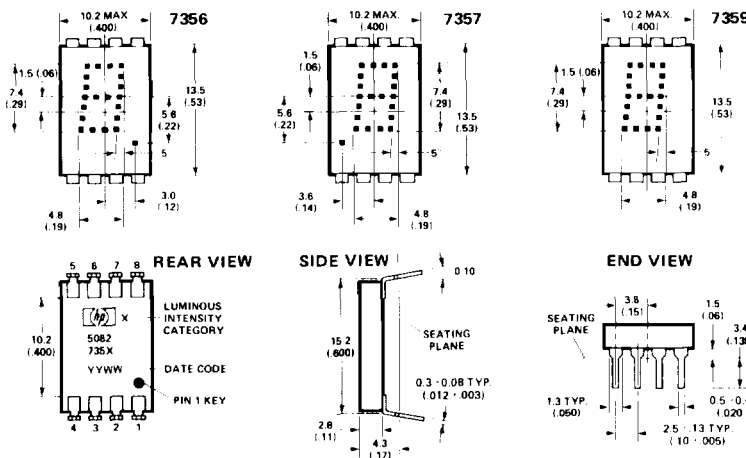

PIN	FUNCTION	
	5082-7356 AND 7357 NUMERIC	5082-7359 HEXA DECIMAL
1	Input 2	Input 2
2	Input 4	Input 4
3	Input 8	Input 8
4	Decimal point	Blanking control
5	Latch enable	Latch enable
6	Ground	Ground
7	V _{CC}	V _{CC}
8	Input 1	Input 1

- NOTES:
1. Dimensions in millimeters and (inches).
 2. Unless otherwise specified, the tolerance on all dimensions is $\pm 0.38\text{mm}$ ($\pm 0.015\text{ in.}$).
 3. Digit center line is $\pm 0.25\text{mm}$ ($\pm 0.01\text{ in.}$) from package center line.

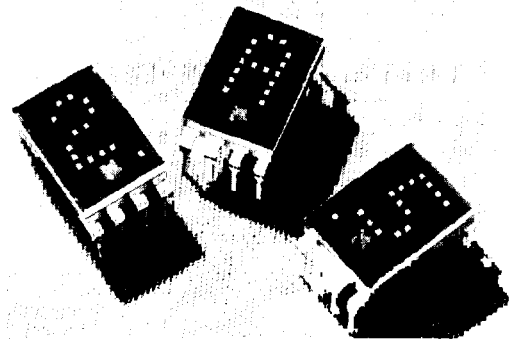

The 5082-7357 is the same as the 5082-7356, except that the decimal point is located on the left-hand side of the digit.

The 5082-7359 hexadecimal display decodes positive 8421 logic inputs into 16 states, 0-9 and A-F. In place of the decimal point an input is provided for blanking the display (all LED's off), without losing the contents of the memory. Applications include terminals and computer systems using the base-16 character set.

The 5082-7358 is a (± 1) overrange display including a right-hand decimal point.

Applications

Typical applications include control systems, instrumentation, communication systems, and transportation equipment.

ALPHANUMERIC
DISPLAYS

Absolute Maximum Ratings

Description	Symbol	Min.	Max.	Unit
Storage temperature, ambient	T_S	-65	+125	°C
Operating temperature, ambient ^{(1),(2)}	T_A	-55	+100	°C
Supply voltage ⁽³⁾	V_{CC}	-0.5	+7.0	V
Voltage applied to input logic, dp and enable pins	V_{IL}, V_{DP}, V_I	-0.5	+7.0	V
Voltage applied to blanking input ⁽⁷⁾	V_B	0.5	V_{CC}	V
Maximum solder temperature at 1.59mm (.062 inch) below seating plane; $t \leq 5$ seconds			260	°C

Recommended Operating Conditions

Description	Symbol	Min.	Nom.	Max.	Unit
Supply Voltage	V_{CC}	4.5	5.0	5.5	V
Operating temperature, ambient	T_A	-55		+85	°C
Enable Pulse Width	t_w	100			nsec
Time data must be held before positive transition of enable line	t_{STDP}	50			nsec
Time data must be held after positive transition of enable line	t_{HOLD}	50			nsec
Enable pulse rise time	t_{RII}			200	nsec

Electrical/Optical Characteristics ($T_A = -55^\circ\text{C}$ to $+85^\circ\text{C}$, Unless Otherwise Specified)

Description	Symbol	Test Conditions	Min.	Typ. ⁽⁴⁾	Max.	Unit
Supply Current	I_{CC}	$V_{CC} = 5.5\text{V}$ (characters "5" or "B" displayed)		112	170	mA
Power dissipation	P_I			560	935	mW
Luminous intensity per LED (Digit average) ^{(5),(6)}	I_v	$V_{CC} = 5.0\text{V}$, $T_A = 25^\circ\text{C}$	40	85		μcd
Logic low-level input voltage	V_{IL}	$V_{CC} = 4.5\text{V}$			0.8	V
Logic high-level input voltage	V_{IH}		2.0			V
Enable low-voltage; data being entered	V_{EIL}				0.8	V
Enable high-voltage; data not being entered	V_{EIH}		2.0			V
Blanking low-voltage; display not blanked ⁽⁷⁾	V_{BI}				0.8	V
Blanking high-voltage; display blanked ⁽⁷⁾	V_{BHI}		3.5			V
Blanking low-level input current ⁽⁷⁾	I_{BI}		$V_{CC} = -5.5\text{V}$, $V_{BI} = 0.8\text{V}$			50
Blanking high-level input current ⁽⁷⁾	I_{BHI}	$V_{CC} = 5.5\text{V}$, $V_{BHI} = 4.5\text{V}$			1.0	mA
Logic low-level input current	I_{IL}	$V_{CC} = 5.5\text{V}$, $V_{IL} = 0.4\text{V}$			-1.6	mA
Logic high-level input current	I_{IH}	$V_{CC} = 5.5\text{V}$, $V_{IH} = 2.4\text{V}$			+100	μA
Enable low-level input current	I_{EIL}	$V_{CC} = 5.5\text{V}$, $V_{EIL} = 0.4\text{V}$			-1.6	mA
Enable high-level input current	I_{EIH}	$V_{CC} = 5.5\text{V}$, $V_{EIH} = 2.4\text{V}$			+130	μA
Peak wavelength	λ_{PEAK}	$T_A = 25^\circ\text{C}$		655		nm
Dominant Wavelength ⁽⁸⁾	λ_d	$T_A = 25^\circ\text{C}$		640		nm
Weight				1.0		gm

Notes: 1. Nominal thermal resistance of a display mounted in a socket which is soldered into a printed circuit board: $\theta_{JA} = 50^\circ\text{C/W}$; $\theta_{JL} = 15^\circ\text{C/W}$. 2. θ_{JA} of a mounted display should not exceed 35°C/W for operation up to $T_A = +100^\circ\text{C}$. 3. Voltage values are with respect to device ground, pin 6. 4. All typical values at $V_{CC} = 5.0$ Volts, $T_A = 25^\circ\text{C}$. 5. These displays are categorized for luminous intensity with the intensity category designated by a letter located on the back of the display contiguous with the Hewlett-Packard logo marking. 6. The luminous intensity at a specific ambient temperature, $I_v(T_A)$, may be calculated from this relationship: $I_v(T_A) = I_{v(25^\circ\text{C})} (0.985)^{(T_A - 25^\circ\text{C})}$. 7. Applies only to 7359. 8. The dominant wavelength, λ_d , is derived from the CIE chromaticity diagram and represents the single wavelength which defines the color of the device.

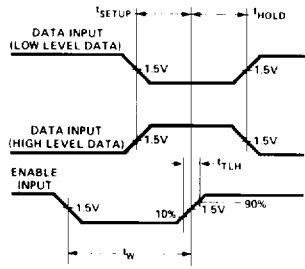

Figure 1. Timing Diagram of 5082-735X Series Logic.

BCD DATA ⁽¹⁾			TRUTH TABLE		
X ₈	X ₄	X ₂	X ₁	5082 7356/7357	5082 7359
L	L	L	L	0	0
L	L	L	H	1	1
L	L	H	L	2	2
L	L	H	H	3	3
L	H	L	L	4	4
L	H	L	H	5	5
L	H	H	L	6	6
L	H	H	H	7	7
H	L	L	L	8	8
H	L	L	H	9	9
H	L	H	L	(BLANK)	(BLANK)
H	L	H	H	(BLANK)	(BLANK)
H	H	L	L	(BLANK)	(BLANK)
H	H	L	H	(BLANK)	(BLANK)
H	H	H	L	(BLANK)	(BLANK)
H	H	H	H	(BLANK)	(BLANK)
DECIMAL PT ⁽²⁾			ON	V _{DP} - L	
			OFF	V _{DP} - H	
ENABLE ⁽¹⁾			LOAD DATA	V _L - L	
			LATCH DATA	V _L - H	
BLANKING ⁽³⁾			DISPLAY ON	V _B - L	
			DISPLAY OFF	V _B - H	

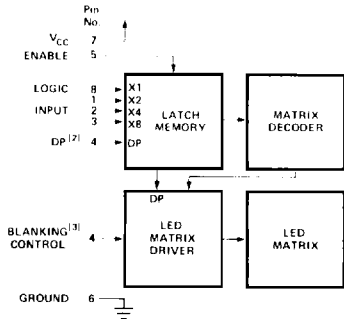

Figure 2. Block Diagram of 5082-735X Series Logic.

Notes:

- H = Logic High, L = Logic Low. With the enable input at logic high changes in BCD input logic levels or D.P. input have no effect upon display memory, displayed character, or D.P.
- The decimal point input, DP, pertains only to the 5082-7356 and 5082-7357 displays.
- The blanking control input, B, pertains only to the 5082-7359 hexadecimal display. Blanking input has no effect upon display memory.

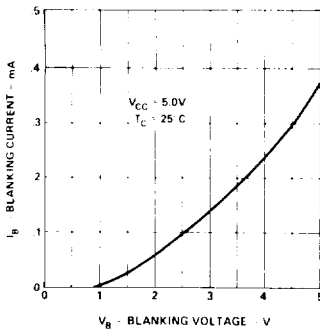

Figure 3. Typical Blanking Control Current vs. Voltage for 5082-7359.

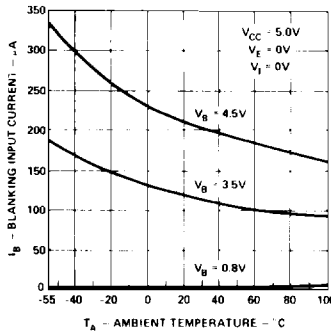

Figure 4. Typical Blanking Control Input Current vs. Ambient Temperature for 5082-7359.

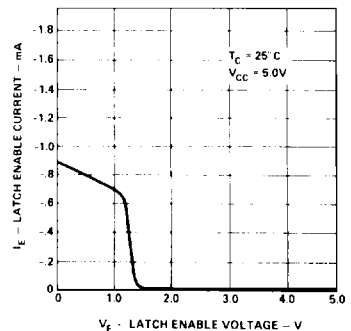

Figure 5. Typical Latch Enable Input Current vs. Voltage.

ALPHANUMERIC DISPLAYS

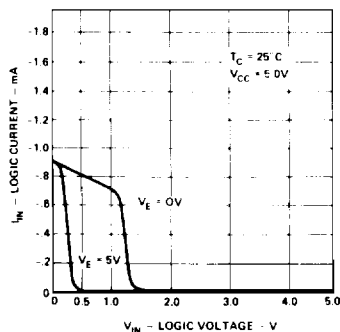

Figure 6. Typical Logic and Decimal Point Input Current vs. Voltage.

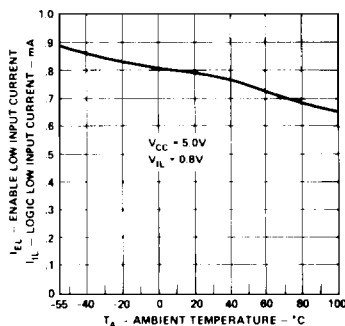

Figure 7. Typical Logic and Enable Low Input Current vs. Ambient Temperature.

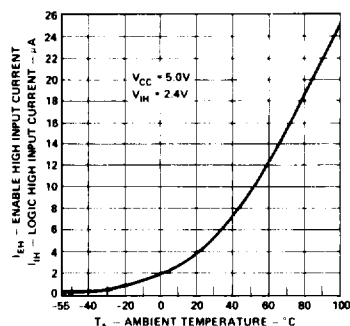

Figure 8. Typical Logic and Enable High Input Current vs. Ambient Temperature.

Operational Considerations

ELECTRICAL

The 5082-735X series devices use a modified 4 x 7 dot matrix of light emitting diodes (LED's) to display decimal/hexadecimal numeric information. The LED's are driven by constant current drivers. BCD information is accepted by the display memory when the enable line is at logic low and the data is latched when the enable is at logic high. To avoid the latching of erroneous information, the enable pulse rise time should not exceed 200 nanoseconds. Using the enable pulse width and data setup and hold times listed in the Recommended Operating Conditions allows data to be clocked into an array of displays at a 6.7MHz rate.

The blanking control input on the 5082-7395 display blanks (turns off) the displayed hexadecimal information without disturbing the contents of display memory. The display is blanked at a minimum threshold level of 3.5 volts. This may be easily achieved by using an open collector TTL gate and a pull-up resistor. For example, (1/6) 7416 hexinverter buffer/driver and a 120 ohm pull-up resistor will provide sufficient drive to blank eight displays. The size of the blanking pull-up resistor may be calculated from the following formula, where N is the number of digits:

$$R_{\text{blank}} = (V_{CC} - 3.5V) / [N (1.0mA)]$$

The decimal point input is active low true and this data is latched into the display memory in the same fashion as is the BCD data. The decimal point LED is driven by the on-board IC.

The ESD susceptibility of these IC devices is Class A of MIL-STD-883 or Class 2 of DOD-STD-1686 and DOD-HDBK-263.

MECHANICAL

These displays are designed for use in adverse industrial environments.

These displays may be mounted by soldering directly to a printed circuit board or inserted into a socket. The lead-to-lead pin spacing is 2.54mm (0.100 inch) and the lead row spacing is 15.24mm (0.600 inch). These displays may be end stacked with 2.54mm (0.100 inch) spacing between outside pins of adjacent displays. Sockets such as Augat 324-AG2D (3 digits) or Augat 508-AG8D (one digit, right angle mounting) may be used.

The primary thermal path for power dissipation is through the device leads. Therefore, to insure reliable operation up to an ambient temperature of +100°C, it is important to maintain a case-to-ambient thermal resistance of less than 35°C/watt as measured on top of display pin 3.

Post solder cleaning may be accomplished using water, Freon/alcohol mixtures formulated for vapor cleaning processing (up to 2 minutes in vapors at boiling) or Freon/alcohol mixtures formulated for room temperature cleaning. Suggested solvents: Freon TF, Freon TE, Genesolv DI-15, Genesolv DE-15.

CONTRAST ENHANCEMENT

The 5082-735X displays have been designed to provide the maximum possible ON/OFF contrast when placed behind an appropriate contrast enhancement filter. Some suggested filters are Panelgraphic Ruby Red 60 and Dark Red 63, SGL Homalite H100-1605, 3M Light Control Film and Polaroid HRCF Red Circular Polarizing Filter. For further information see Hewlett-Packard Application Note 964.

Solid State Over Range Display

For display applications requiring a \pm , 1, or decimal point designation, the 5082-7358 over range display is available. This display module comes in the same package as the 5082-735X series numeric display and is completely compatible with it.

Package Dimensions

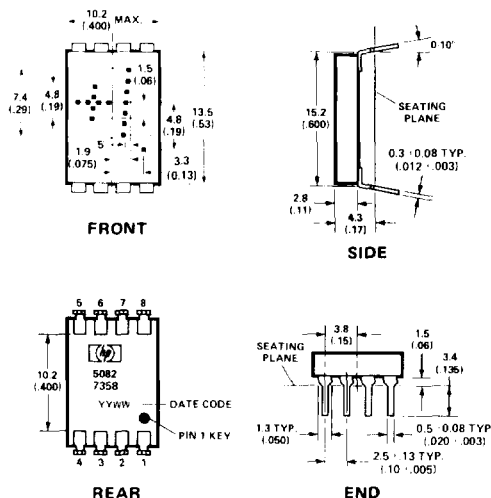

NOTES:
 1. DIMENSIONS IN MILLIMETERS AND (INCHES).
 2. UNLESS OTHERWISE SPECIFIED, THE TOLERANCE ON ALL DIMENSIONS IS ± 0.38 MM (± 0.015 INCHES).

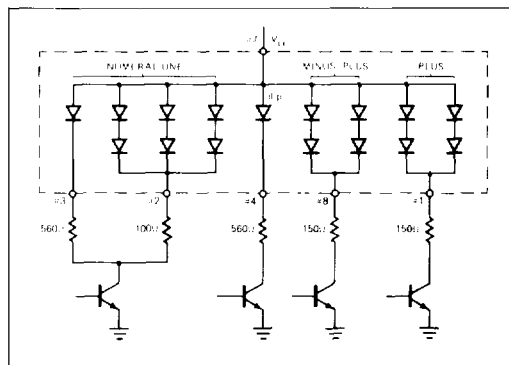

Figure 9. Typical Driving Circuit.

TRUTH TABLE

CHARACTER	PIN			
	1	2,3	4	8
+	H	X	X	H
--	L	X	X	H
1	X	H	X	X
Decimal Point	X	X	H	X
Blank	L	L	L	L

NOTES: L: Line switching transistor in Figure 9 cutoff.
 H: Line switching transistor in Figure 9 saturated.
 X: 'Don't care'

Electrical/Optical Characteristics

5082-7358 ($T_A = -55^\circ\text{C}$ to $+85^\circ\text{C}$, Unless Otherwise Specified)

DESCRIPTION	SYMBOL	TEST CONDITIONS	MIN	TYP	MAX	UNIT
Forward Voltage per LED	V_F	$I_F = 10$ mA		1.6	2.0	V
Power dissipation	P_T	$I_F = 10$ mA all diodes lit		280	320	mW
Luminous Intensity per LED (digit average)	I_L	$I_F = 6$ mA $T_C = 25^\circ\text{C}$	40	85		μcd
Peak wavelength	λ_{peak}	$T_C = 25^\circ\text{C}$		655		nm
Dominant Wavelength	λ_d	$T_C = 25^\circ\text{C}$		640		nm
Weight				1.0		gm

Recommended Operating Conditions

	SYMBOL	MIN	NOM	MAX	UNIT
LED supply voltage	V_{CC}	4.5	5.0	5.5	V
Forward current, each LED	I_F		5.0	10	mA

NOTE:
 LED current must be externally limited. Refer to Figure 9 for recommended resistor values.

Absolute Maximum Ratings

DESCRIPTION	SYMBOL	MIN.	MAX.	UNIT
Storage temperature, ambient	T_S	-65	+125	$^\circ\text{C}$
Operating temperature, ambient	T_A	-55	+100	$^\circ\text{C}$
Forward current, each LED	I_F		10	mA
Reverse voltage, each LED	V_R		4	V

ALPHANUMERIC DISPLAYS