



DATA SHEET

Preliminary

O K I O P T I C A L C O M P O N E N T S

OL3902W Planer Lightwave Circuit Module

February 2001

Oki Semiconductor

DESCRIPTION

Oki Semiconductor's OL3902W bidirectional PLC module is a high reliability hybrid-integrated Planer Lightwave Circuit Module using a plastic package. The OL3902W is designed for 1.3 μm and 1.5 μm bidirectional transmission. The PLC module consists of a spot-size converted laser diode (SSC-LD), a photo diode (PD), a monitor PD, a preamplifier, a fiber pigtail, and a PLC platform that is a silicon terrace on which the active optical devices are assembled.

FEATURES

- Hybrid-integrated planer lightwave circuit
 - spot-size converted laser diode (SSC-LD)
 - photo diode
 - monitor photo diode
 - preamplifier
 - fiber pigtail
 - PLC platform
- 1.3- μm and 1.5- μm bidirectional transmission
- Plastic package

APPLICATION

- Optical systems
- Bidirectional transmission

ABSOLUTE MAXIMUM RATINGS

Absolute Maximum Ratings

Parameter	Ratings	Unit
Operating Temperature (Ta)	-20 to 70	°C
Storage Temperature	-40 to 85	°C
Lead Soldering Temperature (10 sec)	260	°C

ELECTRICAL CHARACTERISTICS

ONU Transmitter: 155 Mbit/sec upstream direction

ONU Receiver: 155 Mbit/sec downstream direction

(Ta= -20 to 70°C, unless otherwise specified)

Electrical Characteristics

Parameter		Conditions	Min	Typ	Max	Unit
Transmitter	Bit rate			155.52		Mbps
	Fiber Output Power	Pf CW	-2		4	dBm
	Threshold Current	Ith	-		34	mA
	Center Wavelength	λ_c Pf = 3 dBm, RMS	1270		1350	nm
	Spectral Width	DI Pf = 3 dBm, RMS (σ)			5.8	nm
	LD Forward Voltage	Vop Pf = 3 dBm			1.45	V
	LD Forward Current	Iop Pf = 3 dBm			80	mA
	Rise and Fall times	tr, tf Pf = 3 dBm			1	ns
	Monitor Current	Im P = 3 dBm	100		400	μ A
	Monitor Dark Current	Id Pf = 3 dBm, Ta = 25°C			15	nA
Tracking Error	Er Im = const. @ Pf = 3 dBm (25°C)	-1		1	dB	
Receiver	Power Supply Voltage	Vcc -	3.0	3.3	3.6	V
	Responsivity	Re Pin = -21 dBm, Vcc = 3.3 V	34	40		kV / W
	Output Bias Voltage	Vb Pin = 0 mW, Vcc = 3.3 \pm 0.01 V, Tc = 25°C,	2.3	2.35	2.4	V
	Transimpedance	Zt -		96		Ω
	Rise and Fall times	tr, tf 10% - 90%		1	2	ns
Return Loss	RI λ = 1480 to 1580 nm	20			dB	

Connector and Fiber Specifications

Connector	FC-PC, SC-PC, MUJ-PC, etc.
Fiber	1.31 μm Single Mode Fiber Code Diameter : 0.9 mm Color : Yellow Bending Radius : 20 mm (min) Heat-resistant Length : Options

PACKAGE DIMENSIONS

(Units: mm)

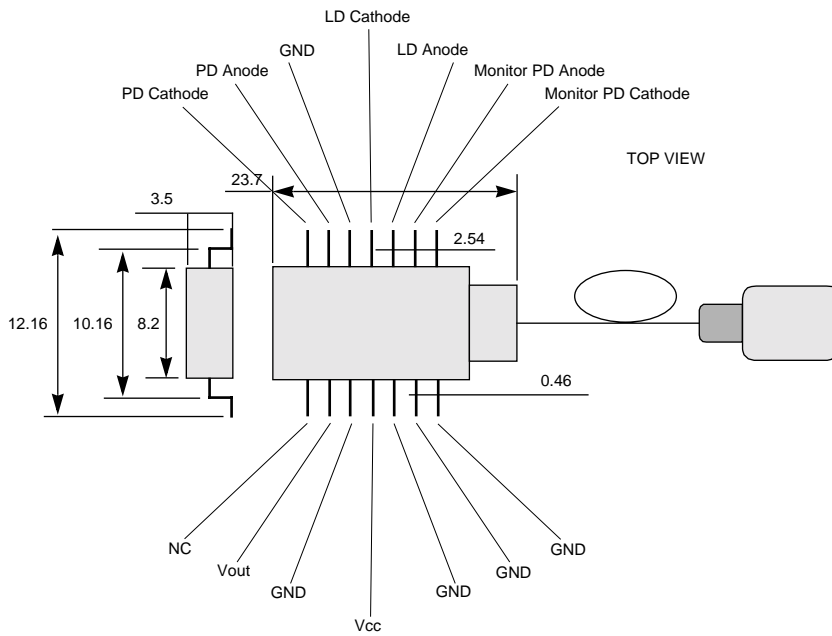



NOTES

The information contained herein can change without notice owing to product and/or technical improvements.

Please make sure before using the product that the information you are referring to is up-to-date.

The outline of action and examples of application circuits described herein have been chosen as an explanation of the standard action and performance of the product. When you actually plan to use the product, please ensure that the outside conditions are reflected in the actual circuit and assembly designs.

Okī assumes no responsibility or liability whatsoever for any failure or unusual or unexpected operation resulting from misuse, neglect, improper installation, repair, alteration or accident, improper handling, or unusual physical or electrical stress including, but not limited to, exposure to parameters outside the specified maximum ratings or operation outside the specified operating range.

Neither indemnity against nor license of a third party's industrial and intellectual property right, etc. is granted by us in connection with the use of product and/or the information and drawings contained herein. No responsibility is assumed by us for any infringement of a third party's right which may result from the use thereof.

When designing your product, please use our product below the specified maximum ratings and within the specified operating ranges, including but not limited to operating voltage, power dissipation, and operating temperature.

The products listed in this document are intended for use in general electronics equipment for commercial applications (e.g., office automation, communication equipment, measurement equipment, consumer electronics, etc.). These products are not authorized for use in any system or application that requires special or enhanced quality and reliability characteristics nor in any system or application where the failure of such system or application may result in the loss or damage of property or death or injury to humans. Such applications include, but are not limited to: traffic control, automotive, safety, aerospace, nuclear power control, and medical, including life support and maintenance.

Certain parts in this document may need governmental approval before they can be exported to certain countries. The purchaser assumes the responsibility of determining the legality of export of these parts and will take appropriate and necessary steps, at their own expense, for export to another country.

Copyright 2001 Okī Semiconductor

Okī Semiconductor reserves the right to make changes in specifications at anytime and without notice. This information furnished by Okī Semiconductor in this publication is believed to be accurate and reliable. However, no responsibility is assumed by Okī Semiconductor for its use; nor for any infringements of patents or other rights of third parties resulting from its use. No license is granted under any patents or patent rights of Okī.



Oki REGIONAL SALES OFFICES

Optical Components

Northwest Area

785 N. Mary Avenue
Sunnyvale, CA 94086
Tel: 408/720-1900
Fax: 408/737-6579

Southeast Area

1590 Adamson Parkway
Suite 220
Morrow, GA 30260
Tel: 770/960-9660
Fax: 770/960-9682

Eastern Area

411 Hackensack Avenue
Hackensack, NJ 07601
Tel: 201/406-4061, 201/646-0011 (ext 102)
Fax: 201/646-9061

Oki Web Site:

<http://www.okisemi.com>

For Oki Literature:

Call toll free 1-800-OKI-6388
(6 a.m. to 5 p.m. Pacific Time)

Oki Stock No: 320247-000

Oki Semiconductor

Corporate Headquarters

785 N. Mary Avenue
Sunnyvale, CA 94085-2909
Tel: 408/720-1900
Fax: 408/720-1918