

**FEATURES**

- CDMA/EVDO and WCDMA/HSPA Compliant
- High Efficiency (R99 waveform):
  - 46% @ P<sub>OUT</sub> = +28.6 dBm
- Optimized for SMPS Supply
- Low Leakage Current in Shutdown Mode: <5  $\mu$ A
- Internal Voltage Regulator
- Optimized for a 50  $\Omega$  System
- Internal DC blocks on IN/OUT RF ports
- 1.8 V Control Logic
- RoHS Compliant Package, 260  $^{\circ}$ C MSL-3

**APPLICATIONS**

- Wireless Handsets and Data Devices for:
  - WCDMA/HSPA IMT-Band
  - CDMA/EVDO Bandclass 0

**PRODUCT DESCRIPTION**

The AWT5005 PA is designed to provide highly linear output for WCDMA and CDMA handsets and data devices with high efficiency at high power mode. This ANADIGICS PA can be used with an external switch mode power supply (SMPS) to improve its efficiency and reduce current consumption further at high, medium and low output powers. The device is manufactured on an advanced InGaP HBT MMIC technology offering state-of-the-art reliability, temperature stability, and ruggedness. There are three selectable bias modes that optimize efficiency for different output power levels, and a shutdown mode with low leakage current, which increases handset talk and standby time. The self-contained 3 mm x 3 mm x 0.9 mm surface mount package incorporates matching networks optimized for output power, efficiency, and linearity in a 50  $\Omega$  system.

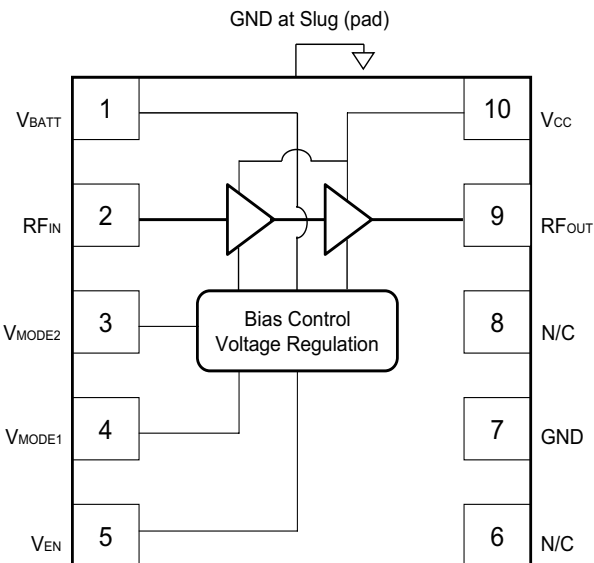
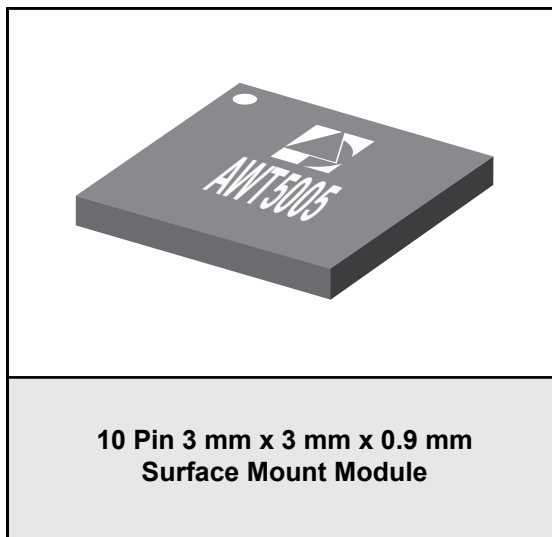

**Figure 1: Block Diagram**

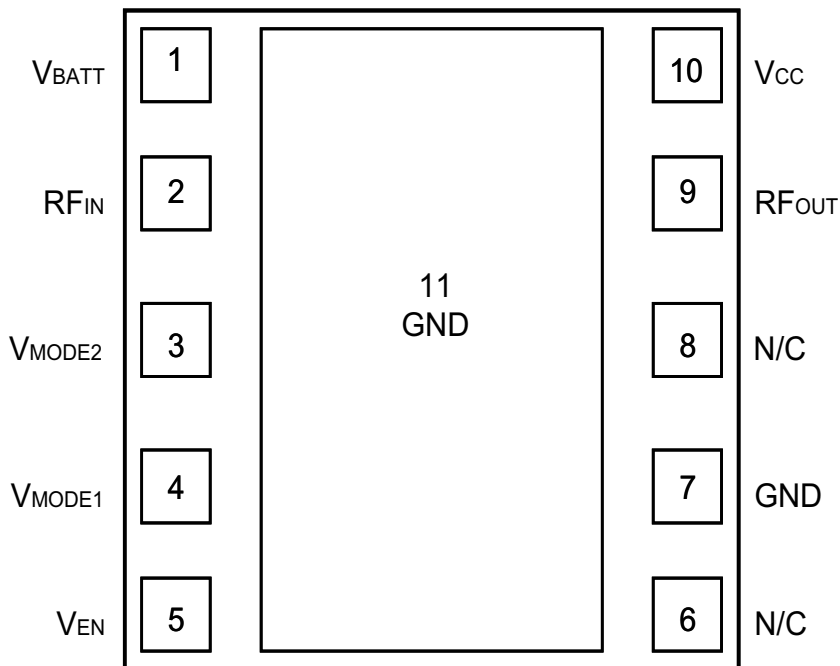

Figure 2: Pinout (X-ray Top View)

Table 1: Pin Description

PIN	NAME	DESCRIPTION
1	$V_{BATT}$	Battery Voltage
2	$RF_{IN}$	RF Input
3	$V_{MODE2}$	Mode Control Voltage 2
4	$V_{MODE1}$	Mode Control Voltage 1
5	$V_{EN}$	PA Enable Voltage
6	N/C	No Connection
7	GND	Ground
8	N/C	No Connection
9	$RF_{OUT}$	RF Output
10	$V_{CC}$	Supply Voltage
11	GND	Ground

**ELECTRICAL CHARACTERISTICS**

**Table 2: Absolute Minimum and Maximum Ratings**

PARAMETER	MIN	TYP	MAX	UNIT
RF Input (P <sub>IN</sub> )	-	0	10	dBm
V <sub>CC</sub>	-1.2	3.4	5	V
V <sub>BATT</sub>	-1.2	3.4	6	V
Control Voltage (V <sub>ENABLE</sub> , V <sub>MODE</sub> )	0	-	3.5	V
Storage Temperature (T <sub>STORAGE</sub> )	-40	25	150	°C

Functional operation to the specified performance is not implied under these conditions. Operation of any single parameter in excess of the absolute ratings may cause permanent damage. No damage occurs if one parameter is set at the limit while all other parameters are set within normal operating ranges.

**Table 3: Operating Ranges**

PARAMETER	MIN	TYP	MAX	UNIT	COMMENTS
Operating Frequency (f)	824	-	849	MHZ	UMTS Band 5, CDMA BC 0
Supply Voltage (V <sub>CC</sub> )	+0.6	+3.4	+4.4	V	P <sub>OUT</sub> ≤ +28.6 dBm
Battery Voltage (V <sub>BATT</sub> )	+3.1	+3.4	+4.4	V	P <sub>OUT</sub> ≤ +28.6 dBm
Enable Voltage (V <sub>ENABLE</sub> )	+1.35 0	+1.8 0	+3.1 +0.5	V	PA “on” PA “shut down”
Mode Control Voltage (V <sub>MODE1</sub> )	+1.35 0	+1.8 0	+3.1 +0.5	V	Low Bias Mode High Bias Mode
RF Output Power (P <sub>OUT</sub> ) <sup>(1)</sup> R99 WCDMA, HPM HSPA (MPR = 0), HPM R99 WCDMA, MPM HSPA (MPR = 0), MPM R99 WCDMA, LPM HSPA (MPR = 0), LPM	27.8 26.7 - - - -	28.6 27.5 17 16 8 7	- - - - - -	dBm	3GPP TS 34.121-1, Rel 8 Table C.11.1.3, for WCDMA Subtest 1
CDMA Output Power <sup>(1)</sup> HPM MPM LPM	26.7 - -	27.5 16 7	- - -	dBm	CDMA2000, RC-1
Case Temperature (T <sub>c</sub> )	-30	-	+90	°C	

The device may be operated safely over these conditions; however, parametric performance is guaranteed only over the conditions defined in the electrical specifications.

Notes:

(1) For operation at V<sub>CC</sub> = +3.1 V, P<sub>OUT</sub> is derated by 0.8 dB.

**Table 4: Electrical Specifications - WCDMA Operation (R99 waveform)**  
**(T<sub>C</sub> = +25 °C, V<sub>BATT</sub> = +3.4 V, V<sub>EN</sub> = +1.8 V, 50 Ω system, unless otherwise specified)**

PARAMETER	MIN	TYP	MAX	UNIT	COMMENTS			
					P <sub>OUT</sub>	V <sub>CC</sub>	V <sub>MODE1</sub>	V <sub>MODE2</sub>
Gain	26 18 14	29 21.5 17	32 25 20	dB	+28.6 dBm +17 dBm +8 dBm	3.4 V 1.4 V 0.7 V	0 V 1.8 V 1.8 V	0 V 0 V 1.8 V
ACLR1 at 5 MHz offset <sup>(1)</sup>	- - -	-40 -41 -42	-36 -36 -36	dBc	+28.6 dBm +17 dBm +8 dBm	3.4 V 1.4 V 0.7 V	0 V 1.8 V 1.8 V	0 V 0 V 1.8 V
ACLR2 at 10 MHz offset <sup>(1)</sup>	- - -	-56 -55 -57	-48 -48 -48	dBc	+28.6 dBm +17 dBm +8 dBm	3.4 V 1.4 V 0.7 V	0 V 1.8 V 1.8 V	0 V 0 V 1.8 V
Efficiency <sup>(1)</sup>	- - -	46 25 14	- - -	%	+28.6 dBm +17 dBm +8 dBm	3.4 V 1.4 V 0.7 V	0 V 1.8 V 1.8 V	0 V 0 V 1.8 V
Quiescent Current (I <sub>cq</sub> ) Low Bias Mode	-	24	-	mA	through V <sub>CC</sub> pin, V <sub>MODE1,2</sub> = +1.8 V			
Mode Control Current	-	<0.1	0.1	mA	through V <sub>MODE</sub> pin, V <sub>MODE1,2</sub> = 1.8 V			
Enable Current	-	0.05	0.1	mA	through V <sub>ENABLE</sub> pin			
BATT Current	-	3.5	-	mA	through V <sub>BATT</sub> pin, V <sub>MODE1,2</sub> = +1.8 V			
Leakage Current	-	<5	10	μA	V <sub>BATT</sub> = +4.4 V, V <sub>CC</sub> = +4.4 V V <sub>ENABLE</sub> = 0 V, V <sub>MODE1,2</sub> = 0 V			
Noise in Receive Band <sup>(2)</sup>	-	-134	-	dBm/Hz	P <sub>OUT</sub> < +28.6 dBm			
Harmonics 2f <sub>o</sub> 3f <sub>o</sub> , 4f <sub>o</sub>	- - -	-40 -45	- -	dBc	P <sub>OUT</sub> < +28.6 dBm			
Input Impedance	-	-	2:1	VSWR				
Spurious Output Level (all spurious outputs)	-	-	-70	dBc	P <sub>OUT</sub> ≤ +28.6 dBm In-band load VSWR < 5:1 Out-of-band load VSWR < 10:1 Applies over all operating conditions			
Load mismatch stress with no permanent degradation or failure	8:1	-	-	VSWR	Applies over full operating range			

## Notes:

(1) ACLR and Efficiency measured at 836.5 MHz.

(2) Noise measured at 869 MHz to 894 MHz.

**Table 5: Electrical Specifications - CDMA Operation (CDMA2000, RC-1)**  
 (T<sub>C</sub> = +25 °C, V<sub>BATT</sub> = +3.4 V, V<sub>EN</sub> = +1.8 V, 50 Ω system, unless otherwise specified)

PARAMETER	MIN	TYP	MAX	UNIT	COMMENTS			
					P <sub>OUT</sub>	V <sub>CC</sub>	V <sub>MODE1</sub>	V <sub>MODE2</sub>
Gain	26	29	32	dB	+27.5 dBm	3.4 V	0 V	0 V
	18	21.5	25		+16 dBm	1.4 V	1.8 V	0 V
	14	17	20		+7 dBm	0.7 V	1.8 V	1.8 V
Adjacent Channel Power <sup>(1)</sup> at +/- 885 kHz offset Primary Channel BW = 1.23 MHz Adjacent Channel BW = 30 kHz	-	-50	-46	dBc	+27.5 dBm	3.4 V	0 V	0 V
	-	-52	-46		+16 dBm	1.4 V	1.8 V	0 V
	-	-52	-46		+7 dBm	0.7 V	1.8 V	1.8 V
Adjacent Channel Power <sup>(1)</sup> at +/- 1.98 MHz offset Primary Channel BW = 1.23 MHz Adjacent Channel BW = 30 kHz	-	-61	-56	dBc	+27.5 dBm	3.4 V	0 V	0 V
	-	-63	-56		+16 dBm	1.4 V	1.8 V	0 V
	-	-63	-56		+7 dBm	0.7 V	1.8 V	1.8 V
Efficiency <sup>(1)</sup>	-	42	-	%	+27.5 dBm	3.4 V	0 V	0 V
	-	23	-		+16 dBm	1.4 V	1.8 V	0 V
	-	13	-		+7 dBm	0.7 V	1.8 V	1.8 V

Notes:

(1) ACLR and Efficiency measured at 836.5 MHz.

**APPLICATION INFORMATION**

To ensure proper performance, refer to all related Application Notes on the ANADIGICS web site: <http://www.anadigics.com>

**Shutdown Mode**

The power amplifier may be placed in a shutdown mode by applying logic low levels (see Operating Ranges table) to the  $V_{ENABLE}$  and  $V_{MODE1,2}$  voltages.

**Bias Modes**

The power amplifier may be placed in either a Low, Medium or High Bias mode by applying the appropriate

logic level (see Operating Ranges table) to  $V_{MODE1,2}$  voltages. The Bias Control table lists the recommended modes of operation for various applications.

Three operating modes are available to optimize current consumption. High Bias/High Power operating mode is for  $P_{OUT}$  levels  $\geq 16$  dBm. At around 17 dBm output power, the PA should be "Mode Switched" to Medium power mode. For  $P_{OUT}$  levels  $\leq \sim 7$  dBm, the PA could be switched to Low power mode for extremely low current consumption.

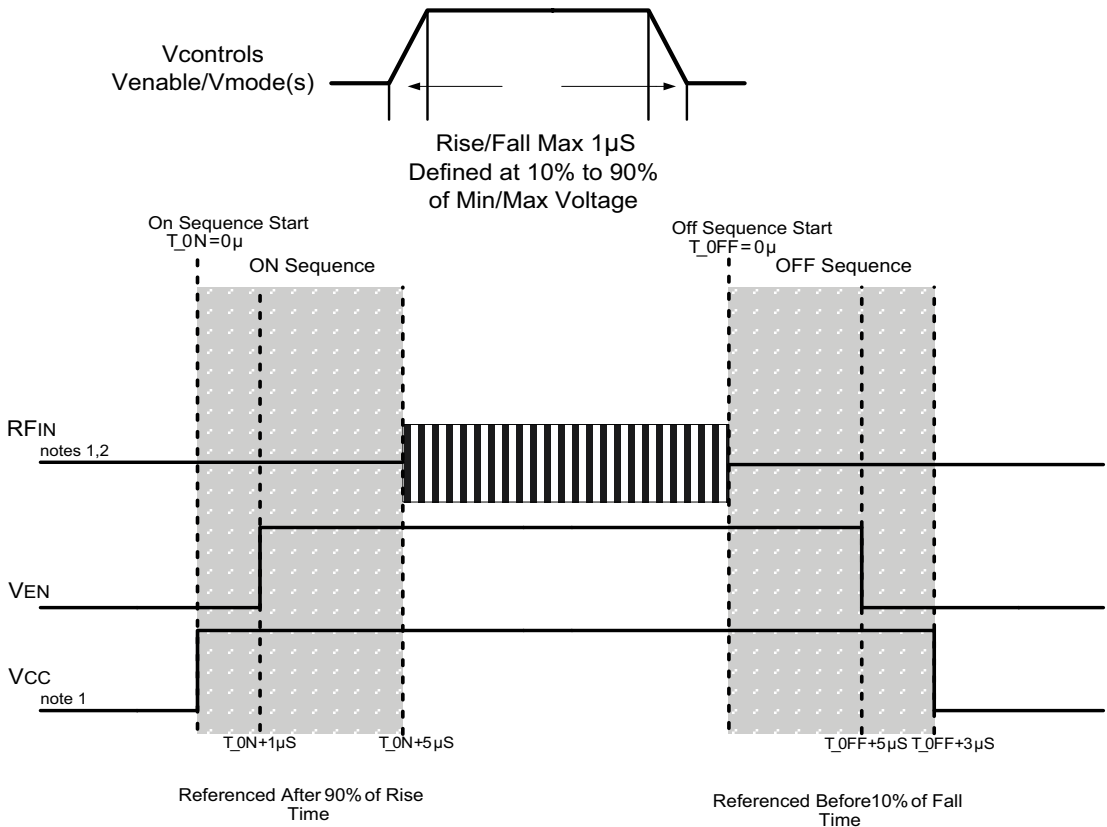

**Figure 3: Recommended ON/OFF Timing Sequence**

*Notes:*

- (1) Level might be changed after RF is ON.
- (2) RF OFF defined as  $P_{IN} \leq -30$  dBm.
- (3) Switching simultaneously between  $V_{MODE}$  and  $V_{EN}$  is not recommended.

Table 6: Bias Control

APPLICATION	P <sub>OUT</sub> LEVELS	BIAS MODE	V <sub>ENABLE</sub>	V <sub>MODE1</sub>	V <sub>MODE2</sub>	V <sub>CC</sub>	V <sub>BATT</sub>
High power (High Bias Mode)	> +16 dBm	High	+1.8 V	0 V	0 V	0.6 - 4.4 V	3.1 - 4.4 V
Med power (Med Bias Mode)	≤ +17 dBm	Medium	+1.8 V	+1.8 V	0 V	0.6 - 4.4 V	3.1 - 4.4 V
Low power (Low Bias Mode)	≤ +8 dBm	Low	+1.8 V	+1.8 V	+1.8 V	0.6 - 4.4 V	3.1 - 4.4 V
Shutdown	-	Shutdown	0 V	0 V	0 V	0.6 - 4.4 V	3.1 - 4.4 V

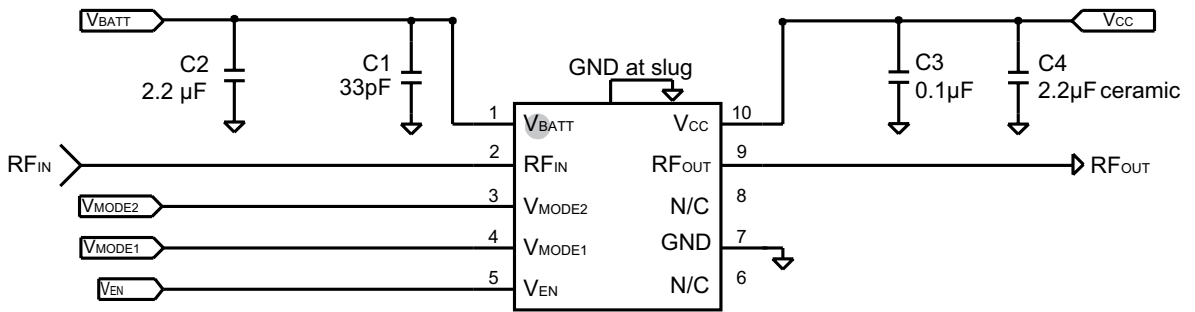
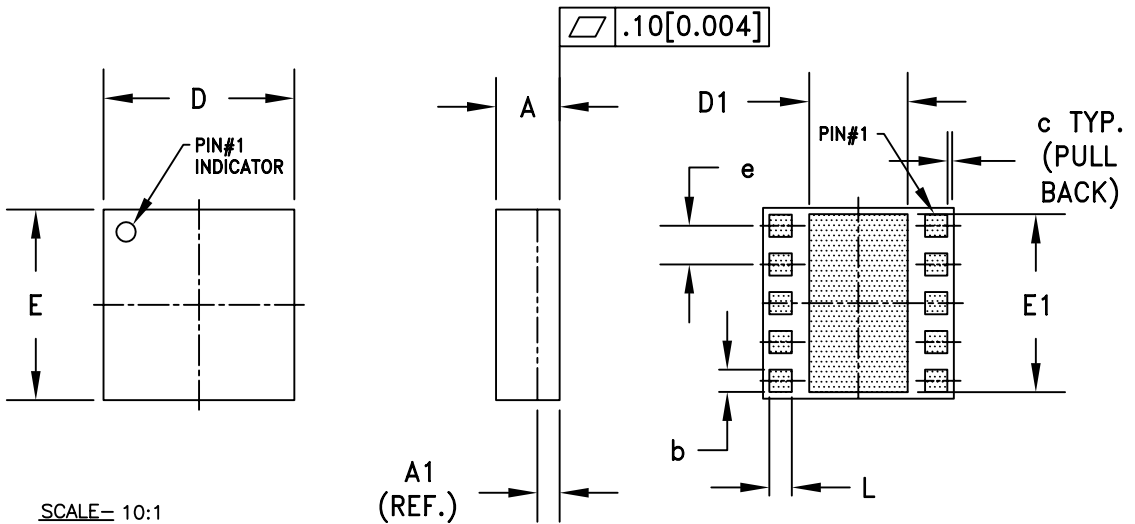

Figure 4: Evaluation Board Schematic

PACKAGE OUTLINE



SCALE= 10:1

SYMBOL	MILLIMETERS			INCHES			NOTE
	MIN.	NOM.	MAX.	MIN.	NOM.	MAX.	
A	0.88	0.94	1.00	0.035	0.037	0.039	-
A1	PLEASE REFER TO LAMINATE CONTROL DRAWING						-
b	0.32	0.35	0.40	0.013	0.014	0.016	3
c	-	0.10	-	-	0.004	-	-
D	2.88	3.00	3.12	0.113	0.118	0.123	-
D1	1.45	1.50	1.57	0.057	0.059	0.062	3
E	2.88	3.00	3.12	0.113	0.118	0.123	-
E1	2.70	2.75	2.85	0.106	0.108	0.112	3
e	0.60			0.024			3
L	0.32	0.35	0.40	0.013	0.014	0.016	3

NOTES:

1. CONTROLLING DIMENSIONS IN MILLIMETERS.
2. UNLESS SPECIFIED, TOLERANCE=±0.076[0.003].
3. SIGNAL PADS SHOWN UNIFORM SIZE FOR REFERENCE ONLY. ACTUAL SIZE AND LOCATION WILL VARY WITHIN MIN. AND MAX. DIMENSIONS ACCORDING TO THE PRODUCT DESIGN.
4. GROUND PADS SHOWN UNIFORM SIZE FOR REFERENCE ONLY. ACTUAL SIZE AND LOCATION ARE REFERENCE ONLY.
5. PITCH MEASUREMENTS (e) TAKE CENTERLINE TO CENTERLINE OF SOLDERMASK OPENINGS.
6. UNLESS SPECIFIED DIMENSIONS ARE SYMMETRICAL ABOUT CENTER LINES SHOWN.
7. LAMINATE CONTROL DRAWING SPECIFIED BY PRODUCT DESIGN.

Figure 5: Package Outline - 10 Pin 3 mm x 3 mm x 0.94 mm Surface Mount Module

TOP BRAND

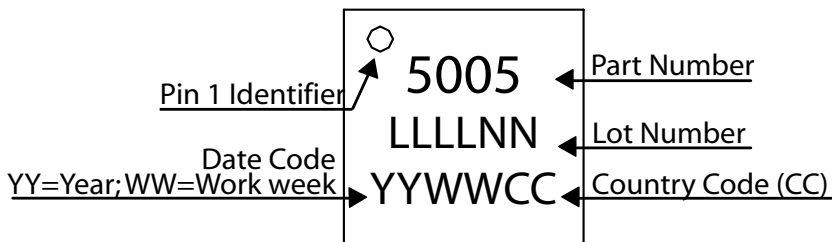
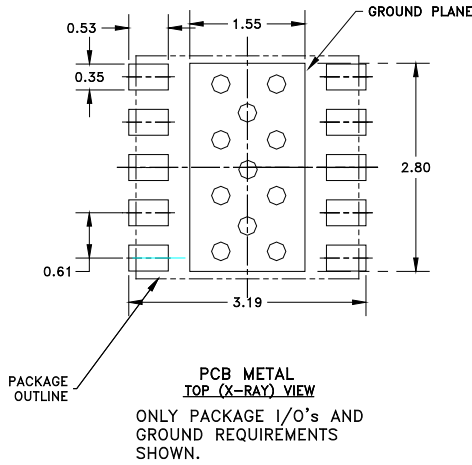

Figure 6: Branding Specification

PCB AND STENCIL DESIGN GUIDELINE



NOTES:

- (1) OUTLINE DRAWING REFERENCE: P8002478\_E
- (2) UNLESS SPECIFIED DIMENSIONS ARE SYMMETRICAL ABOUT CENTER LINES SHOWN.
- (3) DIMENSIONS IN MILLIMETERS.
- (4) VIAS SHOWN IN PCB METAL VIEW ARE FOR REFERENCE ONLY. NUMBER & SIZE OF THERMAL VIAS REQUIRED DEPENDENT ON HEAT DISSIPATION REQUIREMENT AND THE PCB PROCESS CAPABILITY.
- (5) RECOMMENDED STENCIL THICKNESS: APPROX. 0.150mm (6 Mils)

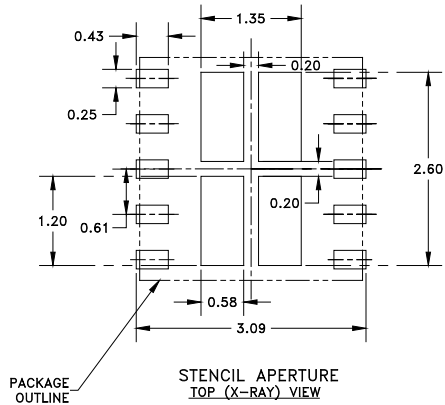
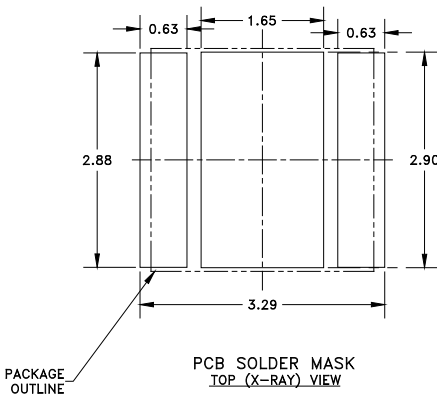
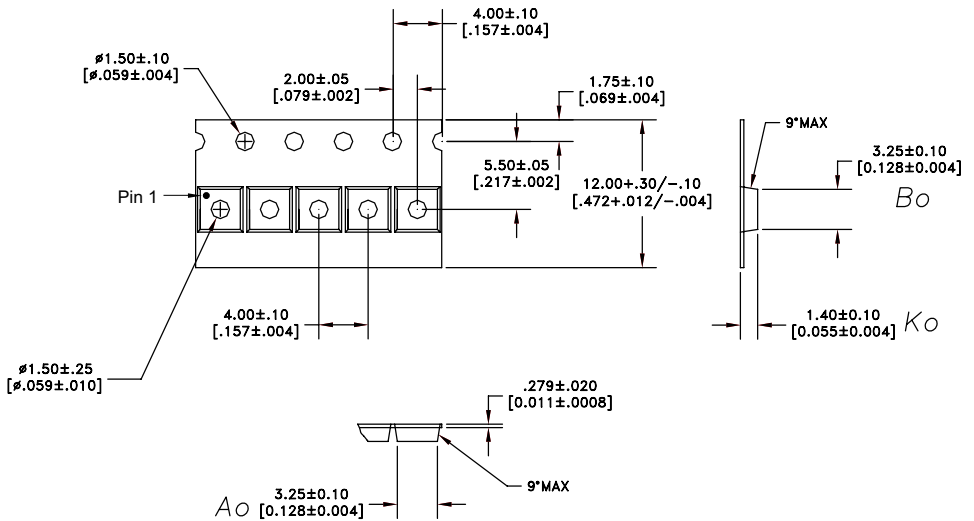

Figure 7: Recommended PCB Layout Information

COMPONENT PACKAGING



NOTES:

- 1. MATERIAL: 3000 (CARBON FILLED POLYCARBONATE)  
100% RECYCLABLE.

DIMENSIONS ARE IN MILLIMETERS [INCHES]

DIMENSIONING AND TOLERANCING PER ASME Y14.5M-1994

Figure 8: Carrier Tape

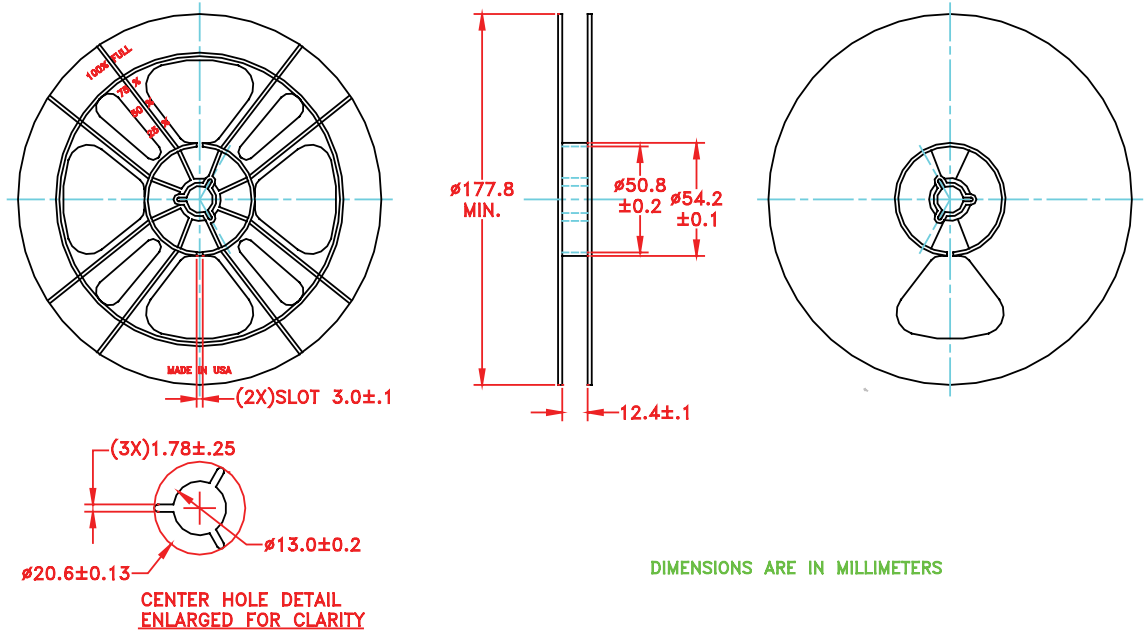

DIMENSIONS ARE IN MILLIMETERS

NOTES:

- 1. MATERIAL: BLACK CARBON POLYSTYRENE
- SURFACE RESISTIVITY: 1X10<sup>4</sup> TO 1X10<sup>8</sup> ohms/square

DIMENSIONING AND TOLERANCING PER ASME Y14.5M-1994

Figure 9: Reel

**ORDERING INFORMATION**

ORDER NUMBER	TEMPERATURE RANGE	PACKAGE DESCRIPTION	COMPONENT PACKAGING
AWT5005Q7	-30 °C to +90 °C	RoHS Compliant 10 Pin 3 mm x 3 mm x 0.9 mm Surface Mount Module	Tape and Reel, 2500 pieces per Reel
AWT5005P9	-30 °C to +90 °C	RoHS Compliant 10 Pin 3 mm x 3 mm x 0.9 mm Surface Mount Module	Partial Tape and Reel



**ANADIGICS, Inc.**  
 141 Mount Bethel Road  
 Warren, New Jersey 07059, U.S.A.  
 Tel: +1 (908) 668-5000  
 Fax: +1 (908) 668-5132

URL: <http://www.anadigics.com>

**IMPORTANT NOTICE**

ANADIGICS, Inc. reserves the right to make changes to its products or to discontinue any product at any time without notice. The product specifications contained in Advanced Product Information sheets and Preliminary Data Sheets are subject to change prior to a product's formal introduction. Information in Data Sheets have been carefully checked and are assumed to be reliable; however, ANADIGICS assumes no responsibilities for inaccuracies. ANADIGICS strongly urges customers to verify that the information they are using is current before placing orders.

**WARNING**

ANADIGICS products are not intended for use in life support appliances, devices or systems. Use of an ANADIGICS product in any such application without written consent is prohibited.