

DESCRIPTION

The 8266/8267 2-Input, 4-Bit Digital Multiplexer is a monolithic array utilizing familiar TTL circuit structures. The 8267 features a bare-collector output to allow expansion with other devices.

The multiplexer is intended for use at the inputs to adders, registers and in other parallel data handling applications.

The multiplexer is able to choose from two different input sources, each containing 4

bits: A = (A₀, A₁, A₂, A₃), B = (B₀, B₁, B₂, B₃). The selection is controlled by the input S₀, while the second control input, S₁, is held at zero.

For conditional complementing, the two inputs (A_n, B_n) are tied together to form the function TRUE/COMPLEMENT, which is needed in conjunction with added elements to perform ADDITION/SUBTRACTION. Further, the inhibit state S₀ = S₁ = 1 can be used to facilitate transfer operations in an arithmetic section.

PIN CONFIGURATION

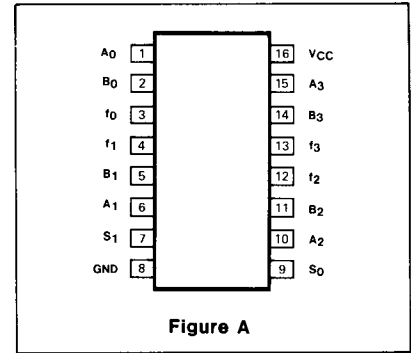

Figure A

ORDERING CODE (See Section 9 for further Package and Ordering Information)

PACKAGES	PIN CONF.	COMMERCIAL RANGES		MILITARY RANGES	
		V _{CC} =5V ± 5%; T _A =0°C to +75°C		V _{CC} = 5V ± 5%; T _A =-55°C to +125°C	
Plastic DIP	Fig.A	N8266N	• N8267N		
		N82S66N	• N82S67N		
Ceramic DIP	Fig. A	N8266F	• N8267F	S8266F	• S8267F
		N82S66F	• N82S67F		
Flatpak	Fig. A			S8266W	• S8267W

TRUTH TABLE

SELECT LINES		OUTPUTS
S ₀	S ₁	f _n (0, 1, 2, 3)
L	L	B _n
L	H	\overline{B}_n
H	L	A _n
H	H	\overline{A}_n

LOGIC DIAGRAM

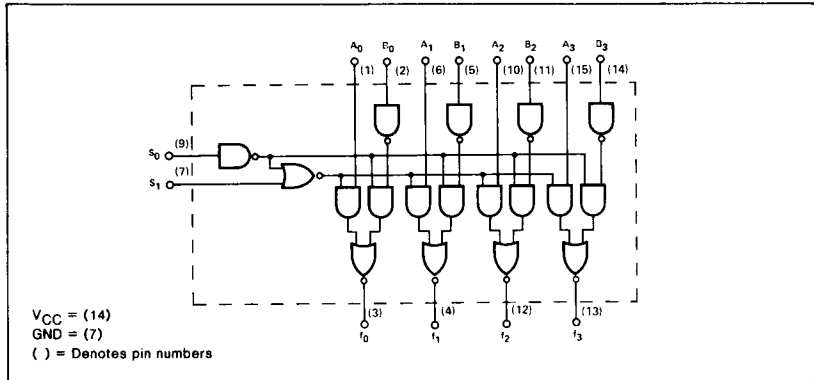

DC CHARACTERISTICS OVER OPERATING TEMPERATURE RANGE

PARAMETER	TEST CONDITIONS	82S66		82S67		UNIT
		Min	Max	Min	Max	
V _{OH} Output HIGH voltage	V _{CC} = 4.75V, I _{OH} = -800 μ A (82S66)	2.6				V
V _{OL} Output LOW voltage	V _{CC} = 4.75V, I _{OL} = 16mA		0.4		0.4	V
I _{OH} Output HIGH current	V _{CC} = 5.25V, V _{OUT} = 5.25V				250	μ A
I _{IH} Input HIGH current	V _{CC} = MAX, V _{IN} = 4.5V		40		40	μ A
I _{IL} Input LOW current	V _{CC} = MAX, V _{IN} = 0.4V		-1.6		-1.6	mA
V _{BD} Voltage breakdown	V _{CC} = 4.75V, I _{IN} = 10mA		5.5		5.5	V
I _{OS} Output short circuit current	V _{CC} = 5.25V, V _{OUT} = 0V	-20	-70			mA
I _{CC} Supply current	V _{CC} = 5.0V		52.4		52.4	mA

DC CHARACTERISTICS OVER OPERATING TEMPERATURE RANGE (b)

PARAMETER	TEST CONDITIONS	8266		8267		UNIT
		Min	Max	Min	Max	
V _{OH} Output HIGH voltage	V _{CC} = 4.75V, I _{OH} = -1mA (82S66)	2.7				V
V _{OL} Output LOW voltage	V _{CC} = 4.75V, I _{OL} = 20mA		0.5		0.5	V
I _{OH} Output HIGH current	V _{CC} = 5.25V, V _{OUT} = 5.25V				25	μ A
I _{IH} Input HIGH current	V _{CC} = MAX, V _{IN} = 4.5V		10		10	μ A
I _{IL} Input LOW current	V _{CC} = MAX, V _{IN} = 0.4V		-400		-400	μ A
I _{OS} Output short circuit current	V _{CC} = 5V, V _{OUT} = 0V	-40	-100			mA
I _{CC} Supply current	V _{CC} = 5.25V		69		69	mA

AC CHARACTERISTICS: T_A 25°C (See Section 4 for Waveforms and Conditions)

PARAMETER	TEST CONDITIONS	8266		8267		82S66		82S67		UNITS
		$C_L = 30\text{pF}$ $R_1 = \infty\Omega$ $R_2 = 84.5\Omega$		$C_L = 30\text{pF}$ $R_1 = 330\Omega$ $R_2 = 470\Omega$		$C_L = 15\text{pF}$ $R_L = 280\Omega$		$C_L = 15\text{pF}$ $R_L = 280\Omega$		
		Min	Max	Min	Max	Min	Max	Min	Max	
t _{PLH} t _{PHL}	Propagation delay S ₀ to f _n (short path)		28 28		28 28		18 18		20 20	ns ns
t _{PLH} t _{PHL}	Propagation delay S ₀ to f _n (long path)		30 30		36 36		18 18		20 20	ns ns
t _{PLH} t _{PHL}	Propagation delay A _n to f _n		20 20		20 20		10 10		12 12	ns ns
t _{PLH} t _{PHL}	Propagation delay S ₁ to f _n		25 25		28 28		15 15		18 18	ns ns
t _{PLH} t _{PHL}	Propagation delay B _n to f _n		25 25		28 28		12 12		15 15	ns ns

AC WAVEFORMS

