

Helping Customers Innovate, Improve & Grow



### Features

- 9X14 J Leaded Surface Mount Package
- Reflow Process Compatible
- AC MOS, TTL, LVPECL and LVDS
- MIL-PRF-55310 Class B Screening (optional)
- Frequency Range: 1 MHZ to 800 MHZ
- Previous Model: C1300

### Applications

- Military Systems
- Avionics and Instrumentation
- Test Equipment
- Medical Equipment

## Performance Specifications

Parameter	Min	Typ	Max	Units	Condition
<b>Frequency Stabilities<sup>1</sup></b>					
vs. operating temperature range (referenced to +25°C)	-15		+15	ppm	0... +70°C
	-25		+25	ppm	0... +70°C
	-50		+50	ppm	0... +70°C
	-100		+100	ppm	0... +70°C
	-25		+25	ppm	-40... +85°C
	-50		+50	ppm	-40... +85°C
	-100		+100	ppm	-40... +85°C
	-50		+50	ppm	-55... +125°C
Initial tolerance	-15		+15	ppm	@+25°C
	-25		+25	ppm	@+25°C
	-50		+50	ppm	@+25°C
	-100		+100	ppm	@+25°C
Overall tolerance  (Referenced to +25°C)  (includes operating temperature and initial accuracy)	-20		+20	ppm	0... +70°C
	-25		+25	ppm	0... +70°C
	-50		+50	ppm	0... +70°C
	-100		+100	ppm	0... +70°C
	-25		+25	ppm	-40... +85°C
	-50		+50	ppm	-40... +85°C
	-100		+100	ppm	-40... +85°C
	-65		+65	ppm	-55... +125°C
-100		+100	ppm	-55... +125°C	

## Performance Specifications

Parameter	Min	Typ	Max	Units	Condition
vs. supply voltage change	-2		+2	ppm	VS ± 5% Load ± 5% after 30 days of operation
vs. load change	-1		+1	ppm	
vs. aging / 1 year	-3		+3	ppm	
vs. aging / year (following years)	-1		+1	ppm	
Supply Voltage (Vs)					
Supply voltage	4.75	5.0	5.25	VDC	
Supply voltage	3.135	3.3	3.465	VDC	
Supply voltage	2.375	2.5	2.625	VDC	
Current consumption (+5 VDC)			15 20 40	mA mA mA	ACMOS or TTL 1.0 to 23.9 MHz ACMOS or TTL 24 to 49.9 MHz ACMOS or TTL 50 to 125.00 MHz
Current consumption (+3.3 VDC or +2.5 VDC)			6 8 12 40 75 100	mA mA mA mA mA mA	ACMOS 1.0 to 14.9 MHz ACMOS 15.0 to 39.9 MHz ACMOS 40.0 to 59.9 MHz ACMOS 60.0 to 125.0 MHz LVPECL or LVDS No load <200 MHz LVPECL or LVDS No load >200 MHz
RF Output					
Signal	ACMOS				
Load		15	50	pF	
Signal Level (Vol)			0.5 .3 .25	VDC VDC VDC	with Vs=5.0V and 15pF load with Vs=3.3V and 15pF load with Vs= 2.5V and 15pF load
Signal Level (Voh)	4.5 3.0 2.25			VDC VDC VDC	with Vs=5.0V and 15pF load with Vs=3.3V and 15pF load with Vs=2.5V and 15pF load
Rise and fall times for ACMOS (measured 10% to 90%)			10 6 3	ns ns ns	1.0 to 23.9 MHz 24.0 to 79.9 MHz 80.0 to 125.0 MHz
Duty cycle	45 40		55 60	% %	@ 50% < 15 MHz @ 50% => 15 MHz
Signal	TTL				
Load			10	pF	
Signal Level (Vol)			0.4	VDC	with Vs=5.0V and 15pF load
Signal Level (Voh)	2.4			VDC	with Vs=5.0V and 15pF load
Rise and fall times for ACMOS (measured 20% to 80%)			5 3	ns ns	1.0 to 23.9 MHz 24.0 to 125 MHz
Duty cycle	45 40		55 60	% %	@ 1.4V < 15 MHz @ 1.4V >= 15 MHz
Signal	LVPECL				
Load			50	ohm	into Vcc-2V or There in Equivalent
Signal Level (Vol)			Vs -1.62	VDC	-40....+85°C operating temp
Signal Level (Voh)	Vs- 1.025			VDC	-40....+85°C operating temp
Rise and fall times for ACMOS (measured 20% to 80%)			1000 600	ps ps	< 100 MHz >= 100 MHz

Parameter	Min	Typ	Max	Units	Condition
Duty cycle	45		55	%	@ 50% Vdd
Jitter (rms)			10 0.5	ps ps	BW = 10Hz to 20 MHz BW = 12KHz to 20 MHz
Period Jitter (pk-pk)			40	ps	10,000 Samples - Rising edge
Signal	LVDS				
Load	60	100	140	ohm	Between outputs
Signal Level (Vol)		1.2		VDC	
Signal Level (Voh)		1.4		VDC	
Differential Voltage (Vod)	240	330	460	mVpeak	
Common Mode (Offset) Voltage (Vos)	1.125	1.2	1.375	V	
Start-up Time			10	ms	
Rise \ Fall Time		600	1000	ps	measured @ 20% to 80% of Vod
Duty cycle	45		55	%	@ 50% of Vod
Jitter (rms)			5 1	ps ps	BW = 10Hz to 20 MHz BW = 12KHz to 20 MHz
Period Jitter (pk-pk)			40	ps	10,000 Samples - Rising edge
<b>Absolute Maximum Ratings</b>					
Supply voltage (Vs)			7.0	V	with Vs=5.0VDC and 3.3 VDC
Operable temperature range	-55		+125	°C	
Storage temperature range	-62		+125	°C	

Additional Parameters		
Screening	Vectron Verification	
	Class B, MIL-PRF-55310, Rev.E	
Output Enable	Logic "0" input = Outputs disabled (Tri-state) Logic "1" or floating input = Outputs enabled)	
	Logic "0" or floating input = Outputs enabled Logic "1" input = Outputs disabled (Tri-state)	
Weight	< 2 grams	
Processing & Packing	Handling & processing note	

Standard Environmentals	
Vibration	MIL-STD-202, Method 204, Condition G (30 G, 10Hz-2000Hz)
Shock	MIL-STD-202, Method 213, Condition I (100 G, 6ms, Sawtooth)
Acceleration	MIL-STD-883, Method 2001, Condition A (5000 G, Y1 Plane)
Temperature Cycling	MIL-STD-883, Method 1010, Condition B
Thermal Shock	MIL-STD-883, Method 107, Condition B
Solderability	MIL-STD-202, Method 208
Leak Test (Fine and Gross)	MIL-STD-883, Method 1014, Condition A1 and C1

## Outline Drawing / Enclosure

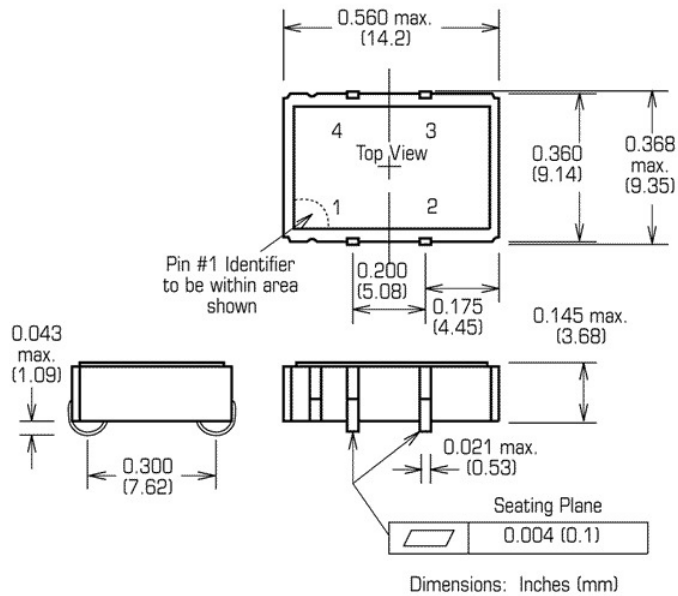

### Type A (ACMOS or TTL)

Code	Height "H"	Stand-off
0	0.188 (4.77mm)	0.043 (1.09mm)

### Pin Connections

1	Enable/Disable or N/C
2	Ground (Case)
3	Output
4	Supply

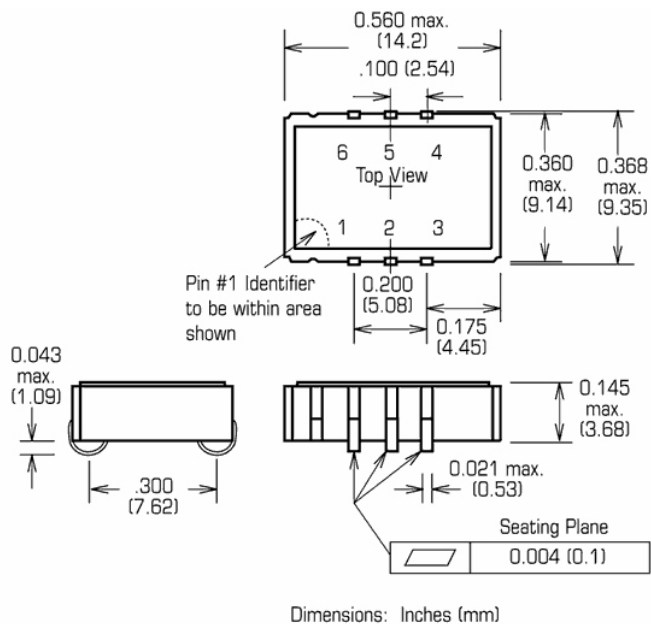

### Type B (LVPECL or LVDS)

Code	Height "H"	Stand-off
1	0.188 (4.77mm)	0.043 (1.09mm)

### Pin Connections

1	Enable/Disable or N/C
2	Enable/Disable or N/C (custom number required)
3	Ground (Case)
4	Output
5	Complementary Output
6	Supply

## Ordering Information

**PX - 500 0 - A A T - E K X B - 10M0000000**

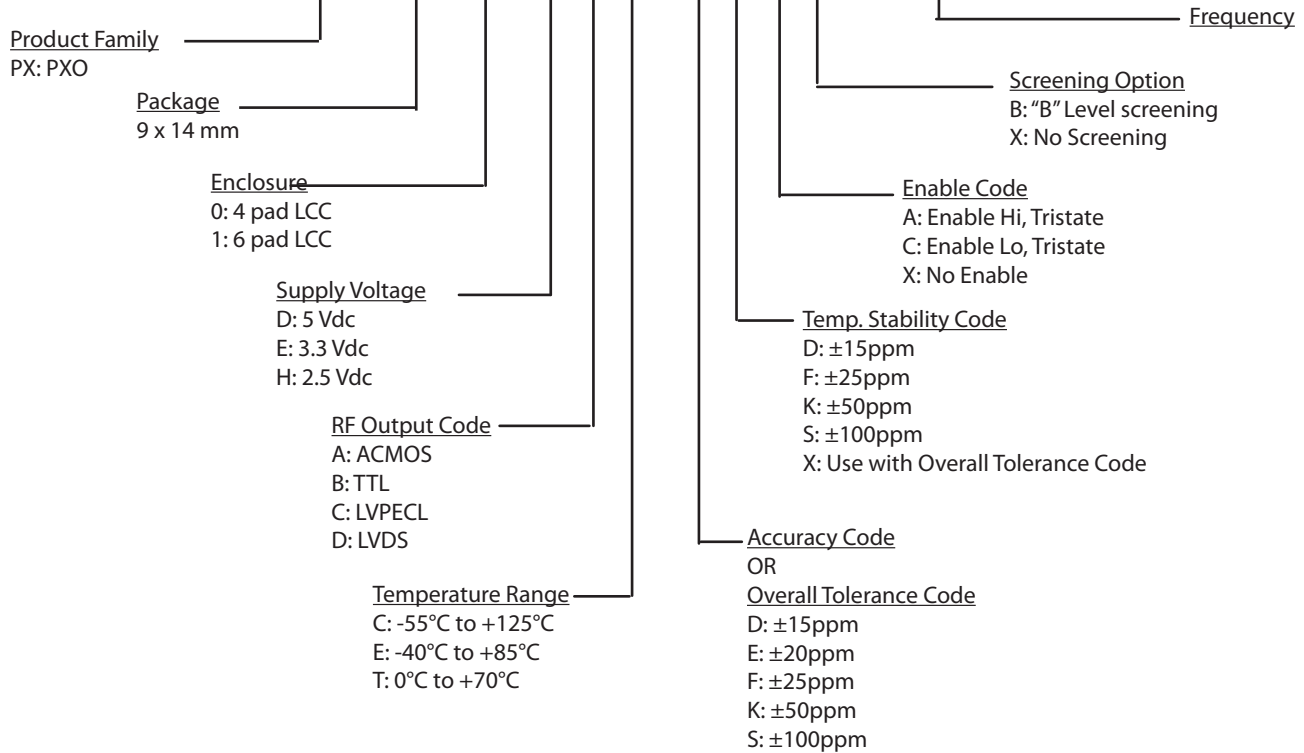

### Notes:

1. Contact factory for improved stabilities or additional product options. Not all options and codes are available at all frequencies.
2. Unless other stated all values are valid after warm-up time and refer to typical conditions for supply voltage, frequency control voltage, load, temperature (25°C).
3. Phase noise degrades with increasing output frequency.
4. Subject to technical modification.
5. Contact factory for availability.

## For Additional Information, Please Contact

### USA:

Vectron International  
267 Lowell Road  
Hudson, NH 03051  
Tel: 1.888.328.7661  
Fax: 1.888.329.8328

### Europe:

Vectron International  
Landstrasse, D-74924  
Neckarbischofsheim, Germany  
Tel: +49 (0) 3328.4784.17  
Fax: +49 (0) 3328.4784.30

### Asia:

Vectron International  
68 Yin Cheng Road(C), 22nd Floor  
One LuJiaZui  
Pudong, Shanghai 200120, China  
Tel: 86.21.6194.6886  
Fax: 86.21.6194.6699

### Disclaimer

Vectron International reserves the right to make changes to the product(s) and or information contained herein without notice. No liability is assumed as a result of their use or application. No rights under any patent accompany the sale of any such product(s) or information.

Rev: 2/18/2014 JV