

REMOTE CONTROL COMMANDER IC

■ GENERAL DESCRIPTION

The NJU6014 is a remote control commander IC, and generates the control code according to the key input of 4 x 8 matrix. It contains auto clear circuit, carrier generator, key input / key scan output circuit, extension code generator, data ROM and operated single power supply.

The NJU6014 has the stand-by mode using auto clear function with external capacitance.

The transmission code is using a Pulse Position Modulation (PPM) method and its transmission by the IR-LED. Maximum 40 - pattern output is available by programming the PLA and custom code ROM.

■ FEATURES

- Transmission Code — Pulse Position Modulation
- Generating Pattern — Fixed by PLA and ROM
- Frame Number Setting — 1 to 8 frame
- Internal Oscillation Circuit
- Power On Initialization
- Stand-by Mode — 1  $\mu$ A Max.
- Low Power Consumption
- Low Operating Voltage — 1.1 ~ 1.8V
- Package Outline — SSOP 20 / SOP 20 / SDIP 22
- C-MOS Technology

■ BLOCK DIAGRAM

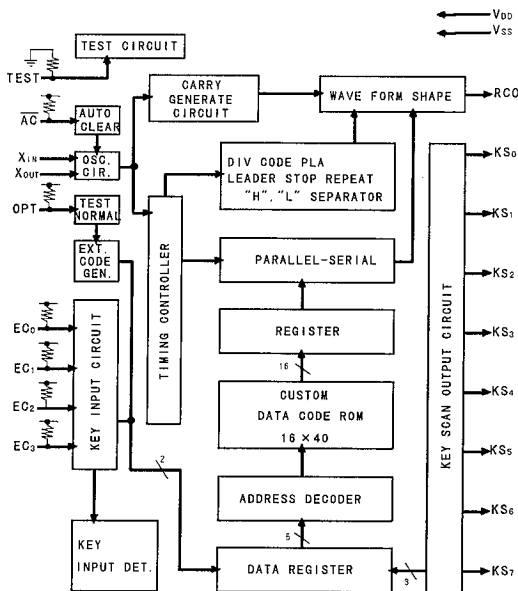

■ PACKAGE OUTLINE

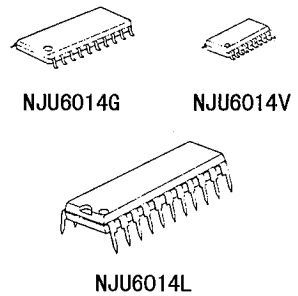

■ PIN CONFIGURATION

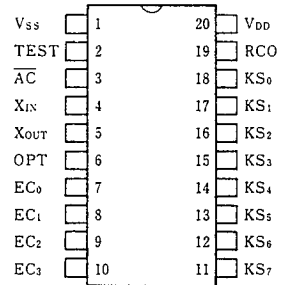

NJU6014G/V

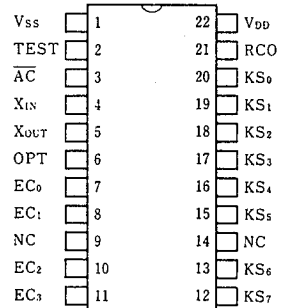

NJU6014L

**■ TERMINAL DESCRIPTION**

NO.		SYMBOL	FUNCTION
NJU6014G/V	NJU6014L		
1	1	V <sub>SS</sub>	GND
2	2	TEST	Testing Terminal (Normally OPEN, Internal Pull-down Resistance)
3	3	AC	Auto Clear Terminal (Internal Pull-up Resistance) Power on initialization is executed by connecting a capacitance to this.
4, 5	4, 5	X <sub>IN</sub> , X <sub>OUT</sub>	Oscillation Inverter Input / Output Terminal (Internal Feedback Resistance) This connects a ceramic resonator.
6	6	OPT	Extension Key Input Terminal (Internal Pull-up Resistance) The keys are extended by connecting with switches between the OPT terminal and the key scan terminals KS <sub>6</sub> and KS <sub>7</sub> .
7~10	7, 8, 10, 11	EC <sub>0</sub> ~EC <sub>3</sub>	Key Matrix Input Terminal (Internal Pull-up Resistance) The RCO output is started when this key input is perceived after 36msec period.
11~18	12, 13 15~20	KS <sub>7</sub> ~KS <sub>0</sub>	Key Scan Output Terminal Key scan time is 0.42msec. In case using maximum 32 keys, all scan time is about 36msec in high speed.
19	21	RCO	Remote Control Oscillation Terminal The pulse line of the transmission cord modulated by carrier wave is output. This pulse operates the IR-LED by driving the base of an external NPN transistor.
20	22	V <sub>DD</sub>	Power Supply Voltage range is wide from 1.1V to 1.8V, therefore it is single battery (1.5V) enough to operate. Except for key operation, operating current (stand-by current) is dropped under 1uA by stopping oscillation.
—	9, 14	NC	Non Connection

**■ FUNCTIONAL DESCRIPTION**
**(1) Oscillation Circuit**

The NJU6014 incorporates an internal oscillation circuit, therefore, when a ceramic resonator is connected the terminals X<sub>IN</sub> and X<sub>OUT</sub>, carrier wave of a transmission signal is generated inside.

**(2) Key Matrix**

The key of 4×8 matrix consists the inputs EC<sub>0</sub> to EC<sub>3</sub> and the key scan outputs KS<sub>0</sub> to KS<sub>7</sub>. And Keys are extended by combining the OPT terminal and the terminals KS<sub>6</sub> and KS<sub>7</sub>.

**(3) Transmission Signal**
**(3-1) Data Format**

The NJU6014 has 14 kinds of the data transmission format as shown in Table 1.

Table 1 Data Transmission Format in NJU6014

Wave Type	Date Line Up																																																																					
1	<table border="1"> <tr> <td colspan="8">Custom Code 8bit</td> <td colspan="8">Custom Code 8bit</td> <td colspan="8">Data Code 8bit</td> <td colspan="8">Data Code 8bit</td> <td>Stop</td> <td>Repeat</td> </tr> <tr> <td>Leader</td><td>C1</td><td>C2</td><td>C3</td><td>C4</td><td>C5</td><td>C6</td><td>C7</td><td>C8</td> <td>C1</td><td>C2</td><td>C3</td><td>C4</td><td>C5</td><td>C6</td><td>C7</td><td>C8</td> <td>D1</td><td>D2</td><td>D3</td><td>D4</td><td>D5</td><td>D6</td><td>D7</td><td>D8</td> <td>D1</td><td>D2</td><td>D3</td><td>D4</td><td>D5</td><td>D6</td><td>D7</td><td>D8</td> <td></td><td></td> </tr> </table>	Custom Code 8bit								Custom Code 8bit								Data Code 8bit								Data Code 8bit								Stop	Repeat	Leader	C1	C2	C3	C4	C5	C6	C7	C8	C1	C2	C3	C4	C5	C6	C7	C8	D1	D2	D3	D4	D5	D6	D7	D8	D1	D2	D3	D4	D5	D6	D7	D8		
Custom Code 8bit								Custom Code 8bit								Data Code 8bit								Data Code 8bit								Stop	Repeat																																					
Leader	C1	C2	C3	C4	C5	C6	C7	C8	C1	C2	C3	C4	C5	C6	C7	C8	D1	D2	D3	D4	D5	D6	D7	D8	D1	D2	D3	D4	D5	D6	D7	D8																																						
2	<table border="1"> <tr> <td colspan="8">Custom Code 8bit</td> <td colspan="8">Data Code 8bit</td> <td>Stop</td> </tr> <tr> <td>Leader</td><td>C1</td><td>C2</td><td>C3</td><td>C4</td><td>C5</td><td>C6</td><td>C7</td><td>C8</td> <td>D1</td><td>D2</td><td>D3</td><td>D4</td><td>D5</td><td>D6</td><td>D7</td><td>D8</td> <td></td> </tr> </table>	Custom Code 8bit								Data Code 8bit								Stop	Leader	C1	C2	C3	C4	C5	C6	C7	C8	D1	D2	D3	D4	D5	D6	D7	D8																																			
Custom Code 8bit								Data Code 8bit								Stop																																																						
Leader	C1	C2	C3	C4	C5	C6	C7	C8	D1	D2	D3	D4	D5	D6	D7	D8																																																						
3	<table border="1"> <tr> <td colspan="8">Data Code 6bit</td> <td>Stop</td> </tr> <tr> <td>D1</td><td>D2</td><td>D3</td><td>D4</td><td>D5</td><td>D6</td> <td></td> </tr> </table>	Data Code 6bit								Stop	D1	D2	D3	D4	D5	D6																																																						
Data Code 6bit								Stop																																																														
D1	D2	D3	D4	D5	D6																																																																	
4	<table border="1"> <tr> <td colspan="10">Data Code 10bit</td> <td>Stop</td> </tr> <tr> <td>D1</td><td>2</td><td>3</td><td>4</td><td>5</td><td>6</td><td>7</td><td>8</td><td>9</td><td>10</td> <td></td> </tr> </table>	Data Code 10bit										Stop	D1	2	3	4	5	6	7	8	9	10																																																
Data Code 10bit										Stop																																																												
D1	2	3	4	5	6	7	8	9	10																																																													
5	<table border="1"> <tr> <td colspan="8">Custom Code 8bit</td> <td colspan="8">Custom Code 8bit</td> <td colspan="8">Data Code 8bit</td> <td colspan="8">Data Code 8bit</td> <td>Stop</td> </tr> <tr> <td>Leader</td><td>C1</td><td>C2</td><td>C3</td><td>C4</td><td>C5</td><td>C6</td><td>C7</td><td>C8</td> <td>C1</td><td>C2</td><td>C3</td><td>C4</td><td>C5</td><td>C6</td><td>C7</td><td>C8</td> <td>D1</td><td>D2</td><td>D3</td><td>D4</td><td>D5</td><td>D6</td><td>D7</td><td>D8</td> <td>D1</td><td>D2</td><td>D3</td><td>D4</td><td>D5</td><td>D6</td><td>D7</td><td>D8</td> <td></td> </tr> </table>	Custom Code 8bit								Custom Code 8bit								Data Code 8bit								Data Code 8bit								Stop	Leader	C1	C2	C3	C4	C5	C6	C7	C8	C1	C2	C3	C4	C5	C6	C7	C8	D1	D2	D3	D4	D5	D6	D7	D8	D1	D2	D3	D4	D5	D6	D7	D8			
Custom Code 8bit								Custom Code 8bit								Data Code 8bit								Data Code 8bit								Stop																																						
Leader	C1	C2	C3	C4	C5	C6	C7	C8	C1	C2	C3	C4	C5	C6	C7	C8	D1	D2	D3	D4	D5	D6	D7	D8	D1	D2	D3	D4	D5	D6	D7	D8																																						
6	<table border="1"> <tr> <td colspan="10">Address5</td> <td colspan="2">Data6</td> <td>Option2</td> <td>Mask1</td> <td>Check1</td> <td colspan="10">Address5</td> <td colspan="2">Data6</td> <td>Option2</td> <td>Mask1</td> <td>Check1</td> <td>Stop</td> </tr> <tr> <td>A1</td><td>A2</td><td>A3</td><td>A4</td><td>A5</td><td>D1</td><td>D2</td><td>D3</td><td>D4</td><td>D5</td><td>D6</td><td>D10</td><td>M1</td><td>H1</td> <td>A1</td><td>A2</td><td>A3</td><td>A4</td><td>A5</td><td>D1</td><td>D2</td><td>D3</td><td>D4</td><td>D5</td><td>D6</td><td>D10</td><td>M1</td><td>H1</td> <td></td> </tr> </table>	Address5										Data6		Option2	Mask1	Check1	Address5										Data6		Option2	Mask1	Check1	Stop	A1	A2	A3	A4	A5	D1	D2	D3	D4	D5	D6	D10	M1	H1	A1	A2	A3	A4	A5	D1	D2	D3	D4	D5	D6	D10	M1	H1										
Address5										Data6		Option2	Mask1	Check1	Address5										Data6		Option2	Mask1	Check1	Stop																																								
A1	A2	A3	A4	A5	D1	D2	D3	D4	D5	D6	D10	M1	H1	A1	A2	A3	A4	A5	D1	D2	D3	D4	D5	D6	D10	M1	H1																																											
7	<table border="1"> <tr> <td colspan="12">Data Code 12bit</td> <td>Stop</td> </tr> <tr> <td>D1</td><td>2</td><td>3</td><td>4</td><td>5</td><td>6</td><td>7</td><td>8</td><td>9</td><td>10</td><td>11</td><td>12</td> <td></td> </tr> </table>	Data Code 12bit												Stop	D1	2	3	4	5	6	7	8	9	10	11	12																																												
Data Code 12bit												Stop																																																										
D1	2	3	4	5	6	7	8	9	10	11	12																																																											
8	<table border="1"> <tr> <td colspan="12">Data Code 12bit</td> <td>Stop</td> </tr> <tr> <td>Leader</td><td>D1</td><td>2</td><td>3</td><td>4</td><td>5</td><td>6</td><td>7</td><td>8</td><td>9</td><td>10</td><td>11</td><td>12</td> <td></td> </tr> </table>	Data Code 12bit												Stop	Leader	D1	2	3	4	5	6	7	8	9	10	11	12																																											
Data Code 12bit												Stop																																																										
Leader	D1	2	3	4	5	6	7	8	9	10	11	12																																																										
9	<table border="1"> <tr> <td colspan="8">Custom Code 8bit</td> <td colspan="8">Data Code 8bit</td> <td>Stop</td> </tr> <tr> <td>Leader</td><td>C1</td><td>C2</td><td>C3</td><td>C4</td><td>C5</td><td>C6</td><td>C7</td><td>C8</td> <td>Separator</td><td>D1</td><td>D2</td><td>D3</td><td>D4</td><td>D5</td><td>D6</td><td>D7</td><td>D8</td> <td></td> </tr> </table>	Custom Code 8bit								Data Code 8bit								Stop	Leader	C1	C2	C3	C4	C5	C6	C7	C8	Separator	D1	D2	D3	D4	D5	D6	D7	D8																																		
Custom Code 8bit								Data Code 8bit								Stop																																																						
Leader	C1	C2	C3	C4	C5	C6	C7	C8	Separator	D1	D2	D3	D4	D5	D6	D7	D8																																																					
10	<table border="1"> <tr> <td colspan="8">Custom Code 8bit</td> <td colspan="8">Custom Code 8bit</td> <td colspan="8">Data Code 8bit</td> <td colspan="8">Data Code 8bit</td> <td>Stop</td> <td>Repeat</td> </tr> <tr> <td>Leader</td><td>C1</td><td>C2</td><td>C3</td><td>C4</td><td>C5</td><td>C6</td><td>C7</td><td>C8</td> <td>C1</td><td>C2</td><td>C3</td><td>C4</td><td>C5</td><td>C6</td><td>C7</td><td>C8</td> <td>D1</td><td>D2</td><td>D3</td><td>D4</td><td>D5</td><td>D6</td><td>D7</td><td>D8</td> <td>D1</td><td>D2</td><td>D3</td><td>D4</td><td>D5</td><td>D6</td><td>D7</td><td>D8</td> <td></td><td></td> </tr> </table>	Custom Code 8bit								Custom Code 8bit								Data Code 8bit								Data Code 8bit								Stop	Repeat	Leader	C1	C2	C3	C4	C5	C6	C7	C8	C1	C2	C3	C4	C5	C6	C7	C8	D1	D2	D3	D4	D5	D6	D7	D8	D1	D2	D3	D4	D5	D6	D7	D8		
Custom Code 8bit								Custom Code 8bit								Data Code 8bit								Data Code 8bit								Stop	Repeat																																					
Leader	C1	C2	C3	C4	C5	C6	C7	C8	C1	C2	C3	C4	C5	C6	C7	C8	D1	D2	D3	D4	D5	D6	D7	D8	D1	D2	D3	D4	D5	D6	D7	D8																																						
11	<table border="1"> <tr> <td colspan="4">Custom Code 6bit</td> <td colspan="4">Data Code 6bit</td> <td colspan="4">Custom Code 6bit</td> <td colspan="4">Data Code 6bit</td> <td>Stop</td> </tr> <tr> <td>Leader</td><td>C1</td><td>C2</td><td>C3</td><td>C4</td><td>C5</td><td>C6</td><td>D1</td><td>D2</td><td>D3</td><td>D4</td><td>D5</td><td>D6</td> <td>C1</td><td>C2</td><td>C3</td><td>C4</td><td>C5</td><td>C6</td><td>D1</td><td>D2</td><td>D3</td><td>D4</td><td>D5</td><td>D6</td> <td></td> </tr> </table>	Custom Code 6bit				Data Code 6bit				Custom Code 6bit				Data Code 6bit				Stop	Leader	C1	C2	C3	C4	C5	C6	D1	D2	D3	D4	D5	D6	C1	C2	C3	C4	C5	C6	D1	D2	D3	D4	D5	D6																											
Custom Code 6bit				Data Code 6bit				Custom Code 6bit				Data Code 6bit				Stop																																																						
Leader	C1	C2	C3	C4	C5	C6	D1	D2	D3	D4	D5	D6	C1	C2	C3	C4	C5	C6	D1	D2	D3	D4	D5	D6																																														
12	<table border="1"> <tr> <td colspan="2">Custom Code 5bit</td> <td colspan="3">Data Code 6bit</td> <td colspan="2">Custom Code 5bit</td> <td colspan="3">Data Code 6bit</td> <td>Stop</td> </tr> <tr> <td>Leader</td><td>C1</td><td>C2</td><td>C3</td><td>C4</td><td>C5</td><td>D1</td><td>D2</td><td>D3</td><td>D4</td><td>D5</td><td>D6</td> <td>C1</td><td>C2</td><td>C3</td><td>C4</td><td>C5</td><td>D1</td><td>D2</td><td>D3</td><td>D4</td><td>D5</td><td>D6</td> <td></td> </tr> </table>	Custom Code 5bit		Data Code 6bit			Custom Code 5bit		Data Code 6bit			Stop	Leader	C1	C2	C3	C4	C5	D1	D2	D3	D4	D5	D6	C1	C2	C3	C4	C5	D1	D2	D3	D4	D5	D6																																			
Custom Code 5bit		Data Code 6bit			Custom Code 5bit		Data Code 6bit			Stop																																																												
Leader	C1	C2	C3	C4	C5	D1	D2	D3	D4	D5	D6	C1	C2	C3	C4	C5	D1	D2	D3	D4	D5	D6																																																
13	<table border="1"> <tr> <td colspan="4">Custom Code 8bit</td> <td colspan="4">Data Code 8bit</td> <td>Stop</td> </tr> <tr> <td>C1</td><td>C2</td><td>C3</td><td>C4</td><td>C5</td><td>C6</td><td>C7</td><td>C8</td><td>D1</td><td>D2</td><td>D3</td><td>D4</td><td>D5</td><td>D6</td><td>D7</td><td>D8</td> <td></td> </tr> </table>	Custom Code 8bit				Data Code 8bit				Stop	C1	C2	C3	C4	C5	C6	C7	C8	D1	D2	D3	D4	D5	D6	D7	D8																																												
Custom Code 8bit				Data Code 8bit				Stop																																																														
C1	C2	C3	C4	C5	C6	C7	C8	D1	D2	D3	D4	D5	D6	D7	D8																																																							
14	<table border="1"> <tr> <td colspan="8">Custom Code 8bit</td> <td colspan="8">Custom Code 8bit</td> <td colspan="8">Data Code 8bit</td> <td colspan="8">Data Code 8bit</td> <td>Stop</td> <td>Repeat</td> </tr> <tr> <td>Leader</td><td>C1</td><td>C2</td><td>C3</td><td>C4</td><td>C5</td><td>C6</td><td>C7</td><td>C8</td> <td>C1</td><td>C2</td><td>C3</td><td>C4</td><td>C5</td><td>C6</td><td>C7</td><td>C8</td> <td>D1</td><td>D2</td><td>D3</td><td>D4</td><td>D5</td><td>D6</td><td>D7</td><td>D8</td> <td>D1</td><td>D2</td><td>D3</td><td>D4</td><td>D5</td><td>D6</td><td>D7</td><td>D8</td> <td></td><td></td> </tr> </table>	Custom Code 8bit								Custom Code 8bit								Data Code 8bit								Data Code 8bit								Stop	Repeat	Leader	C1	C2	C3	C4	C5	C6	C7	C8	C1	C2	C3	C4	C5	C6	C7	C8	D1	D2	D3	D4	D5	D6	D7	D8	D1	D2	D3	D4	D5	D6	D7	D8		
Custom Code 8bit								Custom Code 8bit								Data Code 8bit								Data Code 8bit								Stop	Repeat																																					
Leader	C1	C2	C3	C4	C5	C6	C7	C8	C1	C2	C3	C4	C5	C6	C7	C8	D1	D2	D3	D4	D5	D6	D7	D8	D1	D2	D3	D4	D5	D6	D7	D8																																						

Note 1) Each wave form is available as the masked ROM option.

### (3-2) The Number of Output Frame

The number of transmission signal frame generated by minimum key input time is available as the masked ROM option. It has from 1 frame to 8 frame.

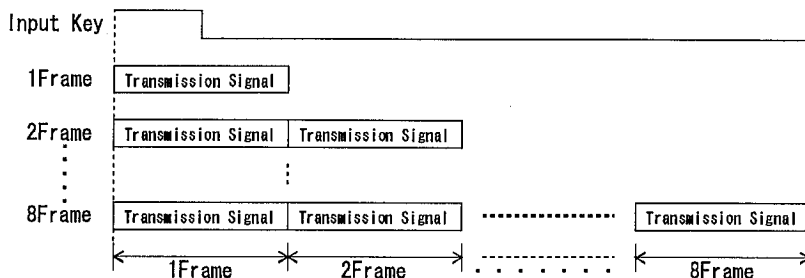

### (4) Key Operation

#### (4-1) Standard Key Operation

The key board matrix correspond to the ROM code address is shown as follows:

Standard Key Matrix				
Key Scan	EC <sub>0</sub>	EC <sub>1</sub>	EC <sub>2</sub>	EC <sub>3</sub>
KS <sub>0</sub>	00 (KY1)	08 (KY9)	16 (KY17)	24 (KY25)
KS <sub>1</sub>	01 (KY2)	09 (KY10)	17 (KY18)	25 (KY26)
KS <sub>2</sub>	02 (KY3)	10 (KY11)	18 (KY19)	26 (KY27)
KS <sub>3</sub>	03 (KY4)	11 (KY12)	19 (KY20)	27 (KY28)
KS <sub>4</sub>	04 (KY5)	12 (KY13)	20 (KY21)	28 (KY29)
KS <sub>5</sub>	05 (KY6)	13 (KY14)	21 (KY22)	29 (KY30)
KS <sub>6</sub>	06 (KY7)	14 (KY15)	22 (KY23)	30 (KY31)
KS <sub>7</sub>	07 (KY8)	15 (KY16)	23 (KY24)	31 (KY32)

Note 2) The inside of parentheses means the key number.

Only for standard key operation, when the roll over input occurs, the transmission data in the data register is cleared by the roll over preventive circuit and the transmission is forbid.

#### (4-2) Extension Key Operation

The extension key is connected between the OPT terminal and the key scan output terminal KS<sub>5</sub> or KS<sub>7</sub>, key board matrix correspond to ROM code address is shown as follows:

Key Scan	Standard Key Matrix				Extension Key Matrix				OPT
	EC <sub>0</sub>	EC <sub>1</sub>	EC <sub>2</sub>	EC <sub>3</sub>	EC <sub>0</sub>	EC <sub>1</sub>	EC <sub>2</sub>	EC <sub>3</sub>	
KS <sub>0</sub>	00 (KY1)	08 (KY9)	16 (KY17)	24 (KY25)	No Extension Key				
KS <sub>1</sub>	01 (KY2)	09 (KY10)	17 (KY18)	25 (KY26)					
KS <sub>2</sub>	02 (KY3)	10 (KY11)	18 (KY19)	26 (KY27)					
KS <sub>3</sub>	03 (KY4)	11 (KY12)	19 (KY20)	27 (KY28)					
KS <sub>4</sub>	04 (KY5)	12 (KY13)	20 (KY21)	28 (KY29)					
KS <sub>5</sub>	05 (KY6)	13 (KY14)	21 (KY22)	29 (KY30)					
KS <sub>6</sub>	06 (KY7)	14 (KY15)	22 (KY23)	30 (KY31)	20	21	22	23	KY33
KS <sub>7</sub>	07 (KY8)	15 (KY16)	23 (KY24)	31 (KY32)	24	25	26	27	KY34

The extension key is formed by the KY33 and the KY34, and it is generated the extension code by operating with the combination key.

The combination key corresponded to the extension key is as follows:

Extension key	Combination Key			
KY33	KY7	KY15	KY23	KY31
KY34	KY8	KY16	KY24	KY32

It is correspondence as this table, therefore any other combinations aren't transmitted, besides, only extension key KY33 or KY34 isn't transmitted. The extension key should be pushed with the combination key.

#### (4-3) Key Timing Prevented Of Two Key Roll Over

The timing of key scan is 0.42msec. The time to stop scanning is about 36msec. Besides, to prevent chattering of key ON, a data isn't read for 9msec after pressing a key. Therefore the key timing prevented of two key roll over is as follow:

- ① Pressing At The Same Time Within 36msec → Forbidding Transmission

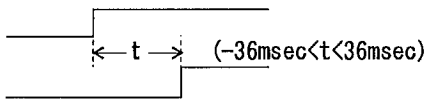

↑ Key ON

- ② Pressing Second Key after 36msec

→ After Transmitting First Key Data, Forbidding Transmission

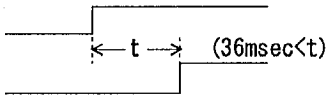

↑ Key ON

- ③ Taking Off Both Key Within 36msec

→ Forbidding Transmission

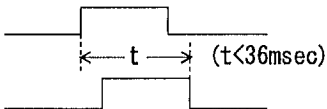

↑ Key ON      ↓ Key OFF

- ④ Taking Off The Other Key After 36msec

→ Transmitting Rest Key Data

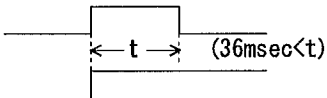

↑ Key ON

As this, provided an key is kept to press over 36msec, its code is transmitted once.

#### (4-4) Roll Over Timing Of Extension Key

When keys are pressed over two at the same time, transmission is usually forbid by the roll over preventive circuit. However, when the extension key is pressed, it is transmitted by operating with the combination key at input timing as follows:

## ① Extension Key Signal Transmission

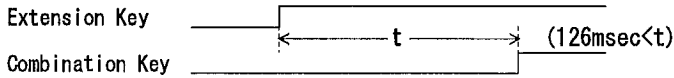

## ② Forbidding Extension Key Signal Transmission

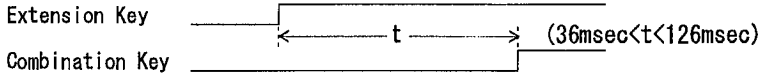

## ③ Forbidding Extension Key Signal Transmission

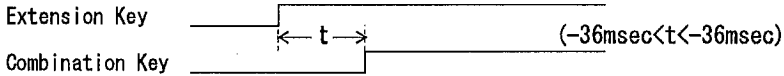

## ④ Forbidding Extension Key Signal Transmission

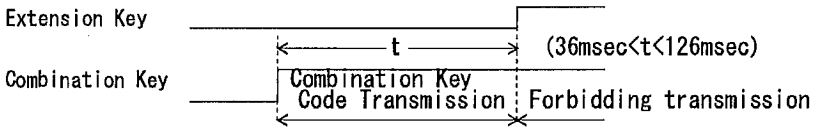

For the order of the priority of pressing key, the extension key can operate when only the combination key is pressed after 126msec at the time of pressing the extension key.

## (5) Carrier Frequency Generating Circuit

Each other ceramic resonator corresponded to the carrier wave frequency is shown below.

For ROM option, the ceramic resonator should be specified.

	Ceramics resonator fosc (kHz)				
	393	440	455	480	455
Carrier Frequency fca (kHz)	32.8	36.7	37.9	40.0	56.9
Dividing Frequency Percentage	fosc/12	fosc/12	fosc/12	fosc/12	fosc/8

The carrier frequency is output in 1/3 duty.

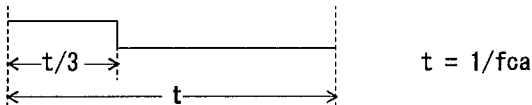

In case of using the ceramic resonator 455kHz and set the frequency dividing ratio to fosc/8, the carrier frequency is 1/2 duty.

### (6) Auto Clear Circuit

Connecting the capacitor between the  $\overline{AC}$  terminal and  $V_{SS}$ , auto clear function is executed at the time of power-on. After the  $V_{DD}$  terminal voltage is risen to 0.9V, it is required that the period ( $T_c$ ) which the  $\overline{AC}$  terminal voltage ( $V_c$ ) becomes  $V_c > 0.3V_{DD}$  is  $T_c > 0.1\text{msec}$ . After auto clear function is executed, this circuit is kept the stand-by mode until a key is input.

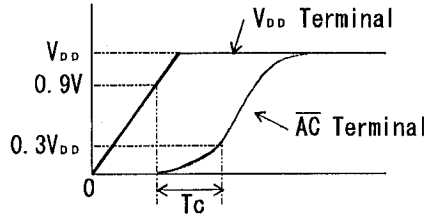
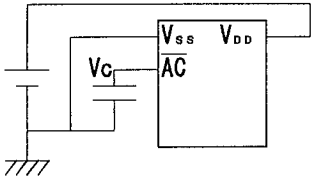

An external capacitance should be connected value more than 2nF.  
Example expressions are shown below.

• For example ( $V_{DD}=1.5\text{V}$  Operating)

- $V_{min}$ : Minimum Operating Voltage (1.1V)
- $V_c$ :  $\overline{AC}$  Terminal Voltage (0.3 $V_{DD}$ )
- $T_c$ : Time Until  $\overline{AC}$  Terminal is  $V_c > 0.3V$  (more than 0.1ms)
- $R$ : Internal Pull-Up Resistance (80k $\Omega$ )
- $C$ : External Capacitance

$$V_c = V_{min} \left(1 - e^{-\frac{T_c}{CR}}\right)$$

$$T_c = -CR \times \log\left(1 - \frac{V_c}{V_{min}}\right)$$

$$0.1(\text{ms}) \leq -C \times 80(\text{k}\Omega) \times \log\left(1 - \frac{0.45(\text{V})}{1.1(\text{V})}\right)$$

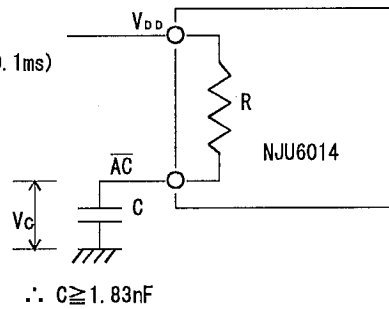

Therefore, in order to be executed auto clear function exactly, the capacitance more than this numerical value should be connected.

**■ ABSOLUTE MAXIMUM RATINGS**

(Ta=25°C)

PARAMETER	SYMBOL	RATINGS	UNIT
Supply Voltage	V <sub>DD</sub>	-0.3 ~ +3.0	V
Input Voltage	V <sub>IN</sub>	V <sub>SS</sub> -0.3 ~ V <sub>DD</sub> +0.3	V
Operating Temperature	Topr	- 25 ~ + 75	°C
Storage Temperature	Tstg	- 40 ~ + 125	°C

**■ ELECTRICAL CHARACTERISTICS**

 (V<sub>DD</sub>=1.2V, Ta=25°C)

PARAMETER	SYMBOL	CONDITIONS	MIN.	TYP.	MAX.	UNIT	NOTE
Operating Voltage	V <sub>DD</sub>	fosc=455kHz	1.1		1.8	V	
Operating Current	I <sub>DD</sub>	fosc=455kHz			0.6	mA	
Stand-by Current	I <sub>ST</sub>				1.0	μA	
"H" Input Voltage	V <sub>IH</sub>	Each EC, OPT Terminal	0.7V <sub>DD</sub>		V <sub>DD</sub>	V	
"L" Input Voltage	V <sub>IL</sub>	Each EC, OPT Terminal			0.3V <sub>DD</sub>	V	
Oscillation Frequency	fosc	X <sub>IN</sub> , X <sub>OUT</sub> Terminal		393 440 455 480		kHz	3
Output Current(1)	I <sub>OL1</sub>	V <sub>OL</sub> =0.3V	0.1	0.3		mA	
	I <sub>OH1</sub>	V <sub>OH</sub> =0.9V					
Output Current(2)	I <sub>OL2</sub>	V <sub>OL</sub> =0.9V	0.5	1.0		mA	
Feedback Resistance	R <sub>f</sub>	X <sub>IN</sub> =V <sub>DD</sub>		1		MΩ	
Pull-up Resistance	R <sub>11</sub>	OPT Terminal		100		kΩ	
	R <sub>12</sub>	Each EC Terminal		100			
	R <sub>13</sub>	AC Terminal		80			
Pull-down Resistance	R <sub>14</sub>	TEST Terminal		200		kΩ	

Note 3) The oscillation frequency is turned by depending the ceramic resonator.

The carrier frequency is the masked ROM option, therefore the ceramic resonator should be designated.



■ APPLICATION CIRCUIT

(1) Normal Key

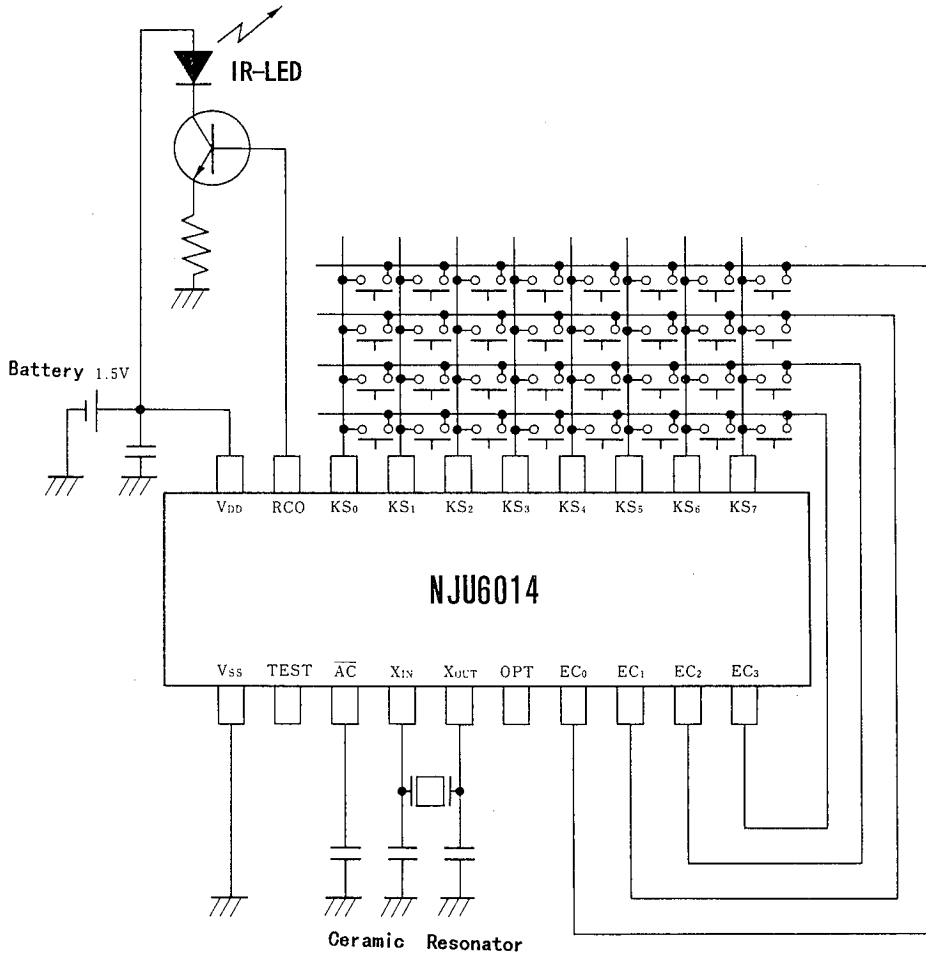

9

(2) Double Press Key

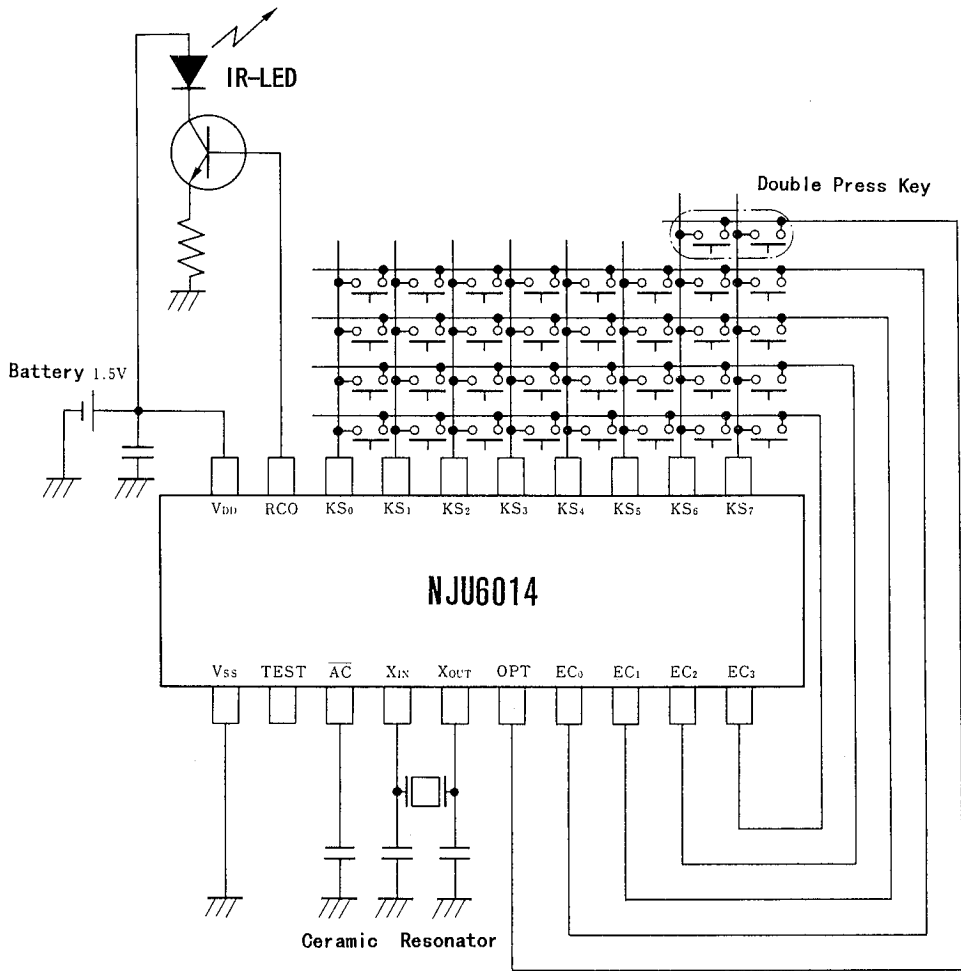

9

## MEMO

[CAUTION]

The specifications on this databook are only given for information, without any guarantee as regards either mistakes or omissions. The application circuits in this databook are described only to show representative usages of the product and not intended for the guarantee or permission of any right including the industrial rights.