

élantec

HIGH PERFORMANCE ANALOG INTEGRATED CIRCUITS

EL7262C/EL7272C

Dual Channel, High Speed, Power MOSFET w/Isolated Drains

Features

- Separate drain connections
- 3V and 5V Input compatible
- Clocking speeds up to 10 MHz
- 20 ns Switching/delay time
- 2A Peak drive
- Low output impedance
- Low quiescent current
- Wide operating voltage

Applications

- Asymmetrical switching
- Cascoded switching
- Resonant charging
- Floating load circuits
- Bridge circuits

Ordering Information

Part No.	Temp. Range	Pkg.	Outline #
EL7262CN	-40°C to +85°C	8-Pin P-DIP	MDP0031
EL7262CS	-40°C to +85°C	8-Pin SO	MDP0027
EL7272CN	-40°C to +85°C	8-Pin P-DIP	MDP0031
EL7272CS	-40°C to +85°C	8-Pin SO	MDP0027

General Description

The EL7262C/EL7272C, dual channel, power MOSFET drivers achieve the same excellent switching performance of the EL7202 family, with the added flexibility derived through the isolated drain architecture. The outputs can be configured in numerous ways, depending upon the application. The EL7262C and EL7272C are available in 8-pin P-DIP and 8-lead SO packages.

Connection Diagrams

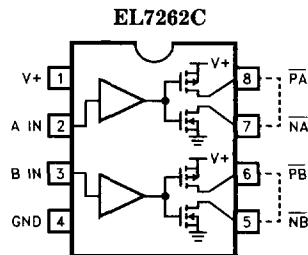

7262-1

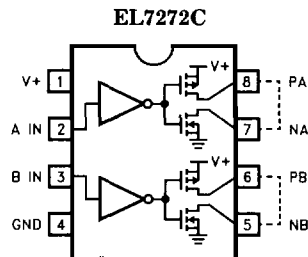

7262-2

Manufactured under U.S. Patent Nos. 5,334,883, # 5,341,047

EL7262C/EL7272C

Dual Channel, High Speed, Power MOSFET w/Isolated Drains

EL7262C/EL7272C

Absolute Maximum Ratings

Supply (V+ to Gnd)	16.5V	Operating Junction Temperature	125°C
Input Pins	-0.3V to +0.3V above V+	Power Dissipation	
Combined Peak Output Current	4A	SOIC	570 mW
Storage Temperature Range	-65°C to +150°C	PDIP	1050 mW
Ambient Operating Temperature	-40°C to +85°C		

Important Note:

All parameters having Min/Max specifications are guaranteed. The Test Level column indicates the specific device testing actually performed during production and Quality inspection. Elantec performs most electrical tests using modern high-speed automatic test equipment, specifically the LTX77 Series system. Unless otherwise noted, all tests are pulsed tests, therefore $T_J = T_C = T_A$.

Test Level	Test Procedure
I	100% production tested and QA sample tested per QA test plan QCX0002.
II	100% production tested at $T_A = 25^\circ\text{C}$ and QA sample tested at $T_A = 25^\circ\text{C}$, T_{MAX} and T_{MIN} per QA test plan QCX0002.
III	QA sample tested per QA test plan QCX0002.
IV	Parameter is guaranteed (but not tested) by Design and Characterization Data.
V	Parameter is typical value at $T_A = 25^\circ\text{C}$ for information purposes only.

DC Electrical Characteristics $T_A = 25^\circ\text{C}$, $V = 15\text{V}$ unless otherwise specified

Parameter	Description	Test Conditions	Min	Typ	Max	Test Level	Units
Input							
V_{IH}	Logic "1" Input Voltage		2.4			I	V
I_{IH}	Logic "1" Input Current	@V+		0.1	10	I	μA
V_{IL}	Logic "0" Input Voltage				0.8	I	V
I_{IL}	Logic "0" Input Current	@0V		0.1	10	I	μA
V_{HVS}	Input Hysteresis			0.3		V	V
Output							
R_{OH}	Pull-Up Resistance	$I_{OUT} = -100\text{ mA}$		3	6	I	Ω
R_{OL}	Pull-Down Resistance	$I_{OUT} = +100\text{ mA}$		4	6	I	Ω
I_{OFF}	Output Leakage	$V_{OUT} = V+$ $V_{OUT} = 0V$		0.2	10	I	μA
I_{PK}	Peak Output Current	Source Sink		2 2		IV	A
I_{DC}	Continuous Output Current	Source/Sink	100			I	mA
Power Supply							
I_S	Power Supply Current	Inputs EL7262 High EL7272		1 4.5	2.5 7.5	I	mA
V_S	Operating Voltage		4.5		16	I	V

5

EL7262C/EL7272C

Dual Channel, High Speed, Power MOSFET w/Isolated Drains

AC Electrical Characteristics $T_A = 25^\circ\text{C}$, $V = 15\text{V}$ unless otherwise specified

Parameter	Description	Test Conditions	Min	Typ	Max	Test Level	Units
t_R	Rise Time	$C_L = 500\text{ pF}$ $C_L = 1000\text{ pF}$		7.5 10	20	IV	ns
t_F	Fall Time	$C_L = 500\text{ pF}$ $C_L = 1000\text{ pF}$		10 13	20	IV	ns
t_{D-ON}	Turn-On Delay Time	See Timing Table		18	25	IV	ns
t_{D-OFF}	Turn-Off Delay Time	See Timing Table		20	25	IV	ns

Switching Characteristics

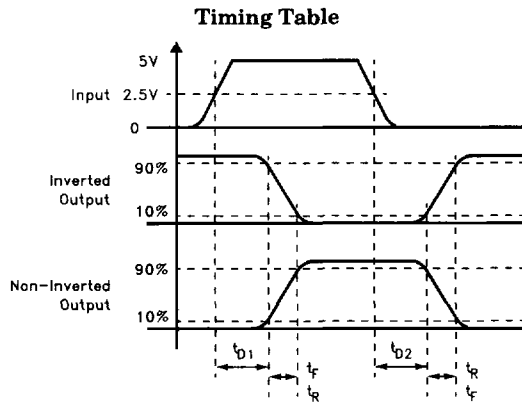

7262-3

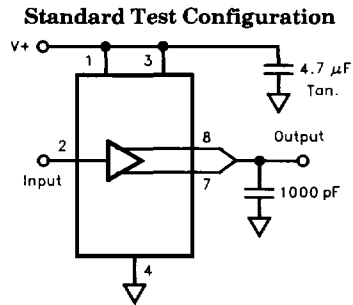

7262-4

Simplified Schematic

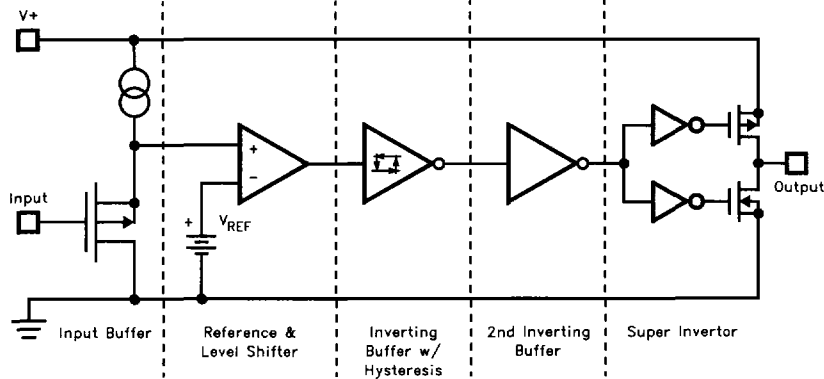

7262-5

EL7262C/EL7272C

Dual Channel, High Speed, Power MOSFET w/Isolated Drains

EL7262C/EL7272C

Typical Performance Curve

Max Power/Derating Curves

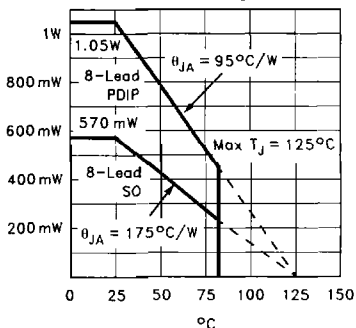

7262-12

Switch Threshold vs Supply Voltage

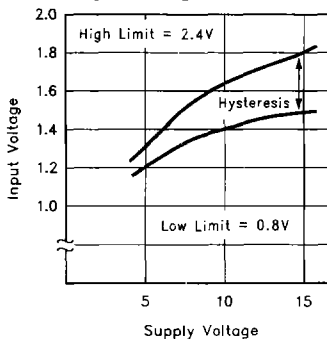

7262-6

Input Current vs Voltage

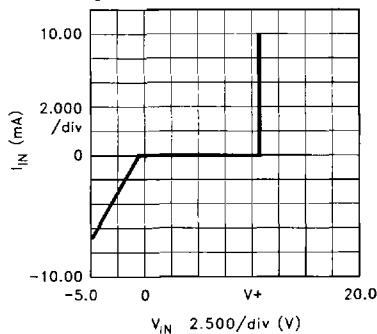

7262-7

Peak Drive vs Supply Voltage

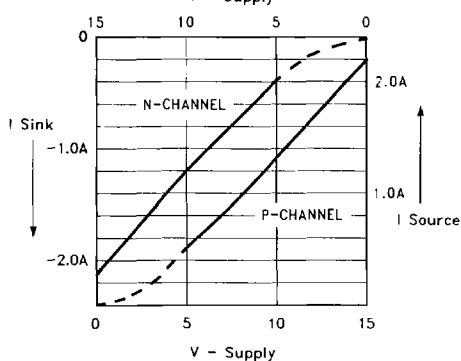

7262-8

Quiescent Supply Current

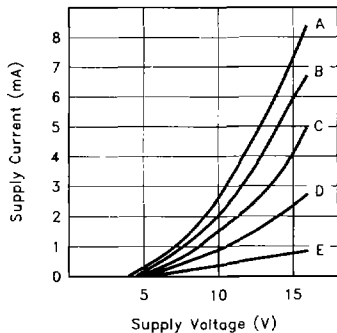

CASE:

Device	Input Level	Curve
EL7262	GND	C
EL7262	GND, V+	D
EL7262	V+	E
EL7272	GND	A
EL7272	GND, V+	B
EL7272	V+	C

"ON" Resistance vs Supply Voltage

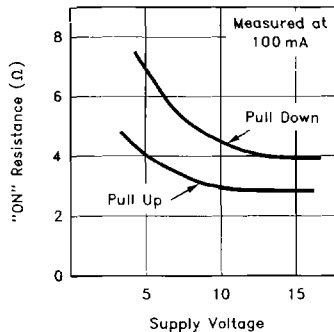

7262-9

7262-10

5

EL7262C/EL7272C

Dual Channel, High Speed, Power MOSFET w/Isolated Drains

Typical Performance Curve — Contd.

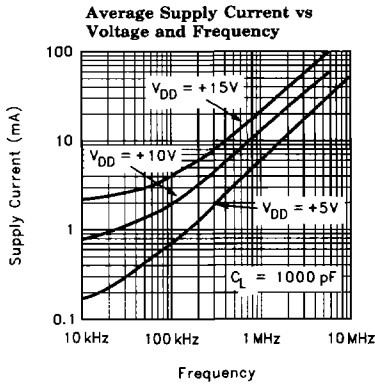

7262-13

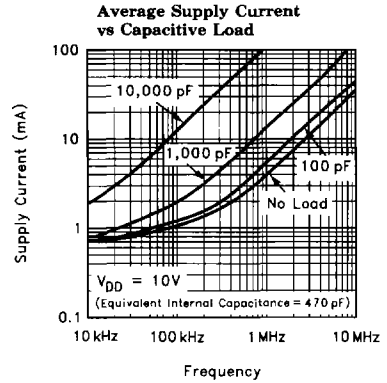

7262-14

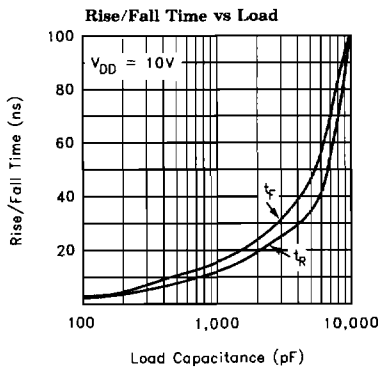

7262-11

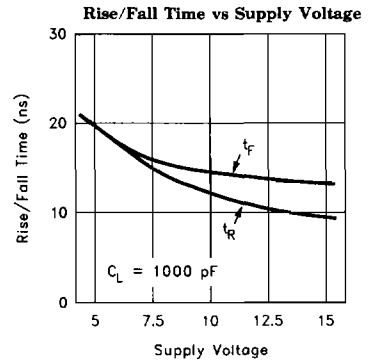

7262-15

EL7262C/EL7272C

Dual Channel, High Speed, Power MOSFET w/Isolated Drains

EL7262C/EL7272C

Typical Performance Curve — Contd.

