

T-SI-10-05

**TELEDYNE  
COMPONENTS**
**TC14433  
TC14433A  
TC14433B**

1

### 3-1/2 DIGIT ADC

#### FEATURES

- Accuracy:  $\pm 0.05\%$  of Reading  $\pm 1$  Count
- Two Voltage Ranges: 1.999V and 199.9 mV
- Up to 25 Conversions Per Second
- $Z_{IN} > 1000M$  Ohms
- Single Positive Voltage Reference
- Auto-Polarity and Auto-Zero
- Overrange and Underrange Signals Available
- Operates in Auto-Ranging Circuits
- Uses On-Chip System Clock or External Clock
- Wide Supply Range: e.g.,  $\pm 4.5V$  to  $\pm 8V$
- Available in Surface-Mount Packages

#### APPLICATIONS

- Portable Instruments
- Digital Voltmeters
- Digital Panel Meters
- Digital Scales
- Digital Thermometers
- Remote A/D Sensing Systems
- MPU Systems
- See Application Notes 19 and 21

#### GENERAL DESCRIPTION

The TC1433 is a low power, high-performance, monolithic CMOS 3-1/2 digit A/D converter. The TC14433 combines both analog and digital circuits on a single IC, thus minimizing the number of external components. This dual-slope A/D converter provides automatic polarity and zero correction with the addition of two external resistors and two capacitors. The full-scale voltage range of this ratiometric IC extends from 199.9 millivolts to 1.999 volts. The TC14433B can operate over a wide range of power supply voltages, including batteries and standard 5-volt supplies.

The TC14433 will interface with the TC7211A (LCD) and TC7212A (LED) display drivers.

The TC14433A/B feature improved performance over the industry standard TC14433. Rollover, which is the measurement of identical positive and negative signals, is guaranteed to have the same reading within one count for the TC14433A, and within four counts for the TC14433B. Power consumption of the TC14433A/B is typically 4 mW, approximately one-half that of the industry standard TC14433.

#### BLOCK DIAGRAM

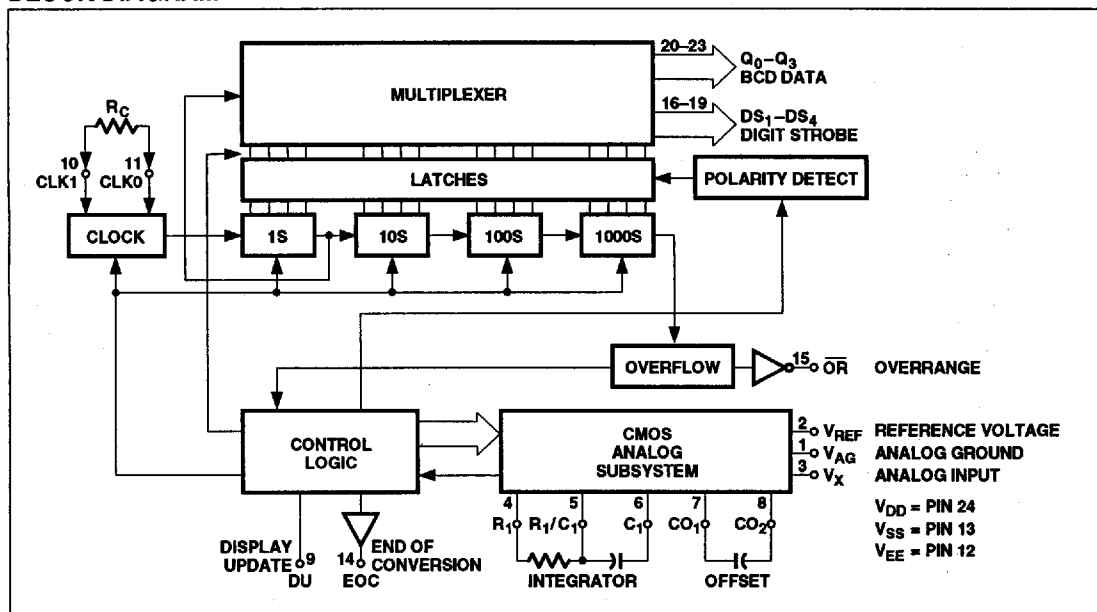

T-51-10-05

3-1/2 DIGIT ADC

**TC14433**  
**TC14433A**  
**TC14433B**

**ABSOLUTE MAXIMUM RATINGS**

Parameter	Symbol	Value	Unit
DC Supply Voltage	$V_{DD}$ to $V_{EE}$	-0.5 to +18	Vdc
Voltage, Any Pin, Referenced to $V_{EE}$	V	-0.5 to $V_{DD} + 0.5$	Vdc
DC Current Drain Per Pin	I	10	mAdc
Operating Temperature Range	$T_A$	-40 to +85	°C
Storage Temperature Range	$T_{STG}$	-65 to +150	°C

**RECOMMENDED OPERATING CONDITIONS** $(V_{SS} = 0 \text{ or } V_{EE})$ 

Parameter	Symbol	Value	Unit
DC Supply Voltage:			
$V_{DD}$ to Analog Ground	$V_{DD}$	+5 to +8	Vdc
$V_{EE}$ to Analog Ground	$V_{EE}$	-2.8 to -8	Vdc
Clock Frequency	$f_{CLK}$	32 to 400	kHz
Zero Offset Correction Capacitor	$C_O$	0.1 to $\pm 20\%$	$\mu F$

Static-sensitive device. Unused devices must be stored in conductive material. Protect devices from static discharge and static fields. Stresses above those listed under "Absolute Maximum Ratings" may cause permanent damage to the device. These are stress ratings only and functional operation of the device at these or any other conditions above those indicated in the operation sections of the specifications is not implied. Exposure to absolute maximum rating conditions for extended periods may affect device reliability.

**ELECTRICAL CHARACTERISTICS**

( $C_i = 0.1 \mu F$  mylar,  $R_i = 470 \text{ k}\Omega$  at  $V_{REF} = 2V$ ,  $R_i = 27 \text{ k}\Omega$  at  $V_{REF} = 200 \text{ mV}$ ,  $C_o = 0.1 \mu F$ ,  $R_c = 300 \text{ k}\Omega$ ; all voltages referenced to Analog Ground, pin 1.)

Characteristic	Symbol	$V_{DD}$		$V_{EE}$		-40°C		25°C			85°C		Unit
		Vdc	Vdc	Vdc	Vdc	Min	Max	Min	Typ	Max	Min	Max	
<b>Analog Input</b>													
Rollover Error (Difference in reading for equal positive and negative reading near full-scale)	14433A					-	-	-1	-	+1	-	-	Counts
	14433B					-	-	-4	-	+4	-	-	
$-V_{IN} = +V_{IN}$ ; 200 mV Full-Scale	14433					-	-	-	-	-	-	-	
Linearity Output Reading (Note 1)	—												%rdg
( $V_{REF} = 2V$ )		5	-5	-	-	-0.05	+0.05	+0.05	-	-	-	-	
( $V_{REF} = 200 \text{ mV}$ )		5	-5	-	-	-1 count	-	+1 count	-	-	-	-	
Stability Output Reading (Note 2)	—												LSD
( $V_x = 1.99V$ , $V_{REF} = 2V$ )		5	-5	-	-	-	-	2	-	-	-	-	
( $V_x = 199 \text{ mV}$ , $V_{REF} = 200 \text{ mV}$ )		5	-5	-	-	-	-	3	-	-	-	-	LSD
Zero Output Reading	—												LSD
( $V_x = 0V$ , $V_{REF} = 2V$ )		5	-5	-	-	-	0	0	-	-	-	-	
<b>Bias Current:</b>													
Analog Input	—	5	-5	-	-	-	-	$\pm 20$	$\pm 100$	-	-	-	pA
Reference Input	—	5	-5	-	-	-	-	$\pm 20$	$\pm 100$	-	-	-	pA
Analog Ground	—	5	-5	-	-	-	-	$\pm 20$	$\pm 500$	-	-	-	pA
Common-Mode Rejection	—												dB
( $V_x = 1.4V$ , $V_{REF} = 2V$ , $f_{oc} = 32 \text{ kHz}$ )		5	-5	-	-	-	-	65	-	-	-	-	
<b>Digital</b>													
<b>Output Voltage — Pins 14 to 23</b>													
( $V_{SS} = 0V$ )	"0" Level	$V_{OL}$	5	-5	-	0.05	-	0	0.05	-	0.05	-	V
	"1" Level	$V_{OH}$	5	-5	4.95	-	4.95	5	-	4.95	-	4.95	V
( $V_{SS} = -5V$ )	"0" Level	$V_{OL}$	5	-5	-	-4.95	-	-5	-4.95	-	-4.95	-	V
	"1" Level	$V_{OH}$	5	-5	4.95	-	4.95	5	-	4.95	-	4.95	V

T-51-10-05

## 3-1/2 DIGIT ADC

**TC144333**  
**TC14433A**  
**TC14433B**

1

Characteristic	Symbol	V <sub>DD</sub>	V <sub>EE</sub>	-40°C		25°C			85°C		Unit
		Vdc	Vdc	Min	Max	Min	Typ	Max	Min	Max	
Output Current — Pins 14 to 23 (V <sub>SS</sub> = 0V)											
(V <sub>OH</sub> = 4.6V) Source	I <sub>OH</sub>	5	-5	-0.25	—	-0.2	-0.36	—	-0.14	—	mA
(V <sub>OL</sub> = 0.4V) Sink	I <sub>OL</sub>	5	-5	0.64	—	0.51	0.88	—	0.36	—	mA
(V <sub>SS</sub> = 0V)											
(V <sub>OH</sub> = 5V) Source	I <sub>OH</sub>	5	-5	-0.62	—	-0.5	-0.9	—	-0.35	—	mA
(V <sub>OL</sub> = -4.5V) Sink	I <sub>OL</sub>	5	-5	1.6	—	1.3	2.25	—	0.9	—	mA
Clock Frequency (R <sub>C</sub> = 300 kΩ)	f <sub>CLK</sub>	5	-5	—	—	—	66	—	—	—	kHz
Input Current — DU	I <sub>DU</sub>	5	-5	—	±0.3	—	±0.00001	±0.3	—	±1	μA
<b>Power</b>											
Quiescent Current		5	-5	—	3.7	—	0.4	2	—	1.6	mA
(V <sub>DD</sub> to V <sub>EE</sub> , I <sub>SS</sub> = 0) 14433A/B	I <sub>Q</sub>	8	-8	—	7.4	—	1.4	4	—	3.2	mA
14433	I <sub>Q</sub>	5	-5	—	3.7	—	0.9	2	—	1.6	mA
		8	-8	—	7.4	—	1.8	4	—	3.2	mA
Supply Rejection											
(V <sub>DD</sub> to V <sub>EE</sub> , I <sub>SS</sub> = 0, V <sub>REF</sub> = 2V)	—	5	-5	—	—	—	0.5	—	—	—	mV/V

- NOTES:** 1. Accuracy — The accuracy of the meter at full-scale is the accuracy of the setting of the reference voltage. Zero is recalculated during each conversion cycle. The meaningful specification is linearity. In other words, the deviation from correct reading for all inputs other than positive full-scale and zero is defined as the linearity specification.
2. Three LSD stability for 200 mV scale is defined as the range that the LSD will occupy 95% of the time.
3. Pin numbers refer to 24-pin DIP.

## ORDERING INFORMATION

Part No.	Package	Temperature Range
TC14433AEPG	24-Pin Plastic DIP	-40°C to +85°C
TC14433BEPG		
TC14433EPG		
TC14433EJG	24-Pin CerDIP	-40°C to +85°C
TC14433EJG		
TC14433EJG		
TC14433ELI	28-Pin PLCC	-40°C to +85°C
TC14433AELI		

Part No.	Package	Temperature Range
TC14433EBQ	60-Pin Plastic Flat Package: Formed Leads	-40°C to +85°C
TC14433EBQ		

TC14433  
TC14433A  
TC14433B

TYPICAL CHARACTERISTICS

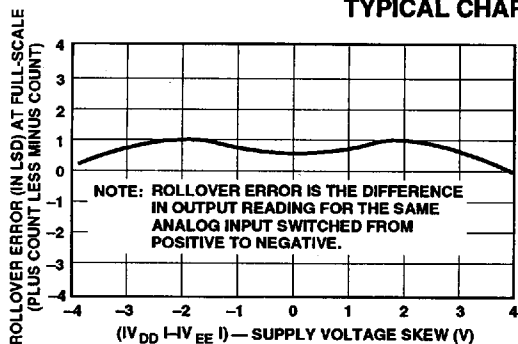

Figure 1. Typical Rollover Error vs Power Supply Skew

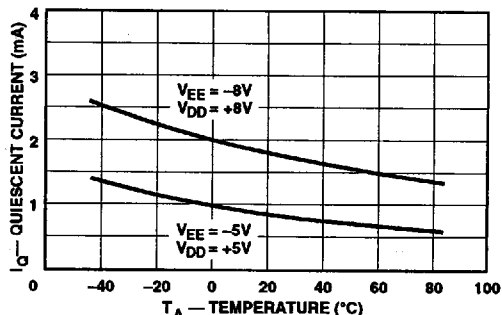

Figure 2. Typical Quiescent Power Supply Current vs Temperature

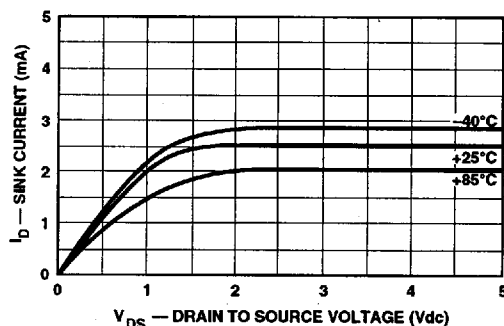

Figure 3. Typical N-Channel Sink Current at  $V_{DD} - V_{SS} = 5$  Volts

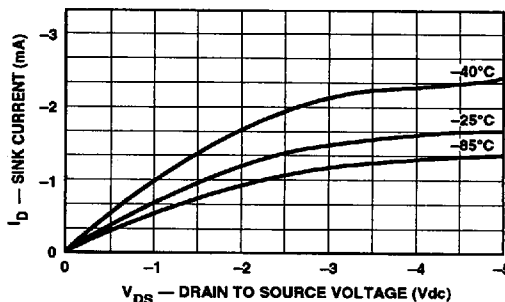

Figure 4. Typical P-Channel Source Current at  $V_{DD} - V_{SS} = 5$  Volts

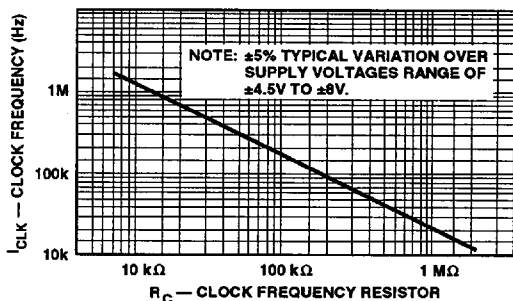

Figure 5. Typical Clock Frequency vs Resistor ( $R_C$ )

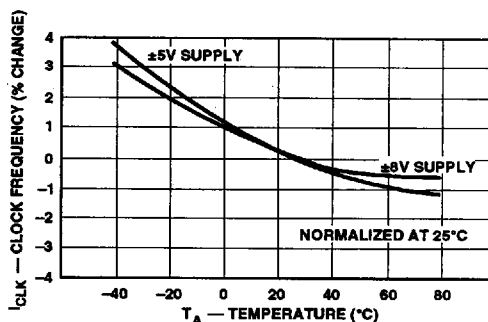

Figure 6. Typical % Change of Clock Frequency vs Temperature

CONVERSION RATE = $\frac{\text{CLOCK FREQUENCY}}{16,400} \pm 1.5\%$
MULTIPLEX RATE = $\frac{\text{CLOCK FREQUENCY}}{80}$

3-1/2 DIGIT ADC

T-51-10-05

TC14433  
TC14433A  
TC14433B

1

PIN CONFIGURATIONS

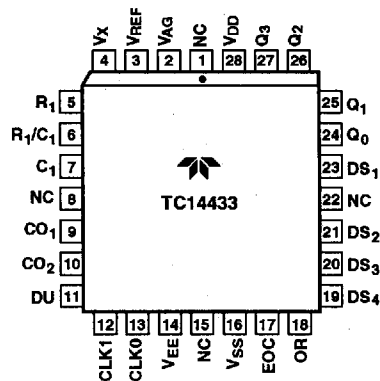
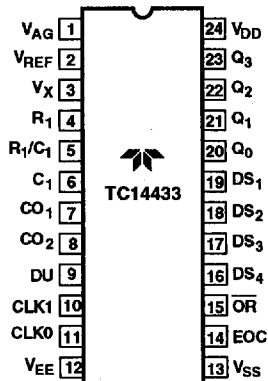

$$R_1 = \frac{V_X(\max)}{C_1} \cdot 3 \cdot \frac{T}{\Delta V}$$

$$\Delta V = V_{DD} - V_X(\max) - 0.5$$

$$T = 4000 \cdot 3 \cdot \frac{1}{f_{CLK}}$$

WHERE:  
R<sub>1</sub> IS IN kΩ  
V<sub>DD</sub> IS THE VOLTAGE AT PIN 24 REFERENCED TO V<sub>AG</sub>  
V<sub>X</sub> IS THE VOLTAGE AT PIN 3 REFERENCED TO V<sub>AG</sub>  
f<sub>CLK</sub> IS THE CLOCK FREQUENCY AT PIN 10 IN kHz

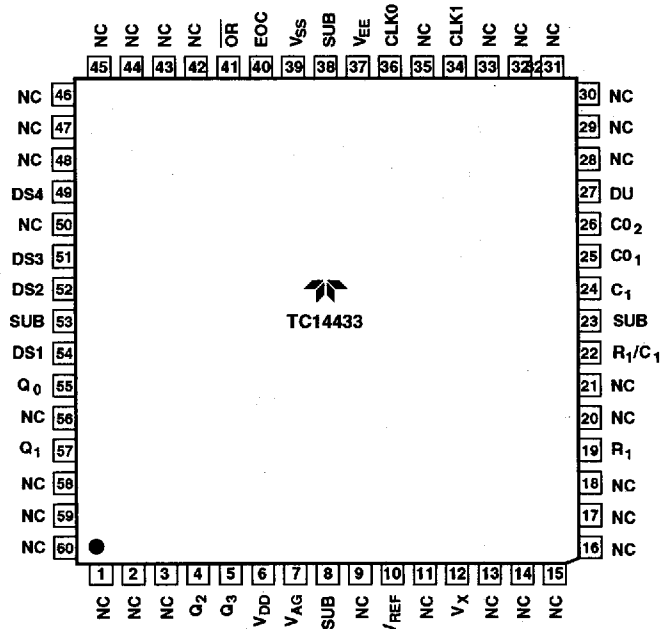

- NOTES:  
1. NC = NO INTERNAL CONNECTION  
2. PINS 8, 23, 38 AND 53 ARE CONNECTED TO THE DIE SUBSTRATE.  
THE POTENTIAL AT THESE PINS IS APPROXIMATELY V<sup>+</sup>. NO EXTERNAL CONNECTIONS SHOULD BE MADE.

TC14433  
TC14433A  
TC14433B

## PIN DESCRIPTIONS

Pin No. 60-Pin FP	Pin No. 24-Pin DIP	Symbol	Description
7	1	$V_{AG}$	This is the analog ground; it has a high input impedance — This pin determines the reference level for the unknown input voltage ( $V_x$ ) and the reference voltage ( $V_{REF}$ ).
10	2	$V_{REF}$	Reference voltage — Full-scale output is equal to the voltage applied to $V_{REF}$ . Therefore, full-scale voltage of 1.999V requires 2V reference and 199.9 mV full-scale requires a 200 mV reference. $V_{REF}$ functions as system reset also. When switched to $V_{EE}$ , the system is reset to the beginning of the conversion cycle.
12	3	$V_x$	The unknown input voltage ( $V_x$ ) is measured as a ratio of the reference voltage ( $V_{REF}$ ) in a ratiometric A/D conversion.
19	4	$R_1$	These pins are for external components used for the integration function in the dual slope conversion. Typical values are 0.1 $\mu$ F (mylar) capacitor for $C_1$ . $R_1 = 470$ k $\Omega$ (resistor) for 2V full-scale. $R_1 = 27$ k $\Omega$ (resistor) for 200 mV full-scale. Clock frequency of 66 kHz gives 250 ms conversion time. See equation below for calculation of integrator component values.
22	5	$R_1/C_1$	
24	6	$C_1$	
25	7	$CO_1$	These pins are used for connecting the offset correction capacitor. The recommended value is 0.1 $\mu$ F.
26	8	$CO_2$	
27	9	DU	Display update input pin — When DU is connected to the EOC output every conversion is displayed. New data will be strobed into the output latches during the conversion cycle if a positive edge is received on DU prior to the ramp-down cycle. When this pin is driven from an external source, the voltage should be referenced to $V_{SS}$ .
34	10	$CLK_1$	Clock input pins — The TC14433 has its own oscillator system clock. Connecting a single resistor between $CLK_1$ and $CLK_0$ sets the clock frequency. A crystal or OC circuit may be inserted in lieu of a resistor for improved stability. $CLK_1$ , the clock input, can be driven from an external clock source, which need only have standard CMOS output drive. This pin is referenced to $V_{EE}$ for external clock inputs. A 300 k $\Omega$ resistor yields a clock frequency of about 66 kHz. (See typical characteristic curves; see Figure 9 for alternate circuits.)
36	11	$CLK_0$	
37	12	$V_{EE}$	Negative power current — Connection pin for the most negative supply. Please note the current for the output drive circuit is returned through $V_{SS}$ . Typical supply current is 0.8 mA.
39	13	$V_{SS}$	Negative power supply for output circuitry — This pin sets the low voltage level for the output pins (BCD, Digit Selects, EOC, OR). When connected to analog ground, the output voltage is from analog ground to $V_{DD}$ . If connected to $V_{EE}$ , the output swing is from $V_{EE}$ to $V_{DD}$ . The recommended operating range for $V_{SS}$ is between the $V_{DD} - 3$ volts and $V_{EE}$ .
40	14	EOC	End of conversion output generates a pulse at the end of each conversion cycle. This generated pulse width is equal to one-half the period of the system clock.
41	15	OR	Overrange pin — Normally this pin is set high. When $V_x$ exceeds $V_{REF}$ the OR pin is low.
49	16	$DS_4$	Digit select pins — The digit select output goes high when the respective digit is selected. The MSD (1/2 digit) turns on immediately after an EOC pulse. The remaining digits turn on in sequence from MSD to LSD. To ensure that the BCD data has settled, an inter-digit blanking time of two clock periods is included.
51	17	$DS_3$	
52	18	$DS_2$	Clock frequency divided by 80 equals multiplex rate. For example, a system clock of 60 kHz gives a multiplex rate of 0.8 kHz.
54	19	$DS_1$	
5	20	$Q_0$	See Figure 12 for digit select timing diagram. BCD data output pins — Multiplexed BCD outputs contain three full digits of information during digit select $DS_2$ , $DS_3$ , $DS_4$ .
4	21	$Q_1$	
57	22	$Q_2$	During $DS_1$ , the 1/2 digit, overrange, underrange and polarity information is available. Refer to truth table.
55	23	$Q_3$	
6	24	$V_{DD}$	Positive power supply — This is the most positive power supply pin.

T-51-10-05

## 3-1/2 DIGIT ADC

TC14433  
TC14433A  
TC14433B

1

## CIRCUIT DESCRIPTION

The TC14433 CMOS IC becomes a modified dual-slope A/D with a minimum of external components. This IC has the customary CMOS digital logic circuitry, as well as CMOS analog circuitry. It provides the user with digital functions (such as counters, latches, multiplexers) and analog functions (such as operational amplifiers and comparators) on a single chip.

Features of this system include auto-zero, high input impedances and auto-polarity. Low power consumption and a wide range of power supply voltages are also advantages of this CMOS device. The system's auto-zero function compensates for the offset voltage of the internal amplifiers and comparators. In this "ratiometric system," the output reading is the ratio of the unknown voltage to the reference voltage, where a ratio of 1 is equal to the maximum count of 1999. It takes approximately 16,000 clock periods to complete one conversion cycle. Each conversion cycle may be divided into 6 segments. Figure 7 shows the conversion cycle in 6 segments for both positive and negative inputs.

**Segment 1** — The offset capacitor ( $C_o$ ), which compensates for the input offset voltages of the buffer and integrator amplifiers, is charged during this period. However, the integrator capacitor is shorted. This segment requires 4000 clock periods.

**Segment 2** — During this segment, the integrator output decreases to the comparator threshold voltage. At this time, a number of counts equivalent to the input offset voltage of the comparator is stored in the offset latches for later use in the auto-zero process. The time for this segment is variable and less than 800 clock periods.

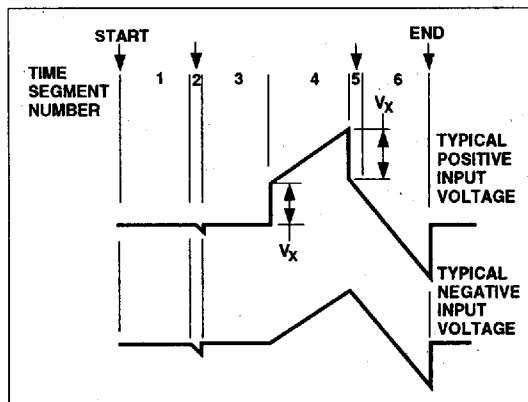

Figure 7. Integrator Waveforms at Pin 6

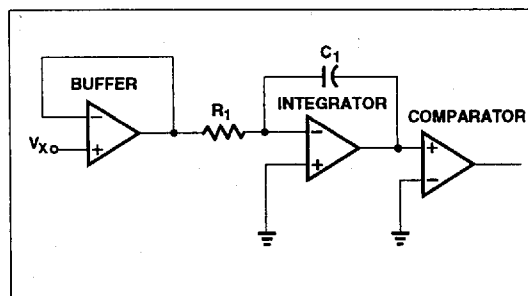

Figure 8. Equivalent Circuit Diagrams of the Analog Section During Segment 4 of the Timing Cycle

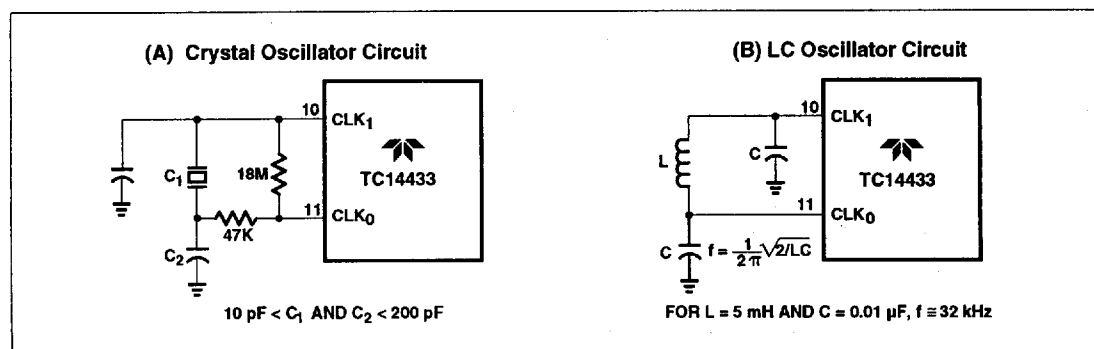

Figure 9. Alternate Oscillator Circuits

**TC14433**  
**TC14433A**  
**TC14433B**

**Segment 3** — This segment of the conversion cycle is the same as Segment 1.

**Segment 4** — Segment 4 is an up-going ramp cycle with the unknown input voltage ( $V_x$ ) as the input to the integrator. Figure 8 shows the equivalent configuration of the analog section of the TC14433. The actual configuration of the analog section is dependent upon the polarity of the input voltage during the previous conversion cycle.

**Segment 5** — This segment is a down-going ramp

period with the reference voltage as the input to the integrator. Segment 5 of the conversion cycle has a time equal to the number of counts stored in the offset storage latches during Segment 2. As a result, the system zeros automatically.

**Segment 6** — This is an extension of Segment 5. The time period for this portion is 4000 clock periods. The results of the A/D conversion cycle are determined in this portion of the conversion cycle.

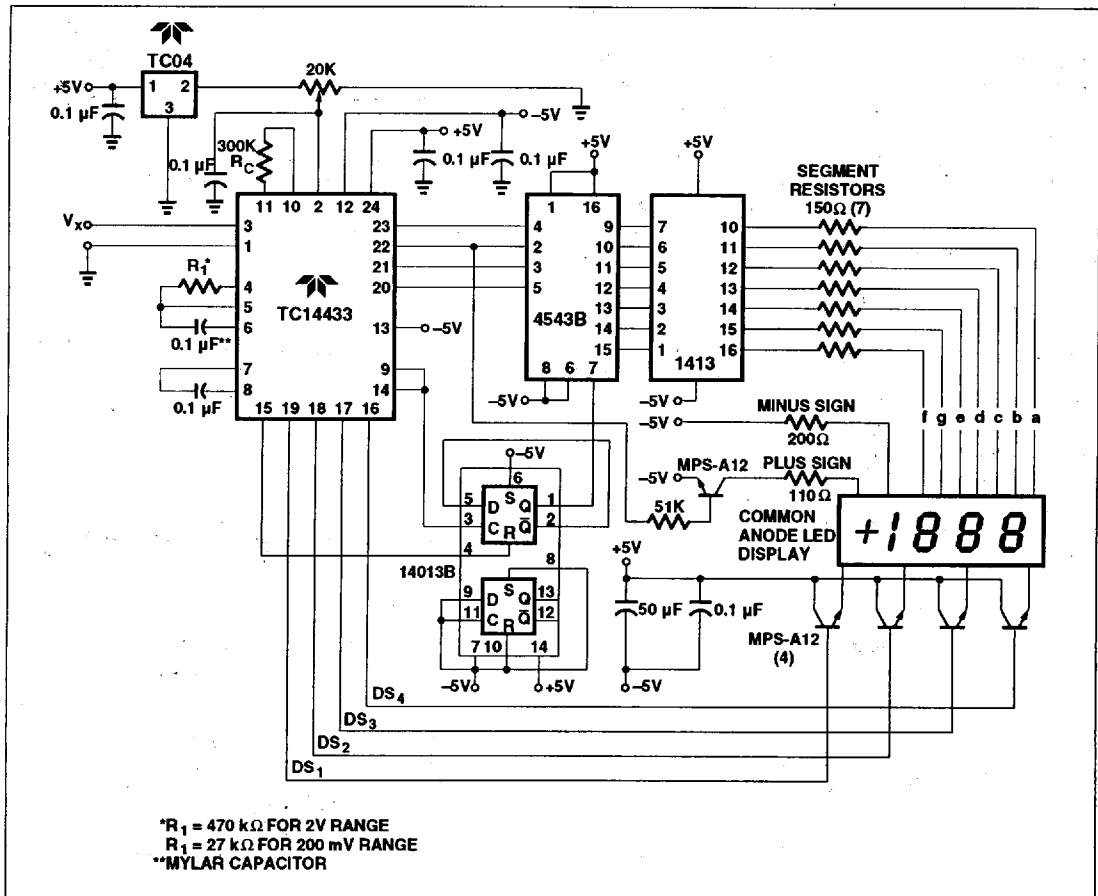

Figure 10. 3-1/2 Digit Voltmeter Common-Anode Displays, Flashing Overrange

T-51-10-05

3-1/2 DIGIT ADC

TC14433  
TC14433A  
TC14433B

1

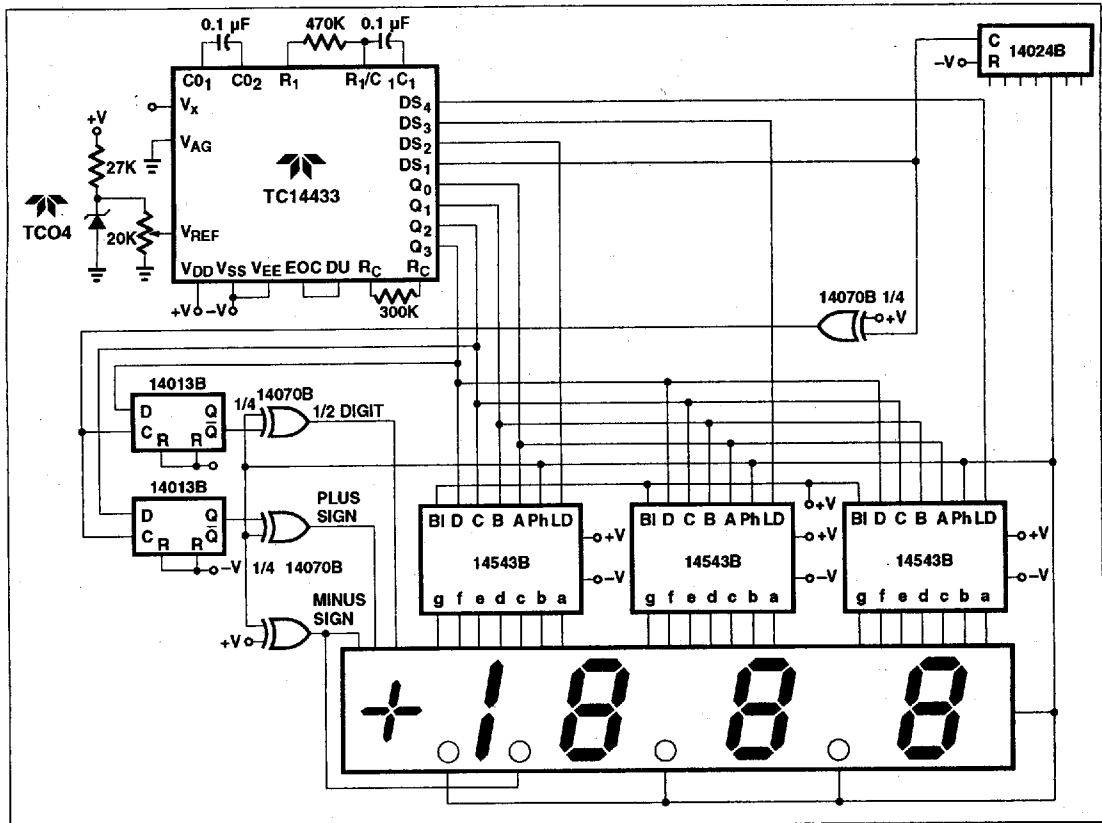

Figure 11. 3-1/2 Digit Voltmeter with LCD Display

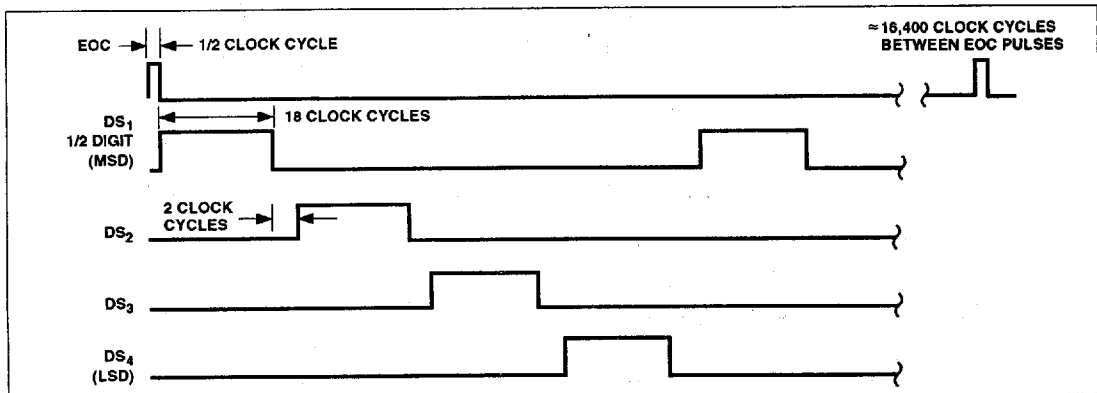

Figure 12. Digit Select Timing Diagram

**TC14433**  
**TC14433A**  
**TC14433B**

**APPLICATIONS INFORMATION**

Figure 10 is an example of a 3-1/2 digit voltmeter using the TC14433 with common-anode displays. This system requires a 2.5V reference. Full-scale may be adjusted to 1.999V or 199.9 mV. Input overrange is indicated by flashing a display. This display uses LEDs with common anode digit lines. Power supply for this system is shown as a dual  $\pm 5V$  supply; however, the TC14433 will operate over a wide voltage range (see recommended operating conditions, page 2).

The circuit in Figure 11 shows a 3-1/2 digit LCD voltmeter. The 14024B provides the low frequency square wave signal drive to the LCD backplane. Dual power supplies are shown here; however, one supply may be used when  $V_{SS}$  is connected to  $V_{EE}$ . In this case,  $V_{AG}$  must be at least 2.8V above  $V_{EE}$ .

When only segments b and c of the decoder are connected to the 1/2 digit of the display, 4, 0, 7 and 3 appear as 1.

The overrange indication ( $Q_3 = 0$  and  $Q_0 = 1$ ) occurs when the count is greater than 1999; e.g., 1.999V for a reference of 2V. The underrange indication, useful for auto-ranging circuits, occurs when the count is less than 180; e.g., 0.180V for a reference of 2V.

**CAUTION**

If the most significant digit is connected to a display other than a "1" only, such as a full digit display, segments other than b and c must be disconnected. The BCD to 7-segment decoder must blank on BCD inputs 1010 to 1111.

Figure 14 is an example of a 3-1/2 digit LED voltmeter with a minimum of external components (only 11 additional components). In this circuit, the 14511B provides the segment drive and the 75492 or 1413 provides sink for digit current. Display is blanked during the overrange condition.

**TRUTH TABLE**

Coded Condition of MSD	$Q_3$	$Q_2$	$Q_1$	$Q_0$	BCD to 7-Segment Decoding
+0	1	1	1	0	Blank
-0	1	0	1	0	Blank
+0 UR	1	1	1	1	Blank
-0 UR	1	0	1	1	Blank
+1	0	1	0	0	4-1 } Hook up
-1	0	0	0	0	0-1 } only
+1 OR	0	1	1	1	7-1 } segments
-0 OR	0	0	1	1	3-1 } b and c to MSD

**NOTES:**

- $Q_3$  — 1/2 digit, low for "1", high for "0"
- $Q_2$  — Polarity: "1" = positive, "0" = negative
- $Q_0$  — Out of range condition exists if  $Q_0 = 1$ . When used in conjunction with  $Q_3$ , the type of out of range condition is indicated; i.e.,  $Q_3 = 0 \rightarrow$  OR or  $Q_3 = 1 \rightarrow$  UR.

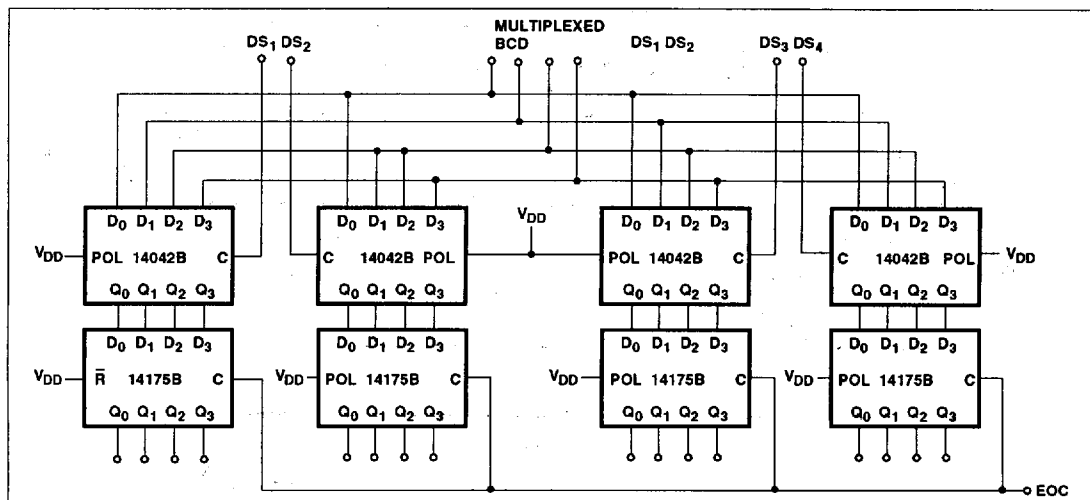

Figure 13. Demultiplexing for TC14433 BCD Data

3-1/2 Digit ADC

TC14433  
TC14433A  
TC14433B

1

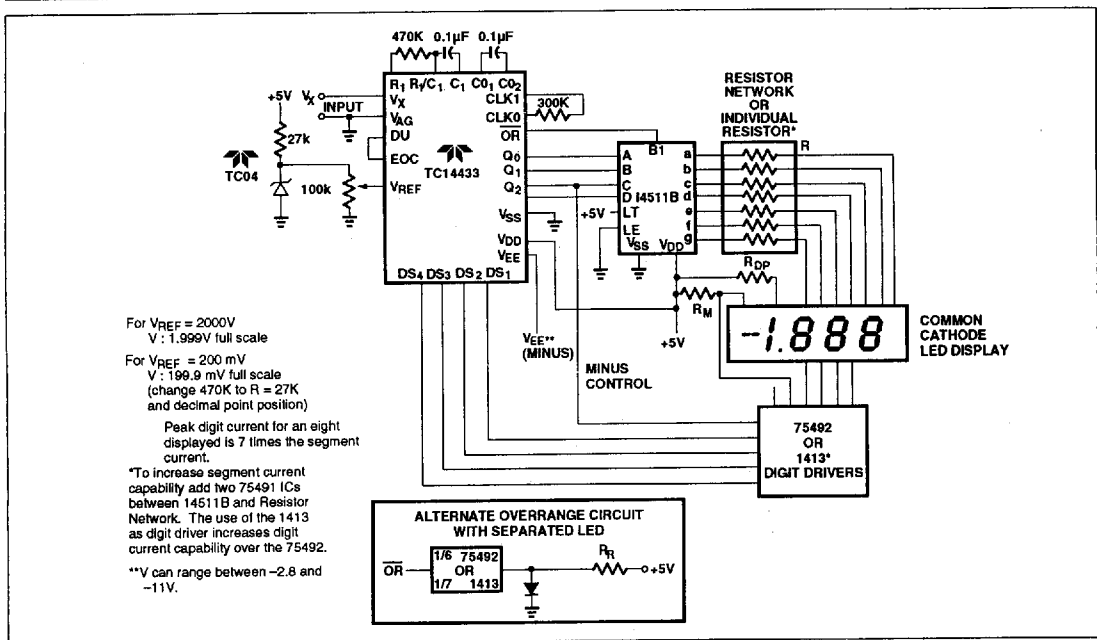

Figure 14. 3-1/2 Digit Voltmeter with Low Component Count Using Common Cathode Displays

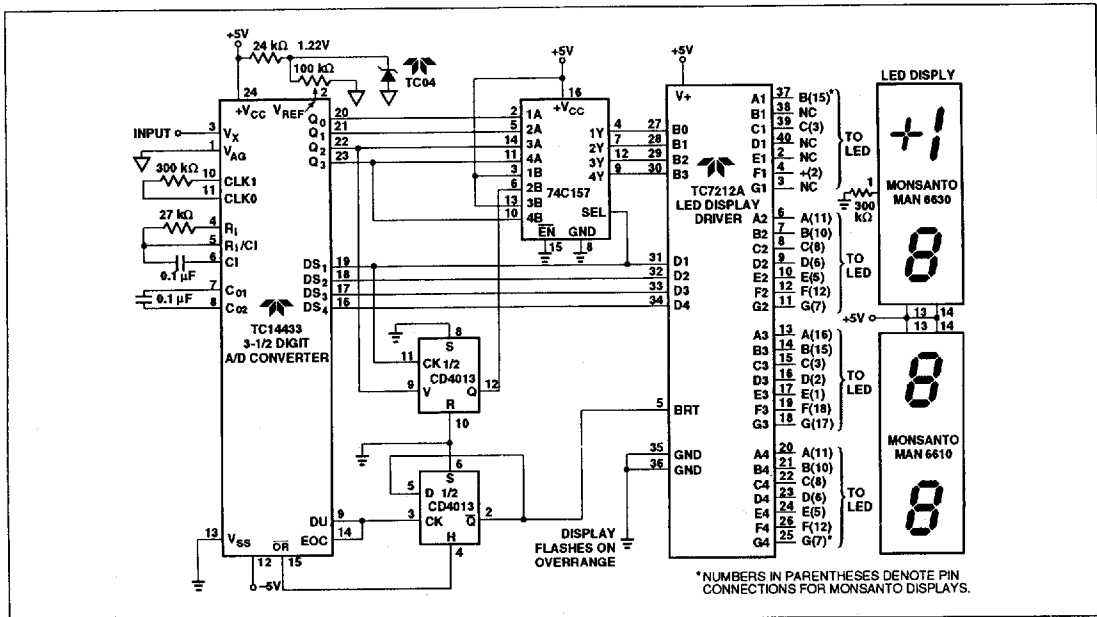

Figure 15. TC7212A Interface to TC14433 3-1/2 Digit ADC