

REVISIONS		
ISS	ZONE	DESCRIPTION\PER REQUEST\DATE

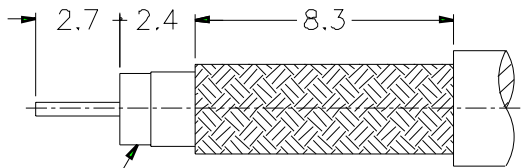

REMOVE FOIL 1mm MIN.
RECOMMENDED CABLE STRIPPING DIM'S

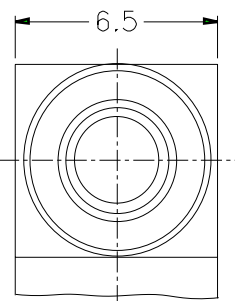

C VIEW

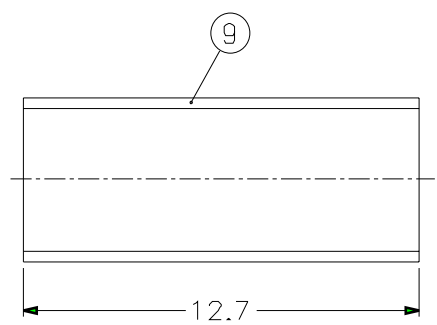
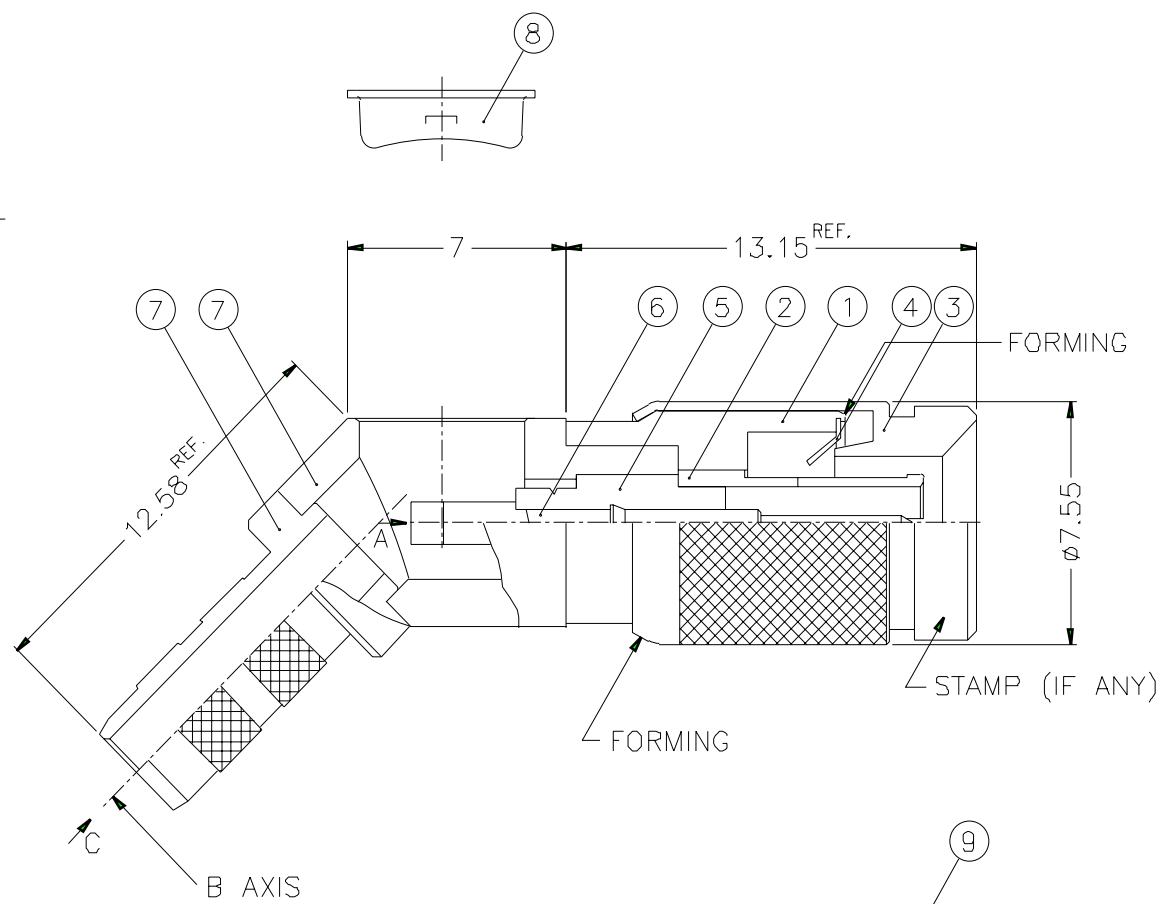
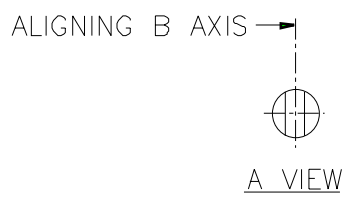

- FERRULE CRIMPING TOOLS P/N
227-944 (M22520/5-01)
227-1221-19B (M22520/5-19B) HEX: 4.52
- INNER CONTACT TO SOLDER

9	FERRULE	COPPER	NICKEL	1	FR-51/445X127
8	COVER	BRASS	NICKEL	1	4G-731-01
7	HOUSING WITH BARREL	BRASS	NICKEL	1	
6	CONTACT PIN	BRASS	GOLD	1	4J-556-03-75
5	INSULATOR	PTFE	NATURAL	1	4G-727-04-75
4	SPRING	BECU	NATURAL	1	123-PLUG-SPR
3	SHELL	BRASS	NICKEL	1	SH10AAC01A
2	OUT CONTACT	BECU	GOLD	1	4G-980-01
1	BODY	BRASS	NICKEL	1	BD00AGD01A
NO.	DESCRIPTION	MATERIAL	FINISH	Q'TY	DRAWING NO.

DIMENSIONS ARE IN MILLIMETERS
UNLESS OTHERWISE SPECIFIED TOLERANCES
0.5-6 = ±0.2
6-30 = ±0.4
30-120 = ±0.6
120-315 = ±1
315-1000 = ±1.6
1000-2000 = ±2.4

PART NO.	1231110L2-E16	
APPROVED	DATE	08-09-02'
CHECKED	DATE	08-09-02'
DRAWN	DATE	08-09-02'
FILE NO.	F:\ND\10\1110\ERA\37\7F\MN	

Amphenol RF	
TITLE	1.0/2.3 R/A 45° CRIMP PLUG (FOR FLEX-3/75 CABLE)
DRAWING NO.	101110ERA37MN7F
ITEM NO.	101110ERA37MN7F