

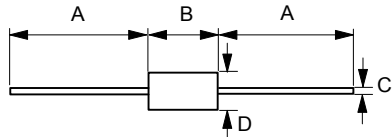

<p>Sidac High Voltage Silicon Bidirectional Thyristors</p>	<p>SIDACS 0.9 AMPERES RMS 120 thru 240 VOLTS</p>																		
<p>FEATURES</p> <ul style="list-style-type: none"> • High Pressure Sodium Vapor Lighting • Strobes and Flashers • Igniters • High Voltage Regulators • Pulse Generators • Used to Trigger Gates of SCR's and Triacs 	<p>DO-41</p>  <table border="1" style="margin: 10px auto;"> <thead> <tr> <th colspan="3">DO-41</th> </tr> <tr> <th>Dim.</th> <th>Min.</th> <th>Max.</th> </tr> </thead> <tbody> <tr> <td>A</td> <td>25.4</td> <td>-</td> </tr> <tr> <td>B</td> <td>4.10</td> <td>5.20</td> </tr> <tr> <td>C</td> <td>0.71 ϕ</td> <td>0.86 ϕ</td> </tr> <tr> <td>D</td> <td>2.00 ϕ</td> <td>2.70 ϕ</td> </tr> </tbody> </table> <p style="text-align: center; font-size: small;">All Dimensions in millimeter</p> 	DO-41			Dim.	Min.	Max.	A	25.4	-	B	4.10	5.20	C	0.71 ϕ	0.86 ϕ	D	2.00 ϕ	2.70 ϕ
DO-41																			
Dim.	Min.	Max.																	
A	25.4	-																	
B	4.10	5.20																	
C	0.71 ϕ	0.86 ϕ																	
D	2.00 ϕ	2.70 ϕ																	

MAXIMUM RATINGS (T_j= 25 unless otherwise noticed)

Rating	Symbol	Value	Unit
Peak Repetitive Off- State Voltage (T _J = -40 to 125 , Sine Wave, 50 to 60 Hz)	SDC1V120, SDC1A130, SDC1A160 SDC1A240	V _{DRM} , V _R RRM	± 90 ± 180 Volts
On-State RMS Current (T _L = 80 , Lead Lengh=3/8" , All Conduction Angles)	I _{T(RMS)}	± 0.9	Amp
Peak Non-Repetitive Surge Current 60 Hz One Cycle Sine Wave (T _j = 125)	I _{TSM}	± 4.0	Amps
Operating Junction Temperature Range	T _J	-40 to +125	
Storage Temperature Range	T _{stg}	-40 to +150	

Maximum ratings are those values beyond which device damage can occur. Maximum ratings applied to the device are individual stress limit values (not normal operating conditions) and are not valid simultaneously. If these limits are exceeded, device functional operation is not implied, damage may occur and reliability may be affected.

REV. 0, Nov-2004, KDXC01

THERMAL CHARACTERISTICS

Characteristic	Symbol	Value	Unit
Thermal Resistance - Junction to Lead Lead Length = 3/8 "	RthJL	40	/W
Maximum Lead Solder Temperature (Lead Length 1/16 " from Case, 10s Max)	TL	260	

ELECTRICAL CHARACTERISTICS (T_c=25 unless otherwise noted)

Characteristics	Symbol	Min	Typ	Max	Unit
-----------------	--------	-----	-----	-----	------

OFF CHARACTERISTICS

Peak Reptitive Forward or Reverse Blocking Current (50 to 60 Hz Sine Wave) V _{DRM} =90V, SDC1A120, SDC1A130, SDC1A160 V _{DRM} =180V, SDC1A240	I _{DRM}	---	---	5	uA
--	------------------	-----	-----	---	----

ON CHARACTERISTICS

Peak On-State Voltage (I _{TM} =1A Peak @T _p 300 us, Duty Cycle 2%)	V _{TM}	---	1.3	1.5	Volts
Breakover Voltage I _{BO} = 35uA SDC1A120 35uA SDC1A130 200uA SDC1A160 35uA SDC1A240	V _{BO}	110 120 150 220	--- --- --- ---	130 140 170 250	Volts
Dynamic Holding Current (Sine Wave, 50 to 60 Hz, R _L =100 Ohm)	I _H	---	---	100	mA
Switching Resistance (Sine Wave, 50 to 60 Hz)	R _s	0.1	---	---	kO

DYNAMIC CHARACTERISTICS

Critical Rate of Rise of On-State Current, Critical Damped Waveform Circuit (I _{PK} = 130 A, Pulse Width = 10 us)	di/dt	---	120	---	A/us
--	-------	-----	-----	-----	------

**Voltage Current Characteristic of SIDAC
(Bidirectional Device)**

Symbol	Parameter
I_{DRM}	Off State Leakage Current
V_{DRM}	Off State Repetitive Blocking Voltage
V_{BO}	Breakover Voltage
I_{BO}	Breakover Current
I_H	Holding Current
V_{TM}	On State Voltage
I_{TM}	Peak on State Current

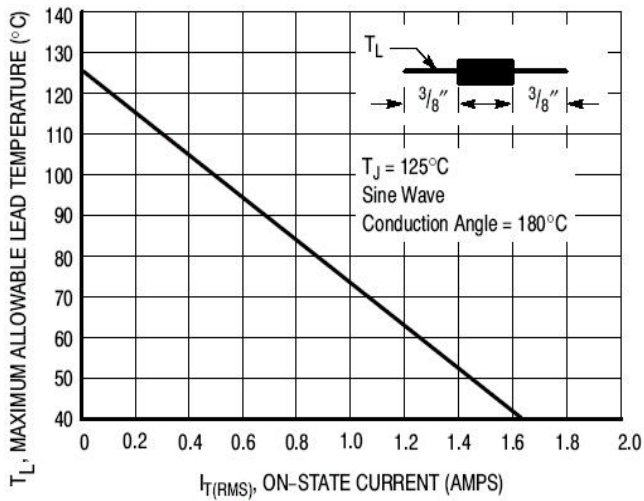
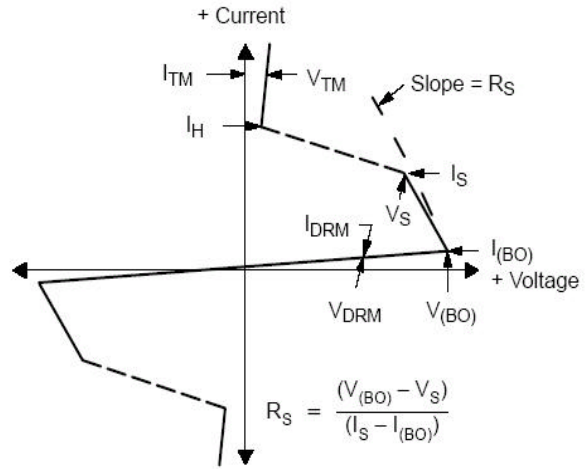

Figure 1. Maximum Lead Temperature

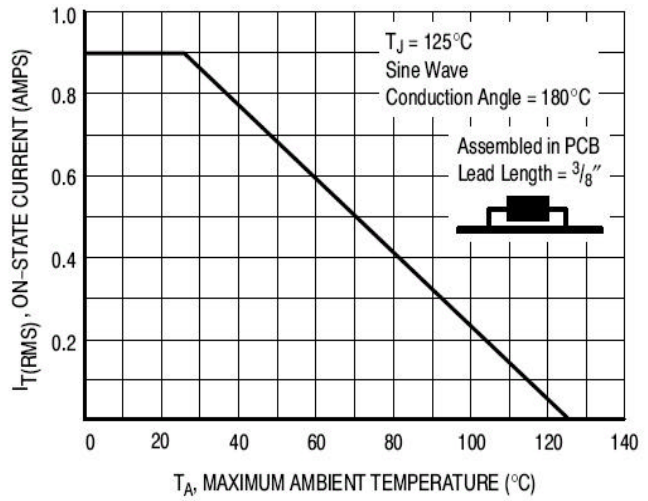

Figure 2. Maximum Ambient Temperature

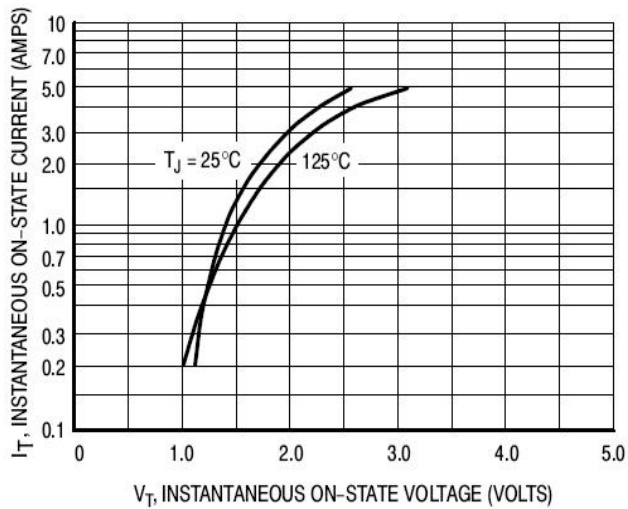

Figure 3. Typical On-State Voltage

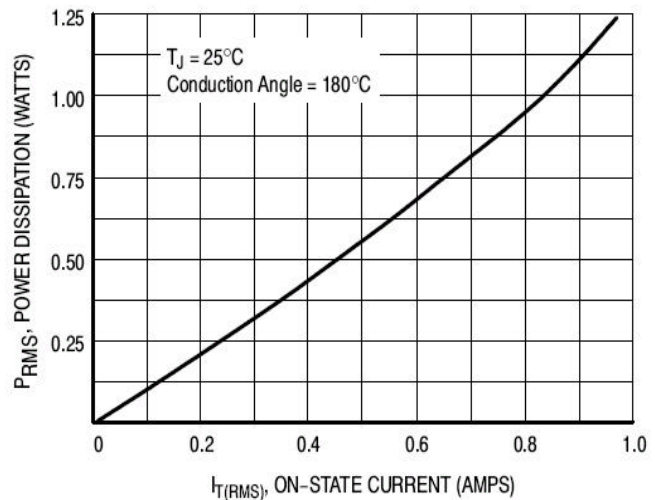

Figure 4. Typical Power Dissipation

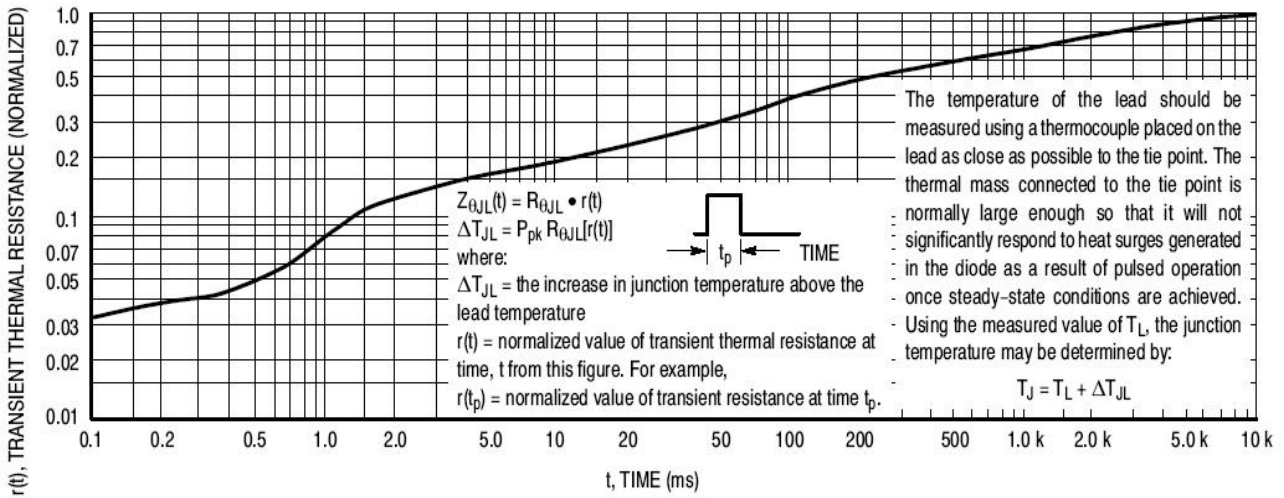

Figure 5. Thermal Response

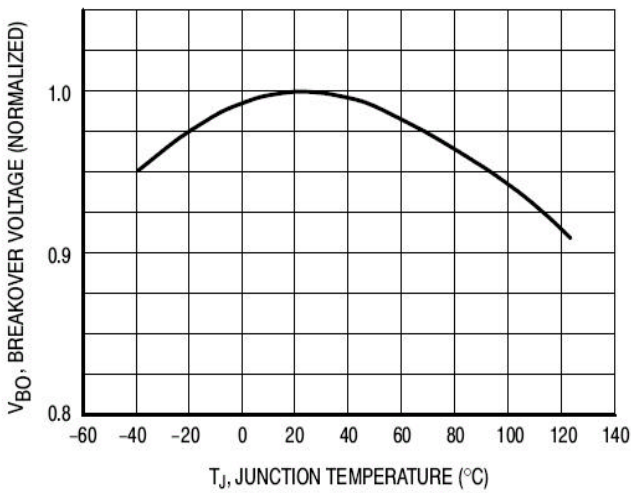

Figure 6. Typical Breakover Voltage

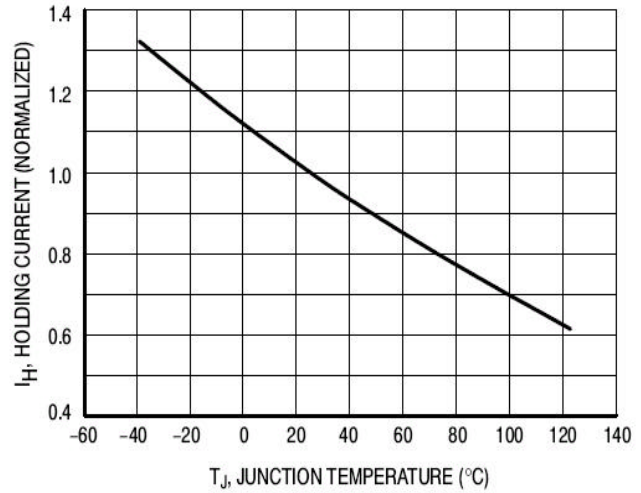

Figure 7. Typical Holding Current

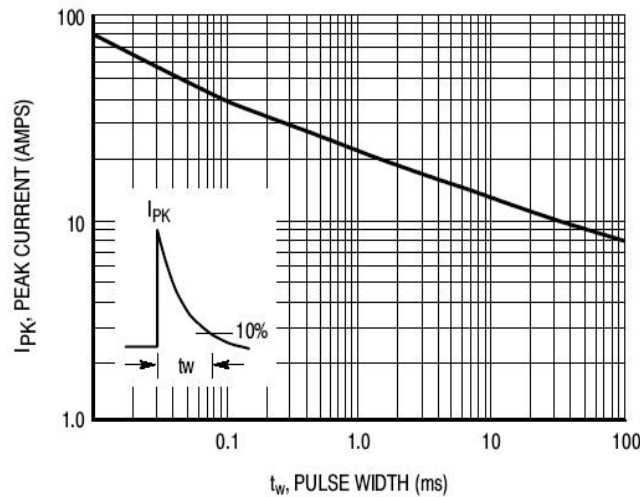

Figure 8. Pulse Rating Curve