



4-BIT ARITHMETIC LOGIC UNIT

The MC54/74F381 performs three arithmetic and three logic operations on two 4-bit words, A and B. Two additional Select input codes force the Function outputs LOW or HIGH. Carry Propagate and Generate outputs are provided for use with the F182 Carry Lookahead Generator for high-speed expansion to longer word lengths. For ripple expansion, refer to the F382 ALU data sheet.

- Low Input Loading Minimizes Drive Requirements
- Performs Six Arithmetic and Logic Functions
- Selectable Low (Clear) and High (Preset) Functions
- Carry Generate and Propagate Outputs for use with Carry Lookahead Generator

CONNECTION DIAGRAM

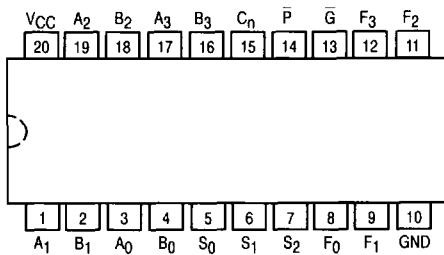

LOGIC SYMBOL

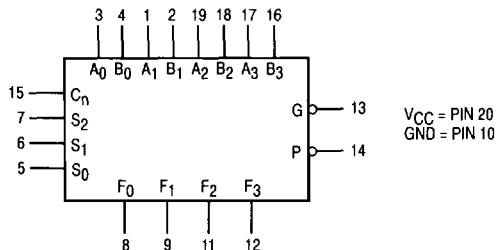

MC54/74F381

4-BIT ARITHMETIC LOGIC UNIT

FAST™ SCHOTTKY TTL

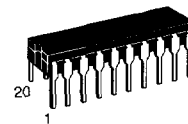

J SUFFIX
CERAMIC
CASE 732-03

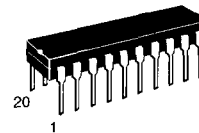

N SUFFIX
PLASTIC
CASE 738-03

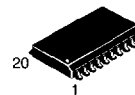

DW SUFFIX
SOIC
CASE 751D-03

ORDERING INFORMATION

MC54FXXXJ Ceramic
MC74FXXXN Plastic
MC74FXXXDW SOIC

GUARANTEED OPERATING RANGES

Symbol	Parameter		Min	Typ	Max	Unit
VCC	Supply Voltage	54, 74	4.5	5.0	5.5	V
TA	Operating Ambient Temperature Range	54	-55	25	125	°C
		74	0	25	70	
I _{OH}	Output Current — High	54, 74			-1.0	mA
I _{OL}	Output Current — Low	54, 74			20	mA

MC54/74F381

LOGIC DIAGRAM

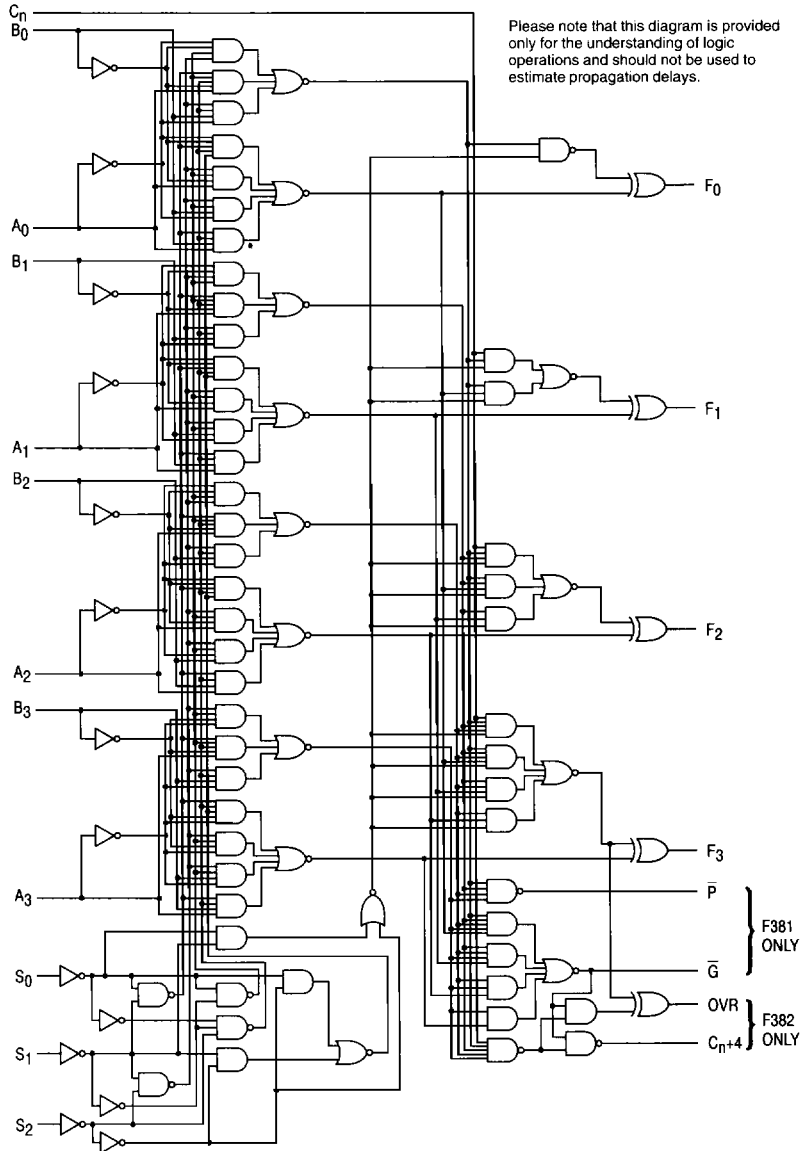

MC54/74F381

DC CHARACTERISTICS OVER OPERATING TEMPERATURE RANGE (unless otherwise specified)

Symbol	Parameter	Limits			Unit	Test Conditions	
		Min	Typ	Max			
V_{IH}	Input HIGH Voltage	2.0			V	Guaranteed Input HIGH Voltage	
V_{IL}	Input LOW Voltage			0.8	V	Guaranteed Input LOW Voltage	
V_{IK}	Input Clamp Diode Voltage			-1.2	V	$I_{IN} = -18 \text{ mA}$	$V_{CC} = \text{MIN}$
V_{OH}	Output HIGH Voltage	54, 74	2.5	3.4	V	$I_{OH} = -1.0 \text{ mA}$	$V_{CC} = 4.5 \text{ V}$
		74	2.7	3.4	V	$I_{OH} = -1.0 \text{ mA}$	$V_{CC} = 4.75 \text{ V}$
V_{OL}	Output LOW Voltage		0.35	0.5	V	$I_{OL} = 20 \text{ mA}$	$V_{CC} = \text{MIN}$
I_{IH}	Input HIGH Current			20	μA	$V_{IN} = 2.7 \text{ V}$	$V_{CC} = \text{MAX}$
				100	μA	$V_{IN} = 7.0 \text{ V}$	
I_{IL}	Input LOW Current S_0 - S_2 Inputs			-0.6	mA	$V_{IN} = 0.5 \text{ V}$	$V_{CC} = \text{MAX}$
	Other Inputs			-2.4	mA	$V_{IN} = 0.5 \text{ V}$	
I_{OS}	Output Short Circuit Current (Note 2)	-60		-150	mA	$V_{OUT} = 0 \text{ V}$	$V_{CC} = \text{MAX}$
I_{CC}	Power Supply Current		59	89	mA	S_0 - $S_2 = \text{GND}$; Other Inputs HIGH	$V_{CC} = \text{MAX}$

NOTES:

- For conditions such as MIN or MAX, use the appropriate value specified under guaranteed operating ranges.
- Not more than one output should be shorted at a time, nor for more than 1 second.

4

FUNCTIONAL DESCRIPTION

Signals applied to the Select inputs S_0 - S_2 determine the mode of operation, as indicated in the Function Select Table. An extensive listing of input and output levels is shown in the Truth Table. The circuit performs the arithmetic functions for either active-HIGH or active-LOW operands, with output levels in the same convention. In the Subtract operating modes, it is necessary to force a carry (HIGH for active-HIGH oper-

ands, LOW for active-LOW operands) into the C_n input of the least significant package.

The Carry Generate (\bar{G}) and Carry Propagate (\bar{P}) outputs supply input signals to the F182 carry lookahead generator for expansion to longer word length, as shown in Figure 1. Note that an F382 ALU is used for the most significant package. Typical delays for Figure 1 are given in Figure 2.

FUNCTION SELECT TABLE

Select			Operation
S_0	S_1	S_2	
L	L	L	Clear
H	L	L	B Minus A
L	H	L	A Minus B
H	H	L	A Plus B
L	L	H	$A \oplus B$
H	L	H	$A + B$
L	H	H	AB
H	H	H	Preset

H = HIGH Voltage Level

L = LOW Voltage Level

MC54/74F381

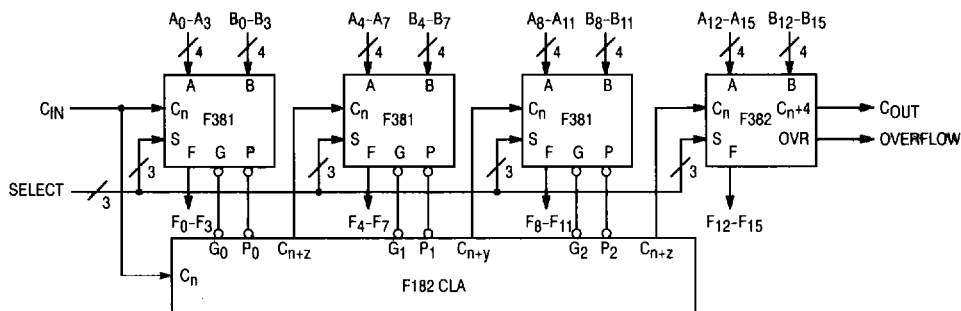

Figure 1. 16-Bit Lookahead Carry ALU Expansion

Path Segment	Toward F	Output $C_n + 4, OVR$
A_i or B_i to P	7.2 ns	7.2 ns
P_i to C_{n+j} ('F182)	6.2 ns	6.2 ns
C_n to F	8.1 ns	—
C_n to C_{n+4}, OVR	—	8.0 ns
Total Delay	21.5 ns	21.4 ns

Figure 2. 16-Bit Delay Tabulation

4

AC CHARACTERISTICS

Symbol	Parameter	54/74F			54F		74F		Unit
		$T_A = +25^\circ\text{C}$ $V_{CC} = +5.0\text{ V}$ $C_L = 50\text{ pF}$			$T_A = -55\text{ to }+125^\circ\text{C}$ $V_{CC} = 5.0\text{ V} \pm 10\%$ $C_L = 50\text{ pF}$		$T_A = 0\text{ to }+70^\circ\text{C}$ $V_{CC} = 5.0\text{ V} \pm 10\%$ $C_L = 50\text{ pF}$		
		Min	Typ	Max	Min	Max	Min	Max	
t_{PLH}	Propagation Delay	2.5	8.1	12	2.5	15	2.5	13	ns
t_{PHL}	C_n to F_i	2.5	5.7	8.0	2.5	11	2.5	9.0	
t_{PLH}	Propagation Delay	4.0	10.4	15	4.0	18	4.0	16	ns
t_{PHL}	Any A or B to Any F	3.5	8.2	11	3.5	14	3.5	12	
t_{PLH}	Propagation	4.5	8.3	20	4.5	23.5	4.5	21.5	ns
t_{PHL}	S_i to F_i	4.0	8.2	13	4.0	16	4.0	14	
t_{PLH}	Propagation Delay	3.0	6.4	9.0	3.0	12	3.0	10	ns
t_{PHL}	A_i or B_i to \bar{G}	4.0	6.8	10	4.0	13	4.0	11	
t_{PLH}	Propagation Delay	2.5	7.2	10.5	2.5	13.5	2.5	11.5	ns
t_{PHL}	A_i or B_i to \bar{P}	3.5	6.5	9.5	3.5	12.5	3.5	10.5	
t_{PLH}	Propagation Delay	4.0	7.8	12	4.0	15	4.0	13	ns
t_{PHL}	S_i to G or P	4.5	10.2	13.5	4.5	16.5	4.5	14.5	

MC54/74F381

TRUTH TABLE

FUNCTION	INPUTS						OUTPUTS								
	S ₀	S ₁	S ₂	C _n	A _n	B _n	F ₀	F ₁	F ₂	F ₃	\bar{G}	P			
CLEAR	0	0	0	X	X	X	0	0	0	0	0	0			
B MINUS A	1	0	0	0	0	0	1	1	1	1	1	0			
				0	0	1	0	1	1	1	0	0			
				0	1	0	0	0	0	0	0	1	1		
				0	1	1	1	1	1	1	1	1	0		
				1	0	0	0	0	0	0	0	0	1	0	
				1	0	1	1	1	1	1	1	1	0	0	
				1	1	0	1	0	0	1	0	0	0	1	1
				1	1	1	1	1	1	0	0	0	0	1	0
A MINUS B	0	1	0	0	0	0	1	1	1	1	1	0			
				0	0	1	0	0	0	0	0	1	1		
				0	1	0	0	1	1	1	1	0	0		
				0	1	1	1	1	1	1	1	1	0		
				1	0	0	0	0	0	0	0	0	1	0	
				1	0	1	1	1	0	0	0	0	1	1	
				1	1	0	1	0	1	1	1	1	0	0	
				1	1	1	1	1	1	0	0	0	0	1	0
A PLUS B	1	1	0	0	0	0	0	0	0	0	0	1			
				0	0	1	1	1	1	1	1	0			
				0	1	0	1	1	1	1	1	1	0		
				0	1	1	1	1	1	1	1	0	0		
				1	0	0	1	0	0	0	0	0	1	1	
				1	0	1	0	0	0	0	0	0	1	0	
				1	1	0	0	0	0	0	0	0	1	0	
				1	1	1	1	1	1	1	1	1	0	0	
A⊕B	0	0	1	X	0	0	0	0	0	0	0	0			
				X	0	1	1	1	1	1	1	1			
				X	1	0	1	1	1	1	1	0			
				X	1	1	0	0	0	0	0	0			
A+B	1	0	1	X	0	0	0	0	0	0	0				
				X	0	1	1	1	1	1	1				
				X	1	0	1	1	1	1	1				
				X	1	1	1	1	1	1	1				
AB	0	1	1	X	0	0	0	0	0	0	0				
				X	0	1	0	0	0	0	0				
				X	1	0	0	0	0	0	0				
				X	1	1	1	1	1	1	1				
PRESET	1	1	1	X	0	0	1	1	1	1	1				
				X	0	1	1	1	1	1	1				
				X	1	0	1	1	1	1	1				
				X	1	1	1	1	1	1	0				

1 = HIGH Voltage Level
 0 = LOW Voltage Level
 X = Immaterial