

## ADSP-21362/ADSP-21363/ADSP-21364/ADSP-21365/ADSP-21366

### SUMMARY

High performance, 32-bit/40-bit, floating-point processor optimized for high performance processing  
 Single-instruction, multiple-data (SIMD) computational architecture  
 On-chip memory—3M bit of on-chip SRAM  
 Code compatible with all other members of the SHARC family

The ADSP-2136x processors are available with a 333 MHz core instruction rate and unique peripherals such as the digital audio interface, S/PDIF transceiver, DTCP (digital transmission content protection protocol), serial ports, 8-channel asynchronous sample rate converter, precision clock generators, and more. For complete ordering information, see [Ordering Guide on Page 53](#).

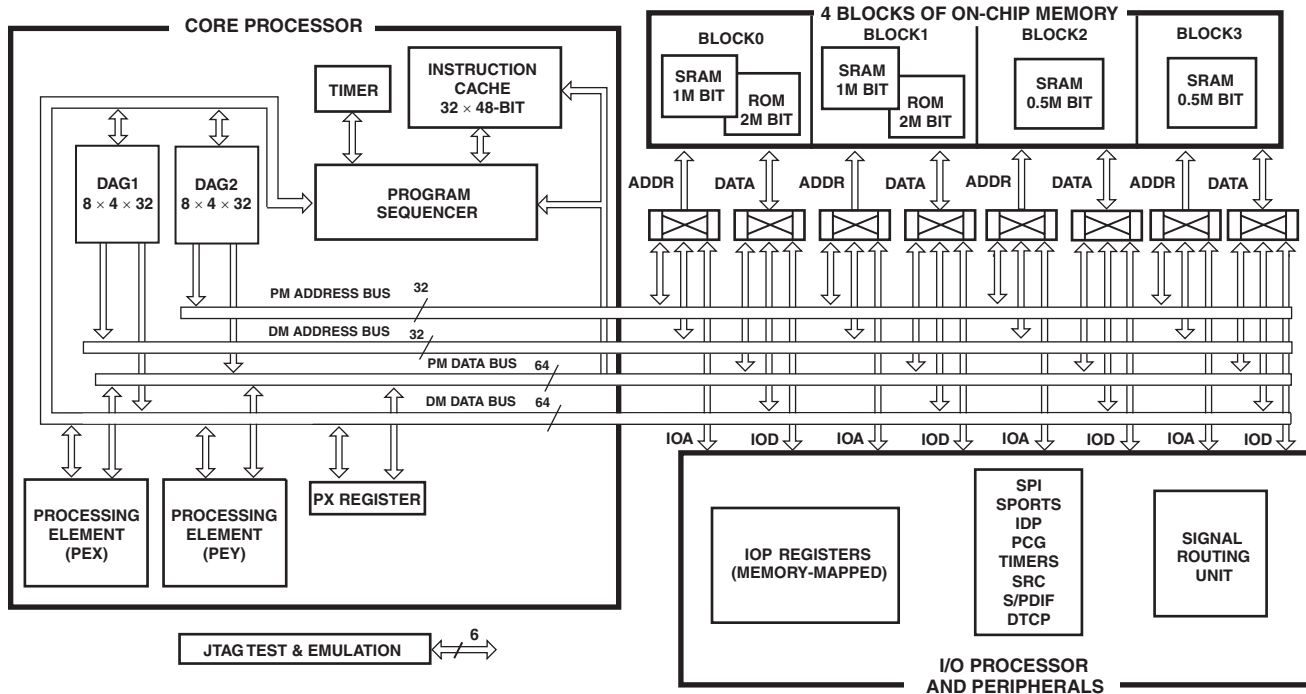

**SHARC**<sup>®</sup>

Figure 1. Functional Block Diagram—Processor Core

SHARC and the SHARC logo are registered trademarks of Analog Devices, Inc.

### Rev. C

Information furnished by Analog Devices is believed to be accurate and reliable. However, no responsibility is assumed by Analog Devices for its use, nor for any infringements of patents or other rights of third parties that may result from its use. Specifications subject to change without notice. No license is granted by implication or otherwise under any patent or patent rights of Analog Devices. Trademarks and registered trademarks are the property of their respective owners.

# ADSP-21362/ADSP-21363/ADSP-21364/ADSP-21365/ADSP-21366

## KEY FEATURES—PROCESSOR CORE

- At 333 MHz (3.0 ns) core instruction rate, the ADSP-2136x performs 2 GFLOPS/666 MMACS
- 3M bit on-chip SRAM (1M bit in blocks 0 and 1, and 0.50M bit in blocks 2 and 3) for simultaneous access by the core processor and DMA
- 4M bit on-chip ROM (2M bit in block 0 and 2M bit in block 1)
- Dual data address generators (DAGs) with modulo and bit-reverse addressing
- Zero-overhead looping with single-cycle loop setup, providing efficient program sequencing
- Single-instruction multiple-data (SIMD) architecture provides:
  - Two computational processing elements
  - Concurrent execution
  - Code compatibility with other SHARC family members at the assembly level
  - Parallelism in buses and computational units allows single cycle execution (with or without SIMD) of a multiply operation, an ALU operation, a dual memory read or write, and an instruction fetch
- Transfers between memory and core at a sustained 5.4 GBps bandwidth at 333 MHz core instruction rate

## INPUT/OUTPUT FEATURES

- DMA controller supports:
  - 25 DMA channels for transfers between ADSP-2136x internal memory and a variety of peripherals
  - 32-bit DMA transfers at peripheral clock speed, in parallel with full-speed processor execution
- Asynchronous parallel port provides access to asynchronous external memory
- 16 multiplexed address/data lines support 24-bit address external address range with 8-bit data or 16-bit address external address range with 16-bit data
  - 55 Mbps transfer rate
- External memory access in a dedicated DMA channel
  - 8-bit to 32-bit and 16-bit to 32-bit packing options
- Programmable data cycle duration: 2 CCLK to 31 CCLK
- Digital audio interface (DAI) includes six serial ports, two precision clock generators, an input data port, three timers, an S/PDIF transceiver, a DTCP cipher, an 8-channel asynchronous sample rate converter, an SPI port, and a signal routing unit
- Six dual data line serial ports that operate at up to 41.67 Mbps on each data line—each has a clock, frame sync, and two data lines that can be configured as either a receiver or transmitter pair
- Left-justified sample pair and I<sup>2</sup>S support, programmable direction for up to 24 simultaneous receive or transmit channels using two I<sup>2</sup>S-compatible stereo devices per serial port
- TDM support for telecommunications interfaces including 128 TDM channel support for newer telephony interfaces such as H.100/H.110

- Up to 12 TDM stream support, each with 128 channels per frame
- Companding selection on a per channel basis in TDM mode
- Input data port provides an additional input path to the processor core, configurable as eight channels of serial data or seven channels of serial data, and up to a 20-bit wide parallel data channel
- Signal routing unit provides configurable and flexible connections between all DAI components—six serial ports, one SPI port, eight channels of asynchronous sample rate converters, an S/PDIF receiver/transmitter, three timers, an SPI port, 10 interrupts, six flag inputs, six flag outputs, and 20 SRU I/O pins (DAI\_Px)
- Two serial peripheral interfaces (SPI): primary on dedicated pins, secondary on DAI pins provide:
  - Master or slave serial boot through primary SPI
  - Full-duplex operation
  - Master slave mode multimaster support
  - Open drain outputs
  - Programmable baud rates, clock polarities, and phases
- 3 muxed flag/ $\overline{\text{IRQ}}$  lines
- 1 muxed flag/timer expired line

## DEDICATED AUDIO COMPONENTS

- S/PDIF-compatible digital audio receiver/transmitter supports:
  - EIAJ CP-340 (CP-1201), IEC-958, AES/EBU standards
  - Left-justified, I<sup>2</sup>S, or right-justified serial data input with 16-, 18-, 20-, or 24-bit word widths (transmitter)
  - Two channel mode and single channel double frequency (SCDF) mode
- Sample rate converter (SRC) contains a serial input port, de-emphasis filter, sample rate converter (SRC), and serial output port providing up to -140 dB SNR performance (see [Table 2 on Page 4](#))
  - Supports left-justified, I<sup>2</sup>S, TDM, and right-justified 24-, 20-, 18-, and 16-bit serial formats (input)
- Pulse-width modulation provides:
  - 16 PWM outputs configured as four groups of four outputs
  - Supports center-aligned or edge-aligned PWM waveforms
  - Can generate complementary signals on two outputs in paired mode or independent signals in nonpaired mode
- ROM-based security features include:
  - JTAG access to memory permitted with a 64-bit key
  - Protected memory regions that can be assigned to limit access under program control to sensitive code
- PLL has a wide variety of software and hardware multiplier/divider ratios
- Dual voltage: 3.3 V I/O, 1.2 V, or 1.0 V core
- Available in 136-ball BGA and 144-lead LQFP\_EP packages (see [Ordering Guide on Page 53](#))

## CONTENTS

Summary .....	1
Key Features—Processor Core .....	2
Input/Output Features .....	2
Dedicated Audio Components .....	2
Contents .....	3
Revision History .....	3
General Description .....	4
SHARC Family Core Architecture .....	5
Memory and I/O Interface Features .....	6
Development Tools .....	10
Additional Information .....	11
Pin Function Descriptions .....	12
Address Data Pins as FLAGS .....	15
Address/Data Modes .....	15
Boot Modes .....	15
Core Instruction Rate to CLKIN Ratio Modes .....	15
ADSP-2136x Specifications .....	16
Operating Conditions .....	16
Electrical Characteristics .....	16
Package Information .....	17
ESD Caution .....	17
Maximum Power Dissipation .....	17
Absolute Maximum Ratings .....	17
Timing Specifications .....	17
Output Drive Currents .....	45
Test Conditions .....	45
Capacitive Loading .....	45
Thermal Characteristics .....	46
144-Lead LQFP Pin Configurations .....	47
136-Ball BGA Pin Configurations .....	48
Outline Dimensions .....	51
Surface Mount Design .....	52
Ordering Guide .....	53

## REVISION HISTORY

9/07—Rev B. to Rev C.

Added additional information to Timing Specifications ....	17
Revised Figure 6 .....	18
Revised Table 12 .....	18
Revised Table 21 .....	24
Revised Ordering Guide .....	53

# ADSP-21362/ADSP-21363/ADSP-21364/ADSP-21365/ADSP-21366

## GENERAL DESCRIPTION

The ADSP-2136x SHARC® processor is a member of the SIMD SHARC family of DSPs that feature Analog Devices' Super Harvard Architecture. The processor is source code-compatible with the ADSP-2126x and ADSP-2116x DSPs, as well as with first generation ADSP-2106x SHARC processors in SISD (single-instruction, single-data) mode. The ADSP-2136x is a 32-bit/40-bit floating-point processor optimized for high performance automotive audio applications with a large on-chip SRAM and ROM, multiple internal buses to eliminate I/O bottlenecks, and an innovative digital audio interface (DAI).

As shown in the functional block diagram on Page 1, the ADSP-2136x uses two computational units to deliver a significant performance increase over the previous SHARC processors on a range of signal processing algorithms. Fabricated in a state-of-the-art, high speed, CMOS process, the ADSP-2136x processor achieves an instruction cycle time of 3.0 ns at 333 MHz. With its SIMD computational hardware, the ADSP-2136x can perform two GFLOPS running at 333 MHz.

Table 2 shows the features of the individual product offerings and Table 1 shows performance benchmarks for the processors running at 333 MHz.

**Table 1. Benchmarks (at 333 MHz)**

Benchmark Algorithm	Speed (at 333 MHz)
1024 Point Complex FFT (Radix 4, with reversal)	27.9 $\mu$ s
FIR Filter (per tap) <sup>1</sup>	1.5 ns
IIR Filter (per biquad) <sup>1</sup>	6.0 ns
Matrix Multiply (pipelined)	
[3 $\times$ 3] $\times$ [3 $\times$ 1]	13.5 ns
[4 $\times$ 4] $\times$ [4 $\times$ 1]	23.9 ns
Divide (y/x)	10.5 ns
Inverse Square Root	16.3 ns

<sup>1</sup> Assumes two files in multichannel SIMD mode

The ADSP-2136x continues SHARC's industry-leading standards of integration for DSPs, combining a high performance 32-bit DSP core with integrated, on-chip system features.

The block diagram on Page 1, illustrates the following architectural features:

- Two processing elements, each of which comprises an ALU, multiplier, shifter, and data register file
- Data address generators (DAG1, DAG2)
- Program sequencer with instruction cache
- PM and DM buses capable of supporting four 32-bit data transfers between memory and the core at every core processor cycle
- Three programmable interval timers with PWM generation, PWM capture/pulse width measurement, and external event counter capabilities
- On-chip SRAM (3M bit)

- On-chip ROM (4M bit)
- JTAG test access port

**Table 2. ADSP-2136x SHARC Processor Family Features**

Feature	ADSP-21362	ADSP-21363	ADSP-21364	ADSP-21365	ADSP-21366
RAM	3M bit	3M bit	3M bit	3M bit	3M bit
ROM	4M bit	4M bit	4M bit	4M bit	4M bit
Audio Decoders in ROM <sup>1</sup>	No	No	No	Yes	Yes
Pulse-Width Modulation	Yes	Yes	Yes	Yes	Yes
S/PDIF	Yes	No	Yes	Yes	Yes
DTCP <sup>2</sup>	Yes	No	No	Yes	No
SRC Performance	128 dB	No SRC	140 dB	128 dB	128 dB

<sup>1</sup> Audio decoding algorithms include PCM, Dolby Digital EX, Dolby Prologic IIx, DTS 96/24, Neo:6, DTS ES, MPEG-2 AAC, MP3, and functions like bass management, delay, speaker equalization, graphic equalization, and more. Decoder/post-processor algorithm combination support varies depending upon the chip version and the system configurations. Please visit [www.analog.com](http://www.analog.com) for complete information.

<sup>2</sup> The ADSP-21362 and ADSP-21365 processors provide the Digital Transmission Content Protection protocol, a proprietary security protocol. Contact your Analog Devices sales office for more information.

The block diagram on Page 8 illustrates the following architectural features:

- DMA controller
- Six full duplex serial ports
- Two SPI-compatible interface ports—primary on dedicated pins, secondary on DAI pins
- 8-bit or 16-bit parallel port that supports interfaces to off-chip memory peripherals
- Digital audio interface that includes two precision clock generators (PCG), an input data port (IDP), an S/PDIF receiver/transmitter, eight channels asynchronous sample rate converter, DTCP cipher, six serial ports, eight serial interfaces, a 20-bit parallel input port, 10 interrupts, six flag outputs, six flag inputs, three timers, and a flexible signal routing unit (SRU)

Figure 2 shows a sample SPORT configuration using the precision clock generators to interface with an I<sup>2</sup>S ADC and an I<sup>2</sup>S DAC with a much lower jitter clock than the serial port would generate itself. Many other SRU configurations are possible.

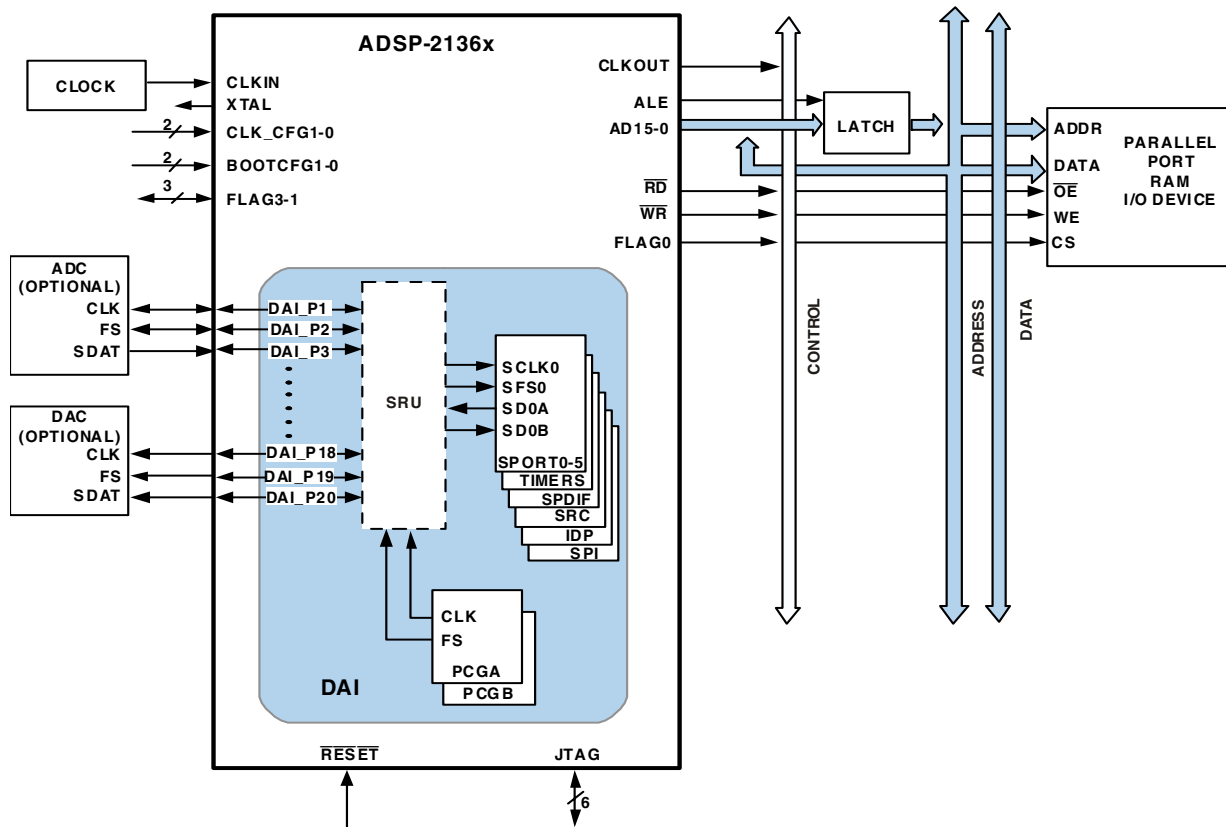

Figure 2. ADSP-2136x System Sample Configuration

## SHARC FAMILY CORE ARCHITECTURE

The ADSP-2136x is code-compatible at the assembly level with the ADSP-2126x, ADSP-21160, and ADSP-21161, and with the first generation ADSP-2106x SHARC processors. The ADSP-2136x shares architectural features with the ADSP-2126x and ADSP-2116x SIMD SHARC processors, as detailed in the following sections.

### SIMD Computational Engine

The ADSP-2136x contains two computational processing elements that operate as a single-instruction multiple-data (SIMD) engine. The processing elements are referred to as PEX and PEY and each contains an ALU, multiplier, shifter, and register file. PEX is always active, and PEY may be enabled by setting the PEYEN mode bit in the MODE1 register. When this mode is enabled, the same instruction is executed in both processing elements, but each processing element operates on different data. This architecture is efficient at executing math intensive signal processing algorithms.

Entering SIMD mode also has an effect on the way data is transferred between memory and the processing elements. When in SIMD mode, twice the data bandwidth is required to sustain computational operation in the processing elements. Because of this requirement, entering SIMD mode also doubles the

bandwidth between memory and the processing elements. When using the DAGs to transfer data in SIMD mode, two data values are transferred with each access of memory or the register file.

### Independent, Parallel Computation Units

Within each processing element is a set of computational units. The computational units consist of an arithmetic/logic unit (ALU), multiplier, and shifter. These units perform all operations in a single cycle. The three units within each processing element are arranged in parallel, maximizing computational throughput. Single multifunction instructions execute parallel ALU and multiplier operations. In SIMD mode, the parallel ALU and multiplier operations occur in both processing elements. These computation units support IEEE 32-bit, single-precision floating-point, 40-bit extended-precision floating-point, and 32-bit fixed-point data formats.

### Data Register File

A general-purpose data register file is contained in each processing element. The register files transfer data between the computation units and the data buses, and store intermediate results. These 10-port, 32-register (16 primary, 16 secondary) register files, combined with the ADSP-2136x enhanced

# ADSP-21362/ADSP-21363/ADSP-21364/ADSP-21365/ADSP-21366

Harvard architecture, allow unconstrained data flow between computation units and internal memory. The registers in PEX are referred to as R0–R15 and in PEY as S0–S15.

## **Single-Cycle Fetch of Instruction and Four Operands**

The ADSP-2136x features an enhanced Harvard architecture in which the data memory (DM) bus transfers data and the program memory (PM) bus transfers both instructions and data (see [Figure 1 on Page 1](#)). With the processor's separate program and data memory buses and on-chip instruction cache, the processor can simultaneously fetch four operands (two over each data bus) and one instruction (from the cache), all in a single cycle.

## **Instruction Cache**

The ADSP-2136x includes an on-chip instruction cache that enables three-bus operation for fetching an instruction and four data values. The cache is selective—only the instructions whose fetches conflict with PM bus data accesses are cached. This cache allows full-speed execution of core, looped operations such as digital filter multiply-accumulates, and FFT butterfly processing.

## **Data Address Generators with Zero-Overhead Hardware Circular Buffer Support**

The ADSP-2136x's two data address generators (DAGs) are used for indirect addressing and implementing circular data buffers in hardware. Circular buffers allow efficient programming of delay lines and other data structures required in digital signal processing, and are commonly used in digital filters and Fourier transforms. The two DAGs contain sufficient registers to allow the creation of up to 32 circular buffers (16 primary register sets, 16 secondary). The DAGs automatically handle address pointer wraparound, reduce overhead, increase performance, and simplify implementation. Circular buffers can start and end at any memory location.

## **Flexible Instruction Set**

The 48-bit instruction word accommodates a variety of parallel operations, for concise programming. For example, the ADSP-2136x can conditionally execute a multiply, an add, and a subtract in both processing elements while branching and fetching up to four 32-bit values from memory—all in a single instruction.

## **MEMORY AND I/O INTERFACE FEATURES**

The ADSP-2136x adds the following architectural features to the SIMD SHARC family core.

### **On-Chip Memory**

The ADSP-2136x contains three megabits of internal SRAM and four megabits of internal ROM. Each block can be configured for different combinations of code and data storage (see [Table 3](#)). Each memory block supports single-cycle, independent accesses by the core processor and I/O processor. The processor's memory architecture, in combination with its separate on-chip buses, allows two data transfers from the core and one from the I/O processor, in a single cycle.

The SRAM can be configured as a maximum of 96K words of 32-bit data, 192K words of 16-bit data, 64K words of 48-bit instructions (or 40-bit data), or combinations of different word sizes up to three megabits. All of the memory can be accessed as 16-bit, 32-bit, 48-bit, or 64-bit words. A 16-bit floating-point storage format is supported that effectively doubles the amount of data that may be stored on-chip. Conversion between the 32-bit floating-point and 16-bit floating-point formats is performed in a single instruction. While each memory block can store combinations of code and data, accesses are most efficient when one block stores data using the DM bus for transfers, and the other block stores instructions and data using the PM bus for transfers.

Using the DM bus and PM buses, with one bus dedicated to each memory block, assures single-cycle execution with two data transfers. In this case, the instruction must be available in the cache.

### **DMA Controller**

The ADSP-2136x's on-chip DMA controllers allow data transfers without processor intervention. The DMA controller operates independently and invisibly to the processor core, allowing DMA operations to occur while the core is simultaneously executing its program instructions. DMA transfers can occur between the processor's internal memory and its serial ports, the SPI-compatible (serial peripheral interface) ports, the IDP (input data port), the parallel data acquisition port (PDAP), or the parallel port. Twenty-five channels of DMA are available on the processors—two for the SPI interface, 12 via the serial ports, eight via the input data port, two for DTCP (or memory-to-memory data transfer when DTCP is not used), and one via the processor's parallel port. Programs can be downloaded to the processors using DMA transfers. Other DMA features include interrupt generation upon completion of DMA transfers, and DMA chaining for automatic linked DMA transfers.

### **Digital Audio Interface (DAI)**

The digital audio interface (DAI) provides the ability to connect various peripherals to any of the DSP's DAI pins (DAI\_P20–1).

Programs make these connections using the signal routing unit (SRU, shown in [Figure 3](#)).

The SRU is a matrix routing unit (or group of multiplexers) that enables the peripherals provided by the DAI to be interconnected under software control. This allows easy use of the DAI-associated peripherals for a much wider variety of applications by using a larger set of algorithms than is possible with nonconfigurable signal paths.

The DAI also includes six serial ports, an S/PDIF receiver/transmitter, a DTCP cipher, a precision clock generator (PCG), eight channels of asynchronous sample rate converters, an input data port (IDP), an SPI port, six flag outputs and six flag inputs, and three timers. The IDP provides an additional input path to the ADSP-2136x core, configurable as either eight channels of I<sup>2</sup>S serial data or as seven channels plus a single 20-bit wide synchronous parallel data acquisition port. Each data channel has its own DMA channel that is independent from the processor's serial ports.

# ADSP-21362/ADSP-21363/ADSP-21364/ADSP-21365/ADSP-21366

**Table 3. ADSP-2136x Internal Memory Space**

<b>IOP Registers 0x0000 0000–0003 FFFF</b>			
<b>Long Word (64 Bits)</b>	<b>Extended Precision Normal or Instruction Word (48 Bits)</b>	<b>Normal Word (32 Bits)</b>	<b>Short Word (16 Bits)</b>
BLOCK 0 ROM 0x0004 0000–0x0004 7FFF	BLOCK 0 ROM 0x0008 0000–0x0008 AAA9	BLOCK 0 ROM 0x0008 0000–0x0008 FFFF	BLOCK 0 ROM 0x0010 0000–0x0011 FFFF
Reserved 0x0004 8000–0x0004 BFFF		Reserved 0x0009 0000–0x0009 7FFF	Reserved 0x0012 0000–0x0012 FFFF
BLOCK 0 SRAM 0x0004 C000–0x0004 FFFF	BLOCK 0 SRAM 0x0009 0000–0x0009 5554	BLOCK 0 SRAM 0x0009 8000–0x0009 FFFF	BLOCK 0 SRAM 0x0013 0000–0x0013 FFFF
BLOCK 1 ROM 0x0005 0000–0x0005 7FFF	BLOCK 1 ROM 0x000A 0000–0x000A AAA9	BLOCK 1 ROM 0x000A 0000–0x000A FFFF	BLOCK 1 ROM 0x0014 0000–0x0015 FFFF
Reserved 0x0005 8000–0x0005 BFFF		Reserved 0x000B 0000–0x000B 7FFF	Reserved 0x0016 0000–0x0016 FFFF
BLOCK 1 SRAM 0x0005 C000–0x0005 FFFF	BLOCK 1 SRAM 0x000B 0000–0x000B 5554	BLOCK 1 SRAM 0x000B 8000–0x000B FFFF	BLOCK 1 SRAM 0x0017 0000–0x0017 FFFF
BLOCK 2 SRAM 0x0006 0000–0x0006 1FFF	BLOCK 2 SRAM 0x000C 0000–0x000C 2AA9	BLOCK 2 SRAM 0x000C 0000–0x000C 3FFF	BLOCK 2 SRAM 0x0018 0000–0x0018 7FFF
Reserved 0x0006 2000–0x0006 FFFF		Reserved 0x000C 4000–0x000D FFFF	Reserved 0x0018 8000–0x001B FFFF
BLOCK 3 SRAM 0x0007 0000–0x0007 1FFF	BLOCK 3 SRAM 0x000E 0000–0x000E 2AA9	BLOCK 3 SRAM 0x000E 0000–0x000E 3FFF	BLOCK 3 SRAM 0x001C 0000–0x001C 7FFF
Reserved 0x0007 2000–0x0007 FFFF		Reserved 0x000E 4000–0x000F FFFF	Reserved 0x001C 8000–0x001F FFFF
			Reserved 0x0020 0000–0xFFFF FFFF

For complete information on using the DAI, see the *ADSP-2136x SHARC Processor Hardware Reference*.

### Serial Ports

The ADSP-2136x features six synchronous serial ports that provide an inexpensive interface to a wide variety of digital and mixed-signal peripheral devices such as Analog Devices’ AD183x family of audio codecs, ADCs, and DACs. The serial ports are made up of two data lines, a clock, and a frame sync. The data lines can be programmed to either transmit or receive and each data line has a dedicated DMA channel.

Serial ports are enabled via 12 programmable and simultaneous receive or transmit pins that support up to 24 transmit or 24 receive channels of audio data when all six SPORTS are enabled, or six full duplex TDM streams of 128 channels per frame.

The serial ports operate at a maximum data rate of 41.67 Mbps. Serial port data can be automatically transferred to and from on-chip memory via dedicated DMA channels. Each of the serial ports can work in conjunction with another serial port to provide TDM support. One SPORT provides two transmit signals while the other SPORT provides the two receive signals. The frame sync and clock are shared.

Serial ports operate in four modes:

- Standard DSP serial mode
- Multichannel (TDM) mode
- I<sup>2</sup>S mode
- Left-justified sample pair mode

Left-justified sample pair mode is a mode where in each frame sync cycle two samples of data are transmitted/received—one sample on the high segment of the frame sync, the other on the low segment of the frame sync. Programs have control over various attributes of this mode.

Each of the serial ports supports the left-justified sample pair and I<sup>2</sup>S protocols (I<sup>2</sup>S is an industry-standard interface commonly used by audio codecs, ADCs, and DACs, such as the Analog Devices AD183x family), with two data pins, allowing four left-justified sample pairs or I<sup>2</sup>S channels (using two stereo devices) per serial port, with a maximum of up to 24 I<sup>2</sup>S channels. The serial ports permit little-endian or big-endian transmission formats and word lengths selectable from 3 bits to 32 bits. For the left-justified sample pair and I<sup>2</sup>S modes, data-word lengths are selectable between 8 bits and 32 bits. Serial ports offer selectable synchronization and transmit modes as well as optional  $\mu$ -law or A-law companding selection on a per channel basis. Serial port clocks and frame syncs can be internally or externally generated.

# ADSP-21362/ADSP-21363/ADSP-21364/ADSP-21365/ADSP-21366

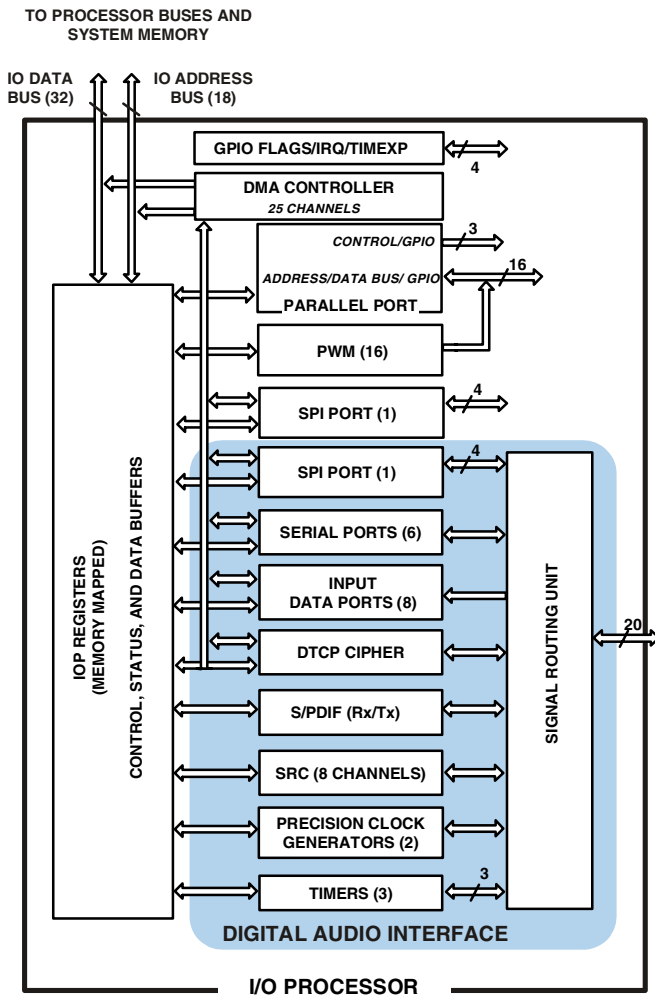

Figure 3. ADSP-2136x I/O Processor and Peripherals Block Diagram

## Parallel Port

The parallel port provides interfaces to SRAM and peripheral devices. The multiplexed address and data pins (AD15–0) can access 8-bit devices with up to 24 bits of address, or 16-bit devices with up to 16 bits of address. In either mode, 8-bit or 16-bit, the maximum data transfer rate is 55 Mbps.

DMA transfers are used to move data to and from internal memory. Access to the core is also facilitated through the parallel port register read/write functions. The  $\overline{RD}$ ,  $\overline{WR}$ , and ALE (address latch enable) pins are the control pins for the parallel port.

## Serial Peripheral (Compatible) Interface

The processors contain two serial peripheral interface ports (SPIs). The SPI is an industry-standard synchronous serial link, enabling the ADSP-2136x SPI-compatible port to communicate with other SPI-compatible devices. The SPI consists of two data

pins, one device select pin, and one clock pin. It is a full-duplex synchronous serial interface, supporting both master and slave modes and can operate at a maximum baud rate of 41.67 MHz.

The SPI port can operate in a multimaster environment by interfacing with up to four other SPI-compatible devices, either acting as a master or slave device. The ADSP-2136x SPI-compatible peripheral implementation also features programmable baud rate, clock phase, and polarities. The SPI-compatible port uses open drain drivers to support a multimaster configuration and to avoid data contention.

## S/PDIF-Compatible Digital Audio Receiver/Transmitter and Synchronous/Asynchronous Sample Rate Converter

The S/PDIF transmitter has no separate DMA channels. It receives audio data in serial format and converts it into a biphasic encoded signal. The serial data input to the transmitter can be formatted as left-justified, I<sup>2</sup>S, or right-justified with word widths of 16, 18, 20, or 24 bits.

The serial data, clock, and frame sync inputs to the S/PDIF transmitter are routed through the signal routing unit (SRU). They can come from a variety of sources such as the SPORTs, external pins, the precision clock generators (PCGs), or the sample rate converters (SRC) and are controlled by the SRU control registers.

The sample rate converter (SRC) contains four SRC blocks and is the same core as that used in the AD1896 192 kHz stereo asynchronous sample rate converter and provides up to 140 dB SNR (see Table 2 on Page 4 for details). The SRC block is used to perform synchronous or asynchronous sample rate conversion across independent stereo channels, without using internal processor resources. The four SRC blocks can also be configured to operate together to convert multichannel audio data without phase mismatches. Finally, the SRC is used to clean up audio data from jittery clock sources such as the S/PDIF receiver. The S/PDIF and SRC are not available on the ADSP-21363 models.

## Digital Transmission Content Protection

The DTCP specification defines a cryptographic protocol for protecting audio entertainment content from illegal copying, intercepting, and tampering as it traverses high performance digital buses, such as the IEEE 1394 standard. Only legitimate entertainment content delivered to a source device via another approved copy protection system (such as the DVD content scrambling system) will be protected by this copy protection system. This feature is available on the ADSP-21362 and ADSP-21365 processors only. Licensing through DTLA is required for these products. Visit [www.dtcp.com](http://www.dtcp.com) for more information.

## Pulse-Width Modulation

The PWM module is a flexible, programmable, PWM waveform generator that can be programmed to generate the required switching patterns for various applications related to motor and engine control or audio power control. The PWM generator can generate either center-aligned or edge-aligned PWM waveforms. In addition, it can generate complementary signals on

two outputs in paired mode or independent signals in non-paired mode (applicable to a single group of four PWM waveforms).

The entire PWM module has four groups of four PWM outputs each. Therefore, this module generates 16 PWM outputs in total. Each PWM group produces two pairs of PWM signals on the four PWM outputs.

The PWM generator is capable of operating in two distinct modes while generating center-aligned PWM waveforms: single update mode or double update mode. In single update mode the duty cycle values are programmable only once per PWM period. This results in PWM patterns that are symmetrical about the midpoint of the PWM period. In double update mode, a second updating of the PWM registers is implemented at the midpoint of the PWM period. In this mode, it is possible to produce asymmetrical PWM patterns that produce lower harmonic distortion in three-phase PWM inverters.

### Timers

The ADSP-2136x has a total of four timers: a core timer that can generate periodic software interrupts and three general-purpose timers that can generate periodic interrupts and be independently set to operate in one of three modes:

- Pulse waveform generation mode
- Pulse width count/capture mode
- External event watchdog mode

The core timer can be configured to use FLAG3 as a timer expired signal, and each general-purpose timer has one bidirectional pin and four registers that implement its mode of operation: a 6-bit configuration register, a 32-bit count register, a 32-bit period register, and a 32-bit pulse width register. A single control and status register enables or disables all three general-purpose timers independently.

### ROM-Based Security

The ADSP-2136x has a ROM security feature that provides hardware support for securing user software code by preventing unauthorized reading from the internal code when enabled. When using this feature, the processor does not boot-load any external code, executing exclusively from internal SRAM/ROM. Additionally, the processor is not freely accessible via the JTAG port. Instead, a unique 64-bit key, which must be scanned in through the JTAG or test access port will be assigned to each customer. The device will ignore a wrong key. Emulation features and external boot modes are only available after the correct key is scanned.

### Program Booting

The internal memory of the ADSP-2136x boots at system power-up from an 8-bit EPROM via the parallel port, an SPI master, an SPI slave, or an internal boot. Booting is determined by the boot configuration (BOOT\_CFG1–0) pins (see [Table 7 on Page 15](#)). Selection of the boot source is controlled via the SPI as either a master or slave device, or it can immediately begin executing from ROM.

### Phase-Locked Loop

The processors use an on-chip phase-locked loop (PLL) to generate the internal clock for the core. On power up, the CLK\_CFG1–0 pins are used to select ratios of 32:1, 16:1, and 6:1 (see [Table 8 on Page 15](#)). After booting, numerous other ratios can be selected via software control.

The ratios are made up of software configurable numerator values from 1 to 64 and software configurable divisor values of 1, 2, 4, and 8.

### Power Supplies

The ADSP-2136x has a separate power supply connection for the internal ( $V_{DDINT}$ ), external ( $V_{DDEXT}$ ), and analog ( $A_{VDD}/A_{VSS}$ ) power supplies. The internal and analog supplies must meet the 1.2 V requirement for K, B, and Y grade models, and the 1.0 V requirement for Y models. (For information on the temperature ranges offered for this product, see [Operating Conditions on Page 16](#), [Package Information on Page 17](#), and [Ordering Guide on Page 53](#). The external supply must meet the 3.3 V requirement. All external supply pins must be connected to the same power supply.

Note that the analog supply pin ( $A_{VDD}$ ) powers the processor's internal clock generator PLL. To produce a stable clock, it is recommended that PCB designs use an external filter circuit for the  $A_{VDD}$  pin. Place the filter components as close as possible to the  $A_{VDD}/A_{VSS}$  pins. For an example circuit, see [Figure 4](#). (A recommended ferrite chip is the muRata BLM18AG102SN1D). To reduce noise coupling, the PCB should use a parallel pair of power and ground planes for  $V_{DDINT}$  and GND. Use wide traces to connect the bypass capacitors to the analog power ( $A_{VDD}$ ) and ground ( $A_{VSS}$ ) pins. Note that the  $A_{VDD}$  and  $A_{VSS}$  pins specified in [Figure 4](#) are inputs to the processor and not the analog ground plane on the board—the  $A_{VSS}$  pin should connect directly to digital ground (GND) at the chip.

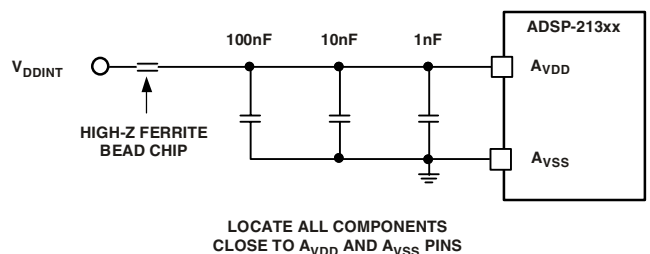

Figure 4. Analog Power ( $A_{VDD}$ ) Filter Circuit

### Target Board JTAG Emulator Connector

Analog Devices DSP Tools product line of JTAG emulators uses the IEEE 1149.1 JTAG test access port of the processor to monitor and control the target board processor during emulation. Analog Devices' DSP Tools product line of JTAG emulators provides emulation at full processor speed, allowing inspection and modification of memory, registers, and processor stacks. The processor's JTAG interface ensures that the emulator will not affect target system loading or timing.

# ADSP-21362/ADSP-21363/ADSP-21364/ADSP-21365/ADSP-21366

For complete information on Analog Devices' SHARC DSP Tools product line of JTAG emulator operation, see the appropriate *Emulator Hardware User's Guide*.

## DEVELOPMENT TOOLS

The ADSP-2136x is supported with a complete set of CROSSCORE<sup>†</sup> software and hardware development tools, including Analog Devices emulators and VisualDSP++<sup>‡</sup> development environment. The same emulator hardware that supports other SHARC processors also fully emulates the ADSP-2136x.

The VisualDSP++ project management environment lets programmers develop and debug an application. This environment includes an easy to use assembler (which is based on an algebraic syntax), an archiver (librarian/library builder), a linker, a loader, a cycle-accurate instruction-level simulator, a C/C++ compiler, and a C/C++ runtime library that includes DSP and mathematical functions. A key point for these tools is C/C++ code efficiency. The compiler has been developed for efficient translation of C/C++ code to DSP assembly. The SHARC has architectural features that improve the efficiency of compiled C/C++ code.

The VisualDSP++ debugger has a number of important features. Data visualization is enhanced by a plotting package that offers a significant level of flexibility. This graphical representation of user data enables the programmer to quickly determine the performance of an algorithm. As algorithms grow in complexity, this capability can have increasing significance on the designer's development schedule, increasing productivity. Statistical profiling enables the programmer to nonintrusively poll the processor as it is running the program. This feature, unique to VisualDSP++, enables the software developer to passively gather important code execution metrics without interrupting the real-time characteristics of the program. Essentially, the developer can identify bottlenecks in software quickly and efficiently. By using the profiler, the programmer can focus on those areas in the program that impact performance and take corrective action.

Debugging both C/C++ and assembly programs with the VisualDSP++ debugger, programmers can:

- View mixed C/C++ and assembly code (interleaved source and object information)
- Insert breakpoints
- Set conditional breakpoints on registers, memory, and stacks
- Perform linear or statistical profiling of program execution
- Fill, dump, and graphically plot the contents of memory
- Perform source level debugging
- Create custom debugger windows

The VisualDSP++ IDDE lets programmers define and manage DSP software development. Its dialog boxes and property pages let programmers configure and manage all of the SHARC development tools, including the color syntax highlighting in the VisualDSP++ editor. This capability permits programmers to:

- Control how the development tools process inputs and generate outputs
- Maintain a one-to-one correspondence with the tool's command line switches

The VisualDSP++ Kernel (VDK) incorporates scheduling and resource management tailored specifically to address the memory and timing constraints of DSP programming. These capabilities enable engineers to develop code more effectively, eliminating the need to start from the very beginning, when developing new application code. The VDK features include threads, critical and unscheduled regions, semaphores, events, and device flags. The VDK also supports priority-based, pre-emptive, cooperative, and time-sliced scheduling approaches. In addition, the VDK was designed to be scalable. If the application does not use a specific feature, the support code for that feature is excluded from the target system.

Because the VDK is a library, a developer can decide whether to use it or not. The VDK is integrated into the VisualDSP++ development environment, but can also be used via standard command line tools. When the VDK is used, the development environment assists the developer with many error-prone tasks and assists in managing system resources, automating the generation of various VDK-based objects, and visualizing the system state, when debugging an application that uses the VDK.

VisualDSP++ component software engineering (VCSE) is Analog Devices' technology for creating, using, and reusing software components (independent modules of substantial functionality) to quickly and reliably assemble software applications. It allows downloading components from the Web, dropping them into the application, and publishing component archives from within VisualDSP++. VCSE supports component implementation in C/C++ or assembly language.

Use the expert linker to visually manipulate the placement of code and data on the embedded system. View memory utilization in a color-coded graphical form, easily move code and data to different areas of the processor or external memory with a drag of the mouse and examine runtime stack and heap usage. The expert linker is fully compatible with the existing linker definition file (LDF), allowing the developer to move between the graphical and textual environments.

In addition to the software and hardware development tools available from Analog Devices, third parties provide a wide range of tools supporting the SHARC processor family. Hardware tools include SHARC processor PC plug-in cards. Third party software tools include DSP libraries, real-time operating systems, and block diagram design tools.

### **Designing an Emulator-Compatible DSP Board (Target)**

The Analog Devices family of emulators are tools that every DSP developer needs to test and debug hardware and software systems. Analog Devices has supplied an IEEE 1149.1 JTAG test

<sup>†</sup> CROSSCORE is a registered trademark of Analog Devices, Inc.

<sup>‡</sup> VisualDSP++ is a registered trademark of Analog Devices, Inc.

access port (TAP) on each JTAG processor. Nonintrusive in-circuit emulation is assured by the use of the processor's JTAG interface—the emulator does not affect target system loading or timing. The emulator uses the TAP to access the internal features of the processor, allowing the developer to load code, set breakpoints, observe variables, observe memory, and examine registers. The processor must be halted to send data and commands, but once an operation has been completed by the emulator, the DSP system is set running at full speed with no impact on system timing.

To use these emulators, the target board must include a header that connects the DSP's JTAG port to the emulator.

For details on target board design issues including mechanical layout, single processor connections, multiprocessor scan chains, signal buffering, signal termination, and emulator pod logic, see the *Analog Devices JTAG Emulation Technical Reference (EE-68)* on the Analog Devices website ([www.analog.com](http://www.analog.com))—use site search on “EE-68.” This document is updated regularly to keep pace with improvements to emulator support.

### **Evaluation Kit**

Analog Devices offers a range of EZ-KIT Lite<sup>®†</sup> evaluation platforms to use as a cost-effective method to learn more about developing or prototyping applications with Analog Devices processors, platforms, and software tools. Each EZ-KIT Lite

<sup>†</sup> EZ-KIT Lite is a registered trademark of Analog Devices, Inc.

platform includes an evaluation board along with an evaluation suite of the VisualDSP++ development and debugging environment with the C/C++ compiler, assembler, and linker. Also included are sample application programs, power supply, and a USB cable. All evaluation versions of the software tools are limited for use only with the EZ-KIT Lite product.

The USB controller on the EZ-KIT Lite board connects the board to the USB port of the user's PC, enabling the VisualDSP++ evaluation suite to emulate the on-board processor in-circuit. This permits the customer to download, execute, and debug programs for the EZ-KIT Lite system. It also allows in-circuit programming of the on-board flash device to store user-specific boot code, enabling the board to run as a stand-alone unit without being connected to the PC.

With a full version of VisualDSP++ installed (sold separately), engineers can develop software for the EZ-KIT Lite or any custom defined system. Connecting one of Analog Devices' JTAG emulators to the EZ-KIT Lite board enables high speed, non-intrusive emulation.

### **ADDITIONAL INFORMATION**

This data sheet provides a general overview of the ADSP-2136x architecture and functionality. For detailed information on the ADSP-2136x family core architecture and instruction set, refer to the *ADSP-2136x SHARC Processor Hardware Reference* and the *ADSP-2136x SHARC Processor Programming Reference*.

# ADSP-21362/ADSP-21363/ADSP-21364/ADSP-21365/ADSP-21366

## PIN FUNCTION DESCRIPTIONS

The ADSP-2136x pin definitions are listed below. Inputs identified as synchronous (S) must meet timing requirements with respect to CLKIN (or with respect to TCK for TMS and TDI). Inputs identified as asynchronous (A) can be asserted asynchronously to CLKIN (or to TCK for  $\overline{\text{TRST}}$ ). Tie or pull unused inputs to  $V_{\text{DDEXT}}$  or GND, except for the following:

DAI\_Px, SPICLK, MISO, MOSI,  $\overline{\text{EMU}}$ , TMS,  $\overline{\text{TRST}}$ , TDI, and AD15–0 (NOTE: These pins have pull-up resistors.)

The following symbols appear in the Type column of [Table 4](#): A = asynchronous, G = ground, I = input, O = output, P = power supply, S = synchronous, (A/D) = active drive, (O/D) = open drain, and T = three-state, (pd) = pull-down resistor, (pu) = pull-up resistor.

**Table 4. Pin Descriptions**

Pin	Type	State During and After Reset	Function
AD15–0	I/O/T (pu)	Three-state with pull-up enabled	<b>Parallel Port Address/Data.</b> The ADSP-2136x parallel port and its corresponding DMA unit output addresses and data for peripherals on these multiplexed pins. The multiplex state is determined by the ALE pin. The parallel port can operate in either 8-bit or 16-bit mode. Each AD pin has a 22.5 k $\Omega$ internal pull-up resistor. See <a href="#">Address/Data Modes on Page 15</a> for details of the AD pin operation. For 8-bit mode: ALE is automatically asserted whenever a change occurs in the upper 16 external address bits, A23–8; ALE is used in conjunction with an external latch to retain the values of the A23–8. For detailed information on I/O operations and pin multiplexing, see the <i>ADSP-2136x SHARC Processor Hardware Reference</i> .
$\overline{\text{RD}}$	O (pu)	Three-state, driven high <sup>1</sup>	<b>Parallel Port Read Enable.</b> $\overline{\text{RD}}$ is asserted low whenever the processor reads 8-bit or 16-bit data from an external memory device. When AD15–0 are flags, this pin remains deasserted. $\overline{\text{RD}}$ has a 22.5 k $\Omega$ internal pull-up resistor.
$\overline{\text{WR}}$	O (pu)	Three-state, driven high <sup>1</sup>	<b>Parallel Port Write Enable.</b> $\overline{\text{WR}}$ is asserted low whenever the processor writes 8-bit or 16-bit data to an external memory device. When AD15–0 are flags, this pin remains deasserted. $\overline{\text{WR}}$ has a 22.5 k $\Omega$ internal pull-up resistor.
ALE	O (pd)	Three-state, driven low <sup>1</sup>	<b>Parallel Port Address Latch Enable.</b> ALE is asserted whenever the processor drives a new address on the parallel port address pins. On reset, ALE is active high. However, it can be reconfigured using software to be active low. When AD15–0 are flags, this pin remains deasserted. ALE has a 20 k $\Omega$ internal pull-down resistor.
FLAG3–0	I/O/A	Three-state	<b>Flag Pins.</b> Each flag pin is configured via control bits as either an input or output. As an input, it can be tested as a condition. As an output, it can be used to signal external peripherals. These pins can be used as an SPI interface slave select output during SPI mastering. These pins are also multiplexed with the $\overline{\text{IRQx}}$ and the TIMEXP signals. For detailed information on I/O operations and pin multiplexing, see the <i>ADSP-2136x SHARC Processor Hardware Reference</i> .
DAI_P20–1	I/O/T (pu)	Three-state with programmable pull-up	<b>Digital Audio Interface Pins.</b> These pins provide the physical interface to the SRU. The SRU configuration registers define the combination of on-chip peripheral inputs or outputs connected to the pin and to the pin's output enable. The configuration registers of these peripherals then determines the exact behavior of the pin. Any input or output signal present in the SRU may be routed to any of these pins. The SRU provides the connection from the serial ports, input data port, precision clock generators and timers, sample rate converters and SPI to the DAI_P20–1 pins. These pins have internal 22.5 k $\Omega$ pull-up resistors which are enabled on reset. These pull-ups can be disabled in the DAI_PIN_PULLUP register.

# ADSP-21362/ADSP-21363/ADSP-21364/ADSP-21365/ADSP-21366

**Table 4. Pin Descriptions (Continued)**

Pin	Type	State During and After Reset	Function
SPICLK	I/O (pu)	Three-state with pull-up enabled	<b>Serial Peripheral Interface Clock Signal.</b> Driven by the master, this signal controls the rate at which data is transferred. The master may transmit data at a variety of baud rates. SPICLK cycles once for each bit transmitted. SPICLK is a gated clock that is active during data transfers, only for the length of the transferred word. Slave devices ignore the serial clock if the slave select input is driven inactive (high). SPICLK is used to shift out and shift in the data driven on the MISO and MOSI lines. The data is always shifted out on one clock edge and sampled on the opposite edge of the clock. Clock polarity and clock phase relative to data are programmable into the SPICTL control register and define the transfer format. SPICLK has a 22.5 k $\Omega$ internal pull-up resistor.
$\overline{\text{SPID}}\text{S}$	I	Input only	<b>Serial Peripheral Interface Slave Device Select.</b> An active low signal used to select the processor as an SPI slave device. This input signal behaves like a chip select, and is provided by the master device for the slave devices. In multimaster mode the processor's $\overline{\text{SPID}}\text{S}$ signal can be driven by a slave device to signal to the processor (as SPI master) that an error has occurred, as some other device is also trying to be the master device. If asserted low when the device is in master mode, it is considered a multimaster error. For a single-master, multiple-slave configuration where flag pins are used, this pin must be tied or pulled high to $V_{\text{DDEXT}}$ on the master device. For processor to processor SPI interaction, any of the master processor's flag pins can be used to drive the $\overline{\text{SPID}}\text{S}$ signal on the SPI slave device.
MOSI	I/O (O/D) (pu)	Three-state with pull-up enabled	<b>SPI Master Out Slave In.</b> If the ADSP-2136x is configured as a master, the MOSI pin becomes a data transmit (output) pin, transmitting output data. If the processor is configured as a slave, the MOSI pin becomes a data receive (input) pin, receiving input data. In a SPI interconnection, the data is shifted out from the MOSI output pin of the master and shifted into the MOSI input(s) of the slave(s). MOSI has a 22.5 k $\Omega$ internal pull-up resistor.
MISO	I/O (O/D) (pu)	Three-state with pull-up enabled	<b>SPI Master In Slave Out.</b> If the ADSP-2136x is configured as a master, the MISO pin becomes a data receive (input) pin, receiving input data. If the processor is configured as a slave, the MISO pin becomes a data transmit (output) pin, transmitting output data. In an SPI interconnection, the data is shifted out from the MISO output pin of the slave and shifted into the MISO input pin of the master. MISO has a 22.5 k $\Omega$ internal pull-up resistor. MISO can be configured as O/D by setting the OPD bit in the SPICTL register. <b>Note:</b> Only one slave is allowed to transmit data at any given time. To enable broadcast transmission to multiple SPI slaves, the processor's MISO pin may be disabled by setting (=1) Bit 5 (DMISO) of the SPICTL register.
BOOT_CFG1-0	I	Input only	<b>Boot Configuration Select.</b> This pin is used to select the boot mode for the processor. The BOOT_CFG pins must be valid before reset is asserted. See <a href="#">Table 7</a> for a description of the boot modes.
CLKIN	I	Input only	<b>Local Clock In.</b> Used in conjunction with XTAL. CLKIN is the ADSP-2136x clock input. It configures the ADSP-2136x to use either its internal clock generator or an external clock source. Connecting the necessary components to CLKIN and XTAL enables the internal clock generator. Connecting the external clock to CLKIN while leaving XTAL unconnected configures the processors to use the external clock source such as an external clock oscillator. The core is clocked either by the PLL output or this clock input depending on the CLK_CFG1-0 pin settings. CLKIN may not be halted, changed, or operated below the specified frequency.
XTAL	O	Output only <sup>2</sup>	<b>Crystal Oscillator Terminal.</b> Used in conjunction with CLKIN to drive an external crystal.
CLK_CFG1-0	I	Input only	<b>Core/CLKIN Ratio Control.</b> These pins set the start up clock frequency. See <a href="#">Table 8</a> for a description of the clock configuration modes. Note that the operating frequency can be changed by programming the PLL multiplier and divider in the PMCTL register at any time after the core comes out of reset.

# ADSP-21362/ADSP-21363/ADSP-21364/ADSP-21365/ADSP-21366

Table 4. Pin Descriptions (Continued)

Pin	Type	State During and After Reset	Function
RESETOUT/CLKOUT	O	Output only	<b>Reset Out/Local Clock Out.</b> Drives out the core reset signal to an external device. CLKOUT can also be configured as a reset out pin. The functionality can be switched between the PLL output clock and reset out by setting Bit 12 of the PMCTL register. The default is reset out.
$\overline{\text{RESET}}$	I/A	Input only	<b>Processor Reset.</b> Resets the ADSP-2136x to a known state. Upon deassertion, there is a 4096 CLKIN cycle latency for the PLL to lock. After this time, the core begins program execution from the hardware reset vector address. The $\overline{\text{RESET}}$ input must be asserted (low) at power-up.
TCK	I	Input only <sup>3</sup>	<b>Test Clock (JTAG).</b> Provides a clock for JTAG boundary scan. TCK must be asserted (pulsed low) after power-up or held low for proper operation of the processors.
TMS	I/S (pu)	Three-state with pull-up enabled	<b>Test Mode Select (JTAG).</b> Used to control the test state machine. TMS has a 22.5 k $\Omega$ internal pull-up resistor.
TDI	I/S (pu)	Three-state with pull-up enabled	<b>Test Data Input (JTAG).</b> Provides serial data for the boundary scan logic. TDI has a 22.5 k $\Omega$ internal pull-up resistor.
TDO	O	Three-state <sup>4</sup>	<b>Test Data Output (JTAG).</b> Serial scan output of the boundary scan path.
$\overline{\text{TRST}}$	I/A (pu)	Three-state with pull-up enabled	<b>Test Reset (JTAG).</b> Resets the test state machine. $\overline{\text{TRST}}$ must be asserted (pulsed low) after power-up or held low for proper operation of the ADSP-2136x. $\overline{\text{TRST}}$ has a 22.5 k $\Omega$ internal pull-up resistor.
$\overline{\text{EMU}}$	O (O/D) (pu)	Three-state with pull-up enabled	<b>Emulation Status.</b> Must be connected to the processor's JTAG emulators target board connector only. $\overline{\text{EMU}}$ has a 22.5 k $\Omega$ internal pull-up resistor.
V <sub>DDINT</sub>	P		<b>Core Power Supply.</b> Nominally +1.2 V dc for the K, B grade models, and 1.0 V dc for the Y grade models, and supplies the processor's core (13 pins).
V <sub>DDEXT</sub>	P		<b>I/O Power Supply.</b> Nominally +3.3 V dc (6 pins).
A <sub>VDD</sub>	P		<b>Analog Power Supply.</b> Nominally +1.2 V dc for the K, B grade models, and 1.0 V dc for the Y grade models, and supplies the processor's internal PLL (clock generator). This pin has the same specifications as V <sub>DDINT</sub> , except that added filtering circuitry is required. <a href="#">For more information, see Power Supplies on Page 9.</a>
A <sub>VSS</sub>	G		<b>Analog Power Supply Return.</b>
GND	G		<b>Power Supply Return.</b> (54 pins)

<sup>1</sup>  $\overline{\text{RD}}$ ,  $\overline{\text{WR}}$ , and ALE are three-stated (and not driven) only when  $\overline{\text{RESET}}$  is active.

<sup>2</sup> Output only is a three-state driver with its output path always enabled.

<sup>3</sup> Input only is a three-state driver with both output path and pull-up disabled.

<sup>4</sup> Three-state is a three-state driver with pull-up disabled.

## ADDRESS DATA PINS AS FLAGS

To use these pins as flags (FLAGS15–0), set (=1) Bit 20 of the SYCTL register to disable the parallel port. Then set (=1) Bits 22 to 25 in the SYCTL register accordingly.

**Table 5. AD15–0 to Flag Pin Mapping**

AD Pin	Flag Pin	AD Pin	Flag Pin
AD0	FLAG8	AD8	FLAG0
AD1	FLAG9	AD9	FLAG1
AD2	FLAG10	AD10	FLAG2
AD3	FLAG11	AD11	FLAG3
AD4	FLAG12	AD12	FLAG4
AD5	FLAG13	AD13	FLAG5
AD6	FLAG14	AD14	FLAG6
AD7	FLAG15	AD15	FLAG7

## ADDRESS/DATA MODES

The following table shows the functionality of the AD pins for 8-bit and 16-bit transfers to the parallel port. For 8-bit data transfers, ALE latches Address Bits A23–A8 when asserted, followed by Address Bits A7–A0 and Data Bits D7–D0 when deasserted. For 16-bit data transfers, ALE latches Address Bits A15–A0 when asserted, followed by Data Bits D15–D0 when deasserted.

**Table 6. Address/Data Mode Selection**

PP Data Mode	ALE	AD7–0 Function	AD15–8 Function
8-bit	Asserted	A15–8	A23–16
8-bit	Deasserted	D7–0	A7–0
16-bit	Asserted	A7–0	A15–8
16-bit	Deasserted	D7–0	D15–8

## BOOT MODES

**Table 7. Boot Mode Selection**

BOOT_CFG1–0	Booting Mode
00	SPI Slave Boot
01	SPI Master Boot
10	Parallel Port Boot via EPROM
11	Reserved

## CORE INSTRUCTION RATE TO CLKIN RATIO MODES

For details on processor timing, see [Timing Specifications on Page 17](#).

**Table 8. Core Instruction Rate/CLKIN Ratio Selection**

CLK_CFG1–0	Core to CLKIN Ratio
00	6:1
01	32:1
10	16:1
11	Reserved

# ADSP-21362/ADSP-21363/ADSP-21364/ADSP-21365/ADSP-21366

## ADSP-2136x SPECIFICATIONS

### OPERATING CONDITIONS

Parameter <sup>1</sup>	Description	K Grade		B Grade		Y Grade		Unit
		Min	Max	Min	Max	Min	Max	
V <sub>DDINT</sub>	Internal (Core) Supply Voltage	1.14	1.26	1.14	1.26	0.95	1.05	V
A <sub>VDD</sub>	Analog (PLL) Supply Voltage	1.14	1.26	1.14	1.26	0.95	1.05	V
V <sub>DDEXT</sub>	External (I/O) Supply Voltage	3.13	3.47	3.13	3.47	3.13	3.47	V
V <sub>IH</sub> <sup>2</sup>	High Level Input Voltage @ V <sub>DDEXT</sub> = Max	2.0	V <sub>DDEXT</sub> + 0.5	2.0	V <sub>DDEXT</sub> + 0.5	2.0	V <sub>DDEXT</sub> + 0.5	V
V <sub>IL</sub> <sup>2</sup>	Low Level Input Voltage @ V <sub>DDEXT</sub> = Min	-0.5	+0.8	-0.5	+0.8	-0.5	+0.8	V
V <sub>IH_CLKIN</sub> <sup>3</sup>	High Level Input Voltage @ V <sub>DDEXT</sub> = Max	1.74	V <sub>DDEXT</sub> + 0.5	1.74	V <sub>DDEXT</sub> + 0.5	1.74	V <sub>DDEXT</sub> + 0.5	V
V <sub>IL_CLKIN</sub>	Low Level Input Voltage @ V <sub>DDEXT</sub> = Min	-0.5	+1.19	-0.5	+1.19	-0.5	+1.19	V
T <sub>J</sub> <sup>4,5</sup>	Junction Temperature 136-Ball CSP_BGA	0	+110	-40	+125	-40	+125	°C
T <sub>J</sub> <sup>4,5</sup>	Junction Temperature 144-Lead LQFP_EP	0	+110	-40	+125	-40	+125	°C

<sup>1</sup> Specifications subject to change without notice.

<sup>2</sup> Applies to input and bidirectional pins: AD15-0, FLAG3-0, DAI\_Px, SPICLK, MOSI, MISO,  $\overline{\text{SPIDS}}$ , BOOT\_CFGx, CLK\_CFGx,  $\overline{\text{RESET}}$ , TCK, TMS, TDI,  $\overline{\text{TRST}}$ .

<sup>3</sup> Applies to input pin CLKIN.

<sup>4</sup> See [Thermal Characteristics on Page 46](#) for information on thermal specifications.

<sup>5</sup> See *Estimating Power for the ADSP-21362 SHARC Processors (EE-277)* for further information.

### ELECTRICAL CHARACTERISTICS

Parameter <sup>1</sup>	Description	Test Conditions	Min	Max	Unit
V <sub>OH</sub> <sup>2</sup>	High Level Output Voltage	@ V <sub>DDEXT</sub> = Min, I <sub>OH</sub> = -1.0 mA <sup>3</sup>	2.4		V
V <sub>OL</sub> <sup>2</sup>	Low Level Output Voltage	@ V <sub>DDEXT</sub> = Min, I <sub>OL</sub> = 1.0 mA <sup>3</sup>		0.4	V
I <sub>IH</sub> <sup>4,5</sup>	High Level Input Current	@ V <sub>DDEXT</sub> = Max, V <sub>IN</sub> = V <sub>DDEXT</sub> Max		10	μA
I <sub>IL</sub> <sup>4</sup>	Low Level Input Current	@ V <sub>DDEXT</sub> = Max, V <sub>IN</sub> = 0 V		10	μA
I <sub>ILPU</sub> <sup>5</sup>	Low Level Input Current Pull-Up	@ V <sub>DDEXT</sub> = Max, V <sub>IN</sub> = 0 V		200	μA
I <sub>OZH</sub> <sup>6,7</sup>	Three-State Leakage Current	@ V <sub>DDEXT</sub> = Max, V <sub>IN</sub> = V <sub>DDEXT</sub> Max		10	μA
I <sub>OZL</sub> <sup>6</sup>	Three-State Leakage Current	@ V <sub>DDEXT</sub> = Max, V <sub>IN</sub> = 0 V		10	μA
I <sub>OZLPU</sub> <sup>7</sup>	Three-State Leakage Current Pull-Up	@ V <sub>DDEXT</sub> = Max, V <sub>IN</sub> = 0 V		200	μA
I <sub>DD-INTYP</sub> <sup>8,9</sup>	Supply Current (Internal)	t <sub>CLK</sub> = Min, V <sub>DDINT</sub> = Nom		800	mA
A <sub>I<sub>DD</sub></sub> <sup>10</sup>	Supply Current (Analog)	A <sub>VDD</sub> = Max		10	mA
C <sub>IN</sub> <sup>11,12</sup>	Input Capacitance	f <sub>IN</sub> = 1 MHz, T <sub>CASE</sub> = 25°C, V <sub>IN</sub> = 1.2 V		4.7	pF

<sup>1</sup> Specifications subject to change without notice.

<sup>2</sup> Applies to output and bidirectional pins: AD15-0,  $\overline{\text{RD}}$ ,  $\overline{\text{WR}}$ , ALE, FLAG3-0, DAI\_Px, SPICLK, MOSI, MISO,  $\overline{\text{EMU}}$ , TDO, CLKOUT, XTAL.

<sup>3</sup> See [Output Drive Currents on Page 45](#) for typical drive current capabilities.

<sup>4</sup> Applies to input pins:  $\overline{\text{SPIDS}}$ , BOOT\_CFGx, CLK\_CFGx, TCK,  $\overline{\text{RESET}}$ , CLKIN.

<sup>5</sup> Applies to input pins with 22.5 kΩ internal pull-ups:  $\overline{\text{TRST}}$ , TMS, TDI.

<sup>6</sup> Applies to three-stateable pins: FLAG3-0.

<sup>7</sup> Applies to three-stateable pins with 22.5 kΩ pull-ups: AD15-0, DAI\_Px, SPICLK,  $\overline{\text{EMU}}$ , MISO, MOSI.

<sup>8</sup> Typical internal current data reflects nominal operating conditions.

<sup>9</sup> See *Estimating Power for the ADSP-21362 SHARC Processors (EE-277)* for further information.

<sup>10</sup> Characterized, but not tested.

<sup>11</sup> Applies to all signal pins.

<sup>12</sup> Guaranteed, but not tested.

# ADSP-21362/ADSP-21363/ADSP-21364/ADSP-21365/ADSP-21366

## PACKAGE INFORMATION

The information presented in [Figure 5](#) provides details about the package branding for the ADSP-2136x processor. For a complete listing of product availability, see [Ordering Guide on Page 53](#).



Figure 5. Typical Package Brand

Table 9. Package Brand Information

Brand Key	Field Description
t	Temperature Range
pp	Package Type
Z	RoHS Compliant Option
cc	See Ordering Guide
vvvvv.x	Assembly Lot Code
n.n	Silicon Revision
yyww	Date Code

## ESD CAUTION



### ESD (electrostatic discharge) sensitive device.

Charged devices and circuit boards can discharge without detection. Although this product features patented or proprietary protection circuitry, damage may occur on devices subjected to high energy ESD. Therefore, proper ESD precautions should be taken to avoid performance degradation or loss of functionality.

## MAXIMUM POWER DISSIPATION

See *Estimating Power for the ADSP-21362 SHARC Processors (EE-277)* for detailed thermal and power information regarding maximum power dissipation. For information on package thermal specifications, see [Thermal Characteristics on Page 46](#).

## ABSOLUTE MAXIMUM RATINGS

Stresses greater than those listed in [Table 10](#) may cause permanent damage to the device. These are stress ratings only; functional operation of the device at these or any other conditions greater than those indicated in the operational sections of this specification is not implied. Exposure to absolute maximum rating conditions for extended periods may affect device reliability.

Table 10. Absolute Maximum Ratings

Parameter	Rating
Internal (Core) Supply Voltage ( $V_{DDINT}$ )	-0.3 V to +1.5 V
Analog (PLL) Supply Voltage ( $A_{VDD}$ )	-0.3 V to +1.5 V
External (I/O) Supply Voltage ( $V_{DDEXT}$ )	-0.3 V to +4.6 V
Input Voltage	-0.5 V to +3.8 V
Output Voltage Swing	-0.5 V to $V_{DDEXT} + 0.5$ V
Load Capacitance	200 pF
Storage Temperature Range	-65°C to +150°C
Junction Temperature Under Bias	125°C

## TIMING SPECIFICATIONS

The ADSP-2136x's internal clock (a multiple of CLKIN) provides the clock signal for timing internal memory, processor core, serial ports, and parallel port (as required for read/write strobes in asynchronous access mode). During reset, program the ratio between the processor's internal clock frequency and external (CLKIN) clock frequency with the CLK\_CFG1-0 pins (see [Table 8 on Page 15](#)). To determine switching frequencies for the serial ports, divide down the internal clock, using the programmable divider control of each port (DIVx for the serial ports).

The ADSP-2136x's internal clock switches at higher frequencies than the system input clock (CLKIN). To generate the internal clock, the processor uses an internal phase-locked loop (PLL). This PLL-based clocking minimizes the skew between the system clock (CLKIN) signal and the processor's internal clock (the clock source for the parallel port logic and I/O pads).

Note the definitions of various clock periods that are a function of CLKIN and the appropriate ratio control shown in [Table 11](#) and [Table 12](#).

In [Table 11](#), CCLK is defined as:

$$f_{CCLK} = (2 \times PLLM \times f_{INPUT}) \div (2 \times PLLN)$$

where:

$$f_{CCLK} = \text{CCLK frequency}$$

$$PLLM = \text{Multiplier value programmed}$$

$$PLLN = \text{Divider value programmed.}$$

Table 11. ADSP-2136x Clock Generation Operation

Timing Requirements	Description	Calculation
CLKIN	Input Clock	$1/t_{CK}$
CCLK	Core Clock	$1/t_{CCLK}$

Note the definitions of various clock periods shown in [Table 12](#) which are a function of CLKIN and the appropriate ratio control shown in [Table 11](#).

# ADSP-21362/ADSP-21363/ADSP-21364/ADSP-21365/ADSP-21366

**Table 12. Clock Periods**

Timing Requirements	Description <sup>1</sup>
$t_{CK}$	CLKIN Clock Period
$t_{CCLK}$	(Processor) Core Clock Period
$t_{PCLK}$	(Peripheral) Clock Period = $2 \times t_{CCLK}$
$t_{SCLK}$	Serial Port Clock Period = $(t_{CCLK}) \times SR$
$t_{SPICLK}$	SPI Clock Period = $(t_{CCLK}) \times SPIR$

<sup>1</sup> where:  
 SR = serial port-to-peripheral clock ratio (wide range, determined by SPORT CLKDIV)  
 SPIR = SPI-to-peripheral clock ratio (wide range, determined by SPIBAUD register)  
 SCLK = serial port clock  
 SPICLK = SPI clock

Figure 6 shows core to CLKIN relationships with external oscillator or crystal. The shaded divider/multiplier blocks denote where clock ratios can be set through hardware or software using the power management control register (PMCTL). For more information, see the *ADSP-2136x SHARC Processor Hardware Reference* and *Managing the Core PLL on Third-Generation SHARC Processors (EE-290)*.

Use the exact timing information given. Do not attempt to derive parameters from the addition or subtraction of others. While addition or subtraction would yield meaningful results for an individual device, the values given in this data sheet

reflect statistical variations and worst cases. Consequently, it is not meaningful to add parameters to derive longer times. See Figure 39 on Page 45 under Test Conditions for voltage reference levels.

Note that in the user application, the PLL multiplier value should be selected in such a way that the VCO frequency never exceeds 666 MHz. The VCO frequency is calculated as follows:

$$f_{VCO} = 2 \times PLLM \times f_{INPUT}$$

where:

$f_{VCO}$  is the VCO frequency.

$PLLM$  is the multiplier value programmed.

$f_{INPUT}$  is the input frequency to the PLL.

$f_{INPUT} = CLKIN$  when the input divider is disabled and

$f_{INPUT} = CLKIN \div 2$  when the input divider is enabled.

Timing Requirements apply to signals that are controlled by circuitry external to the processor, such as the data input for a read operation. Timing requirements guarantee that the processor operates correctly with other devices.

Switching Characteristics specify how the processor changes its signals. Circuitry external to the processor must be designed for compatibility with these signal characteristics. Switching characteristics describe what the processor will do in a given circumstance. Use switching characteristics to ensure that any timing requirement of a device connected to the processor (such

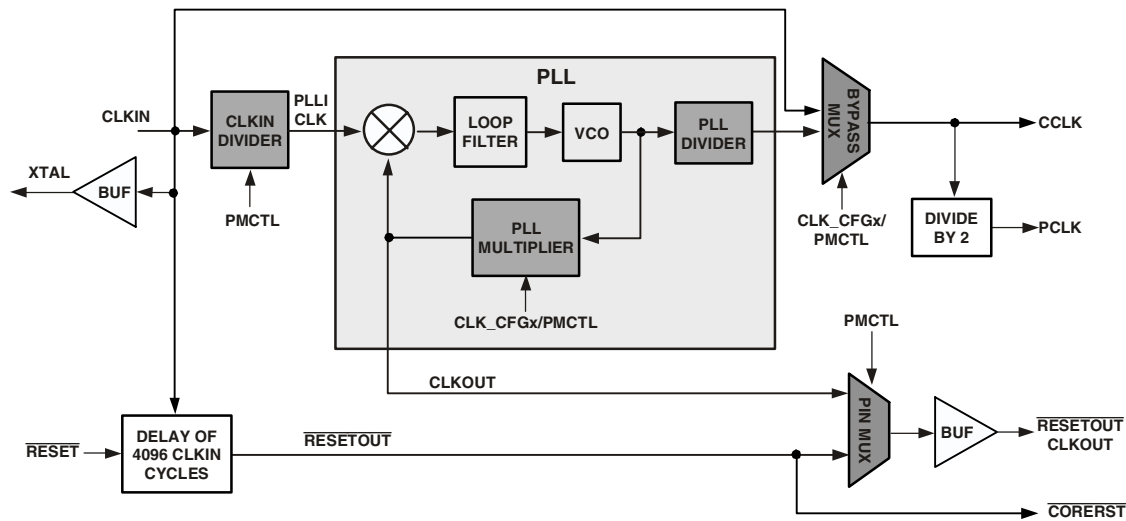

Figure 6. Core Clock and System Clock Relationship to CLKIN

## Power-Up Sequencing

The timing requirements for processor startup are given in [Table 13](#).

**Table 13. Power-Up Sequencing Timing Requirements (Processor Startup)**

Parameter		Min	Max	Unit
<i>Timing Requirements</i>				
$t_{RSTVDD}$	$\overline{RESET}$ Low Before $V_{DDINT}/V_{DDEXT}$ On	0		ns
$t_{VDDEVDD}$	$V_{DDINT}$ On Before $V_{DDEXT}$	-50	+200	ms
$t_{CLKVDD}^1$	CLKIN Valid After $V_{DDINT}/V_{DDEXT}$ Valid	0	200	ms
$t_{CLKRST}$	CLKIN Valid Before $\overline{RESET}$ Deasserted	$10^2$		$\mu$ s
$t_{PLLST}$	PLL Control Setup Before $\overline{RESET}$ Deasserted	20		$\mu$ s
<i>Switching Characteristic</i>				
$t_{CORERST}$	Core Reset Deasserted After $\overline{RESET}$ Deasserted	$4096t_{CK} + 2t_{CCLK}^{3,4}$		

<sup>1</sup> Valid  $V_{DDINT}/V_{DDEXT}$  assumes that the supplies are fully ramped to their 1.2 V rails and 3.3 V rails. Voltage ramp rates can vary from microseconds to hundreds of milliseconds depending on the design of the power supply subsystem.

<sup>2</sup> Assumes a stable CLKIN signal, after meeting worst-case start-up timing of crystal oscillators. Refer to your crystal oscillator manufacturer's data sheet for start-up time. Assume a 25 ms maximum oscillator start-up time if using the XTAL pin and internal oscillator circuit in conjunction with an external crystal.

<sup>3</sup> Applies after the power-up sequence is complete. Subsequent resets require a minimum of 4 CLKIN cycles for  $\overline{RESET}$  to be held low in order to properly initialize and propagate default states at all I/O pins.

<sup>4</sup> The 4096 cycle count depends on  $t_{SRST}$  specification in [Table 15](#). If setup time is not met, 1 additional CLKIN cycle may be added to the core reset time, resulting in 4097 cycles maximum.

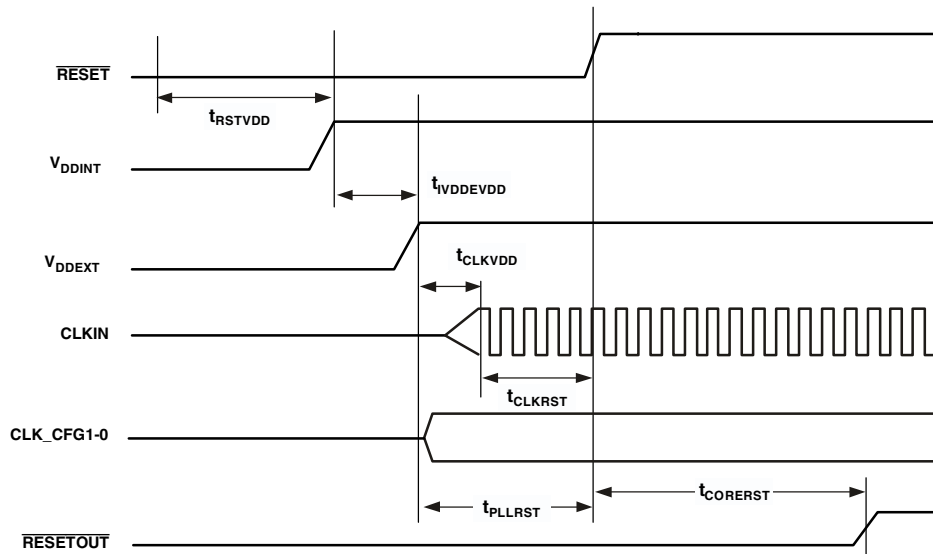

Figure 7. Power-Up Sequencing

# ADSP-21362/ADSP-21363/ADSP-21364/ADSP-21365/ADSP-21366

## Clock Input

Table 14. Clock Input

Parameter		333 MHz		Unit
		Min	Max	
<i>Timing Requirements</i>				
$t_{CK}$	CLKIN Period	18 <sup>1</sup>	100	ns
$t_{CKL}$	CLKIN Width Low	7.5 <sup>1</sup>		ns
$t_{CKH}$	CLKIN Width High	7.5 <sup>1</sup>		ns
$t_{CKRF}$	CLKIN Rise/Fall (0.4 V to 2.0 V)		3	ns
$t_{CCLK}^2$	CCLK Period	3.0 <sup>1</sup>	10	ns
$t_{CKJ}^{3,4}$	CLKIN Jitter Tolerance	-250	+250	ps

<sup>1</sup> Applies only for CLK\_CFG1-0 = 00 and default values for PLL control bits in PMCTL.

<sup>2</sup> Any changes to PLL control bits in the PMCTL register must meet core clock timing specification  $t_{CCLK}$ .

<sup>3</sup> Actual input jitter should be combined with ac specifications for accurate timing analysis.

<sup>4</sup> Jitter specification is maximum peak-to-peak time interval error (TIE) jitter.

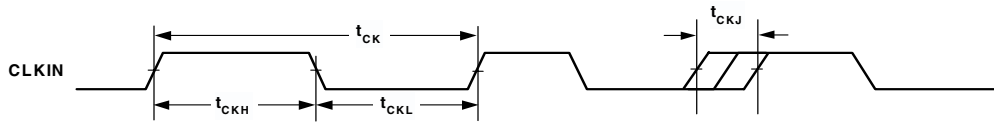
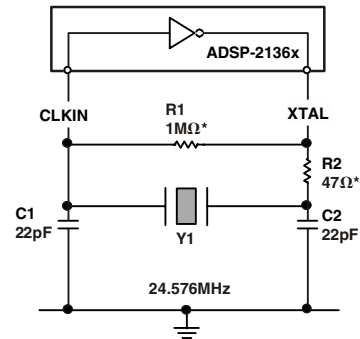

Figure 8. Clock Input

## Clock Signals

The ADSP-2136x can use an external clock or a crystal. See the CLKIN pin description in Table 4 on Page 12. The user application program can configure the ADSP-2136x to use its internal clock generator by connecting the necessary components to the CLKIN and XTAL pins. Figure 9 shows the component connections used for a fundamental frequency crystal operating in parallel mode.

Note that the clock rate is achieved using a 16.67 MHz crystal and a PLL multiplier ratio 16:1 (CCLK:CLKIN achieves a clock speed of 266.72 MHz). To achieve the full core clock rate, programs need to configure the multiplier bits in the PMCTL register.



R2 SHOULD BE CHOSEN TO LIMIT CRYSTAL DRIVE POWER. REFER TO CRYSTAL MANUFACTURER'S SPECIFICATIONS

\*TYPICAL VALUES

Figure 9. 333 MHz Operation (Fundamental Mode Crystal)

## Reset

**Table 15. Reset**

Parameter	Min	Max	Unit
<i>Timing Requirements</i>			
$t_{WRST}^1$ $\overline{\text{RESET}}$ Pulse Width Low	$4t_{CK}$		ns
$t_{SRST}$ $\overline{\text{RESET}}$ Setup Before CLKIN Low	8		ns

<sup>1</sup> Applies after the power-up sequence is complete. At power-up, the processor's internal phase-locked loop requires no more than 100  $\mu\text{s}$  while  $\overline{\text{RESET}}$  is low, assuming stable  $V_{DD}$  and CLKIN (not including start-up time of external clock oscillator).

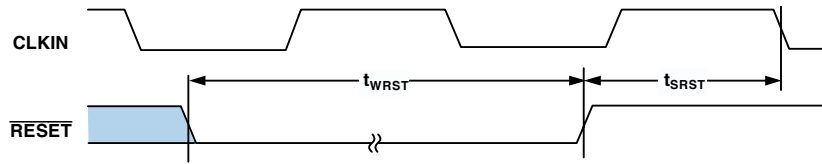

Figure 10. Reset

## Interrupts

The following timing specification applies to the FLAG0, FLAG1, and FLAG2 pins when they are configured as  $\overline{\text{IRQ0}}$ ,  $\overline{\text{IRQ1}}$ , and  $\overline{\text{IRQ2}}$  interrupts.

**Table 16. Interrupts**

Parameter	Min	Max	Unit
<i>Timing Requirement</i>			
$t_{IPW}$ $\overline{\text{IRQx}}$ Pulse Width	$2 \times t_{PCLK} + 2$		ns

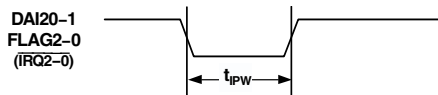

Figure 11. Interrupts

# ADSP-21362/ADSP-21363/ADSP-21364/ADSP-21365/ADSP-21366

## Core Timer

The following timing specification applies to FLAG3 when it is configured as the core timer (CTIMER).

Table 17. Core Timer

Parameter	Min	Max	Unit
<i>Switching Characteristic</i>			
$t_{WCTIM}$ CTIMER Pulse Width	$2 \times t_{PCLK} - 1$		ns

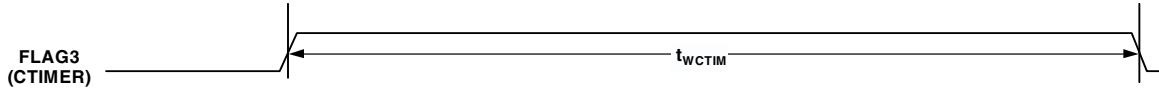

Figure 12. Core Timer

## Timer PWM\_OUT Cycle Timing

The following timing specification applies to Timer0, Timer1, and Timer2 in PWM\_OUT (pulse-width modulation) mode. Timer signals are routed to the DAI\_P20–1 pins through the SRU. Therefore, the timing specifications provided below are valid at the DAI\_P20–1 pins.

Table 18. Timer PWM\_OUT Timing

Parameter	Min	Max	Unit
<i>Switching Characteristic</i>			
$t_{PWMO}$ Timer Pulse Width Output	$2 t_{PCLK} - 1$	$2(2^{31} - 1) t_{PCLK}$	ns

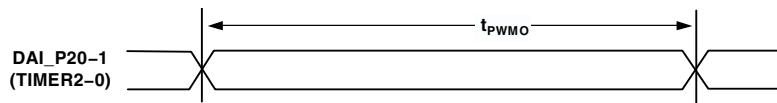

Figure 13. Timer PWM\_OUT Timing

### Timer WDT<sub>H</sub>\_CAP Timing

The following timing specification applies to Timer0, Timer1, and Timer2 in WDT<sub>H</sub>\_CAP (pulse width count and capture) mode. Timer signals are routed to the DAI\_P20-1 pins through the SRU. Therefore, the timing specification provided below are valid at the DAI\_P20-1 pins.

**Table 19. Timer Width Capture Timing**

Parameter	Min	Max	Unit
<i>Timing Requirement</i>			
$t_{PWI}$ Timer Pulse Width	$2 t_{PCLK}$	$2(2^{31} - 1) t_{PCLK}$	ns

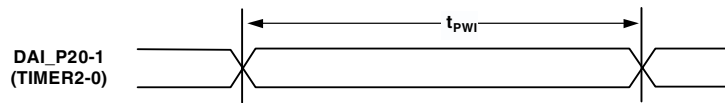

Figure 14. Timer Width Capture Timing

### DAI Pin to Pin Direct Routing

For direct pin connections only (for example, DAI\_PB01\_I to DAI\_PB02\_O).

**Table 20. DAI Pin to Pin Routing**

Parameter	Min	Max	Unit
<i>Timing Requirement</i>			
$t_{DPIO}$ Delay DAI Pin Input Valid to DAI Output Valid	1.5	10	ns

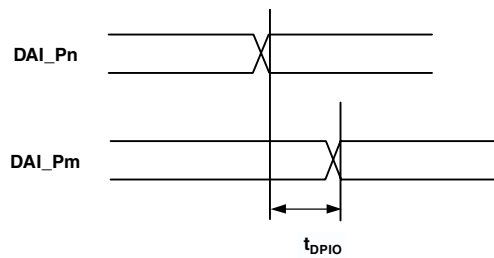

Figure 15. DAI Pin to Pin Direct Routing

# ADSP-21362/ADSP-21363/ADSP-21364/ADSP-21365/ADSP-21366

## Precision Clock Generator (Direct Pin Routing)

This timing is only valid when the SRU is configured such that the precision clock generator (PCG) takes its inputs directly from the DAI pins (via pin buffers) and sends its outputs directly to the DAI pins. For the other cases, where the PCG's

inputs and outputs are not directly routed to/from DAI pins (via pin buffers) there is no timing data available. All timing parameters and switching characteristics apply to external DAI pins (DAI\_P01 – DAI\_P20).

**Table 21. Precision Clock Generator (Direct Pin Routing)**

Parameter	K and B Grade		Y Grade	Unit
	Min	Max	Max	
<i>Timing Requirements</i>				
$t_{PCGIP}$ Input Clock Period	20			ns
$t_{STRIG}$ PCG Trigger Setup Before Falling Edge of PCG Input Clock	4.5			ns
$t_{HTRIG}$ PCG Trigger Hold After Falling Edge of PCG Input Clock	3			ns
<i>Switching Characteristics</i>				
$t_{DPCGIO}$ PCG Output Clock and Frame Sync Active Edge Delay After PCG Input Clock	2.5	10	10	ns
$t_{DTRIGCLK}$ PCG Output Clock Delay After PCG Trigger	$2.5 + (2.5 \times t_{PCGIP})$	$10 + (2.5 \times t_{PCGIP})$	$12 + (2.5 \times t_{PCGIP})$	ns
$t_{DTRIGFS}$ PCG Frame Sync Delay After PCG Trigger	$2.5 + ((2.5 - PH) \times t_{PCGIP})$	$10 + ((2.5 - PH) \times t_{PCGIP})$	$12 + ((2.5 - PH) \times t_{PCGIP})$	ns
$t_{PCGOP}^1$ Output Clock Period	$2 \times t_{PCGIP} - 1$			ns

PH = FSxPHASE. For more information, see the ADSP-2136x SHARC Processor Hardware Reference, "Precision Clock Generators" chapter.

<sup>1</sup>In normal mode,  $t_{PCGOP}(\text{min}) = 2 \times t_{PCGIP}$ .

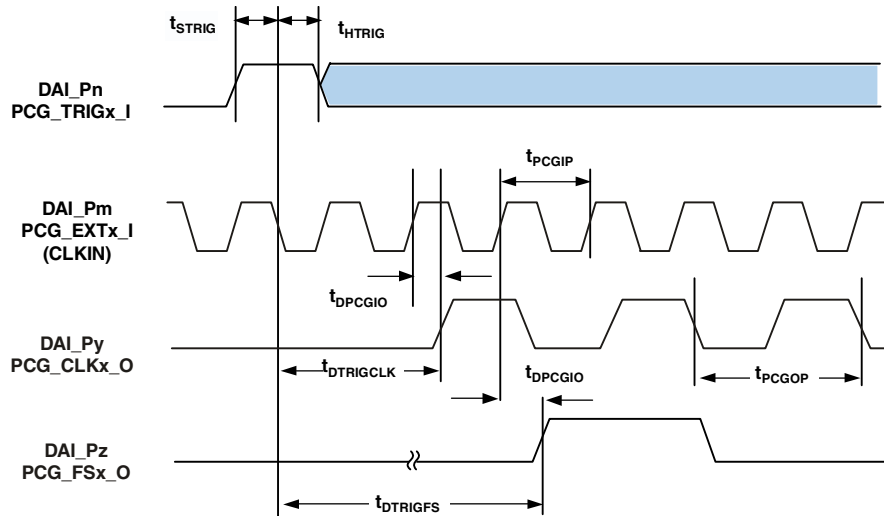

Figure 16. Precision Clock Generator (Direct Pin Routing)

## Flags

The timing specifications provided below apply to the FLAG3-0 and DAI\_P20-1 pins, the parallel port, and the serial peripheral interface (SPI). See [Table 4, “Pin Descriptions,” on Page 12](#) for more information on flag use.

**Table 22. Flags**

Parameter	Min	Max	Unit
<i>Timing Requirement</i>			
$t_{FIPW}$ FLAG3-0 IN Pulse Width	$2 \times t_{PCLK} + 3$		ns
<i>Switching Characteristic</i>			
$t_{FOPW}$ FLAG3-0 OUT Pulse Width	$2 \times t_{PCLK} - 1$		ns

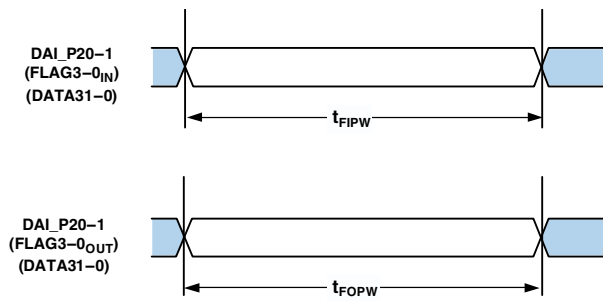

Figure 17. Flags

# ADSP-21362/ADSP-21363/ADSP-21364/ADSP-21365/ADSP-21366

## Memory Read—Parallel Port

Use these specifications for asynchronous interfacing to memories (and memory-mapped peripherals) when the ADSP-2136x is accessing external memory space.

**Table 23. 8-Bit Memory Read Cycle**

Parameter	K and B Grade		Y Grade		Unit	
	Min	Max	Min	Max		
<i>Timing Requirements</i>						
$t_{DRS}$	AD7–0 Data Setup Before $\overline{RD}$ High		3.3		4.5	ns
$t_{DRH}$	AD7–0 Data Hold After $\overline{RD}$ High		0		0	ns
$t_{DAD}$	AD15–8 Address to AD7–0 Data Valid			$D + t_{PCLK} - 5.0$		$D + t_{PCLK} - 5.0$ ns
<i>Switching Characteristics</i>						
$t_{ALEW}$	ALE Pulse Width		$2 \times t_{PCLK} - 2.0$		$2 \times t_{PCLK} - 2.0$	ns
$t_{ADAS}^1$	AD15–0 Address Setup Before ALE Deasserted		$t_{PCLK} - 2.5$		$t_{PCLK} - 2.5$	ns
$t_{RRH}$	Delay Between $\overline{RD}$ Rising Edge to Next Falling Edge		$H + t_{PCLK} - 1.4$		$H + t_{PCLK} - 1.4$	ns
$t_{ALERW}$	ALE Deasserted to Read Asserted		$2 \times t_{PCLK} - 3.8$		$2 \times t_{PCLK} - 3.8$	ns
$t_{RWALE}$	Read Deasserted to ALE Asserted		$F + H + 0.5$		$F + H + 0.5$	ns
$t_{ADAH}^1$	AD15–0 Address Hold After ALE Deasserted		$t_{PCLK} - 2.3$		$t_{PCLK} - 2.3$	ns
$t_{ALEHZ}^1$	ALE Deasserted to AD7–0 Address in High-Z		$t_{PCLK}$	$t_{PCLK} + 3.0$	$t_{PCLK}$	$t_{PCLK} + 3.8$ ns
$t_{RW}$	$\overline{RD}$ Pulse Width		$D - 2.0$		$D - 2.0$	ns
$t_{RDDR}$	AD7–0 ALE Address Drive After Read High		$F + H + t_{PCLK} - 2.3$		$F + H + t_{PCLK} - 2.3$	ns
$t_{ADRH}$	AD15–8 Address Hold After $\overline{RD}$ High		H		H	ns
$t_{DAWH}$	AD15–8 Address to $\overline{RD}$ High		$D + t_{PCLK} - 4.0$		$D + t_{PCLK} - 4.0$	ns

D = (data cycle duration = the value set by the PPDUR Bits (5–1) in the PPCTL register)  $\times t_{PCLK}$

H =  $t_{PCLK}$  (if a hold cycle is specified, else H = 0)

F =  $7 \times t_{PCLK}$  (if FLASH\_MODE is set, else F = 0)

$t_{PCLK}$  = (peripheral) clock period =  $2 \times t_{CCLK}$

<sup>1</sup> On reset, ALE is an active high cycle. However, it can be configured by software to be active low.

# ADSP-21362/ADSP-21363/ADSP-21364/ADSP-21365/ADSP-21366

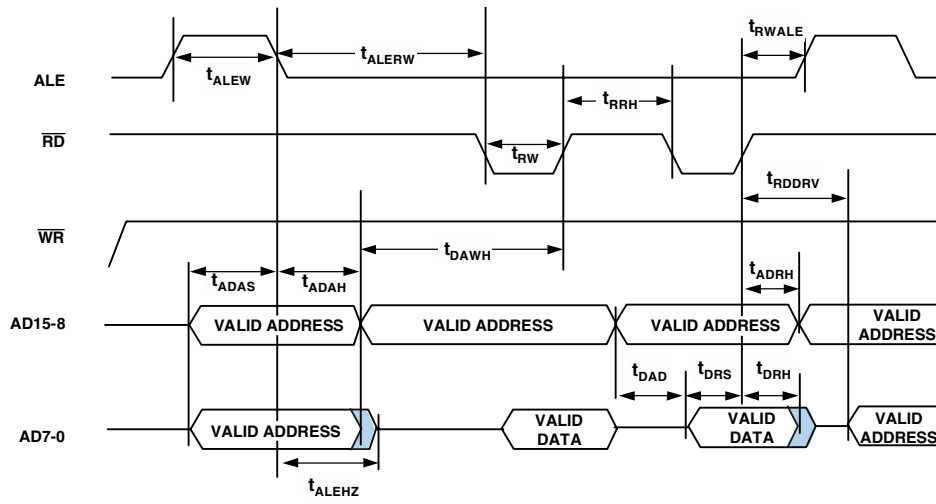

NOTE: MEMORY READS ALWAYS OCCUR IN GROUPS OF FOUR BETWEEN ALE CYCLES. THIS FIGURE ONLY SHOWS TWO MEMORY READS IN ORDER TO PROVIDE THE NECESSARY TIMING INFORMATION.

Figure 18. Read Cycle for 8-Bit Memory Timing

# ADSP-21362/ADSP-21363/ADSP-21364/ADSP-21365/ADSP-21366

Table 24. 16-Bit Memory Read Cycle

Parameter	K and B Grade		Y Grade		Unit
	Min	Max	Min	Max	
<i>Timing Requirements</i>					
$t_{DRS}$	AD15-0 Data Setup Before $\overline{RD}$ High		3.3	4.5	ns
$t_{DRH}$	AD15-0 Data Hold After $\overline{RD}$ High		0	0	ns
<i>Switching Characteristics</i>					
$t_{ALEW}$	ALE Pulse Width		$2 \times t_{PCLK} - 2.0$	$2 \times t_{PCLK} - 2.0$	ns
$t_{ADAS}^1$	AD15-0 Address Setup Before ALE Deasserted		$t_{PCLK} - 2.5$	$t_{PCLK} - 2.5$	ns
$t_{ALERW}$	ALE Deasserted to Read Asserted		$2 \times t_{PCLK} - 3.8$	$2 \times t_{PCLK} - 3.8$	ns
$t_{RRH}^2$	Delay Between $\overline{RD}$ Rising Edge to Next Falling Edge		$H + t_{PCLK} - 1.4$	$H + t_{PCLK} - 1.4$	ns
$t_{RWALE}$	Read Deasserted to ALE Asserted		$F + H + 0.5$	$F + H + 0.5$	ns
$t_{RDDR}$	ALE Address Drive After Read High		$F + H + t_{PCLK} - 2.3$	$F + H + t_{PCLK} - 2.3$	ns
$t_{ADAH}^1$	AD15-0 Address Hold After ALE Deasserted		$t_{PCLK} - 2.3$	$t_{PCLK} - 2.3$	ns
$t_{ALEHZ1}$	ALE Deasserted to Address/Data15-0 in High-Z		$t_{PCLK}$	$t_{PCLK} + 3.0$	ns
$t_{RW}$	$\overline{RD}$ Pulse Width		$D - 2.0$	$D - 2.0$	ns

D = (data cycle duration = the value set by the PPDUR Bits (5-1) in the PPCTL register)  $\times t_{PCLK}$

H =  $t_{PCLK}$  (if a hold cycle is specified, else H = 0)

F =  $7 \times t_{PCLK}$  (if FLASH\_MODE is set, else F = 0)

$t_{PCLK}$  = (peripheral) clock period =  $2 \times t_{CCLK}$

<sup>1</sup> On reset, ALE is an active high cycle. However, it can be configured by software to be active low.

<sup>2</sup> This parameter is only available when in EMPP = 0 mode.

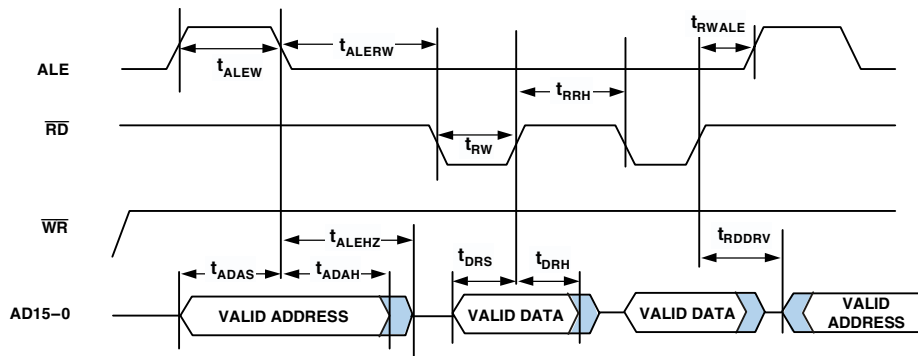

NOTE: FOR 16-BIT MEMORY READS, WHEN EMPP  $\neq$  0, ONLY ONE  $\overline{RD}$  PULSE OCCURS BETWEEN ALE CYCLES. WHEN EMPP = 0, MULTIPLE  $\overline{RD}$  PULSES OCCUR BETWEEN ALE CYCLES. FOR COMPLETE INFORMATION, SEE THE ADSP-2136X SHARC PROCESSOR HARDWARE REFERENCE.

Figure 19. Read Cycle for 16-Bit Memory Timing

# ADSP-21362/ADSP-21363/ADSP-21364/ADSP-21365/ADSP-21366

## Memory Write—Parallel Port

Use these specifications for asynchronous interfacing to memories (and memory-mapped peripherals) when the ADSP-2136x is accessing external memory space.

**Table 25. 8-Bit Memory Write Cycle**

Parameter		K and B Grade	Y Grade	Unit
		Min	Min	
<i>Switching Characteristics:</i>				
$t_{ALEW}$	ALE Pulse Width	$2 \times t_{PCLK} - 2.0$	$2 \times t_{PCLK} - 2.0$	ns
$t_{ADAS}^1$	AD15–0 Address Setup Before ALE Deasserted	$t_{PCLK} - 2.8$	$t_{PCLK} - 2.8$	ns
$t_{ALERW}$	ALE Deasserted to Write Asserted	$2 \times t_{PCLK} - 3.8$	$2 \times t_{PCLK} - 3.8$	ns
$t_{RWALE}$	Write Deasserted to ALE Asserted	H + 0.5	H + 0.5	ns
$t_{WRH}$	Delay Between $\overline{WR}$ Rising Edge to Next $\overline{WR}$ Falling Edge	$F + H + t_{PCLK} - 2.3$	$F + H + t_{PCLK} - 2.3$	ns
$t_{ADAH}^1$	AD15–0 Address Hold After ALE Deasserted	$t_{PCLK} - 0.5$	$t_{PCLK} - 0.5$	ns
$t_{WW}$	$\overline{WR}$ Pulse Width	$D - F - 2.0$	$D - F - 2.0$	ns
$t_{ADWL}$	AD15–8 Address to $\overline{WR}$ Low	$t_{PCLK} - 2.8$	$t_{PCLK} - 3.5$	ns
$t_{ADWH}$	AD15–8 Address Hold After $\overline{WR}$ High	H	H	ns
$t_{DWS}$	AD7–0 Data Setup Before $\overline{WR}$ High	$D - F + t_{PCLK} - 4.0$	$D - F + t_{PCLK} - 4.0$	ns
$t_{DWH}$	AD7–0 Data Hold After $\overline{WR}$ High	H	H	ns
$t_{DAWH}$	AD15–8 Address to $\overline{WR}$ High	$D - F + t_{PCLK} - 4.0$	$D - F + t_{PCLK} - 4.0$	ns

D = (data cycle duration = the value set by the PPDUR Bits (5–1) in the PPCTL register)  $\times t_{PCLK}$ .

H =  $t_{PCLK}$  (if a hold cycle is specified, else H = 0)

F =  $7 \times t_{PCLK}$  (if FLASH\_MODE is set, else F = 0). If FLASH\_MODE is set, D must be  $\geq 9 \times t_{PCLK}$ .

$t_{PCLK}$  = (peripheral) clock period =  $2 \times t_{CLK}$

<sup>1</sup>On reset, ALE is an active high cycle. However, it can be configured by software to be active low.

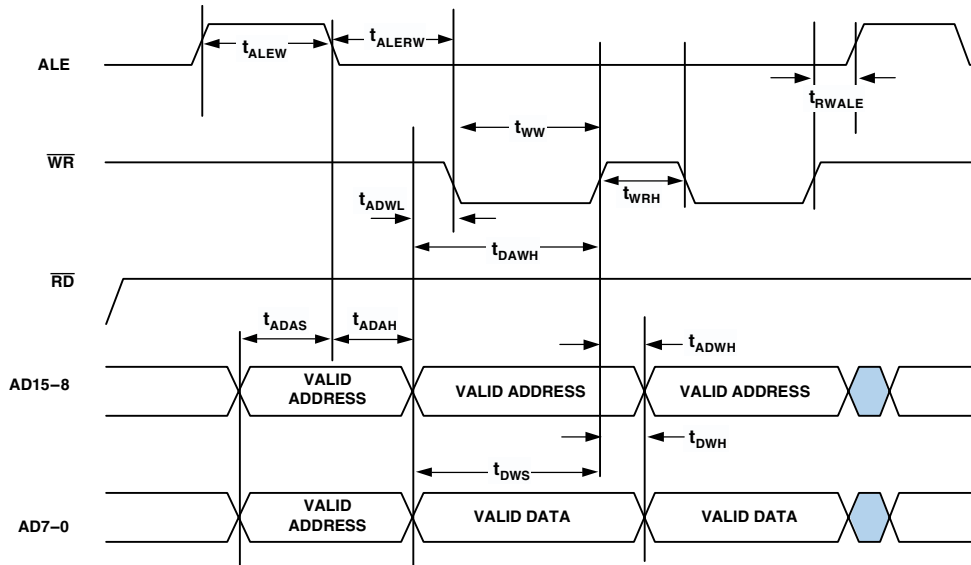

NOTE: MEMORY WRITES ALWAYS OCCUR IN GROUPS OF FOUR BETWEEN ALE CYCLES. THIS FIGURE ONLY SHOWS TWO MEMORY WRITES IN ORDER TO PROVIDE THE NECESSARY TIMING INFORMATION.

Figure 20. Write Cycle for 8-Bit Memory Timing

# ADSP-21362/ADSP-21363/ADSP-21364/ADSP-21365/ADSP-21366

Table 26. 16-Bit Memory Write Cycle

Parameter		K and B Grade	Y Grade	Unit
		Min	Min	
<i>Switching Characteristics</i>				
$t_{ALEW}$	ALE Pulse Width	$2 \times t_{PCLK} - 2.0$	$2 \times t_{PCLK} - 2.0$	ns
$t_{ADAS}^1$	AD15-0 Address Setup Before ALE Deasserted	$t_{PCLK} - 2.5$	$t_{PCLK} - 2.5$	ns
$t_{ALERW}$	ALE Deasserted to Write Asserted	$2 \times t_{PCLK} - 3.8$	$2 \times t_{PCLK} - 3.8$	ns
$t_{RWALE}$	Write Deasserted to ALE Asserted	H + 0.5	H + 0.5	ns
$t_{WRH}^2$	Delay Between $\overline{WR}$ Rising Edge to Next $\overline{WR}$ Falling Edge	$F + H + t_{PCLK} - 2.3$	$F + H + t_{PCLK} - 2.3$	ns
$t_{ADAH}^1$	AD15-0 Address Hold After ALE Deasserted	$t_{PCLK} - 2.3$	$t_{PCLK} - 2.3$	ns
$t_{WW}$	$\overline{WR}$ Pulse Width	D - F - 2.0	D - F - 2.0	ns
$t_{DWS}$	AD15-0 Data Setup Before $\overline{WR}$ High	D - F + $t_{PCLK} - 4.0$	D - F + $t_{PCLK} - 4.0$	ns
$t_{DWH}$	AD15-0 Data Hold After $\overline{WR}$ High	H	H	ns

D = (data cycle duration = the value set by the PPDUR Bits (5-1) in the PPCTL register)  $\times t_{PCLK}$ .

H =  $t_{PCLK}$  (if a hold cycle is specified, else H = 0)

F =  $7 \times t_{PCLK}$  (if FLASH\_MODE is set, else F = 0). If FLASH\_MODE is set, D must be  $\geq 9 \times t_{PCLK}$ .

$t_{PCLK}$  = (peripheral) clock period =  $2 \times t_{CCLK}$

<sup>1</sup>On reset, ALE is an active high cycle. However, it can be configured by software to be active low.

<sup>2</sup>This parameter is only available when in EMPP = 0 mode.

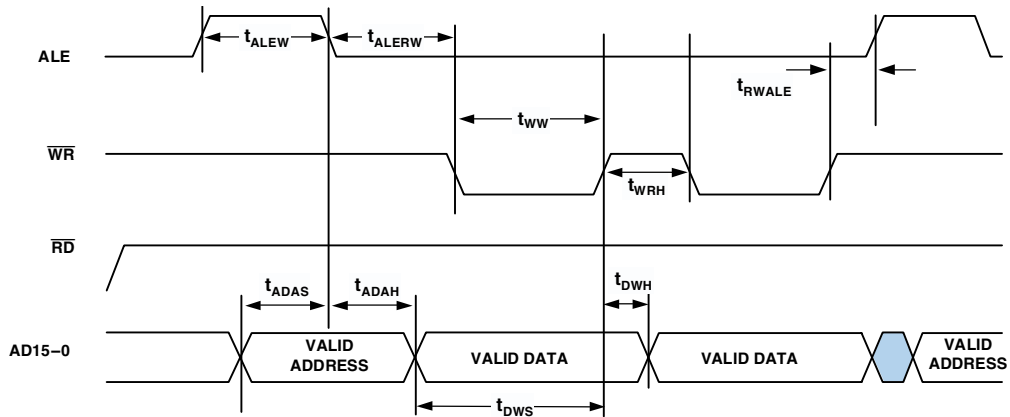

NOTE: FOR 16-BIT MEMORY WRITES, WHEN EMPP  $\neq$  0, ONLY ONE  $\overline{WR}$  PULSE OCCURS BETWEEN ALE CYCLES. WHEN EMPP = 0, MULTIPLE  $\overline{WR}$  PULSES OCCUR BETWEEN ALE CYCLES. FOR COMPLETE INFORMATION, SEE THE ADSP-2136X SHARC PROCESSOR HARDWARE REFERENCE.

Figure 21. Write Cycle for 16-Bit Memory Timing

# ADSP-21362/ADSP-21363/ADSP-21364/ADSP-21365/ADSP-21366

## Serial Ports

To determine whether communication is possible between two devices at clock speed  $n$ , the following specifications must be confirmed: 1) frame sync delay and frame sync setup and hold, 2) data delay and data setup and hold, and 3) SCLK width.

Serial port signals (SCLK, FS, data channel A, data channel B) are routed to the DAI\_P20–1 pins using the SRU. Therefore, the timing specifications provided below are valid at the DAI\_P20–1 pins.

**Table 27. Serial Ports—External Clock**

Parameter	K and B Grade		Y Grade	Unit
	Min	Max	Max	
<i>Timing Requirements</i>				
$t_{SFSE}^1$	FS Setup Before SCLK (Externally Generated FS in Either Transmit or Receive Mode)			ns
$t_{HFSE}^1$	FS Hold After SCLK (Externally Generated FS in Either Transmit or Receive Mode)			ns
$t_{SDRE}^1$	Receive Data Setup Before Receive SCLK			ns
$t_{HDRE}^1$	Receive Data Hold After SCLK			ns
$t_{SCLKW}$	SCLK Width			ns
$t_{SCLK}$	SCLK Period			ns
<i>Switching Characteristics</i>				
$t_{DFSE}^2$	FS Delay After SCLK (Internally Generated FS in Either Transmit or Receive Mode)		9.5	11
$t_{HOFSE}^2$	FS Hold After SCLK (Internally Generated FS in Either Transmit or Receive Mode)		2	ns
$t_{DDTE}^2$	Transmit Data Delay After Transmit SCLK		9.5	11
$t_{HDTE}^2$	Transmit Data Hold After Transmit SCLK		2	ns

<sup>1</sup>Referenced to sample edge.

<sup>2</sup>Referenced to drive edge.

**Table 28. Serial Ports—Internal Clock**

Parameter	K and B Grade		Y Grade	Unit
	Min	Max	Max	
<i>Timing Requirements</i>				
$t_{SFSI}^1$	FS Setup Before SCLK (Externally Generated FS in Either Transmit or Receive Mode)			ns
$t_{HFSI}^1$	FS Hold After SCLK (Externally Generated FS in Either Transmit or Receive Mode)			ns
$t_{SDRI}^1$	Receive Data Setup Before SCLK			ns
$t_{HDRI}^1$	Receive Data Hold After SCLK			ns
<i>Switching Characteristics</i>				
$t_{DFSI}^2$	FS Delay After SCLK (Internally Generated FS in Transmit Mode)		3	3.5
$t_{HOFSI}^2$	FS Hold After SCLK (Internally Generated FS in Transmit Mode)		-1.0	ns
$t_{DFSIR}^2$	FS Delay After SCLK (Internally Generated FS in Receive Mode)		8	9.5
$t_{HOF SIR}^2$	FS Hold After SCLK (Internally Generated FS in Receive Mode)		-1.0	ns
$t_{DDTI}^2$	Transmit Data Delay After SCLK		3	4.0
$t_{HDTI}^2$	Transmit Data Hold After SCLK		-1.0	ns
$t_{SCLKIW}$	Transmit or Receive SCLK Width		$0.5t_{SCLK} - 2$	$0.5t_{SCLK} + 2$

<sup>1</sup>Referenced to the sample edge.

<sup>2</sup>Referenced to drive edge.

# ADSP-21362/ADSP-21363/ADSP-21364/ADSP-21365/ADSP-21366

**Table 29. Serial Ports—Enable and Three-State**

Parameter	K and B Grade		Y Grade	Unit
	Min	Max	Max	
<i>Switching Characteristics</i>				
$t_{DDTEN}^1$	Data Enable from External Transmit SCLK			ns
$t_{DDTE}^1$	Data Disable from External Transmit SCLK		8.5	ns
$t_{DDTIN}^1$	Data Enable from Internal Transmit SCLK			ns

<sup>1</sup>Referenced to drive edge.

**Table 30. Serial Ports—External Late Frame Sync**

Parameter	K and B Grade		Y Grade	Unit
	Min	Max	Max	
<i>Switching Characteristics</i>				
$t_{DDTLFSE}^1$	Data Delay from Late External Transmit FS or External Receive FS with MCE = 1, MFD = 0		10.5	ns
$t_{DDTENFS}^1$	Data Enable for MCE = 1, MFD = 0			ns

<sup>1</sup>The  $t_{DDTLFSE}$  and  $t_{DDTENFS}$  parameters apply to left-justified sample pair as well as DSP serial mode, and MCE = 1, MFD = 0.

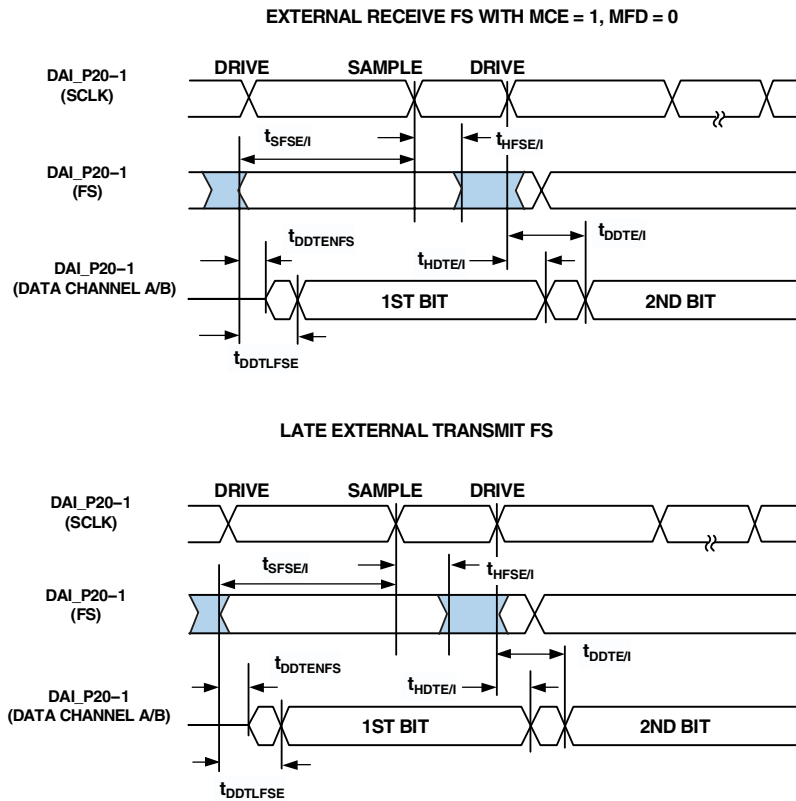

NOTE: SERIAL PORT SIGNALS (SCLK, FS, DATA CHANNEL A/B) ARE ROUTED TO THE DAI\_P20-1 PINS USING THE SRU. THE TIMING SPECIFICATIONS PROVIDED HERE ARE VALID AT THE DAI\_P20-1 PINS.

Figure 22. External Late Frame Sync<sup>1</sup>

<sup>1</sup>This figure reflects changes made to support left-justified sample pair mode.

# ADSP-21362/ADSP-21363/ADSP-21364/ADSP-21365/ADSP-21366

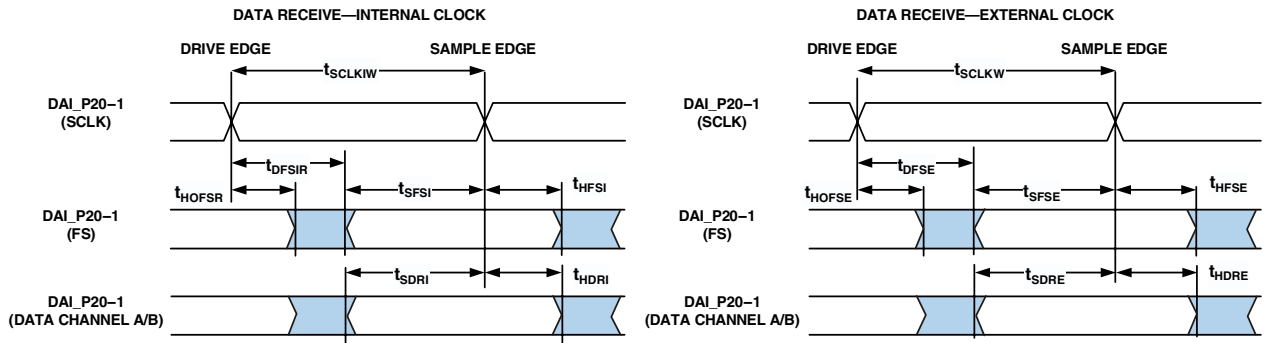

NOTE: EITHER THE RISING EDGE OR FALLING EDGE OF SCLK (EXTERNAL), SCLK (INTERNAL) CAN BE USED AS THE ACTIVE SAMPLING EDGE.

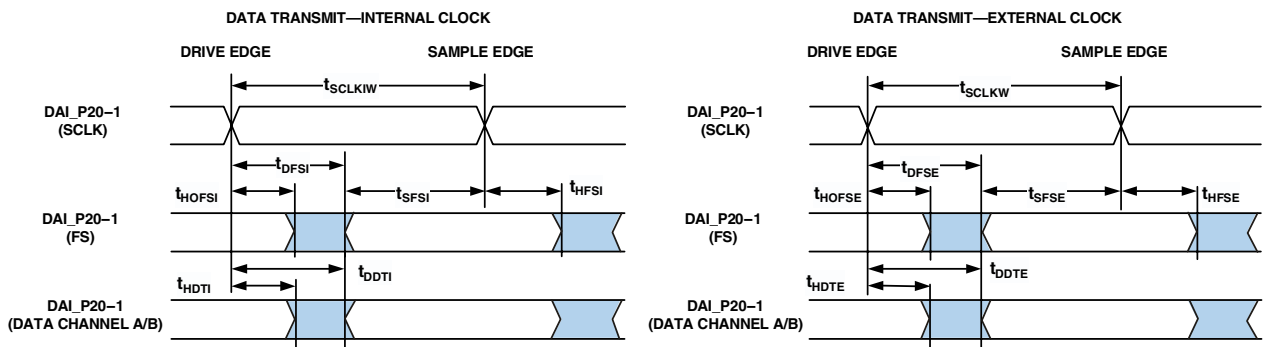

NOTE: EITHER THE RISING EDGE OR FALLING EDGE OF SCLK (EXTERNAL), SCLK (INTERNAL) CAN BE USED AS THE ACTIVE SAMPLING EDGE.

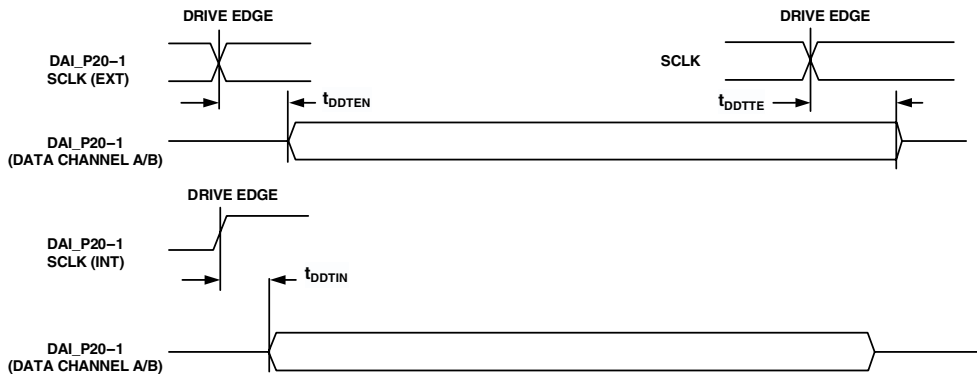

Figure 23. Serial Ports

# ADSP-21362/ADSP-21363/ADSP-21364/ADSP-21365/ADSP-21366

## Input Data Port (IDP)

The timing requirements for the IDP are given in [Table 31](#). IDP signals (SCLK, FS, SDATA) are routed to the DAI\_P20-1 pins using the SRU. Therefore, the timing specifications provided below are valid at the DAI\_P20-1 pins.

**Table 31. IDP**

Parameter	Min	Max	Unit
<i>Timing Requirements</i>			
$t_{SISFS}^1$			ns
FS Setup Before SCLK Rising Edge	3		
$t_{SIHFS}^1$			ns
FS Hold After SCLK Rising Edge	3		
$t_{SISD}^1$			ns
SDATA Setup Before SCLK Rising Edge	3		
$t_{SIHD}^1$			ns
SDATA Hold After SCLK Rising Edge	3		
$t_{IDPCLKW}$			ns
Clock Width	9		
$t_{IDPCLK}$			ns
Clock Period	24		

<sup>1</sup> DATA, SCLK, FS can come from any of the DAI pins. SCLK and FS can also come via PCG or SPORTs. PCG's input can be either CLKIN or any of the DAI pins.

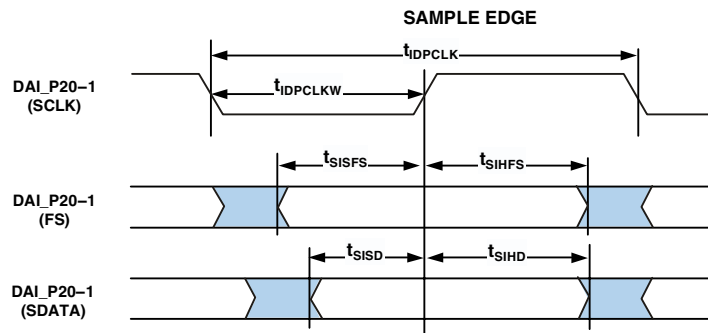

Figure 24. IDP Master Timing

# ADSP-21362/ADSP-21363/ADSP-21364/ADSP-21365/ADSP-21366

## Parallel Data Acquisition Port (PDAP)

The timing requirements for the PDAP are provided in [Table 32](#). PDAP is the parallel mode operation of Channel 0 of the IDP. For details on the operation of the IDP, see the IDP chapter of the *ADSP-2136x SHARC Processor Hardware*

*Reference.* Note that the most significant 16 bits of external PDAP data can be provided through either the parallel port AD15–0 or the DAI\_P20–5 pins. The remaining 4 bits can only be sourced through DAI\_P4–1. The timing below is valid at the DAI\_P20–1 pins or at the AD15–0 pins.

**Table 32. Parallel Data Acquisition Port (PDAP)**

Parameter		Min	Max	Unit
<i>Timing Requirements</i>				
$t_{SPCKEN}^1$	PDAP_CLKEN Setup Before PDAP_CLK Sample Edge	2.5		ns
$t_{HPCKEN}^1$	PDAP_CLKEN Hold After PDAP_CLK Sample Edge	2.5		ns
$t_{PDSD}^1$	PDAP_DAT Setup Before SCLK PDAP_CLK Sample Edge	3.0		ns
$t_{PDHD}^1$	PDAP_DAT Hold After SCLK PDAP_CLK Sample Edge	2.5		ns
$t_{PDCLKW}$	Clock Width	7.0		ns
$t_{PDCLK}$	Clock Period	24		ns
<i>Switching Characteristics</i>				
$t_{PDHLDD}$	Delay of PDAP Strobe After Last PDAP_CLK Capture Edge for a Word	$2 \times t_{PCLK} - 1$		ns
$t_{PDSTRB}$	PDAP Strobe Pulse Width	$2 \times t_{PCLK} - 1.5$		ns

<sup>1</sup> Source pins of DATA are AD7–0, DATA7–0, or DAI pins. Source pins for SCLK and FS are: 1) DAI pins, 2) CLKIN through PCG, or 3) DAI pins through PCG.

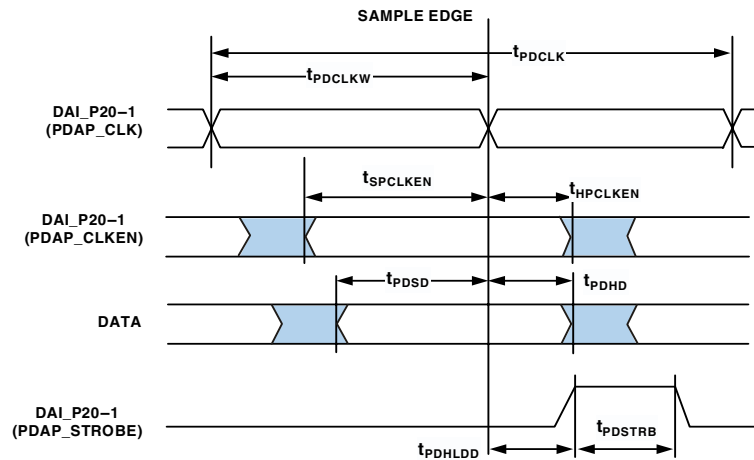

Figure 25. PDAP Timing

# ADSP-21362/ADSP-21363/ADSP-21364/ADSP-21365/ADSP-21366

## Pulse-Width Modulation Generators

Table 33. PWM Timing

Parameter	Min	Max	Unit
<i>Switching Characteristics</i>			
$t_{PWW}$ PWM Output Pulse Width	$t_{PCLK} - 2$	$(2^{16} - 2) \times t_{PCLK} - 2$	ns
$t_{PWMP}$ PWM Output Period	$2 \times t_{PCLK} - 1.5$	$(2^{16} - 1) \times t_{PCLK}$	ns

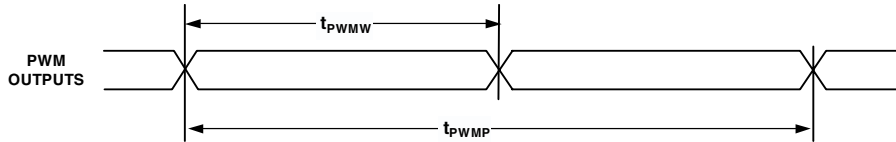

Figure 26. PWM Timing

## Sample Rate Converter—Serial Input Port

The SRC input signals (SCLK, FS, and SDATA) are routed from the DAI\_P20-1 pins using the SRU. Therefore, the timing specifications provided in Table 34 are valid at the DAI\_P20-1 pins. This feature is not available on the ADSP-21363 models.

Table 34. SRC, Serial Input Port

Parameter	Min	Max	Unit
<i>Timing Requirements</i>			
$t_{SRCFS}^1$ FS Setup Before SCLK Rising Edge	3		ns
$t_{SRCHFS}^1$ FS Hold After SCLK Rising Edge	3		ns
$t_{SRCSD}^1$ SDATA Setup Before SCLK Rising Edge	3		ns
$t_{SRCHD}^1$ SDATA Hold After SCLK Rising Edge	3		ns
$t_{SRCCLKW}$ Clock Width	36		ns
$t_{SRCCLK}$ Clock Period	80		ns

<sup>1</sup> DATA, SCLK, FS can come from any of the DAI pins. SCLK and FS can also come via PCG or SPORTs. PCG's input can be either CLKIN or any of the DAI pins.

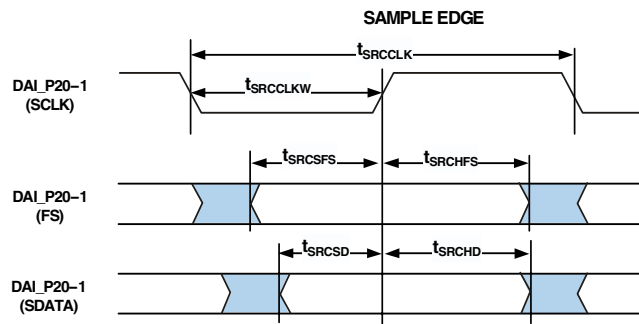

Figure 27. SRC Serial Input Port Timing

## Sample Rate Converter—Serial Output Port

For the serial output port, the frame-sync is an input and should meet setup and hold times with regard to SCLK on the output port. The serial data output, SDATA, has a hold time and delay specification with regard to SCLK. Note that SCLK rising edge is the sampling edge and the falling edge is the drive edge.

**Table 35. SRC, Serial Output Port**

Parameter	K and B Grade		Y Grade	Unit
	Min	Max	Max	
<i>Timing Requirements</i>				
$t_{\text{SRCFS}}^1$ FS Setup Before SCLK Rising Edge	3			ns
$t_{\text{SRCHF}}^1$ FS Hold After SCLK Rising Edge	3			ns
<i>Switching Characteristics</i>				
$t_{\text{SRCTDD}}^1$ Transmit Data Delay After SCLK Falling Edge		10.5	12.5	ns
$t_{\text{SRCTDH}}^1$ Transmit Data Hold After SCLK Falling Edge	2			ns

<sup>1</sup> DATA, SCLK, FS can come from any of the DAI pins. SCLK and FS can also come via PCG or SPORTs. PCG's input can be either CLKIN or any of the DAI pins.

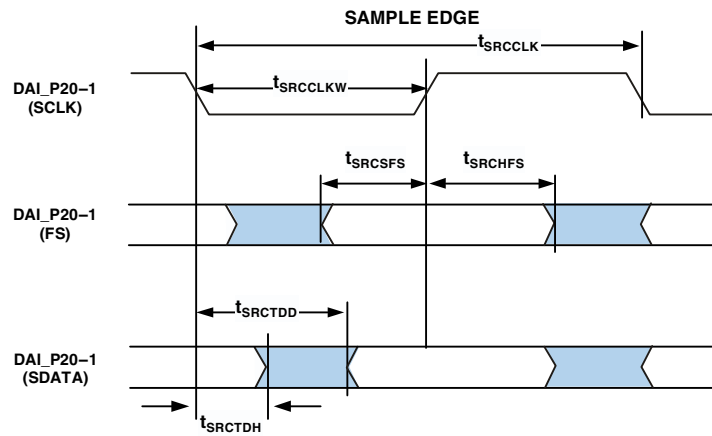

Figure 28. SRC Serial Output Port Timing

# ADSP-21362/ADSP-21363/ADSP-21364/ADSP-21365/ADSP-21366

## S/PDIF Transmitter

Serial data input to the S/PDIF transmitter can be formatted as left-justified, I<sup>2</sup>S, or right-justified with word widths of 16, 18, 20, or 24 bits. The following sections provide timing for the transmitter. This feature is not available on the ADSP-21363 models.

## S/PDIF Transmitter—Serial Input Waveforms

Figure 29 shows the right-justified mode. LRCLK is HI for the left channel and LO for the right channel. Data is valid on the rising edge of SCLK. The MSB is delayed 12-bit clock periods (in 20-bit output mode) or 16-bit clock periods (in 16-bit output mode) from an LRCLK transition, so that when there are 64 SCLK periods per LRCLK period, the LSB of the data will be right-justified to the next LRCLK transition.

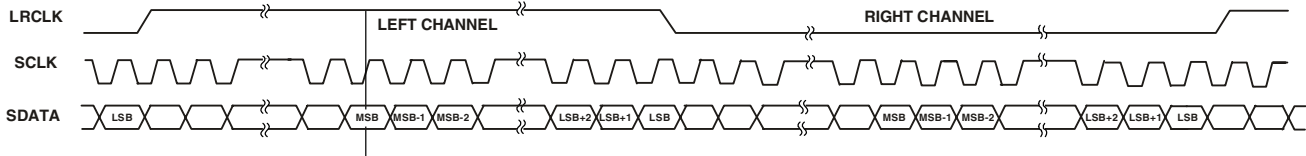

Figure 29. Right-Justified Mode

Figure 30 shows the default I<sup>2</sup>S-justified mode. LRCLK is LO for the left channel and HI for the right channel. Data is valid on the rising edge of SCLK. The MSB is left-justified to an LRCLK transition but with a single SCLK period delay.

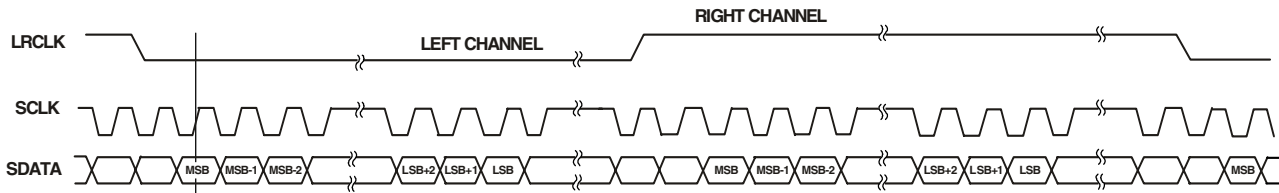

Figure 30. I<sup>2</sup>S-Justified Mode

Figure 31 shows the left-justified mode. LRCLK is HI for the left channel and LO for the right channel. Data is valid on the rising edge of SCLK. The MSB is left-justified to an LRCLK transition with no MSB delay.

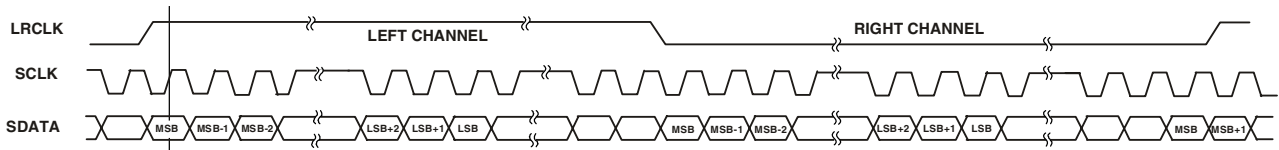

Figure 31. Left-Justified Mode

# ADSP-21362/ADSP-21363/ADSP-21364/ADSP-21365/ADSP-21366

## S/PDIF Transmitter Input Data Timing

The timing requirements for the input port are given in [Table 36](#). Input signals (SCLK, FS, and SDATA) are routed to the DAI\_P20-1 pins using the SRU. Therefore, the timing specifications provided below are valid at the DAI\_P20-1 pins.

**Table 36. S/PDIF Transmitter Input Data Timing**

Parameter		K and B Grade		Y Grade		Unit
		Min		Min	Max	
<i>Timing Requirements</i>						
$t_{SIFS}^1$	FS Setup Before SCLK Rising Edge	3		3		ns
$t_{SIHFS}^1$	FS Hold After SCLK Rising Edge	3		3		ns
$t_{SISD}^1$	SDATA Setup Before SCLK Rising Edge	3		3		ns
$t_{SIHD}^1$	SDATA Hold After SCLK Rising Edge	3		3		ns
$t_{SISCLKW}$	Clock Width	36		36		ns
$t_{SISCLK}$	Clock Period	80		80		ns
$t_{SITXCLKW}$	Transmit Clock Width	9		9.5		ns
$t_{SITXCLK}$	Transmit Clock Period	20		20		ns

<sup>1</sup> DATA, SCLK, FS can come from any of the DAI pins. SCLK and FS can also come via PCG or SPORTs. PCG's input can be either CLKIN or any of the DAI pins.

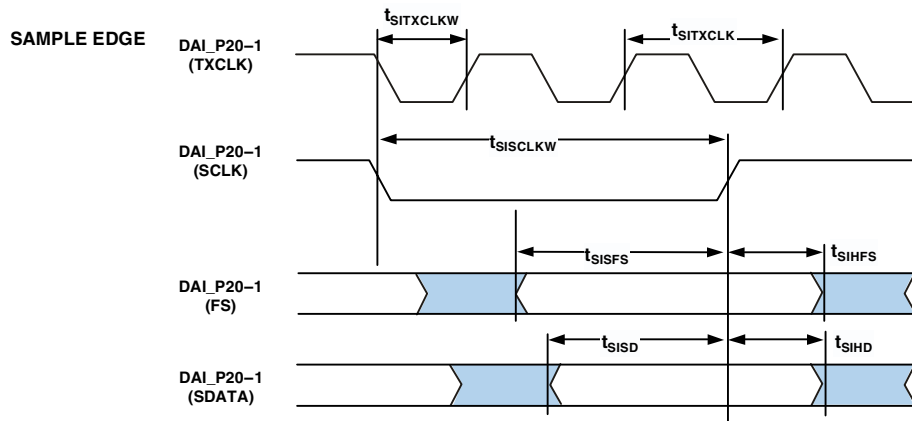

Figure 32. S/PDIF Transmitter Input Timing

## Oversampling Clock (TXCLK) Switching Characteristics

S/PDIF Transmitter has an oversampling clock. This TXCLK input is divided down to generate the biphase clock.

**Table 37. Oversampling Clock (TXCLK) Switching Characteristics**

Parameter	Min	Max	Unit
TXCLK Frequency for TXCLK = 384 × FS		73.8	MHz
TXCLK Frequency for TXCLK = 256 × FS		49.2	MHz
Frame Rate		192.0	kHz

# ADSP-21362/ADSP-21363/ADSP-21364/ADSP-21365/ADSP-21366

## S/PDIF Receiver

The following section describes timing as it relates to the S/PDIF receiver. This feature is not available on the ADSP-21363 models.

### Internal Digital PLL Mode

In the internal digital phase-locked loop mode the internal PLL (digital PLL) generates the  $512 \times FS$  clock.

**Table 38. S/PDIF Receiver Output Timing (Internal Digital PLL Mode)**

Parameter		Min	Max	Unit
<i>Switching Characteristics</i>				
$t_{DFSI}$	LRCLK Delay After SCLK		5	ns
$t_{HOFSI}$	LRCLK Hold After SCLK	-2		ns
$t_{DDTI}$	Transmit Data Delay After SCLK		5	ns
$t_{HDTI}$	Transmit Data Hold After SCLK	-2		ns
$t_{SCLKIW}^1$	Transmit SCLK Width	38		ns

<sup>1</sup>SCLK frequency is  $64 \times FS$  where FS = the frequency of LRCLK.

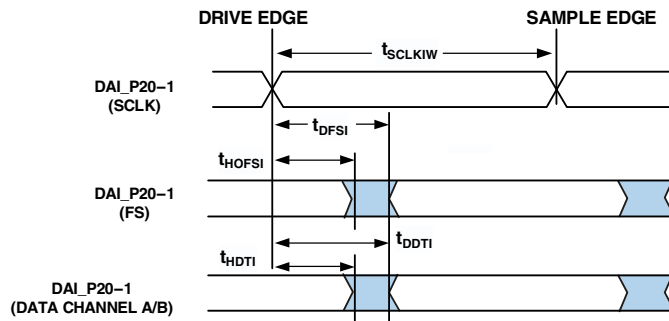

Figure 33. SPDIF Receiver Internal Digital PLL Mode Timing

# ADSP-21362/ADSP-21363/ADSP-21364/ADSP-21365/ADSP-21366

## SPI Interface—Master

The ADSP-2136x contains two SPI ports. The primary has dedicated pins and the secondary is available through the DAI. The timing provided in [Table 39](#) and [Table 40](#) applies to both.

**Table 39. SPI Interface Protocol—Master Switching and Timing Specifications**

Parameter	K and B Grade		Y Grade		Unit
	Min	Max	Min	Max	
<i>Timing Requirements</i>					
$t_{SSPIDM}$	Data Input Valid to SPICLK Edge (Data Input Setup Time)		5.2	6.2	ns
$t_{SSPIDM}$	Data Input Valid to SPICLK Edge (Data Input Setup Time) (SPI2)		8.2	9.5	ns
$t_{HSPIDM}$	SPICLK Last Sampling Edge to Data Input Not Valid		2	2	ns
<i>Switching Characteristics</i>					
$t_{SPICLK M}$	Serial Clock Cycle		$8 \times t_{PCLK} - 2$	$8 \times t_{PCLK} - 2$	ns
$t_{SPICH M}$	Serial Clock High Period		$4 \times t_{PCLK} - 2$	$4 \times t_{PCLK} - 2$	ns
$t_{SPICL M}$	Serial Clock Low Period		$4 \times t_{PCLK} - 2$	$4 \times t_{PCLK} - 2$	ns
$t_{DDSPID M}$	SPICLK Edge to Data Out Valid (Data Out Delay Time)			3.0	ns
$t_{DDSPID M}$	SPICLK Edge to Data Out Valid (Data Out Delay Time) (SPI2)			8.0	ns
$t_{HDSPID M}$	SPICLK Edge to Data Out Not Valid (Data Out Hold Time)		$4 \times t_{PCLK} - 2$	$4 \times t_{PCLK} - 2$	ns
$t_{SDSCIM}$	FLAG3-0IN (SPI Device Select) Low to First SPICLK Edge		$4 \times t_{PCLK} - 2.5$	$4 \times t_{PCLK} - 3.0$	ns
$t_{SDSCIM}$	FLAG3-0IN (SPI Device Select) Low to First SPICLK Edge (SPI2)		$4 \times t_{PCLK} - 2.5$	$4 \times t_{PCLK} - 3.0$	ns
$t_{HDSM}$	Last SPICLK Edge to FLAG3-0IN High		$4 \times t_{PCLK} - 2$	$4 \times t_{PCLK} - 2$	ns
$t_{SPITDM}$	Sequential Transfer Delay		$4 \times t_{PCLK} - 1$	$4 \times t_{PCLK} - 1$	ns

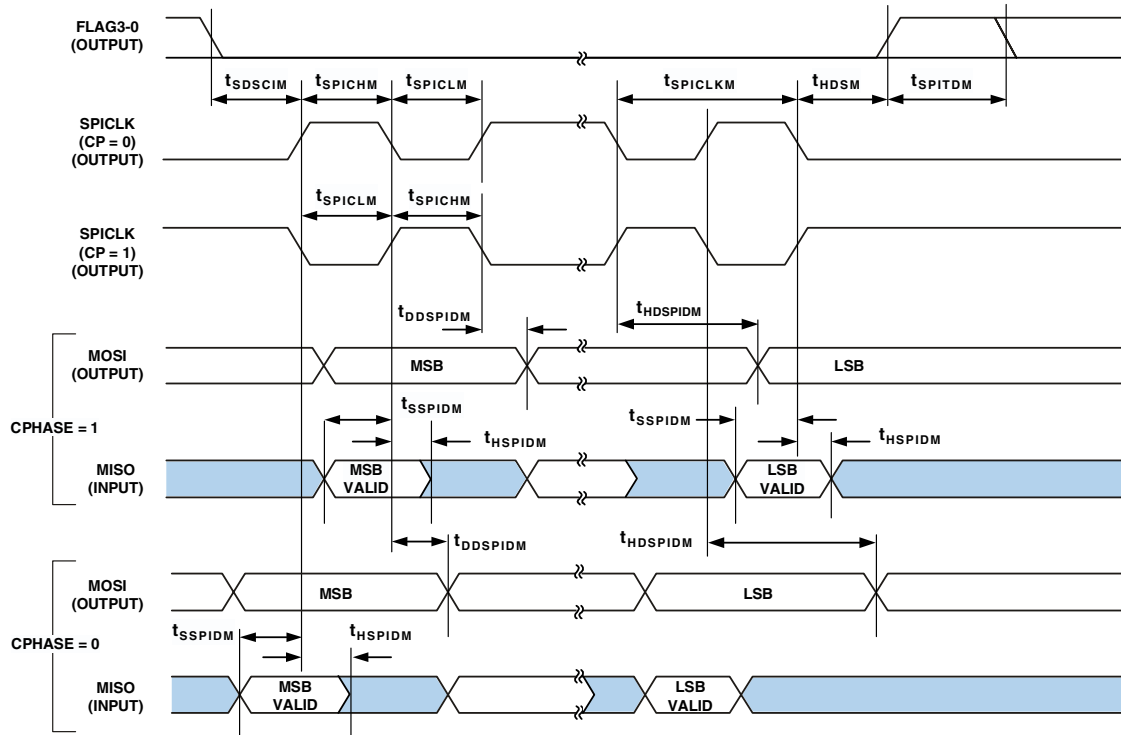

Figure 34. SPI Master Timing

# ADSP-21362/ADSP-21363/ADSP-21364/ADSP-21365/ADSP-21366

## SPI Interface—Slave

Table 40. SPI Interface Protocol—Slave Switching and Timing Specifications

Parameter		K and B Grade		Y Grade	Unit
		Min	Max	Max	
<i>Timing Requirements</i>					
$t_{SPICLK}$	Serial Clock Cycle	$4 \times t_{PCLK} - 2$			ns
$t_{SPICHS}$	Serial Clock High Period	$2 \times t_{PCLK} - 2$			ns
$t_{SPICLS}$	Serial Clock Low Period	$2 \times t_{PCLK} - 2$			ns
$t_{SDSCO}$	$\overline{SPIDS}$ Assertion to First SPICLK Edge				
	CPHASE = 0	$2 \times t_{PCLK}$			ns
	CPHASE = 1	$2 \times t_{PCLK}$			ns
$t_{HDS}$	Last SPICLK Edge to $\overline{SPIDS}$ Not Asserted, CPHASE = 0	$2 \times t_{PCLK}$			ns
$t_{SSPIDS}$	Data Input Valid to SPICLK Edge (Data Input Setup Time)	2			ns
$t_{HSPIDS}$	SPICLK Last Sampling Edge to Data Input Not Valid	2			ns
$t_{SDPPW}$	$\overline{SPIDS}$ Deassertion Pulse Width (CPHASE = 0)	$2 \times t_{PCLK}$			ns
<i>Switching Characteristics</i>					
$t_{DSOE}$	$\overline{SPIDS}$ Assertion to Data Out Active	0	5	5	ns
$t_{DSOE}^1$	$\overline{SPIDS}$ Assertion to Data Out Active (SPI2)	0	8	9	ns
$t_{DSDHI}$	$\overline{SPIDS}$ Deassertion to Data High Impedance	0	5	5.5	ns
$t_{DSDHI}^1$	$\overline{SPIDS}$ Deassertion to Data High Impedance (SPI2)	0	8.6	10	ns
$t_{DDSPIDS}$	SPICLK Edge to Data Out Valid (Data Out Delay Time)	9.5		11.0	ns
$t_{HDSPIDS}$	SPICLK Edge to Data Out Not Valid (Data Out Hold Time)	$2 \times t_{PCLK}$			ns
$t_{DSOV}$	$\overline{SPIDS}$ Assertion to Data Out Valid (CPHASE = 0)	$5 \times t_{PCLK}$		$5 \times t_{PCLK}$	ns

<sup>1</sup>The timing for these parameters applies when the SPI is routed through the signal routing unit. For more information, see the *ADSP-2136x SHARC Processor Hardware Reference*, “Serial Peripheral Interface Port” chapter.



# ADSP-21362/ADSP-21363/ADSP-21364/ADSP-21365/ADSP-21366

## JTAG Test Access Port and Emulation

Table 41. JTAG Test Access Port and Emulation

Parameter	Min	Max	Unit
<i>Timing Requirements</i>			
$t_{TCK}$ TCK Period	$t_{CK}$		ns
$t_{STAP}$ TDI, TMS Setup Before TCK High	5		ns
$t_{HTAP}$ TDI, TMS Hold After TCK High	6		ns
$t_{SSYS}^1$ System Inputs Setup Before TCK High	7		ns
$t_{HSYS}^1$ System Inputs Hold After TCK High	18		ns
$t_{TRSTW}$ $\overline{TRST}$ Pulse Width	$4t_{CK}$		ns
<i>Switching Characteristics</i>			
$t_{DTDO}$ TDO Delay from TCK Low		7	ns
$t_{DSYS}^2$ System Outputs Delay After TCK Low		$t_{CK} \div 2 + 7$	ns

<sup>1</sup>System Inputs = AD15-0,  $\overline{SPIDS}$ , CLK\_CFG1-0,  $\overline{RESET}$ , BOOT\_CFG1-0, MISO, MOSI, SPICLK, DAI\_Px, FLAG3-0.

<sup>2</sup>System Outputs = MISO, MOSI, SPICLK, DAI\_Px, AD15-0,  $\overline{RD}$ ,  $\overline{WR}$ , FLAG3-0, CLKOUT,  $\overline{EMU}$ , ALE.

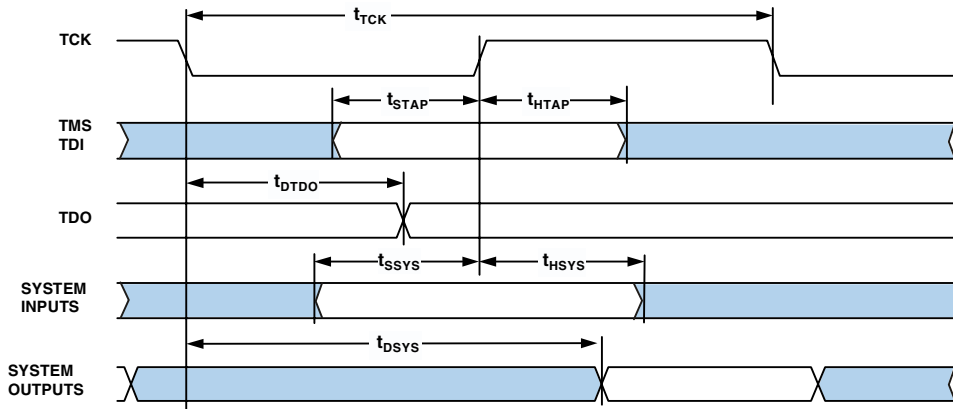

Figure 36. IEEE 1149.1 JTAG Test Access Port

## OUTPUT DRIVE CURRENTS

Figure 37 shows typical I-V characteristics for the output drivers of the ADSP-2136x. The curves represent the current drive capability of the output drivers as a function of output voltage.

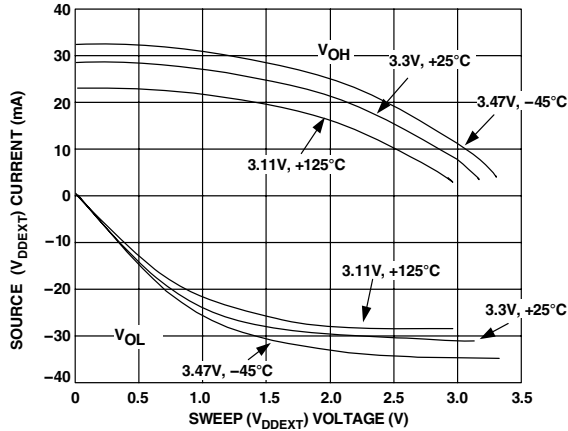

Figure 37. ADSP-2136x Typical Drive

## TEST CONDITIONS

The ac signal specifications (timing parameters) appear in Table 15 on Page 21 through Table 41 on Page 44. These include output disable time, output enable time, and capacitive loading. The timing specifications for the SHARC apply for the voltage reference levels in Figure 38.

Timing is measured on signals when they cross the 1.5 V level as described in Figure 39. All delays (in nanoseconds) are measured between the point that the first signal reaches 1.5 V and the point that the second signal reaches 1.5 V.

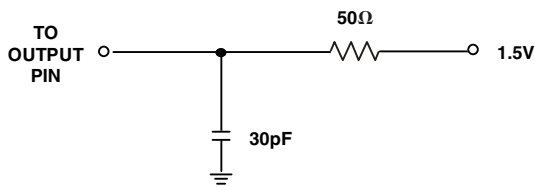

Figure 38. Equivalent Device Loading for AC Measurements (Includes All Fixtures)



Figure 39. Voltage Reference Levels for AC Measurements

## CAPACITIVE LOADING

Output delays and holds are based on standard capacitive loads: 30 pF on all pins (see Figure 38). Figure 42 shows graphically how output delays and holds vary with load capacitance. The graphs of Figure 40, Figure 41, and Figure 42 may not be linear outside the ranges shown for Typical Output Delay vs. Load Capacitance and Typical Output Rise Time (20% to 80%, V = Min) vs. Load Capacitance.

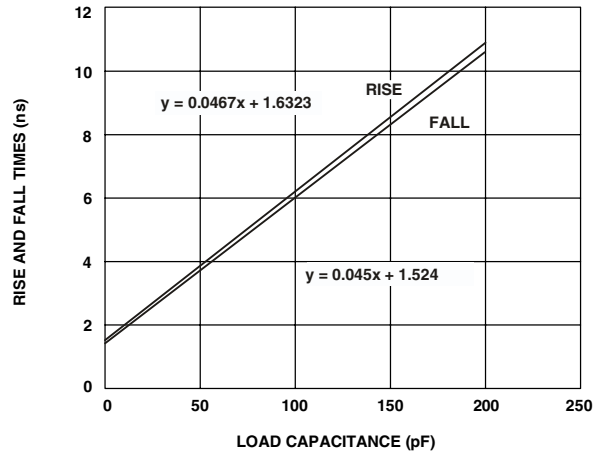

Figure 40. Typical Output Rise/Fall Time (20% to 80%,  $V_{DDEXT} = Max$ )

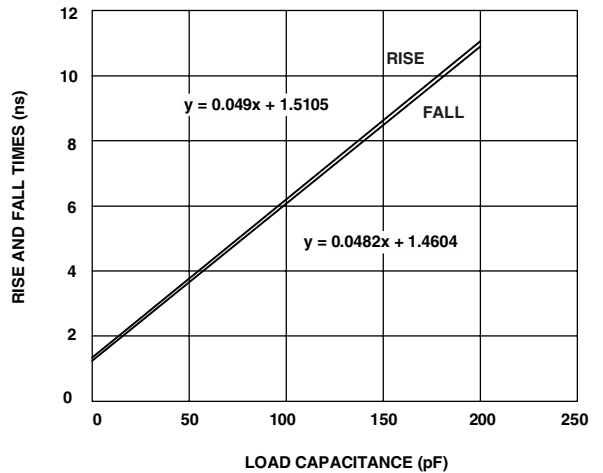

Figure 41. Typical Output Rise/Fall Time (20% to 80%,  $V_{DDEXT} = Min$ )

# ADSP-21362/ADSP-21363/ADSP-21364/ADSP-21365/ADSP-21366

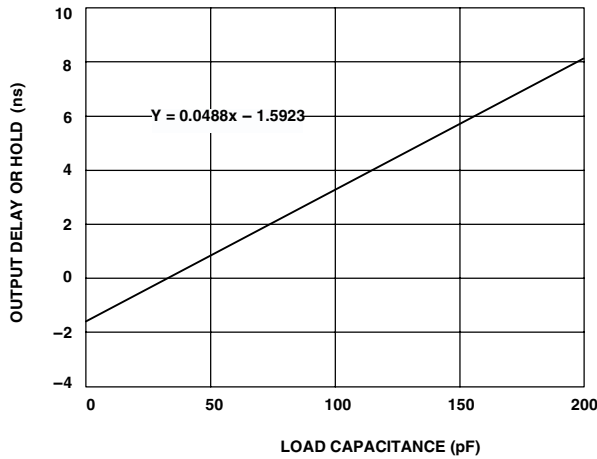

Figure 42. Typical Output Delay or Hold vs. Load Capacitance (at Ambient Temperature)

## THERMAL CHARACTERISTICS

The ADSP-2136x processor is rated for performance over the temperature range specified in Operating Conditions on Page 16.

Table 42 through Table 44 airflow measurements comply with JEDEC standards JESD51-2 and JESD51-6 and the junction-to-board measurement complies with JESD51-8. Test board and thermal via design comply with JEDEC standards JESD51-9 (BGA) and JESD51-5 (LQFP\_EP). The junction-to-case measurement complies with MIL-STD-883. All measurements use a 2S2P JEDEC test board.

Industrial applications using the BGA package require thermal vias, to an embedded ground plane, in the PCB. Refer to JEDEC standard JESD51-9 for printed circuit board thermal ball land and thermal via design information.

Industrial applications using the LQFP\_EP package require thermal trace squares and thermal vias, to an embedded ground plane, in the PCB. Refer to JEDEC standard JESD51-5 for more information.

To determine the junction temperature of the device while on the application PCB, use:

$$T_j = T_T + (\Psi_{JT} \times P_D)$$

where:

$T_j$  = junction temperature (°C)

$T_T$  = case temperature (°C) measured at the top center of the package

$\Psi_{JT}$  = junction-to-top (of package) characterization parameter is the typical value from Table 42 through Table 44.

$P_D$  = power dissipation *Estimating Power for the ADSP-21362 SHARC Processors (EE-277)* for more information.

Values of  $\theta_{JA}$  are provided for package comparison and PCB design considerations.

Values of  $\theta_{JC}$  are provided for package comparison and PCB design considerations when an exposed pad is required. Note that the thermal characteristics values provided in Table 42 through Table 44 are modeled values.

Table 42. Thermal Characteristics for BGA (No Thermal vias in PCB)

Parameter	Condition	Typical	Unit
$\theta_{JA}$	Airflow = 0 m/s	25.40	°C/W
$\theta_{JMA}$	Airflow = 1 m/s	21.90	°C/W
$\theta_{JMA}$	Airflow = 2 m/s	20.90	°C/W
$\theta_{JC}$		5.07	°C/W
$\Psi_{JT}$	Airflow = 0 m/s	0.140	°C/W
$\Psi_{JMT}$	Airflow = 1 m/s	0.330	°C/W
$\Psi_{JMT}$	Airflow = 2 m/s	0.410	°C/W

Table 43. Thermal Characteristics for BGA (Thermal vias in PCB)

Parameter	Condition	Typical	Unit
$\theta_{JA}$	Airflow = 0 m/s	23.40	°C/W
$\theta_{JMA}$	Airflow = 1 m/s	20.00	°C/W
$\theta_{JMA}$	Airflow = 2 m/s	19.20	°C/W
$\theta_{JC}$		5.00	°C/W
$\Psi_{JT}$	Airflow = 0 m/s	0.130	°C/W
$\Psi_{JMT}$	Airflow = 1 m/s	0.300	°C/W
$\Psi_{JMT}$	Airflow = 2 m/s	0.360	°C/W

Table 44. Thermal Characteristics for LQFP\_EP (with Exposed Pad Soldered to PCB)

Parameter	Condition	Typical	Unit
$\theta_{JA}$	Airflow = 0 m/s	16.80	°C/W
$\theta_{JMA}$	Airflow = 1 m/s	14.20	°C/W
$\theta_{JMA}$	Airflow = 2 m/s	13.50	°C/W
$\theta_{JC}$		7.25	°C/W
$\Psi_{JT}$	Airflow = 0 m/s	0.51	°C/W
$\Psi_{JMT}$	Airflow = 1 m/s	0.72	°C/W
$\Psi_{JMT}$	Airflow = 2 m/s	0.80	°C/W

# ADSP-21362/ADSP-21363/ADSP-21364/ADSP-21365/ADSP-21366

## 144-LEAD LQFP PIN CONFIGURATIONS

The following table shows the ADSP-2136x's pin names and their default function after reset (in parentheses).

**Table 45. LQFP Pin Assignments**

Pin Name	Pin No.	Pin Name	Pin No.	Pin Name	Pin No.	Pin Name	Pin No.
V <sub>DDINT</sub>	1	V <sub>DDINT</sub>	37	V <sub>DDEXT</sub>	73	GND	109
CLK_CFG0	2	GND	38	GND	74	V <sub>DDINT</sub>	110
CLK_CFG1	3	$\overline{\text{RD}}$	39	V <sub>DDINT</sub>	75	GND	111
BOOT_CFG0	4	ALE	40	GND	76	V <sub>DDINT</sub>	112
BOOT_CFG1	5	AD15	41	DAI_P10 (SD2B)	77	GND	113
GND	6	AD14	42	DAI_P11 (SD3A)	78	V <sub>DDINT</sub>	114
V <sub>DDEXT</sub>	7	AD13	43	DAI_P12 (SD3B)	79	GND	115
GND	8	GND	44	DAI_P13 (SCLK3)	80	V <sub>DDEXT</sub>	116
V <sub>DDINT</sub>	9	V <sub>DDEXT</sub>	45	DAI_P14 (SFS3)	81	GND	117
GND	10	AD12	46	DAI_P15 (SD4A)	82	V <sub>DDINT</sub>	118
V <sub>DDINT</sub>	11	V <sub>DDINT</sub>	47	V <sub>DDINT</sub>	83	GND	119
GND	12	GND	48	GND	84	V <sub>DDINT</sub>	120
V <sub>DDINT</sub>	13	AD11	49	GND	85	$\overline{\text{RESET}}$	121
GND	14	AD10	50	DAI_P16 (SD4B)	86	$\overline{\text{SPID}}\overline{\text{S}}$	122
FLAG0	15	AD9	51	DAI_P17 (SD5A)	87	GND	123
FLAG1	16	AD8	52	DAI_P18 (SD5B)	88	V <sub>DDINT</sub>	124
AD7	17	DAI_P1 (SD0A)	53	DAI_P19 (SCLK5)	89	SPICLK	125
GND	18	V <sub>DDINT</sub>	54	V <sub>DDINT</sub>	90	MISO	126
V <sub>DDINT</sub>	19	GND	55	GND	91	MOSI	127
GND	20	DAI_P2 (SD0B)	56	GND	92	GND	128
V <sub>DDEXT</sub>	21	DAI_P3 (SCLK0)	57	V <sub>DDEXT</sub>	93	V <sub>DDINT</sub>	129
GND	22	GND	58	DAI_P20 (SFS5)	94	V <sub>DDEXT</sub>	130
V <sub>DDINT</sub>	23	V <sub>DDEXT</sub>	59	GND	95	A <sub>VDD</sub>	131
AD6	24	V <sub>DDINT</sub>	60	V <sub>DDINT</sub>	96	A <sub>VSS</sub>	132
AD5	25	GND	61	FLAG2	97	GND	133
AD4	26	DAI_P4 (SFS0)	62	FLAG3	98	$\overline{\text{RESETOUT}}/\text{CLKOUT}$	134
V <sub>DDINT</sub>	27	DAI_P5 (SD1A)	63	V <sub>DDINT</sub>	99	$\overline{\text{EMU}}$	135
GND	28	DAI_P6 (SD1B)	64	GND	100	TDO	136
AD3	29	DAI_P7 (SCLK1)	65	V <sub>DDINT</sub>	101	TDI	137
AD2	30	V <sub>DDINT</sub>	66	GND	102	$\overline{\text{TRST}}$	138
V <sub>DDEXT</sub>	31	GND	67	V <sub>DDINT</sub>	103	TCK	139
GND	32	V <sub>DDINT</sub>	68	GND	104	TMS	140
AD1	33	GND	69	V <sub>DDINT</sub>	105	GND	141
AD0	34	DAI_P8 (SFS1)	70	GND	106	CLKIN	142
$\overline{\text{WR}}$	35	DAI_P9 (SD2A)	71	V <sub>DDINT</sub>	107	XTAL	143
V <sub>DDINT</sub>	36	V <sub>DDINT</sub>	72	V <sub>DDINT</sub>	108	V <sub>DDEXT</sub>	144

# ADSP-21362/ADSP-21363/ADSP-21364/ADSP-21365/ADSP-21366

## 136-BALL BGA PIN CONFIGURATIONS

The following table shows the ADSP-2136x's pin names and their default function after reset (in parentheses).

Table 46. BGA Pin Assignments

Ball Name	Ball No.	Ball Name	Ball No.	Ball Name	Ball No.	Ball Name	Ball No.
CLK_CFG0	A01	CLK_CFG1	B01	BOOT_CFG1	C01	V <sub>DDINT</sub>	D01
XTAL	A02	GND	B02	BOOT_CFG0	C02	GND	D02
TMS	A03	V <sub>DDEXT</sub>	B03	GND	C03	GND	D04
TCK	A04	CLKIN	B04	GND	C12	GND	D05
TDI	A05	$\overline{\text{TRST}}$	B05	GND	C13	GND	D06
$\overline{\text{RESETOUT}}/\text{CLKOUT}$	A06	A <sub>VSS</sub>	B06	V <sub>DDINT</sub>	C14	GND	D09
TDO	A07	A <sub>VDD</sub>	B07			GND	D10
$\overline{\text{EMU}}$	A08	V <sub>DDEXT</sub>	B08			GND	D11
MOSI	A09	SPICLK	B09			GND	D13
MISO	A10	$\overline{\text{RESET}}$	B10			V <sub>DDINT</sub>	D14
$\overline{\text{SPIDS}}$	A11	V <sub>DDINT</sub>	B11				
V <sub>DDINT</sub>	A12	GND	B12				
GND	A13	GND	B13				
GND	A14	GND	B14				
V <sub>DDINT</sub>	E01	FLAG1	F01	AD7	G01	AD6	H01
GND	E02	FLAG0	F02	V <sub>DDINT</sub>	G02	V <sub>DDEXT</sub>	H02
GND	E04	GND	F04	V <sub>DDEXT</sub>	G13	DAI_P18 (SD5B)	H13
GND	E05	GND	F05	DAI_P19 (SCLK5)	G14	DAI_P17 (SD5A)	H14
GND	E06	GND	F06				
GND	E09	GND	F09				
GND	E10	GND	F10				
GND	E11	GND	F11				
GND	E13	FLAG2	F13				
FLAG3	E14	DAI_P20 (SFS5)	F14				

# ADSP-21362/ADSP-21363/ADSP-21364/ADSP-21365/ADSP-21366

**Table 46. BGA Pin Assignments (Continued)**

Ball Name	Ball No.	Ball Name	Ball No.	Ball Name	Ball No.	Ball Name	Ball No.
AD5	J01	AD3	K01	AD2	L01	AD0	M01
AD4	J02	V <sub>DDINT</sub>	K02	AD1	L02	$\overline{WR}$	M02
GND	J04	GND	K04	GND	L04	GND	M03
GND	J05	GND	K05	GND	L05	GND	M12
GND	J06	GND	K06	GND	L06	DAI_P12 (SD3B)	M13
GND	J09	GND	K09	GND	L09	DAI_P13 (SCLK3)	M14
GND	J10	GND	K10	GND	L10		
GND	J11	GND	K11	GND	L11		
V <sub>DDINT</sub>	J13	GND	K13	GND	L13		
DAI_P16 (SD4B)	J14	DAI_P15 (SD4A)	K14	DAI_P14 (SFS3)	L14		
AD15	N01	AD14	P01				
ALE	N02	AD13	P02				
$\overline{RD}$	N03	AD12	P03				
V <sub>DDINT</sub>	N04	AD11	P04				
V <sub>DDEXT</sub>	N05	AD10	P05				
AD8	N06	AD9	P06				
V <sub>DDINT</sub>	N07	DAI_P1 (SD0A)	P07				
DAI_P2 (SD0B)	N08	DAI_P3 (SCLK0)	P08				
V <sub>DDEXT</sub>	N09	DAI_P5 (SD1A)	P09				
DAI_P4 (SFS0)	N10	DAI_P6 (SD1B)	P10				
V <sub>DDINT</sub>	N11	DAI_P7 (SCLK1)	P11				
V <sub>DDINT</sub>	N12	DAI_P8 (SFS1)	P12				
GND	N13	DAI_P9 (SD2A)	P13				
DAI_P10 (SD2B)	N14	DAI_P11 (SD3A)	P14				

# ADSP-21362/ADSP-21363/ADSP-21364/ADSP-21365/ADSP-21366

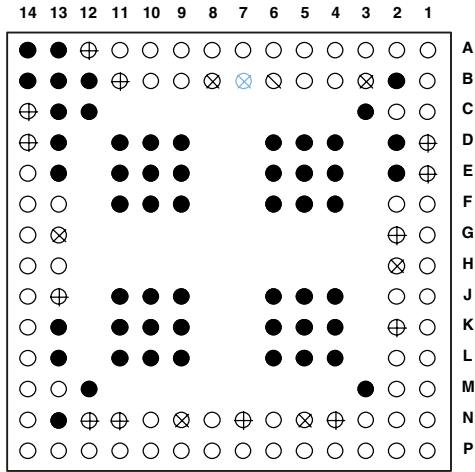

## KEY

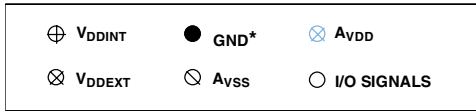

\*USE THE CENTER BLOCK OF GROUND PINS TO PROVIDE THERMAL PATHWAYS TO YOUR PRINTED CIRCUIT BOARD'S GROUND PLANE.

Figure 43. BGA Pin Assignments (Bottom View, Summary)

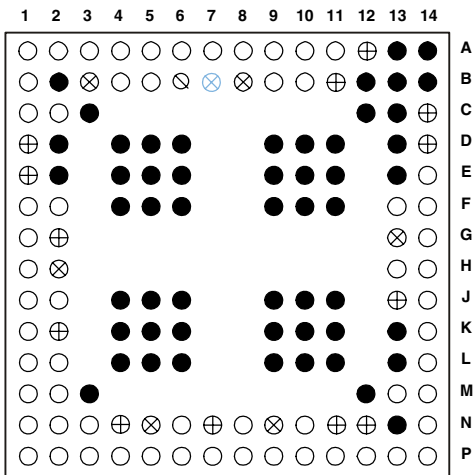

## KEY

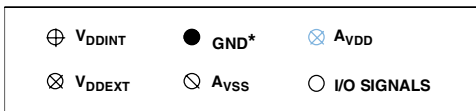

\*USE THE CENTER BLOCK OF GROUND PINS TO PROVIDE THERMAL PATHWAYS TO YOUR PRINTED CIRCUIT BOARD'S GROUND PLANE.

Figure 44. BGA Pin Assignments (Top View, Summary)

# ADSP-21362/ADSP-21363/ADSP-21364/ADSP-21365/ADSP-21366

## OUTLINE DIMENSIONS

The ADSP-2136x is available in 136-ball BGA and 144-lead exposed pad (LQFP\_EP) packages.

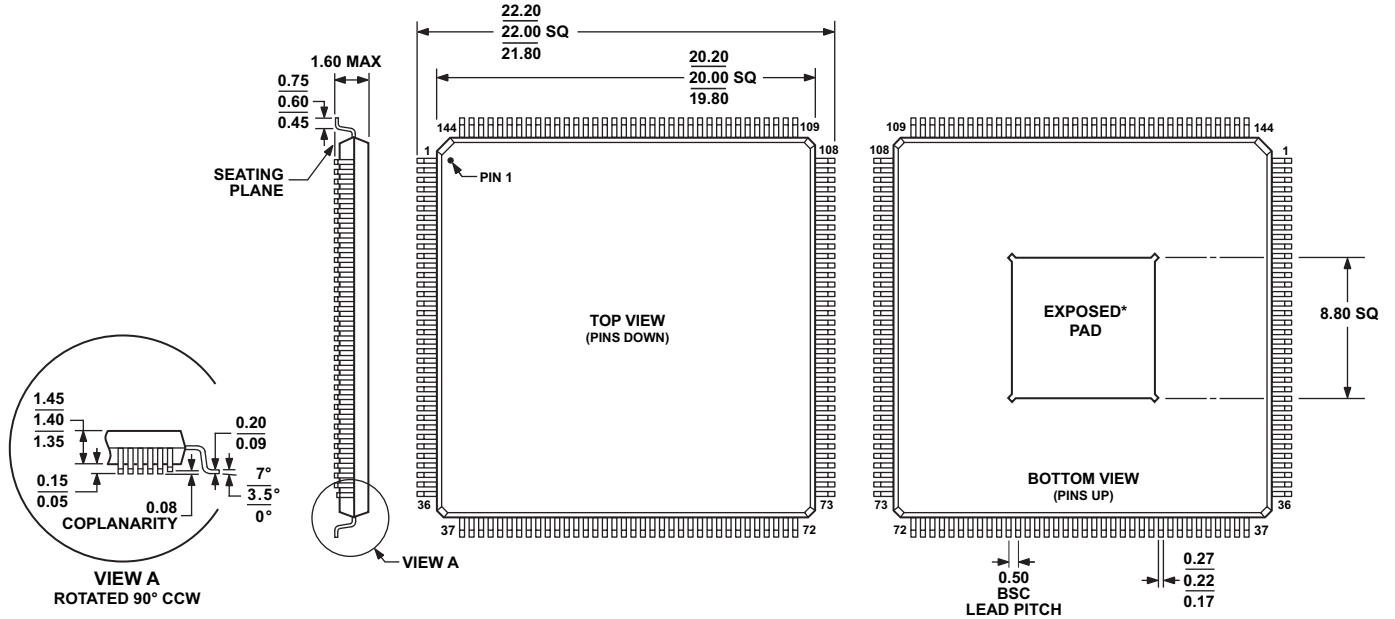

COMPLIANT TO JEDEC STANDARDS MS-026-BFB-HD

\*EXPOSED PAD IS COINCIDENT WITH BOTTOM SURFACE AND DOES NOT PROTRUDE BEYOND IT. EXPOSED PAD IS CENTERED.

Figure 45. 144-Lead Low Profile Quad Flat Package, Exposed Pad [LQFP\_EP] (SW-144-1)  
Dimensions shown in millimeters

# ADSP-21362/ADSP-21363/ADSP-21364/ADSP-21365/ADSP-21366

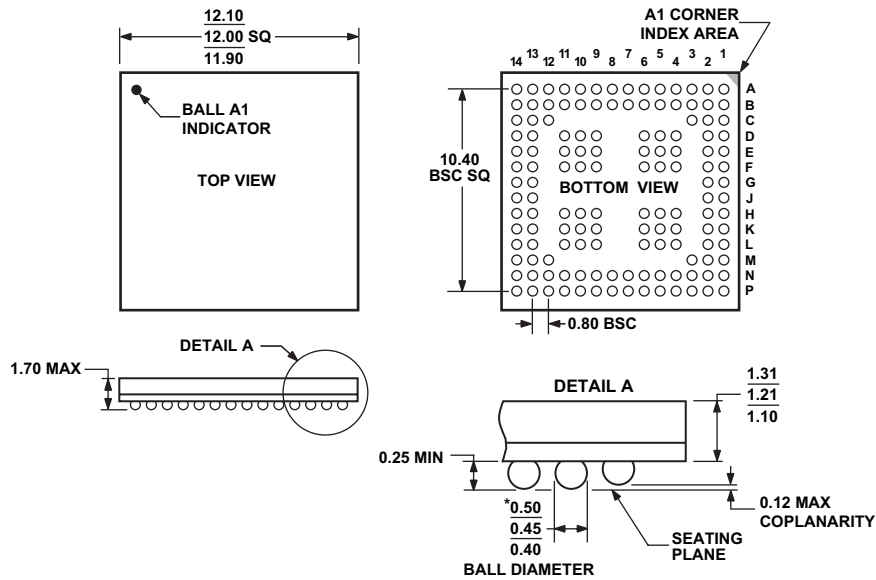

\*COMPLIANT WITH JEDEC STANDARDS MO-205-AE WITH EXCEPTION TO BALL DIAMETER.

Figure 46. 136-Ball Chip Scale Package Ball Grid Array [CSP\_BGA] (BC-136)

Dimensions shown in millimeters

## SURFACE MOUNT DESIGN

Table 47 is provided as an aide to PCB design. For industry-standard design recommendations, refer to IPC-7351, *Generic Requirements for Surface Mount Design and Land Pattern Standard*.

Table 47. BGA Data for Use with Surface Mount Design

Package	Ball Attach Type	Solder Mask Opening	Ball Pad Size
136-Ball CSP_BGA (BC-136)	Solder Mask Defined	0.40 mm diameter	0.53 mm diameter

# ADSP-21362/ADSP-21363/ADSP-21364/ADSP-21365/ADSP-21366

## ORDERING GUIDE

Model	Temperature Range <sup>1</sup>	Instruction Rate	On-Chip SRAM	ROM	Operating Voltage Internal/ External	Package Description	Package Option
ADSP-21362KBC-1AA <sup>2</sup>	0°C to +70°C	333 MHz	3M Bit	4M Bit	1.2 V/3.3 V	136-Ball CSP_BGA	BC-136
ADSP-21362KBCZ-1AA <sup>2, 3</sup>	0°C to +70°C	333 MHz	3M Bit	4M Bit	1.2 V/3.3 V	136-Ball CSP_BGA	BC-136
ADSP-21362BBC-1AA <sup>2</sup>	-40°C to +85°C	333 MHz	3M Bit	4M Bit	1.2 V/3.3 V	136-Ball CSP_BGA	BC-136
ADSP-21362BBCZ-1AA <sup>2, 3</sup>	-40°C to +85°C	333 MHz	3M Bit	4M Bit	1.2 V/3.3 V	136-Ball CSP_BGA	BC-136
ADSP-21362WBBCZ-1A <sup>2, 3</sup>	-40°C to +85°C	333 MHz	3M Bit	4M Bit	1.2 V/3.3 V	136-Ball CSP_BGA	BC-136
ADSP-21362KSWZ-1AA <sup>2</sup>	0°C to +70°C	333 MHz	3M Bit	4M Bit	1.2 V/3.3 V	144-Lead LQFP_EP	SW-144-1
ADSP-21362BSWZ-1AA <sup>2, 3</sup>	-40°C to +85°C	333 MHz	3M Bit	4M Bit	1.2 V/3.3 V	144-Lead LQFP_EP	SW-144-1
ADSP-21362WBSWZ-1A <sup>2, 3, 4</sup>	-40°C to +85°C	333 MHz	3M Bit	4M Bit	1.2 V/3.3 V	144-Lead LQFP_EP	SW-144-1
ADSP-21362YSWZ-2AA <sup>2, 3</sup>	-40°C to +105°C	200 MHz	3M Bit	4M Bit	1.0 V/3.3 V	144-Lead LQFP_EP	SW-144-1
ADSP-21362WYSWZ-2A <sup>2, 3, 4</sup>	-40°C to +105°C	200 MHz	3M Bit	4M Bit	1.0 V/3.3 V	144-Lead LQFP_EP	SW-144-1
ADSP-21363KBC-1AA	0°C to +70°C	333 MHz	3M Bit	4M Bit	1.2 V/3.3 V	136-Ball CSP_BGA	BC-136
ADSP-21363KBCZ-1AA <sup>3</sup>	0°C to +70°C	333 MHz	3M Bit	4M Bit	1.2 V/3.3 V	136-Ball CSP_BGA	BC-136
ADSP-21363KSWZ-1AA <sup>3</sup>	0°C to +70°C	333 MHz	3M Bit	4M Bit	1.2 V/3.3 V	144-Lead LQFP_EP	SW-144-1
ADSP-21363BBC-1AA	-40°C to +85°C	333 MHz	3M Bit	4M Bit	1.2 V/3.3 V	136-Ball CSP_BGA	BC-136
ADSP-21363BBCZ-1AA <sup>3</sup>	-40°C to +85°C	333 MHz	3M Bit	4M Bit	1.2 V/3.3 V	136-Ball CSP_BGA	BC-136
ADSP-21363WBBCZ-1A <sup>3</sup>	-40°C to +85°C	333 MHz	3M Bit	4M Bit	1.2 V/3.3 V	136-Ball CSP_BGA	BC-136
ADSP-21363BSWZ-1AA <sup>3</sup>	-40°C to +85°C	333 MHz	3M Bit	4M Bit	1.2 V/3.3 V	144-Lead LQFP_EP	SW-144-1
ADSP-21363WBSWZ-1A <sup>3, 4</sup>	-40°C to +85°C	333 MHz	3M Bit	4M Bit	1.2 V/3.3 V	144-Lead LQFP_EP	SW-144-1
ADSP-21363YSWZ-2AA <sup>3, 4</sup>	-40°C to +105°C	200 MHz	3M Bit	4M Bit	1.0 V/3.3 V	144-Lead LQFP_EP	SW-144-1
ADSP-21363WYSWZ-2A <sup>3, 4</sup>	-40°C to +105°C	200 MHz	3M Bit	4M Bit	1.0 V/3.3 V	144-Lead LQFP_EP	SW-144-1
ADSP-21364KBC-1AA	0°C to +70°C	333 MHz	3M Bit	4M Bit	1.2 V/3.3 V	136-Ball CSP_BGA	BC-136
ADSP-21364KBCZ-1AA <sup>3</sup>	0°C to +70°C	333 MHz	3M Bit	4M Bit	1.2 V/3.3 V	136-Ball CSP_BGA	BC-136
ADSP-21364KSWZ-1AA <sup>3</sup>	0°C to +70°C	333 MHz	3M Bit	4M Bit	1.2 V/3.3 V	144-Lead LQFP_EP	SW-144-1
ADSP-21364BBC-1AA	-40°C to +85°C	333 MHz	3M Bit	4M Bit	1.2 V/3.3 V	136-Ball CSP_BGA	BC-136
ADSP-21364BBCZ-1AA <sup>3</sup>	-40°C to +85°C	333 MHz	3M Bit	4M Bit	1.2 V/3.3 V	136-Ball CSP_BGA	BC-136
ADSP-21364WBBCZ-1A <sup>3</sup>	-40°C to +85°C	333 MHz	3M Bit	4M Bit	1.2 V/3.3 V	136-Ball CSP_BGA	BC-136
ADSP-21364BSWZ-1AA <sup>3</sup>	-40°C to +85°C	333 MHz	3M Bit	4M Bit	1.2 V/3.3 V	144-Lead LQFP_EP	SW-144-1
ADSP-21364WBSWZ-1A <sup>3, 4</sup>	-40°C to +85°C	333 MHz	3M Bit	4M Bit	1.2 V/3.3 V	144-Lead LQFP_EP	SW-144-1
ADSP-21364YSWZ-2AA <sup>3</sup>	-40°C to +105°C	200 MHz	3M Bit	4M Bit	1.0 V/3.3 V	144-Lead LQFP_EP	SW-144-1
ADSP-21364WYSWZ-2A <sup>3, 4</sup>	-40°C to +105°C	200 MHz	3M Bit	4M Bit	1.0 V/3.3 V	144-Lead LQFP_EP	SW-144-1
ASDP-21365KBC-1AA <sup>2, 5, 6</sup>	0°C to +70°C	333 MHz	3M Bit	4M Bit	1.2 V/3.3 V	136-Ball CSP_BGA	BC-136
ASDP-21365KBCZ-1AA <sup>2, 3, 5, 6</sup>	0°C to +70°C	333 MHz	3M Bit	4M Bit	1.2 V/3.3 V	136-Ball CSP_BGA	BC-136
ASDP-21365BBC-1AA <sup>2, 5, 6</sup>	-40°C to +85°C	333 MHz	3M Bit	4M Bit	1.2 V/3.3 V	136-Ball CSP_BGA	BC-136
ASDP-21365BBCZ-1AA <sup>2, 3, 5, 6</sup>	-40°C to +85°C	333 MHz	3M Bit	4M Bit	1.2 V/3.3 V	136-Ball CSP_BGA	BC-136
ASDP-21365WBBCZ-1A <sup>2, 3, 5, 6</sup>	-40°C to +85°C	333 MHz	3M Bit	4M Bit	1.2 V/3.3 V	136-Ball CSP_BGA	BC-136
ADSP-21365BSWZ-1AA <sup>2, 3, 5, 6</sup>	-40°C to +85°C	333 MHz	3M Bit	4M Bit	1.2 V/3.3 V	144-Lead LQFP_EP	SW-144-1
ADSP-21365WBSWZ-1A <sup>2, 4, 5, 6</sup>	-40°C to +85°C	333 MHz	3M Bit	4M Bit	1.2 V/3.3 V	144-Lead LQFP_EP	SW-144-1
ADSP-21365YSWZ-2AA <sup>2, 3, 5, 6</sup>	-40°C to +105°C	200 MHz	3M Bit	4M Bit	1.0 V/3.3 V	144-Lead LQFP_EP	SW-144-1
ADSP-21365YSWZ-2CA <sup>2, 3, 5, 6</sup>	-40°C to +105°C	200 MHz	3M Bit	4M Bit	1.0 V/3.3 V	144-Lead LQFP_EP	SW-144-1
ADSP-21365WYSWZ-2A <sup>2, 3, 5, 6</sup>	-40°C to +105°C	200 MHz	3M Bit	4M Bit	1.0 V/3.3 V	144-Lead LQFP_EP	SW-144-1
ADSP-21365WYSWZ-2C <sup>2, 3, 4, 5, 6</sup>	-40°C to +105°C	200 MHz	3M Bit	4M Bit	1.0 V/3.3 V	144-Lead LQFP_EP	SW-144-1

# ADSP-21362/ADSP-21363/ADSP-21364/ADSP-21365/ADSP-21366

Model	Temperature Range <sup>1</sup>	Instruction Rate	On-Chip SRAM	ROM	Operating Voltage Internal/ External	Package Description	Package Option
ADSP-21366KBC-1AA <sup>5, 6</sup>	0°C to +70°C	333 MHz	3M Bit	4M Bit	1.2 V/3.3 V	136-Ball CSP_BGA	BC-136
ADSP-21366KBCZ-1AA <sup>3, 5, 6</sup>	0°C to +70°C	333 MHz	3M Bit	4M Bit	1.2 V/3.3 V	136-Ball CSP_BGA	BC-136
ADSP-21366KSWZ-1AA <sup>3, 5, 6</sup>	0°C to +70°C	333 MHz	3M Bit	4M Bit	1.2 V/3.3 V	144-Lead LQFP_EP	SW-144-1
ADSP-21366BBC-1AA <sup>5, 6</sup>	-40°C to +85°C	333 MHz	3M Bit	4M Bit	1.2 V/3.3 V	136-Ball CSP_BGA	BC-136
ADSP-21366BBCZ-1AA <sup>3, 5, 6</sup>	-40°C to +85°C	333 MHz	3M Bit	4M Bit	1.2 V/3.3 V	136-Ball CSP_BGA	BC-136
ADSP-21366WBBCZ-1A <sup>3, 5, 6</sup>	-40°C to +85°C	333 MHz	3M Bit	4M Bit	1.2 V/3.3 V	136-Ball CSP_BGA	BC-136
ADSP-21366BSWZ-1AA <sup>3, 5, 6</sup>	-40°C to +85°C	333 MHz	3M Bit	4M Bit	1.2 V/3.3 V	144-Lead LQFP_EP	SW-144-1
ADSP-21366WBSWZ-1A <sup>3, 4, 5, 6</sup>	-40°C to +85°C	333 MHz	3M Bit	4M Bit	1.2 V/3.3 V	144-Lead LQFP_EP	SW-144-1
ADSP-21366YSWZ-2AA <sup>3, 5, 6</sup>	-40°C to +105°C	200 MHz	3M Bit	4M Bit	1.0 V/3.3 V	144-Lead LQFP_EP	SW-144-1
ADSP-21366WYSWZ-2A <sup>3, 4, 5, 6</sup>	-40°C to +105°C	200 MHz	3M Bit	4M Bit	1.0 V/3.3 V	144-Lead LQFP_EP	SW-144-1

<sup>1</sup>Referenced temperature is ambient temperature.

<sup>2</sup>License from DTLA required for these products.

<sup>3</sup>Z = RoHS compliant part.

<sup>4</sup>W = For quoting purposes only. Contact local sales office for specific ordering information.

<sup>5</sup>Available with a wide variety of audio algorithm combinations sold as part of a chipset and bundled with necessary software. For a complete list, visit our website at [www.analog.com/SHARC](http://www.analog.com/SHARC).

<sup>6</sup>License from Dolby Laboratories, Inc. and Digital Theater Systems (DTS) required for these products.



**ADSP-21362/ADSP-21363/ADSP-21364/ADSP-21365/ADSP-21366**