Ordering Information

MF432	TO-46 Package
MF432 ST	ST Housing
MF432 SC	SC Housing
MF432 SMA	SMA Housing
MF432 FC	FC Housing
MF432 PT	Pig-Tail including 1 Meter of 10/125mm fibre and SC connector

-40°C to +85°C

Note: The rated Responsivity applies to all options.

Features

- 1300-1550 nm PIN Photodiode
- 2.5 GHz Bandwidth
- Designed for Single-mode and Multi-mode Fiber
- Tested to Bellcore TA-NWT-000983

Applications

- ATM-SDH/Sonet 155, 622 and 2488 Mbps
- FDDI
- ESCON
- General Purpose

Description

Tested to Bellcore TA-NWT-000983, this very high speed and low capacitance InGaAs PIN Photodiode is ideal for datacom, telecom and general purpose applications. Its double-lens optical system is designed for single-mode fiber as well as for multimode fiber with core diameter up to 62.5 μm and when used in the Pigtail-3A package, the optical return loss is very high.

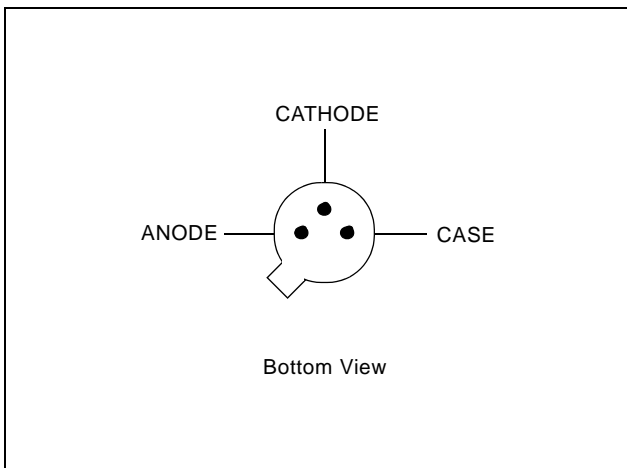
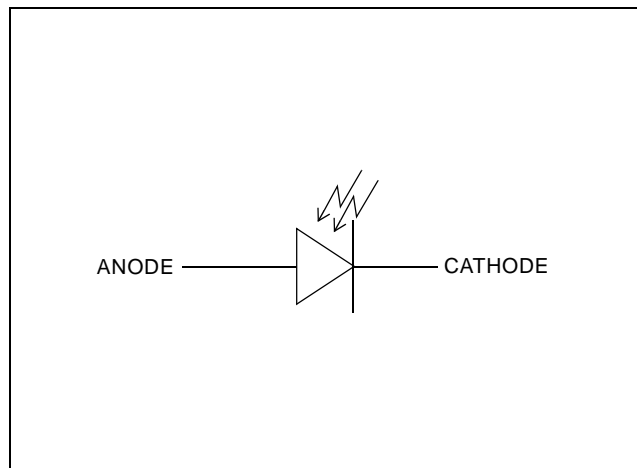
Figure 1 - Pin Diagram

Figure 2 - Functional Schematic

Optical and Electrical Characteristics - (Case Temperature -40 to +85°C)

Parameter	Symbol	Min.	Typ.	Max.	Unit	Test Condition
Responsivity (Figures 3 and 4) (Table 1)	R	0.7 0.8	0.8 1.0		A/W	$\lambda = 1300 \text{ nm}$ $\lambda = 1550 \text{ nm}$
Bandwidth	f_c	2.5			GHz	$R_L = 50\Omega$
Capacitance (Figure 4)	C		0.8	1.2	pF	$f = 1 \text{ MHz}$
Dark Current	I_d			3 80	nA	$T_{\text{Case}} = 25^\circ\text{C}$ $T_{\text{Case}} = 85^\circ\text{C}$

Note: Operating Conditions: Fiber: Single-mode 10/125 μm to multimode 62.5/125 μm . $V_R = 5 \text{ V}$

Absolute Maximum Ratings

Parameter	Symbol	Limit
Storage Temperature	T_{stg}	-55 to +125°C
Operating Temperature	T_{op}	-40 to +85°C
Reverse Voltage	V_R	20 V
Soldering Temperature (2 mm from the case for 10 sec.)	T_{slid}	260°C
ESD Resistance	V_{ESD}	+/-100 V

Thermal Characteristics

Parameter	Symbol	Min.	Typ.	Max.	Unit
Thermal Resistance - Dark Current	dI_d/dT_j		5	100	%/°C

Typical Responsivity

Core Diameter/Cladding Diameter Numerical Aperture			
	10/125 μm 0.11	50/125 μm 0.20	62.5/125 μm 0.275
1300	0.8 A/W	0.8 A/W	0.8 A/W
1500	1.0 A/W	1.0 A/W	1.0 A/W



Figure 3 - z - Axial Displacement of Fiber

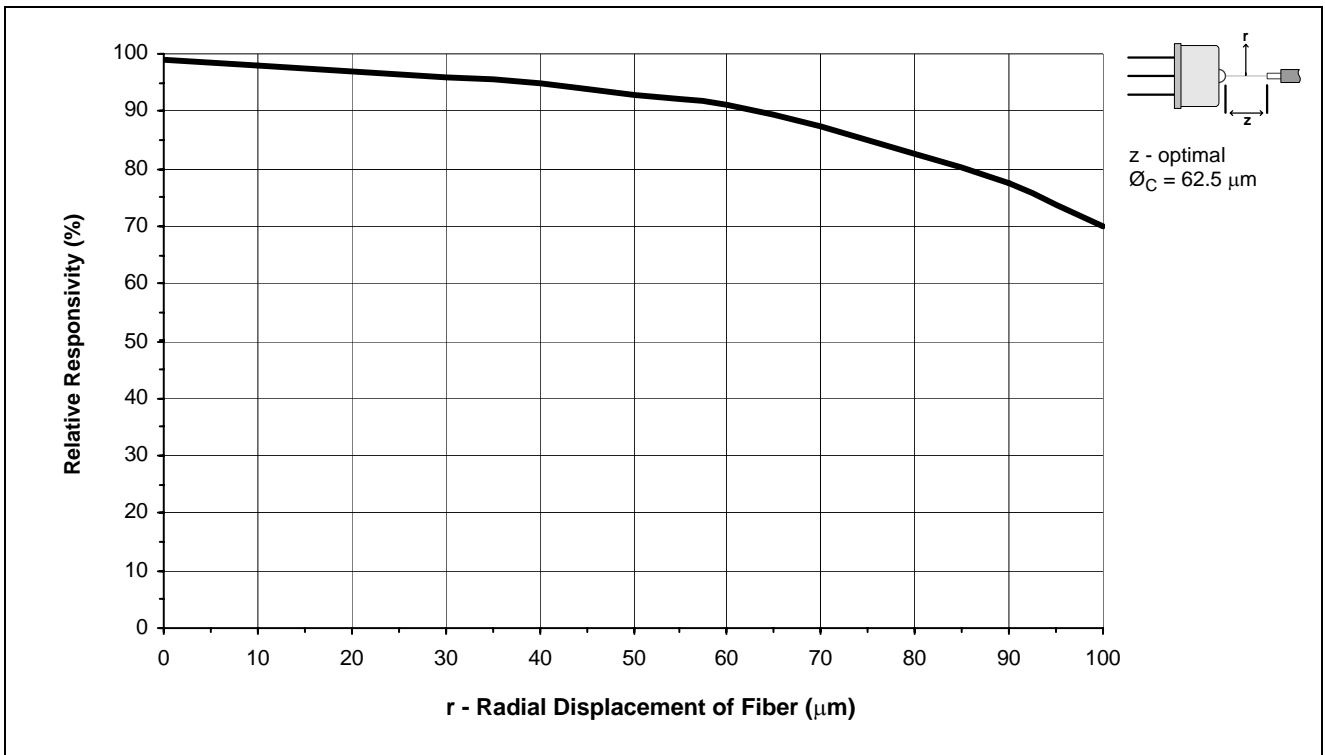

Figure 4 - r - Radial Displacement of Fiber

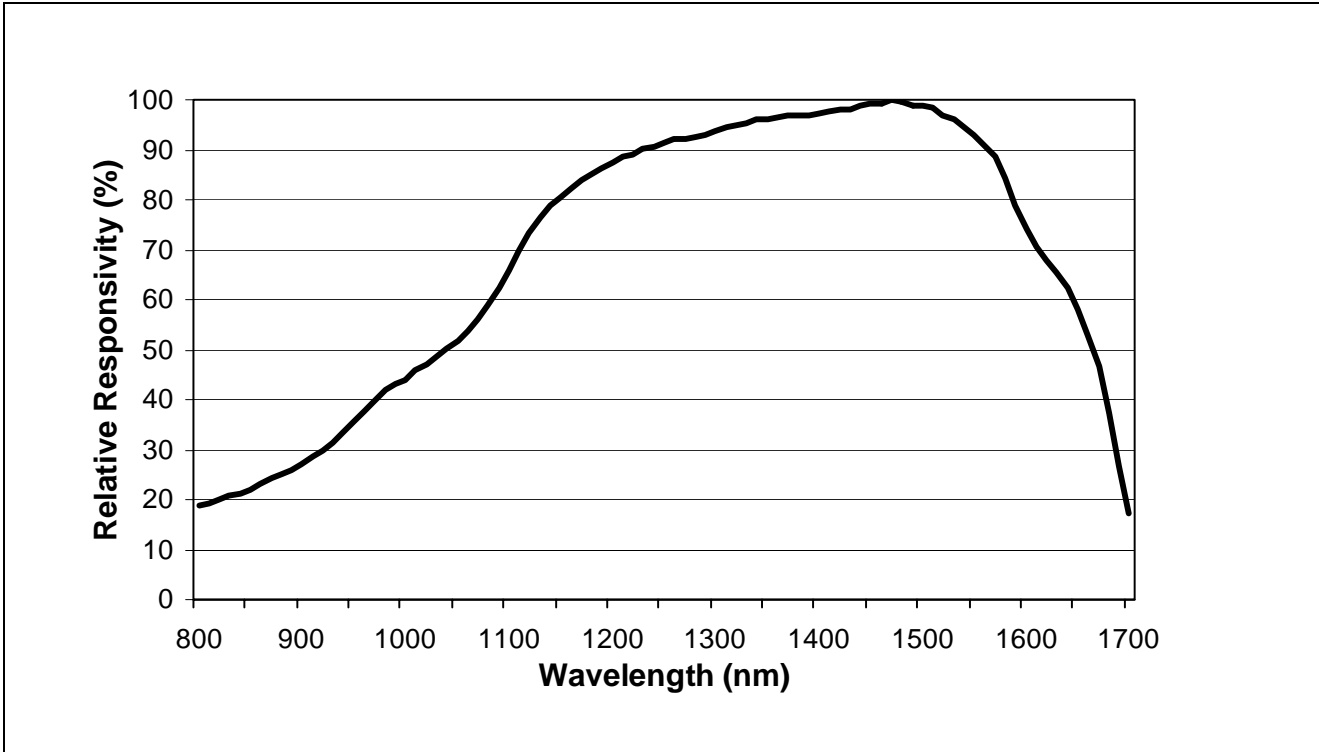

Figure 5 - Relative Responsivity vs. Wavelength

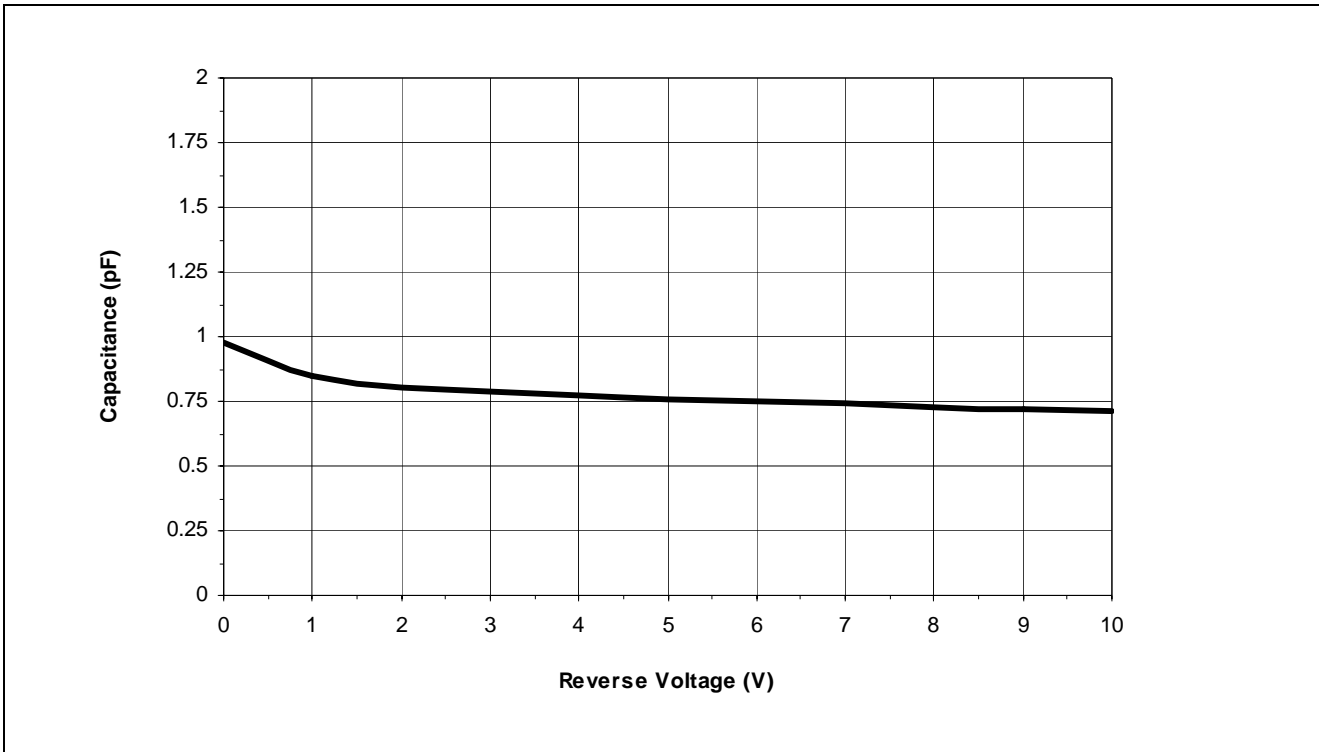
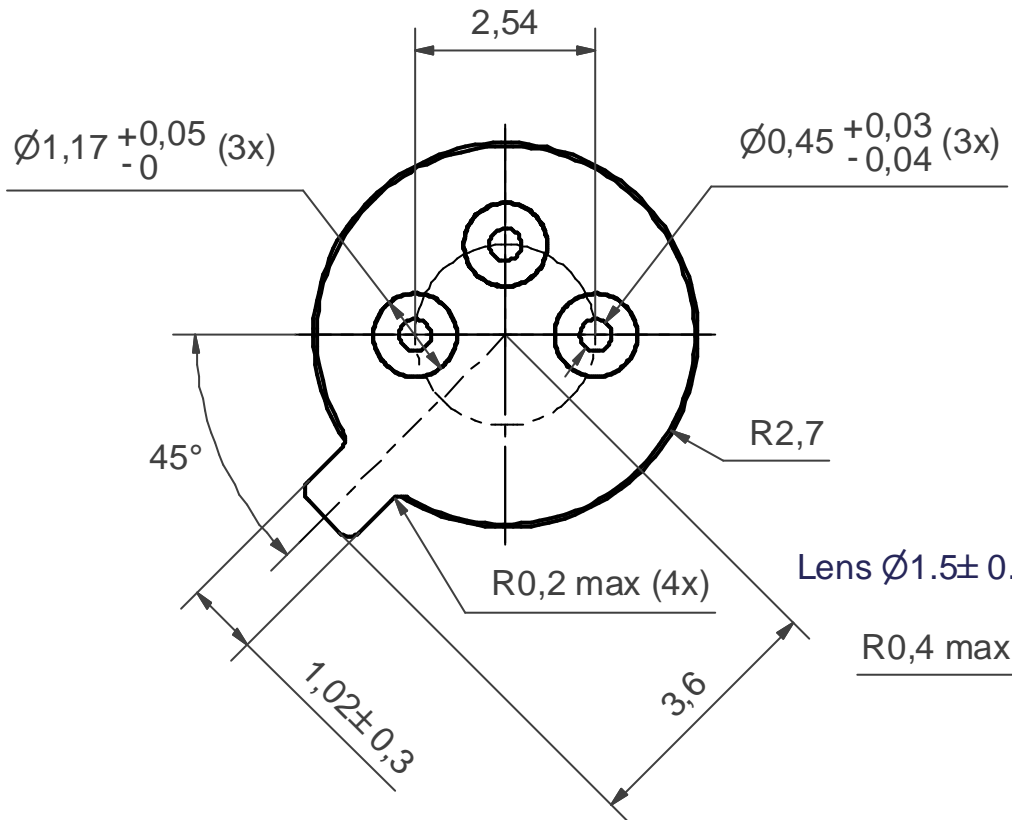
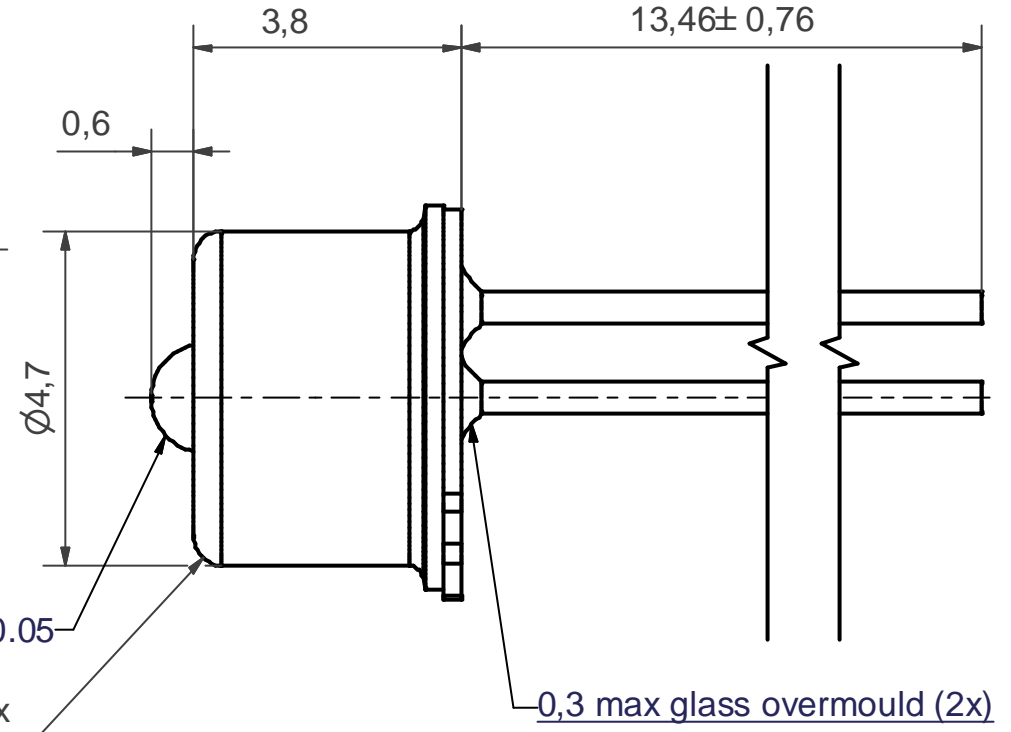

Figure 6 - Capacitance vs. Reverse Voltage

BOTTOM VIEW (10 : 1)



SIDE VIEW



NOTES:-

1. All dimensions in mm.
2. General tol. ISO-2768-mK.
3. Coating: Case: Ni 1,5-2,5 μm .
Header: Ni 2-3 μm / Au min 1,32 μm .

© Zarlink Semiconductor 2002. All rights reserved.

ISSUE	1			
ACN	JS004076R1A			
DATE	22-MAR-03			
APPRD.	TD/BE			



Package code **TB**

Previous package codes

Drawing type
Package drawing, TO-46 with lens

Title **JS004076**



**For more information about all Zarlink products
visit our Web Site at
www.zarlink.com**

Information relating to products and services furnished herein by Zarlink Semiconductor Inc. or its subsidiaries (collectively "Zarlink") is believed to be reliable. However, Zarlink assumes no liability for errors that may appear in this publication, or for liability otherwise arising from the application or use of any such information, product or service or for any infringement of patents or other intellectual property rights owned by third parties which may result from such application or use. Neither the supply of such information or purchase of product or service conveys any license, either express or implied, under patents or other intellectual property rights owned by Zarlink or licensed from third parties by Zarlink, whatsoever. Purchasers of products are also hereby notified that the use of product in certain ways or in combination with Zarlink, or non-Zarlink furnished goods or services may infringe patents or other intellectual property rights owned by Zarlink.

This publication is issued to provide information only and (unless agreed by Zarlink in writing) may not be used, applied or reproduced for any purpose nor form part of any order or contract nor to be regarded as a representation relating to the products or services concerned. The products, their specifications, services and other information appearing in this publication are subject to change by Zarlink without notice. No warranty or guarantee express or implied is made regarding the capability, performance or suitability of any product or service. Information concerning possible methods of use is provided as a guide only and does not constitute any guarantee that such methods of use will be satisfactory in a specific piece of equipment. It is the user's responsibility to fully determine the performance and suitability of any equipment using such information and to ensure that any publication or data used is up to date and has not been superseded. Manufacturing does not necessarily include testing of all functions or parameters. These products are not suitable for use in any medical products whose failure to perform may result in significant injury or death to the user. All products and materials are sold and services provided subject to Zarlink's conditions of sale which are available on request.

Purchase of Zarlink's I²C components conveys a licence under the Philips I²C Patent rights to use these components in and I²C System, provided that the system conforms to the I²C Standard Specification as defined by Philips.

Zarlink, ZL and the Zarlink Semiconductor logo are trademarks of Zarlink Semiconductor Inc.

Copyright Zarlink Semiconductor Inc. All Rights Reserved.

TECHNICAL DOCUMENTATION - NOT FOR RESALE
