

Agilent AFBR-5205Z ATM Multimode Fiber Transceivers for SONET OC-3/SDH STM-1 in Low Cost 1x9 Package Style Data Sheet

AFBR-5205Z/-5205AZ/-5205APZ/-5205ATZ/-5205PZ/-5205TZ/-5205PEZ
1300 nm 2 km

Description

The AFBR-5200Z family of transceivers from Agilent Technologies provide the system designer with products to implement a range of solutions for multimode fiber SONET OC-3 (SDH STM-1) physical layers for ATM and other services.

These transceivers are all supplied in the new industry standard 1x9 SIP package style with either a duplex SC or a duplex ST* connector interface.

ATM 2000 m Backbone Links

The AFBR-5205Z/-5205TZ are 1300 nm products with optical performance compliant with the SONET STS-3c (OC-3) Physical Layer Interface Specification. This physical layer is defined in the ATM Forum User-Network Interface (UNI) Specification Version 3.0. This document references the ANSI T1E1.2 specification for the details of the interface for 2000 meter multimode fiber backbone links.

Selected versions of these transceivers may be used to implement the ATM Forum UNI Physical Layer Interface at the 155 Mbps/194 MBd rate.

The ATM 100 Mbps/125 MBd Physical Layer interface is best implemented with the AFBR-5100Z family of FDDI Transceivers which are specified for use in this 4B/5B encoded physical layer per the FDDI PMD standard.

Transmitter Sections

The transmitter sections of the AFBR-5205Z series utilize 1300 nm InGaAsP LEDs. These LEDs are packaged in the optical subassembly portion of the transmitter section. They are driven by a custom silicon IC which converts differential PECL logic signals, ECL referenced (shifted) to a +5 Volt supply, into an analog LED drive current.

Features

- Full compliance with ATM Forum UNI SONET OC-3 Multimode Fiber Physical Layer Specification
- Multisourced 1x9 package style with choice of duplex SC or duplex ST* receptacle
- Wave solder and aqueous wash process compatibility
- RoHS Compliance

Applications

- Multimode fiber ATM backbone links
- Multimode fiber ATM wiring closet to desktop links
- ATM 155 Mbps/194 MBd encoded links (available upon special request)

Receiver Sections

The receiver sections of the AFBR-5205Z series utilize InGaAs PIN photodiodes coupled to a custom silicon transimpedance preamplifier IC. These are packaged in the optical subassembly portion of the receiver.

These PIN/preamplifier combinations are coupled to a custom quantizer IC which provides the final pulse shaping for the logic

*ST is a registered trademark of AT&T Lightguide Cable Connectors.



output and the Signal Detect function. The data output is differential. The signal detect output is single-ended. Both data and signal detect outputs are PECL compatible, ECL referenced (shifted) to a +5 volt power supply.

Package

The overall package concept for the Agilent transceivers consists of three basic elements; the two optical subassemblies, an electrical subassembly, and the housing as illustrated in the block diagrams in Figure 1 and Figure 1a.

The package outline drawing and pin out are shown in Figures 2, 2a, and 3. The details of this package outline and pin out are compliant with the multisource definition of the 1x9 SIP. The low profile of the Agilent transceiver design complies with the maximum height allowed for the duplex SC connector over the entire length of the package.

Figures 2b and 2c show the outline drawings for options that include mezzanine height and extended and flush shields respectively.

The optical subassemblies utilize a high volume assembly process together with low cost lens elements which result in a cost effective building block.

The electrical subassembly consists of a high volume multilayer printed circuit board on which the IC chips and various surface-mounted passive circuit elements are attached.

The package includes internal shields for the electrical and optical subassemblies to insure low EMI emissions and high immunity to external EMI fields.

The outer housing including the duplex SC connector or the duplex ST ports is molded of filled non-conductive plastic to provide mechanical strength and electrical isolation. The solder posts of the Agilent design are isolated from the circuit design of the transceiver and do not require connection to a ground plane on the circuit board.

The transceiver is attached to a printed circuit board with the nine signal pins and the two

solder posts which exit the bottom of the housing. The two solder posts provide the primary mechanical strength to withstand the loads imposed on the transceiver by mating with the duplex or simplex SC or ST connected fiber cables.

Note: The “T” in the product numbers indicates a transceiver with a duplex ST connector receptacle. Product numbers without a “T” indicate transceivers with a duplex SC connector receptacle.

Application Information

The Applications Engineering group in the Agilent Optical Communication Division is available to assist you with the technical understanding and design trade-offs associated with these transceivers. You can contact them through your Agilent sales representative.

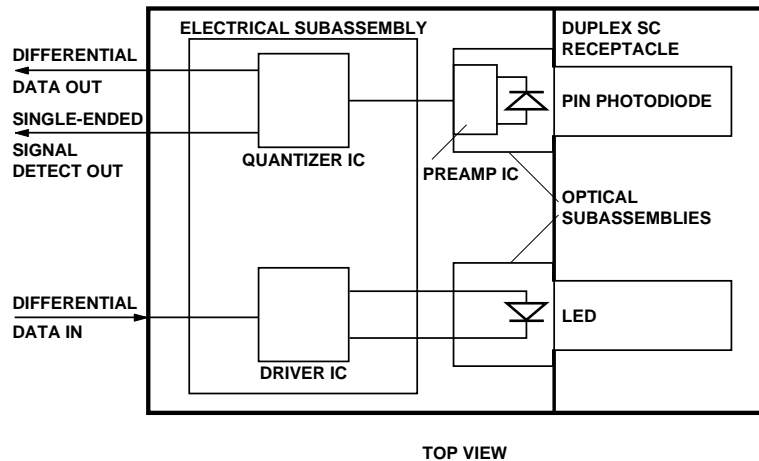

Figure 1. SC block diagram.

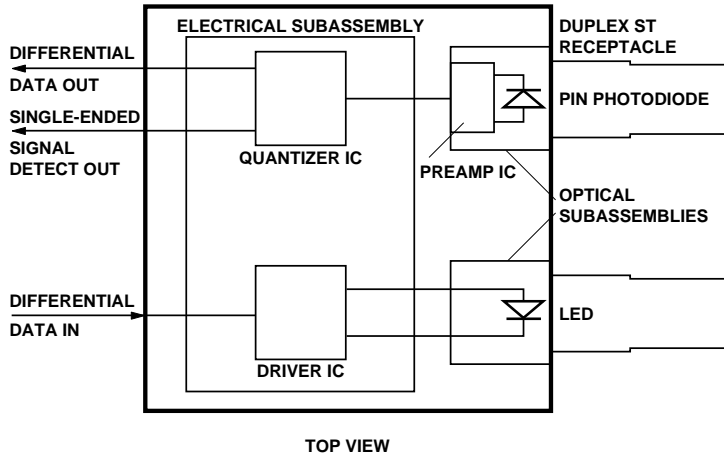

Figure 1a. ST block diagram.

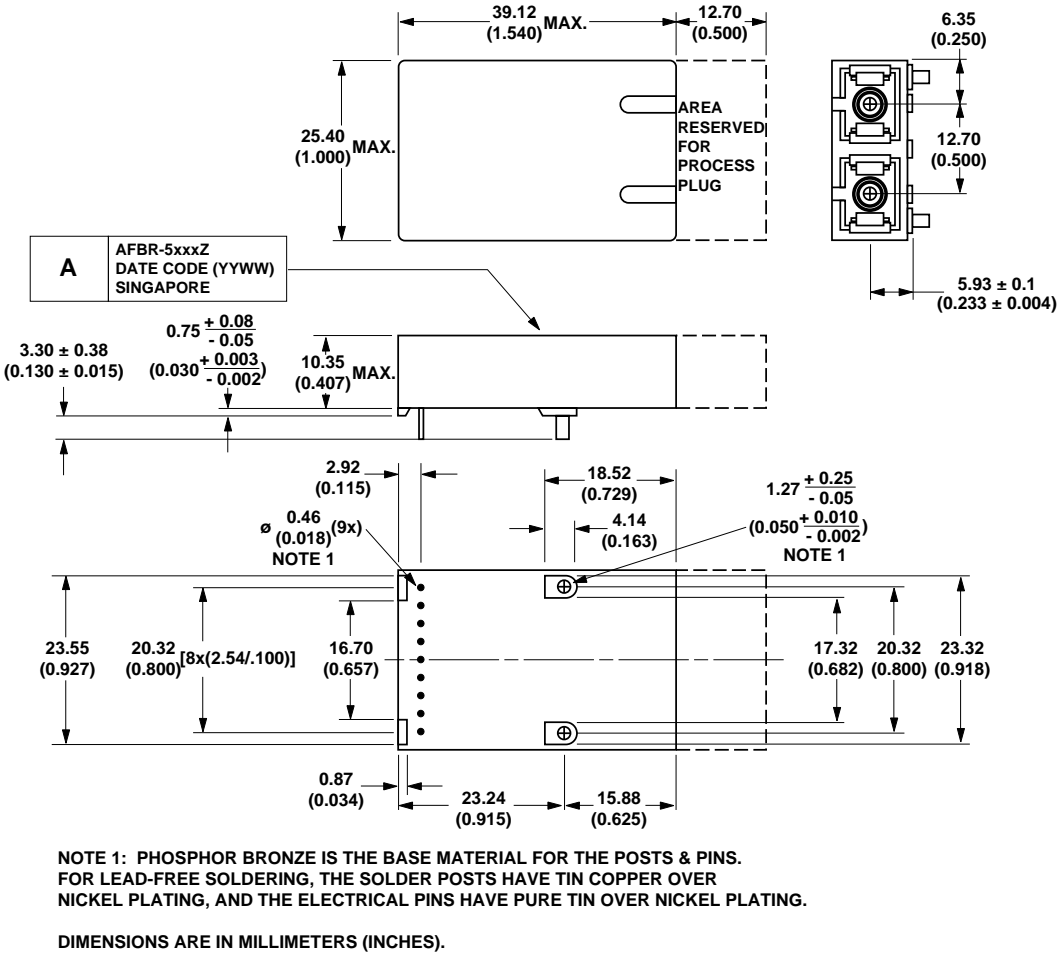
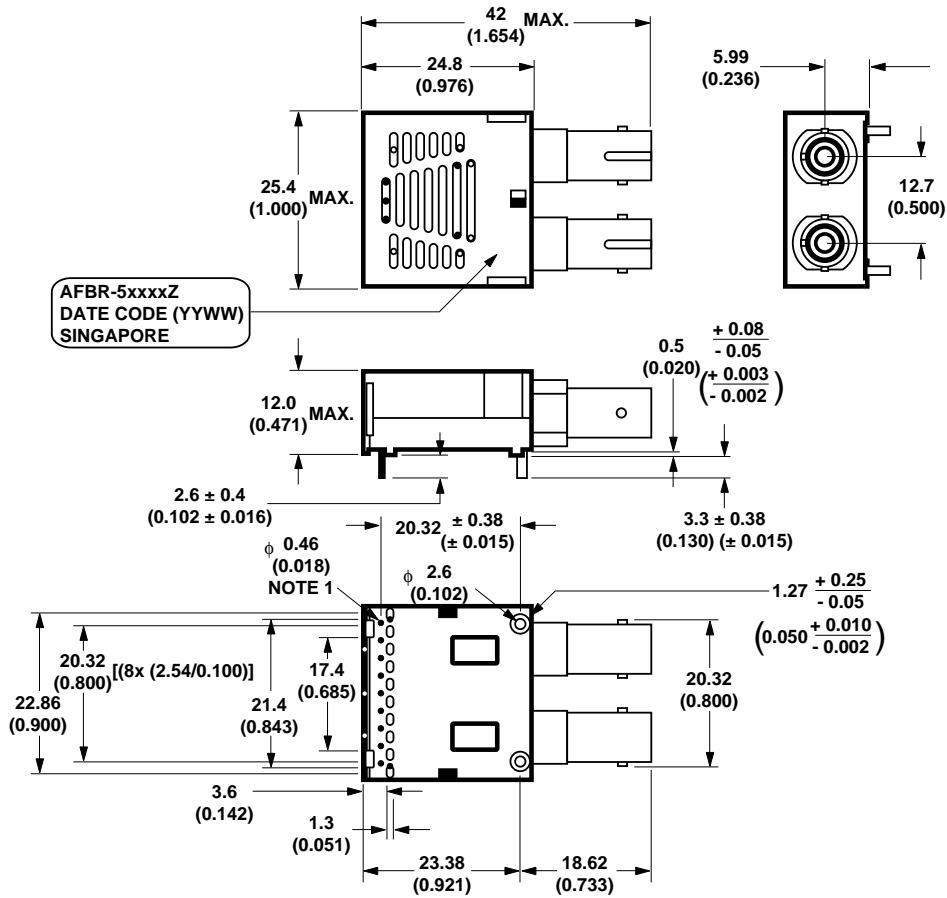

Figure 2. SC package outline drawing with standard height.



NOTE 1: PHOSPHOR BRONZE IS THE BASE MATERIAL FOR THE POSTS & PINS.
FOR LEAD-FREE SOLDERING, THE SOLDER POSTS HAVE TIN COPPER OVER
NICKEL PLATING, AND THE ELECTRICAL PINS HAVE PURE TIN OVER NICKEL PLATING.

DIMENSIONS IN MILLIMETERS (INCHES).

Figure 2a. ST package outline drawing with standard height.

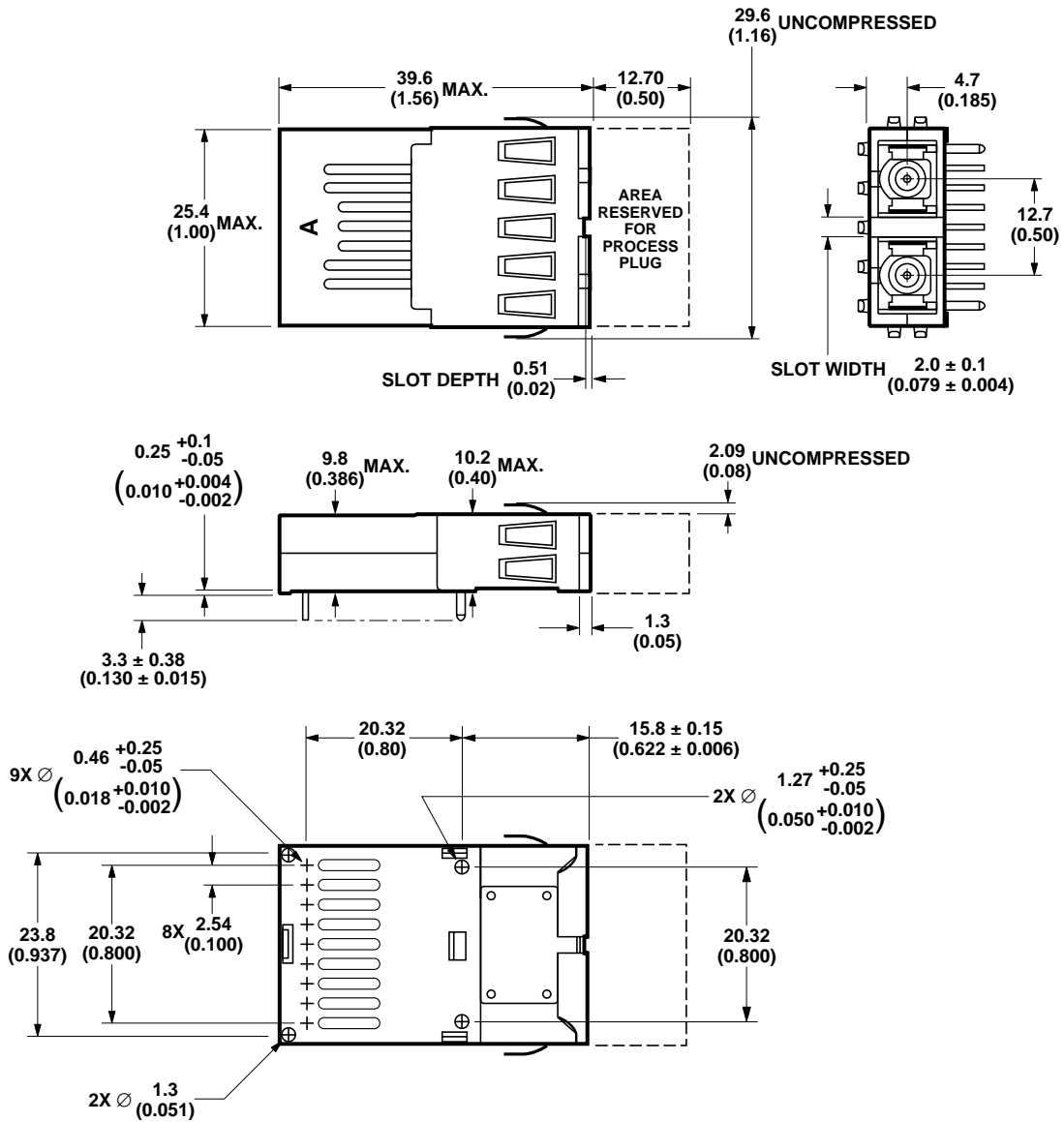

DIMENSIONS ARE IN MILLIMETERS (INCHES).
ALL DIMENSIONS ARE ± 0.025 mm UNLESS OTHERWISE SPECIFIED.

Figure 2b. Package outline drawing with mezzanine height and extended shield.

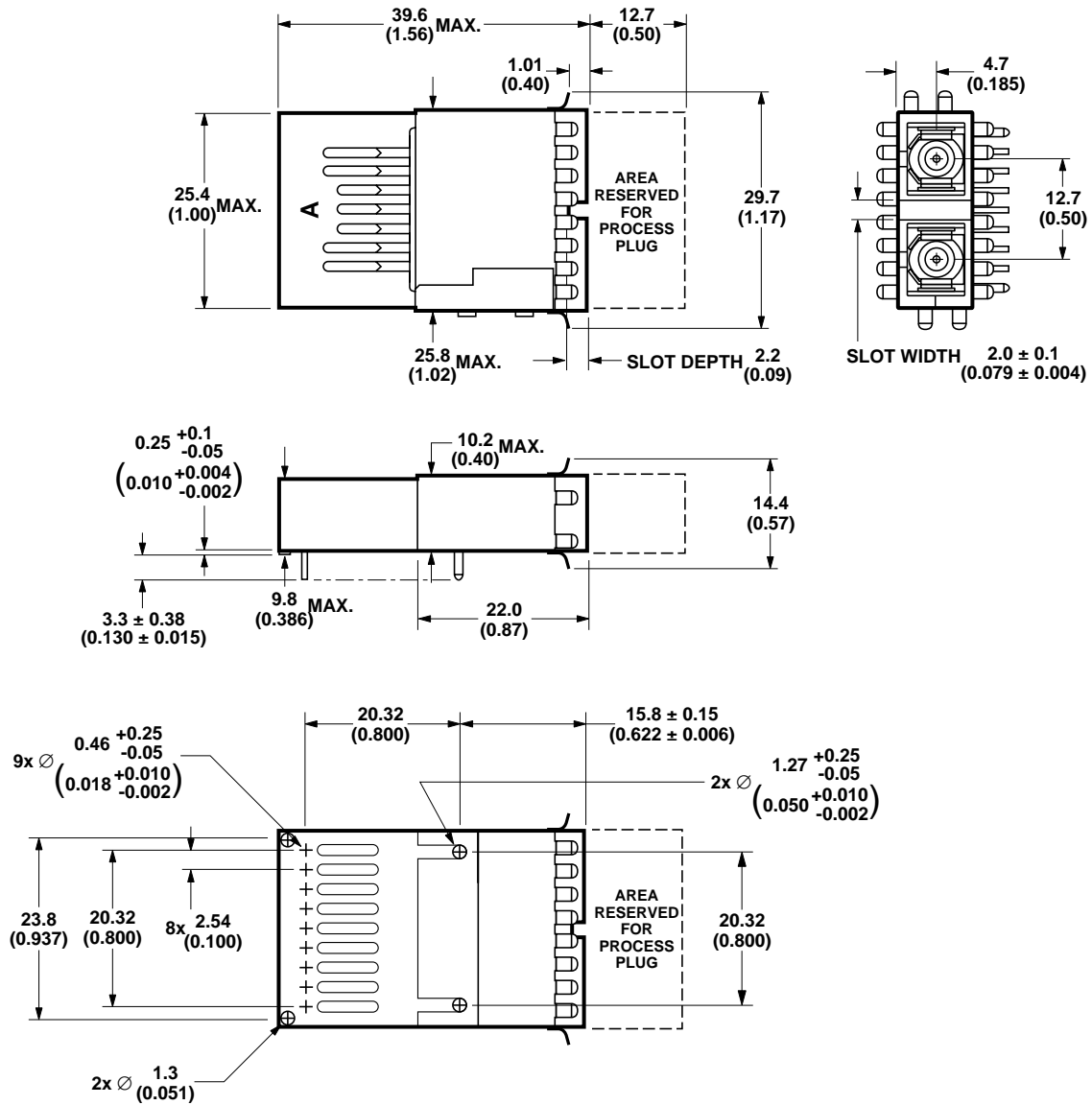

DIMENSIONS ARE IN MILLIMETERS (INCHES).
ALL DIMENSIONS ARE ± 0.025 mm UNLESS OTHERWISE SPECIFIED.

Figure 2c. Package outline drawing with mezzanine height and flush shield.

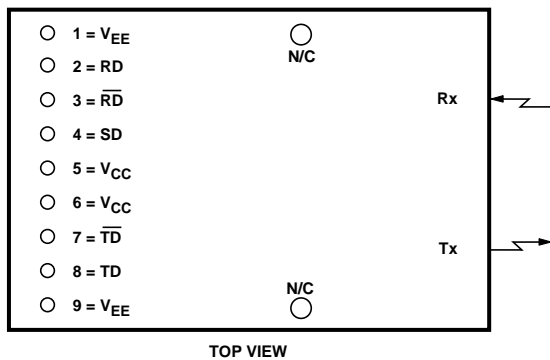

Figure 3. Pin out diagram.

The following information is provided to answer some of the most common questions about the use of these parts.

Transceiver Optical Power Budget versus Link Length

Optical Power Budget (OPB) is the available optical power for a fiber optic link to accommodate fiber cable losses plus losses due to in-line connectors, splices, optical switches, and to provide margin for link aging and unplanned losses due to cable plant reconfiguration or repair.

Figure 4 illustrates the predicted OPB associated with the three transceivers series specified in this data sheet at the Beginning of Life (BOL). These curves represent the attenuation and chromatic plus modal dispersion losses associated with the 62.5/125 μm and 50/125 μm fiber cables only. The area under the curves represents the remaining OPB at any link length, which is available for overcoming non-fiber cable losses.

Agilent LED technology has produced 1300 nm LED devices with lower aging characteristics than normally associated with

these technologies in the industry. The industry convention is 1.5 dB aging for 1300 nm LEDs. The 1300 nm Agilent LEDs are specified to experience less than 1 dB of aging over normal commercial equipment mission life periods. Contact your Agilent sales representative for additional details.

Figure 4 was generated for the 1300 nm transceivers with an Agilent fiber optic link model containing the current industry conventions for fiber cable specifications and the draft ANSI T1E1.2. These optical parameters are reflected in the guaranteed performance of the transceiver specifications in this data sheet. This same model has been used extensively in the ANSI and IEEE committees, including the ANSI T1E1.2 committee, to establish the optical performance requirements for various fiber optic interface standards. The cable parameters used come from the ISO/IEC JTC1/SC 25/WG3 Generic Cabling for Customer Premises per DIS 11801 document and the EIA/TIA-568-A Commercial Building Telecommunications Cabling Standard per SP-2840.

Transceiver Signaling Operating Rate Range and BER Performance

For purposes of definition, the symbol (Baud) rate, also called signaling rate, is the reciprocal of the symbol time. Data rate (bits/sec) is the symbol rate divided by the encoding factor used to encode the data (symbols/bit).

When used in 155 Mbps SONET OC-3 applications the performance of the 1300 nm transceivers, AFBR-5205Z is guaranteed to the full conditions listed in individual product specification tables.

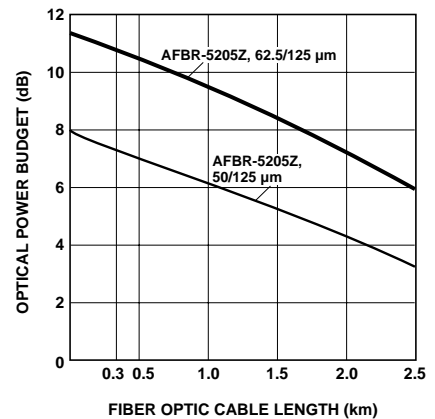

Figure 4. Optical power budget vs. fiber optic cable length.

The transceivers may be used for other applications at signaling rates different than 155 Mbps with some variation in the link optical power budget. Figure 5 gives an indication of the typical performance of these products at different rates.

These transceivers can also be used for applications which require different Bit Error Rate (BER) performance. Figure 6 illustrates the typical trade-off between link BER and the receivers input optical power level.

Transceiver Jitter Performance

The Agilent 1300 nm transceivers are designed to operate per the system jitter allocations stated in Table B1 of Annex B of the draft ANSI T1E1.2 Revision 3 standard.

The Agilent 1300 nm transmitters will tolerate the worst case input electrical jitter allowed in Annex B without violating the worst case output optical jitter requirements.

The Agilent 1300 nm receivers will tolerate the worst case input optical jitter allowed in Annex B without violating the worst case output electrical jitter allowed.

The jitter specifications stated in the following 1300 nm transceiver specification tables are derived from the values in Table B1 of Annex B. They represent the worst case jitter contribution that the transceivers are allowed to make to the overall system jitter without violating the Annex B allocation example. In practice,

the typical contribution of the Agilent transceivers is well below these maximum allowed amounts.

Recommended Handling Precautions

Agilent recommends that normal static precautions be taken in the handling and assembly of these transceivers to prevent damage which may be induced by electrostatic discharge (ESD). The AFBR-5205Z series of transceivers meet MIL-STD-883C Method 3015.4 Class 2 products.

Care should be used to avoid shorting the receiver data or signal detect outputs directly to ground without proper current limiting impedance.

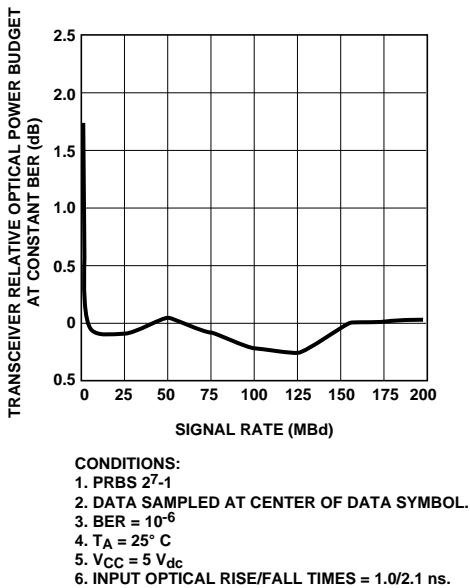

Figure 5. Transceiver relative optical power budget at constant BER vs. signaling rate.

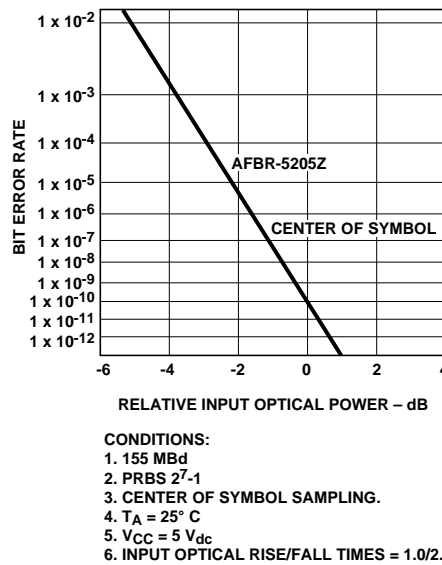

Figure 6. Bit error rate vs. relative receiver input optical power.

Solder and Wash Process Compatibility

The transceivers are delivered with protective process plugs inserted into the duplex SC or duplex ST connector receptacle. This process plug protects the optical subassemblies during

wave solder and aqueous wash processing and acts as a dust cover during shipping.

These transceivers are compatible with either industry standard wave or hand solder processes.

Shipping Container

The transceiver is packaged in a shipping container designed to protect it from mechanical and ESD damage during shipment or storage.

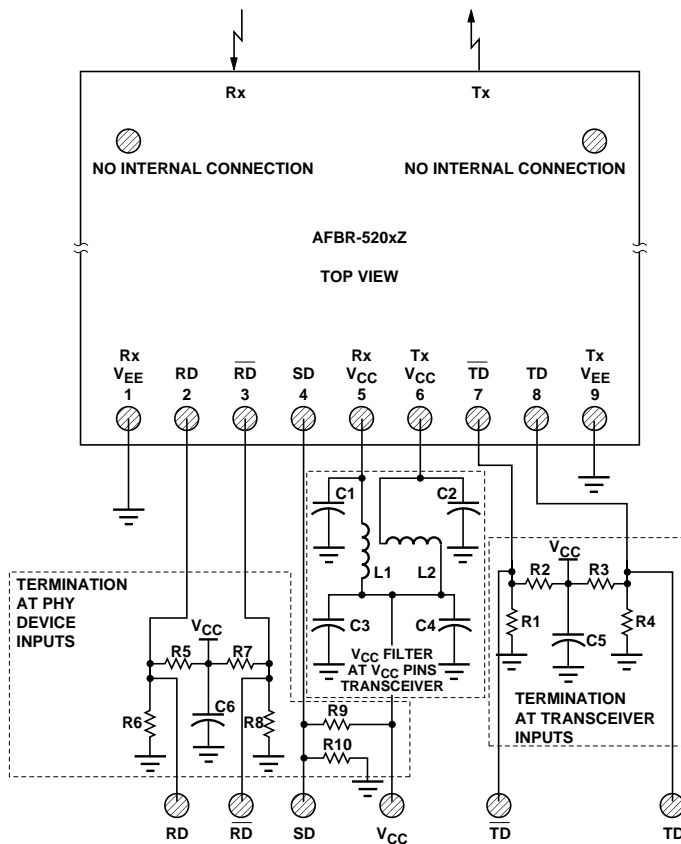

- NOTES:**
 THE SPLIT-LOAD TERMINATIONS FOR ECL SIGNALS NEED TO BE LOCATED AT THE INPUT OF DEVICES RECEIVING THOSE ECL SIGNALS. RECOMMEND 4-LAYER PRINTED CIRCUIT BOARD WITH 50 OHM MICROSTRIP SIGNAL PATHS BE USED.
- R1 = R4 = R6 = R8 = R10 = 130 OHMS.
 - R2 = R3 = R5 = R7 = R9 = 82 OHMS.
 - C1 = C2 = C3 = C5 = C6 = 0.1 μF.
 - C4 = 10 μF.
 - L1 = L2 = 1 μH COIL OR FERRITE INDUCTOR.

Figure 7. Recommended decoupling and termination circuits.

Board Layout – Decoupling Circuit and Ground Planes

It is important to take care in the layout of your circuit board to achieve optimum performance from these transceivers. Figure 7 provides a good example of a schematic for a power supply decoupling circuit that works well with these parts. It is further recommended that a contiguous ground plane be provided in the

circuit board directly under the transceiver to provide a low inductance ground for signal return current. This recommendation is in keeping with good high frequency board layout practices.

Board Layout – Hole Pattern

The Agilent transceiver complies with the circuit board “Common Transceiver Footprint” hole

pattern defined in the original multisource announcement which defined the 1x9 package style. This drawing is reproduced in Figure 8 with the addition of ANSI Y14.5M compliant dimensioning to be used as a guide in the mechanical layout of your circuit board.

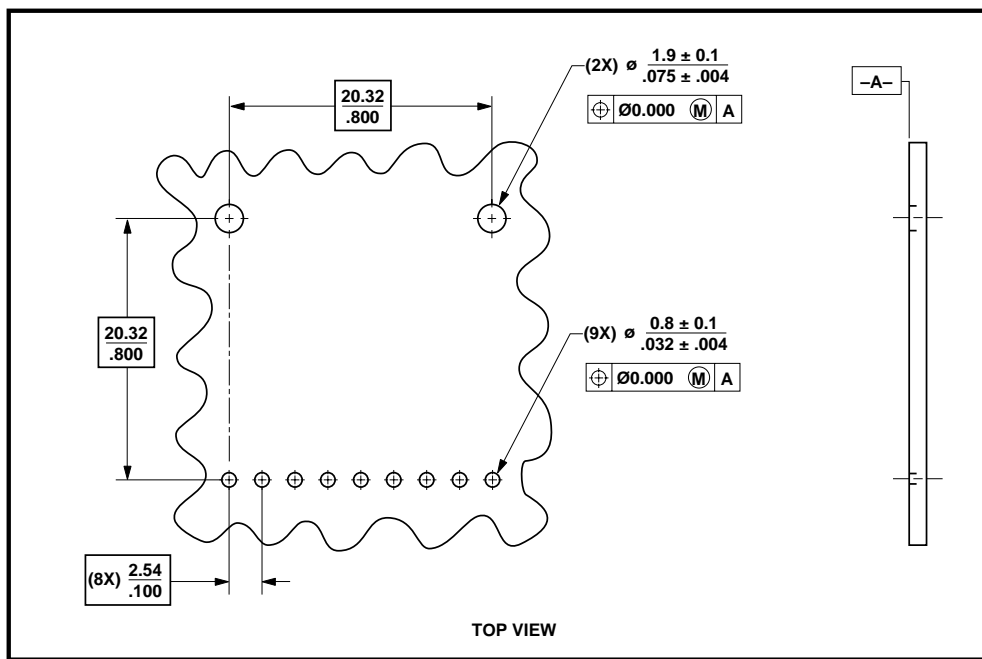

Figure 8. Recommended board layout hole pattern.

Board Layout – Mechanical

For applications interested in providing a choice of either a duplex SC or a duplex ST connector interface, while utilizing the same pinout on the printed circuit board, the ST port needs to protrude from the chassis panel a minimum of 9.53 mm for sufficient clearance to install the ST connector.

Please refer to Figure 8a for a mechanical layout detailing the recommended location of the duplex SC and duplex ST transceiver packages in relation to the chassis panel.

For both shielded design options, Figures 8b and 8c identify front panel aperture dimensions.

Regulatory Compliance

These transceiver products are intended to enable commercial system designers to develop equipment that complies with the various international regulations governing certification of Information Technology Equipment. See the Regulatory Compliance Table for details. Additional information is available from your Agilent sales representative.

Electrostatic Discharge (ESD)

There are two design cases in which immunity to ESD damage is important.

The first case is during handling of the transceiver prior to mounting it on the circuit board. It is important to use normal ESD handling precautions for ESD sensitive devices. These precautions include using grounded wrist straps, work benches, and floor mats in ESD controlled areas.

The second case to consider is static discharges to the exterior of the equipment chassis containing the transceiver parts. To the extent that the duplex SC connector is exposed to the outside of the equipment chassis it may be subject to whatever ESD system level test criteria that the equipment is intended to meet.

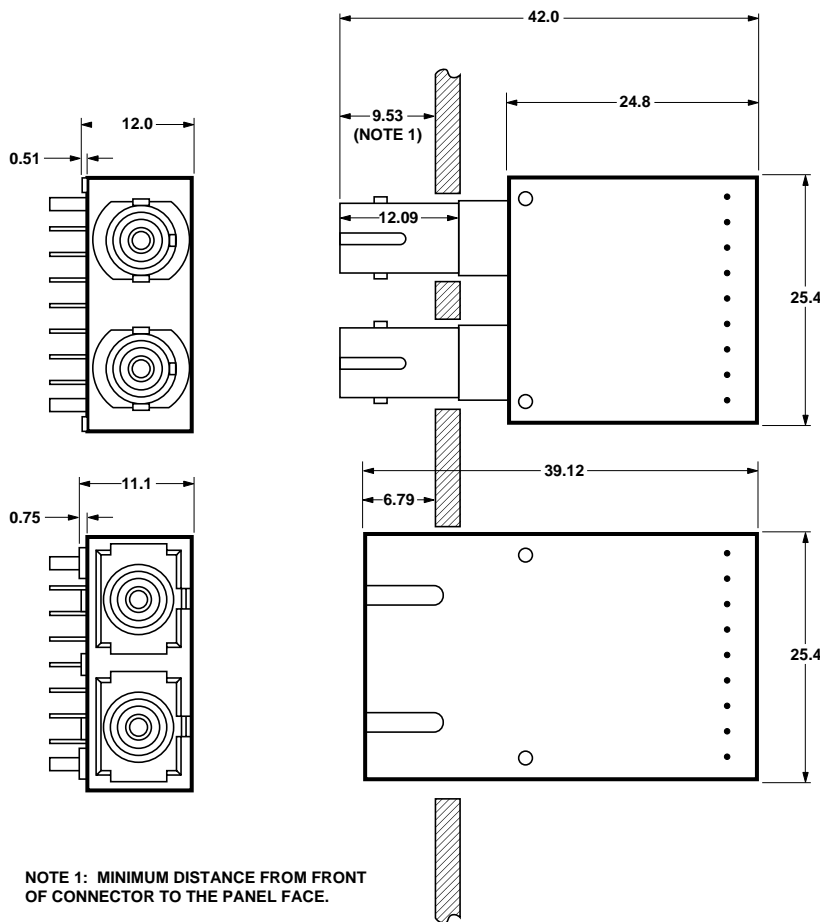
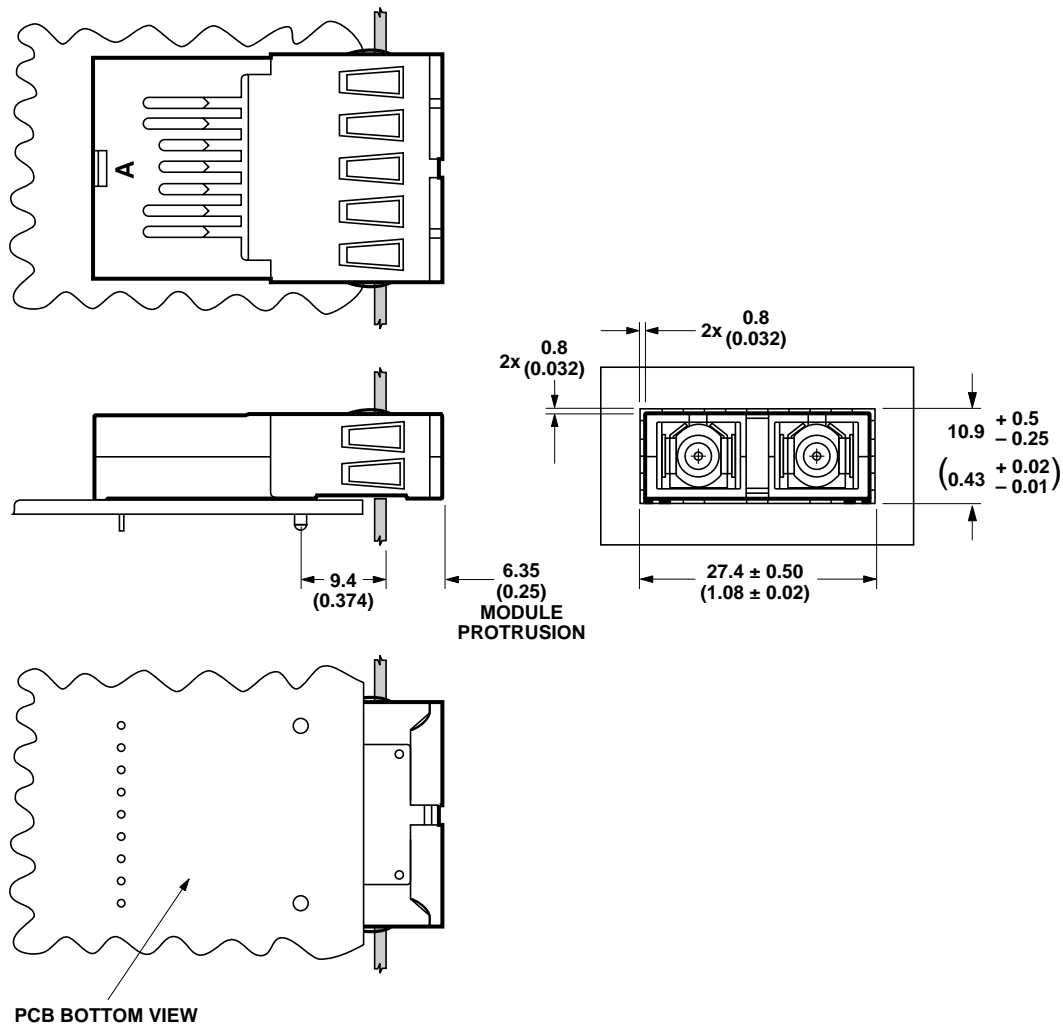

Figure 8a. Recommended common mechanical layout for ST and ST 1x9 connected transceivers.



DIMENSIONS ARE IN MILLIMETERS (INCHES).
ALL DIMENSIONS ARE ± 0.025 mm UNLESS OTHERWISE SPECIFIED.

Figure 8b. Dimensions shown for mounting module with extended shield to panel.

Electromagnetic Interference (EMI)

Most equipment designs utilizing these high speed transceivers from Agilent will be required to meet the requirements of FCC in the United States, CENELEC EN55022 (CISPR 22) in Europe and VCCI in Japan.

These products are suitable for use in designs ranging from a desktop computer with a single transceiver to a concentrator or switch product with large number of transceivers.

In all well-designed chassis, the two 0.5" holes required for ST

connectors to protrude through, will provide 4.6 dB more shielding than one 1.2" duplex SC rectangular cutout. Thus, in a well-designed chassis, the duplex ST 1x9 transceiver emissions will be identical to the duplex SC 1x9 transceiver emissions.

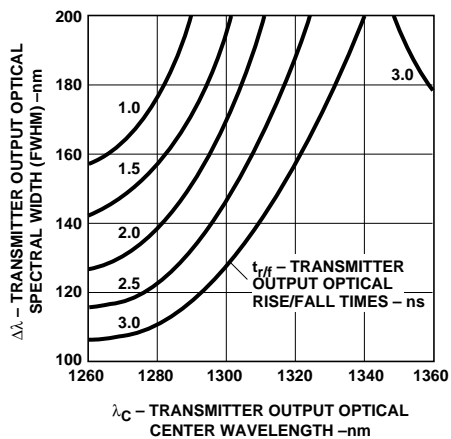

AFBR-5205Z TRANSMITTER TEST RESULTS OF λ_C , $\Delta\lambda$ AND $t_{r/f}$ ARE CORRELATED AND COMPLY WITH THE ALLOWED SPECTRAL WIDTH AS A FUNCTION OF CENTER WAVELENGTH FOR VARIOUS RISE AND FALL TIMES.

Figure 9. Transmitter output optical spectral width (FWHM) vs. transmitter output optical wavelength and rise/fall times.

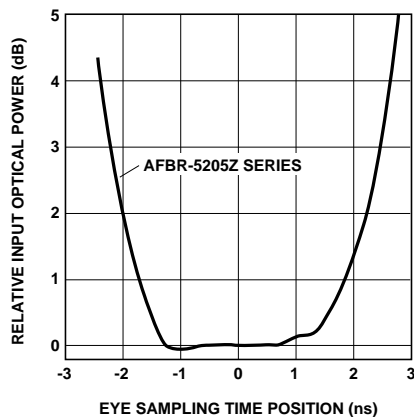

CONDITIONS:
 1. $T_A = 25^\circ\text{C}$
 2. $V_{CC} = 5\text{ Vdc}$
 3. INPUT OPTICAL RISE/FALL TIMES = 1.0/2.1 ns.
 4. INPUT OPTICAL POWER IS NORMALIZED TO CENTER OF DATA SYMBOL.
 5. NOTE 16 AND 17 APPLY.

Figure 10. Relative input optical power vs. eye sampling time position.

Regulatory Compliance Table

Feature	Test Method	Performance
Electrostatic Discharge (ESD) to the Electrical Pins	MIL-STD-883C Method 3015.4	Meets Class 2 (2000 to 3999 Volts) Withstand up to 2200 V applied between electrical pins.
Electrostatic Discharge (ESD) to the Duplex SC Receptacle	Variation of IEC 801-2	Typically withstand at least 25 kV without damage when the Duplex SC Connector Receptacle is contacted by a Human Body Model probe.
Electromagnetic Interference (EMI)	FCC Class B CENELEC EN55022 Class B (CISPR 22B) VCCI Class 2	Typically provide 13dB margin to the noted standards however, it should be noted that final margin depends on the customer's board and chassis design.
Immunity	Variation of IEC 61000-4-3	Typically show no measurable effect from a 10 V/m field swept from 10 to 450 MHz applied to the transceiver when mounted to a circuit card without a chassis enclosure.

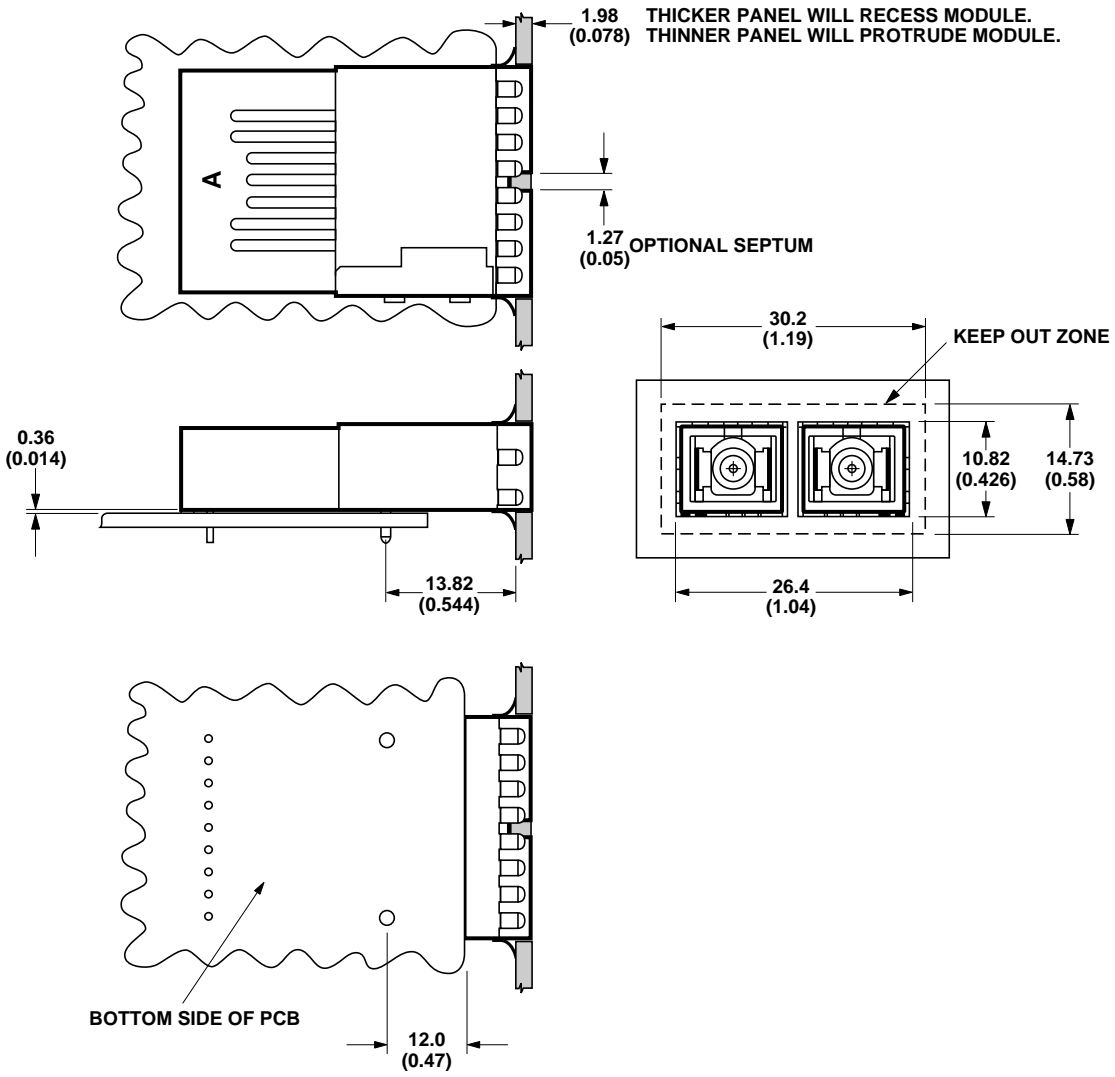

DIMENSIONS ARE IN MILLIMETERS (INCHES).
ALL DIMENSIONS ARE ± 0.025 mm UNLESS OTHERWISE SPECIFIED.

Figure 8c. Dimensions shown for mounting module flush to panel.

Immunity

Equipment utilizing these transceivers will be subject to radio-frequency electromagnetic fields in some environments. These transceivers have a high immunity to such fields.

For additional information regarding EMI, susceptibility, ESD and conducted noise testing procedures and results on the 1x9 transceiver family, please refer to Applications Note 1075, Testing and Measuring Electromagnetic Compatibility Performance of the AFBR-510XZ/-520XZ Fiber Optic Transceivers.

Transceiver Reliability and Performance Qualification Data

The 1x9 transceivers have passed Agilent reliability and performance qualification testing and are undergoing ongoing quality monitoring. Details are available from your Agilent sales representative.

These transceivers are manufactured at the Agilent Singapore location which is an ISO 9002 certified facility.

Applications Support Materials

Contact your local Agilent Component Field Sales Office for information on how to obtain Test Boards and demo boards for the 1x9 transceivers.

Evaluation Kits

Agilent has available three evaluation kits for the 1x9 transceivers. The purpose of these kits is to provide the necessary materials to evaluate the performance of the AFBR-520XZ family in a pre-existing 1x13 or 2x11 pinout system design configuration or when connected to various test equipment.

1. HFBR-0319 – Evaluation Test Fixture Board:
This test fixture converts +5 V ECL 1x9 transceivers to –5 V

ECL BNC Coax Connections so that direct connections to industry standard fiber optic test equipment can be accomplished.

Accessory Duplex SC Connected Cable Assemblies

Agilent recommends for optimal coupling the use of flexible-body duplex SC connected cable.

Accessory Duplex ST Connected Cable Assemblies

Agilent recommends the use of Duplex Push-Pull ST connected cable for optimal repeatability of the optical power coupling.

AFBR-5205Z Series**Absolute Maximum Ratings**

Parameter	Symbol	Min.	Typ.	Max.	Unit	Reference
Storage Temperature	T_S	-40		100	°C	
Lead Soldering Temperature	T_{SOLD}			260	°C	
Lead Soldering Time	t_{SOLD}			10	sec.	
Supply Voltage	V_{CC}	-0.5		7.0	V	
Data Input Voltage	V_I	-0.5		V_{CC}	V	
Differential Input Voltage	V_D			1.4	V	Note 1
Output Current	I_O			50	mA	

AFBR-5205Z Series**Recommended Operating Conditions**

Parameter	Symbol	Min.	Typ.	Max.	Unit	Reference
Ambient Operating Temperature*	T_A	0		70	°C	
Supply Voltage	V_{CC}	4.75		5.25	V	
Data Input Voltage - Low	$V_{IL} - V_{CC}$	-1.810		-1.475	V	
Data Input Voltage - High	$V_{IH} - V_{CC}$	-1.165		-0.880	V	
Data and Signal Detect Output Load	R_L		50		Ω	Note 2

*Applies to AFBR-5205Z Series except for AFBR-5205AZ and AFBR-5205ATZ. Ambient Operating Temp. for AFBR-5205AZ and AFBR-5205ATZ is Min. -40°C and Max. 85°C.

AFBR-5205Z Series**Transmitter Electrical Characteristics**(T_A = 0°C to 70°C, V_{CC} = 4.75 V to 5.25 V)*

Parameter	Symbol	Min.	Typ.	Max.	Unit	Reference
Supply Current	I _{CC}		145	185	mA	Note 3
Power Dissipation	P _{DISS}		0.76	0.97	W	
Data Input Current - Low	I _{IL}	-350	0		μA	
Data Input Current - High	I _{IH}		14	350	μA	

*Applies to AFBR-5205Z Series except for AFBR-5205AZ and AFBR-5205ATZ. T_A for AFBR-5205AZ and AFBR-5205ATZ is -40°C and 85°C.**AFBR-5205Z Series****Receiver Electrical Characteristics**(T_A = 0°C to 70°C, V_{CC} = 4.75 V to 5.25 V)*

Parameter	Symbol	Min.	Typ.	Max.	Unit	Reference
Supply Current	I _{CC}		82	145	mA	Note 4
Power Dissipation	P _{DISS}		0.3	0.5	W	Note 5
Data Output Voltage - Low	V _{OL} - V _{CC}	-1.83		-1.55	V	Note 6
Data Output Voltage - High	V _{OH} - V _{CC}	-1.085		-0.88	V	Note 6
Data Output Rise Time	t _r	0.35		2.2	ns	Note 7
Data Output Fall Time	t _f	0.35		2.2	ns	Note 7
Signal Detect Output Voltage - Low	V _{OL} - V _{CC}	-1.83		-1.55	V	Note 6
Signal Detect Output Voltage - High	V _{OH} - V _{CC}	-1.085		-0.88	V	Note 6
Signal Detect Output Rise Time	t _r	0.35		2.2	ns	Note 7
Signal Detect Output Fall Time	t _f	0.35		2.2	ns	Note 7

*Applies to AFBR-5205Z Series except for AFBR-5205AZ and AFBR-5205ATZ. T_A for AFBR-5205AZ and AFBR-5205ATZ is -40°C and 85°C.

AFBR-5205Z/-5205AZ/-5205ATZ/-5205PZ/-5205TZ/-5205PEZ**Transmitter Optical Characteristics**(T_A = 0°C to 70°C, V_{CC} = 4.75 V to 5.25 V)*

Parameter		Symbol	Min.	Typ.	Max.	Unit	Reference
Output Optical Power 62.5/125 μm, NA = 0.275 Fiber	BOL EOL	P ₀	-19 -20		-14	dBm avg.	Note 8
Output Optical Power 50/125 μm, NA = 0.20 Fiber	BOL EOL	P ₀	-22.5 -23.5		-14	dBm avg.	Note 8
Optical Extinction Ratio			10			dB	Note 9
Output Optical Power at Logic "0" State		P ₀ ("0")			-45	dBm avg.	Note 10
Center Wavelength		λ _c	1270	1310	1380	nm	Note 23 Figure 9
Spectral Width – FWHM – nm RMS		Δλ		137 58		nm nm RMS	Note 11, 23 Figure 9
Optical Rise Time		t _r	0.6	1.0	3.0	ns	Note 12, 23 Figure 9
Optical Fall Time		t _f	0.6	2.1	3.0	ns	Note 12, 23 Figure 9
Systematic Jitter Contributed by the Transmitter		SJ		0.04	1.2	ns p-p	Note 13
Random Jitter Contributed by the Transmitter		RJ		0	0.52	ns p-p	Note 14

*Applies to 5205Z Series except for AFBR-5205AZ/-5205ATZ. T_A for AFBR-5205AZ/-5205ATZ is -40°C and 85°C.

AFBR-5205Z/-5205AZ/-5205ATZ/-5205PZ/-5205TZ/-5205PEZ

Receiver Optical and Electrical Characteristics

($T_A = 0^\circ\text{C}$ to 70°C , $V_{CC} = 4.75\text{ V}$ to 5.25 V)*

Parameter	Symbol	Min.	Typ.	Max.	Unit	Reference
Input Optical Power Minimum at Window Edge	$P_{IN\ Min. (W)}$			-30	dBm avg.	Note 15 Figure 10
Input Optical Power Minimum at Eye Center	$P_{IN\ Min. (C)}$			-31	dBm avg.	Note 16 Figure 10
Input Optical Power Maximum	$P_{IN\ Max.}$	-14			dBm avg.	Note 15
Operating Wavelength	λ	1270		1380	nm	
Systematic Jitter Contributed by the Receiver	SJ		0.2	1.2	ns p-p	Note 17
Random Jitter Contributed by the Receiver	RJ		1	1.91	ns p-p	Note 18
Signal Detect - Asserted	P_A	$P_D + 1.5\text{ dB}$		-31	dBm avg.	Note 19
Signal Detect - Deasserted	P_D	-45			dBm avg.	Note 20
Signal Detect - Hysteresis	$P_A - P_D$	1.5			dB	
Signal Detect Assert Time (off to on)		0	55	100	μs	Note 21
Signal Detect Assert Time (off to on) for -40°C to 0°C	Max	0	55	130	μs	Note 21
Signal Detect Deassert Time (on to off)		0	110	350	μs	Note 22

*Applies to 5205Z Series except for AFBR-5205AZ. T_A for AFBR-5205AZ is -40°C to 85°C .

Notes:

- This is the maximum voltage that can be applied across the Differential Transmitter Data Inputs to prevent damage to the input ESD protection circuit.
- The outputs are terminated with $50\ \Omega$ connected to $V_{CC} - 2\text{ V}$.
- The power supply current needed to operate the transmitter is provided to differential ECL circuitry. This circuitry maintains a nearly constant current flow from the power supply. Constant current operation helps to prevent unwanted electrical noise from being generated and conducted or emitted to neighboring circuitry.
- This value is measured with the outputs terminated into $50\ \Omega$ connected to $V_{CC} - 2\text{ V}$ and an Input Optical Power level of -14 dBm average.
- The power dissipation value is the power dissipated in the receiver itself. Power dissipation is calculated as the sum of the products of supply voltage and currents, minus the sum of the products of the output voltages and currents.
- This value is measured with respect to V_{CC} with the output terminated into $50\ \Omega$ connected to $V_{CC} - 2\text{ V}$.
- The output rise and fall times are measured between 20% and 80% levels with the output connected to $V_{CC} - 2\text{ V}$ through $50\ \Omega$.
- These optical power values are measured with the following conditions:
 - The Beginning of Life (BOL) to the End of Life (EOL) optical power degradation is typically 1.5 dB per the industry convention for long wavelength LEDs. The actual degradation observed in Agilent's 1300 nm LED products is $<1\text{ dB}$, as specified in this datasheet.
 - Over the specified operating voltage and temperature ranges.
 - With 25 MBd (12.5 MHz square-wave) input signal.
 - At the end of one meter of noted optical fiber with cladding modes removed. The average power value can be converted to a peak power value by adding 3 dB . Higher output optical power transmitters are available on special request.
- The Extinction Ratio is a measure of the modulation depth of the optical signal. The data "1" peak output optical power is compared to the data "0" output optical power and expressed in decibels. With the transmitter driven by a 25 MBd (12.5 MHz square-wave) input signal, the average optical power is measured. The data "1" peak power is then calculated by adding 3 dB to the measured average optical power. The data "0" output optical power is found by measuring the optical power when the transmitter is driven by a logic "0" input. The extinction ratio is the ratio of the optical power at the "1" level compared to the optical power at the "0" level expressed in decibels.

10. The transmitter will provide this low level of Output Optical Power when driven by a logic "0" input. This can be useful in link troubleshooting.
11. The relationship between Full Width Half Maximum and RMS values for Spectral Width is derived from the assumption of a Gaussian shaped spectrum which results in a $2.35 \times \text{RMS} = \text{FWHM}$ relationship.
12. The optical rise and fall times are measured from 10% to 90% when the transmitter is driven by a 25 MBd (12.5 MHz square-wave) input signal. The ANSI T1E1.2 committee has designated the possibility of defining an eye pattern mask for the transmitter optical output as an item for further study. Agilent will incorporate this requirement into the specifications for these products if it is defined. The AFBR-5205Z products typically comply with the template requirements of CCITT (now ITU-T) G.957 Section 3.2.5, Figure 2 for the STM-1 rate, excluding the optical receiver filter normally associated with single mode fiber measurements which is the likely source for the ANSI T1E1.2 committee to follow in this matter.
13. Systematic Jitter contributed by the transmitter is defined as the combination of Duty Cycle Distortion and Data Dependent Jitter. Systematic Jitter is measured at 50% threshold using a 155.52 MBd (77.5 MHz square-wave), 2⁷ - 1 psuedorandom data pattern input signal.
14. Random Jitter contributed by the transmitter is specified with a 155.52 MBd (77.5 MHz square-wave) input signal.
15. This specification is intended to indicate the performance of the receiver section of the transceiver when Input Optical Power signal characteristics are present per the following definitions. The Input Optical Power dynamic range from the minimum level (with a window time-width) to the maximum level is the range over which the receiver is guaranteed to provide output data with a Bit Error Ratio (BER) better than or equal to 1×10^{-10} .
 - At the Beginning of Life (BOL)
 - Over the specified operating temperature and voltage ranges
 - Input is a 155.52 MBd, 2²³ - 1 PRBS data pattern with 72 "1"s and 72 "0"s inserted per the CCITT (now ITU-T) recommendation G.958 Appendix I.
 - Receiver data window time-width is 1.23 ns or greater for the clock recovery circuit to operate in. The actual test data window time-width is set to simulate the effect of worst case optical input jitter based on the transmitter jitter values from the specification tables. The test window time-width is as follows: HFBR-5205 is 3.32 ns.
 - Transmitter operating with a 155.52 MBd, 77.5 MHz square-wave, input signal to simulate any cross-talk present between the transmitter and receiver sections of the transceiver.
16. All conditions of Note 15 apply except that the measurement is made at the center of the symbol with no window time-width.
17. Systematic Jitter contributed by the receiver is defined as the combination of Duty Cycle Distortion and Data Dependent Jitter. Systematic Jitter is measured at 50% threshold using a 155.52 MBd (77.5 MHz square-wave), 2⁷ - 1 psuedo-random data pattern input signal.
18. Random Jitter contributed by the receiver is specified with a 155.52 MBd (77.5 MHz square-wave) input signal.
19. This value is measured during the transition from low to high levels of input optical power.
20. This value is measured during the transition from high to low levels of input optical power.
21. The Signal Detect output shall be asserted within 100 μs after a step increase of the Input Optical Power (130 μs for -40°C to 0°C).
22. Signal detect output shall be de-asserted within 350 μs after a step decrease in the Input Optical Power.
23. The AFBR-5205Z transceiver complies with the requirements for the tradeoffs between center wave-length, spectral width, and rise/fall times shown in Figure 9. This figure is derived from the FDDI PMD standard (ISO/IEC 9314-3 : 1990 and ANSI X3.166 - 1990) per the description in ANSI T1E1.2 Revision 3. The interpretation of this figure is that values of Center Wavelength and Spectral Width must lie along the appropriate Optical Rise/Fall Time curve.

Ordering Information

The following 1300 nm transceivers are available for production orders through the Agilent Component Field Sales Offices and Authorized Distributors world wide.

*For flush shield options, please contact Field Sales Offices and Authorized Distributors world wide.

1300nm LED, ATM/SONET OC-3, 155MBd temperature range 0°C to +70°C

AFBR-5205Z	DUPLEX SC Connector 1X9, 2KM
AFBR-5205TZ	Duplex ST Connector 1X9
AFBR-5205PZ	Duplex SC Connector 1x9, Mezzanine Height
AFBR-5205PEZ	Duplex SC Connector 1x9, Mezzanine Height with Extended Shield

1300nm LED, 155MBd temperature range -40°C to +85°C

AFBR-5205AZ	ATM/SONET OC-3 DUPLEX SC Connector 1X9
AFBR-5205ATZ	ATM/SONET OC-3 DUPLEX ST Connector 1X9

www.agilent.com/semiconductors

For product information and a complete list of distributors, please go to our web site.

For technical assistance call:

Americas/Canada: +1 (800) 235-0312 or
(916) 788-6763

Europe: +49 (0) 6441 92460

China: 10800 650 0017

Hong Kong: (+65) 6756 2394

India, Australia, New Zealand: (+65) 6755 1939

Japan: (+81 3) 3335-8152 (Domestic/International), or 0120-61-1280 (Domestic Only)

Korea: (+65) 6755 1989

Singapore, Malaysia, Vietnam, Thailand,
Philippines, Indonesia: (+65) 6755 2044

Taiwan: (+65) 6755 1843

Data subject to change.

Copyright © 2005 Agilent Technologies, Inc.

May 12, 2005

5989-2296EN



Agilent Technologies