

Temperature Compensated Crystal Oscillators (TCXO) Surface Mount Type TCXO (LSI Type) KT2520Y Series for GPS



2.5×2.0mm



Ph Free

RoHS Compliant

Features

- Ultra-miniature SMD type (2.5×2.0×0.9mm)
- Frequency stability : $\pm 0.5 \times 10^{-6} / -30$ to $+85^\circ\text{C}$
- 2.3 to 3.5V drive available
- Reflow compatible

Applications

- GPS Units

How to Order

KT2520Y 16369 A C W 28 T xx
① ② ③ ④ ⑤ ⑥ ⑦ ⑧

① Series	A	⑥ Supply Voltage	28 2.8V 30 3.0V
② Output Frequency	16369	⑦ Voltage Control Range	TCXO T
③ Frequency Tolerance	A	⑧ Option Code	
④ Lower Operating Temp.	C		
	E		
	G		
⑤ Upper Operating Temp.	W		
	V		
	U		

Specifications

Item	Symbol	Conditions	Min.	Max.	Units
Output Frequency Range	F _o	Standard Frequency: 16.369, 19.2, 24.5535, 26, 27.456			MHz
Frequency Tolerance	F _{tol}	vs Temperature	-0.5	+0.5	×10 ⁻⁶
		vs Load	-0.2	+0.2	
		vs Voltage	-0.3	+0.3	
Frequency Aging	F _{aging}	Per Year	-1	+1	×10 ⁻⁶
Storage Temperature Range	T _{sto}		-40	+85	°C
Operating Temperature Range	T _{use}		-30	+85	°C
Supply Voltage	V _{cc}		2.3	3.5	V
Output Level	V _{pp}	10k ohm // 10pF	0.8		Vp-p
Current Consumption	I _{cc}			2	mA
Symmetry	SYM	@50% V _{cc}	40	60	%
Harmonics	—			-5	dBc

Dimensions

(Unit: mm)

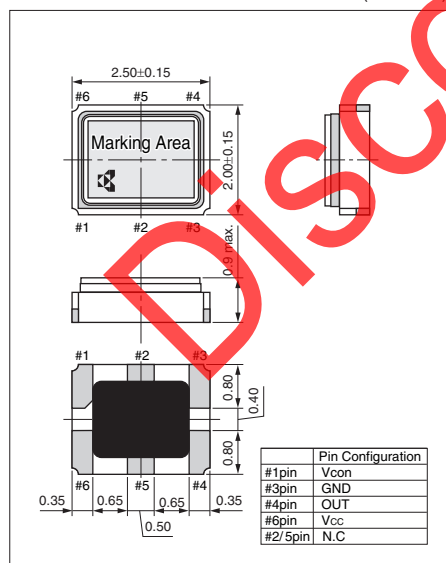

Test Circuit

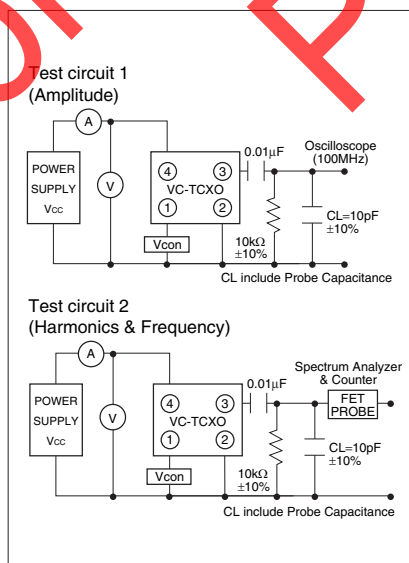

Recommended Land Pattern

(Unit: mm)

