



SMS IP: high voltage sealed plastic connector

A connector designed for indoor railway equipments, using the standard Ø 1.6 contact.

Safe ■ Finger proof
High operating voltage up to 500 V

Compliant to fire and smoke standards ■ CEN / TS 45-545
NF F 16-101/16-102

Sealed ■ IP66 & IP67

Easy to handle ■ 1 stainless steel latch

Designed for railways ■ NF F 61-030 derivated



The SOURIAU solution offers a wide range of connector layouts providing a simplified process from purchasing to harnessing: 1 type of contact to order, to manage, to stock, to crimp for a wide range of connectors. SOURIAU's standardisation policy is the best compromise between technology and cost.



SOURIAU connectors ensure the continuity of the network with railway qualified connectors integrating new technologies: copper contacts, Quadrax and fibre optics to transfer high speed Ethernet and other data protocols.



SOURIAU, along with its customers is committed to the research of energy efficiency and sustainability. The use of lightweight materials, fiber optics and high contact density contribute to the weight reduction of train equipments and help railway operators to save energy.

Technical features (NF F 61-030 derivated)



Mechanical

- **Durability:** 500 mating/unmating
- **Vibrations & shocks:** EN 61-373 Cat.2
- **Locking system:** 1 metallic latch - Audible "Click"
- **Keying system:** 3 different positions

Electrical

- **Current rating per contact:** 15 A maxi
- **Operating voltage:** ≤ 500 Vdc / ≤ 380 Vac following NF F 61-030
500 Vdc/ac following EN 50-124-1
- **Creepage distances (unmated):** > 12 mm
- **Clearance distances (unmated):** > 8 mm
- **Withstanding voltage:** 3250 V
- **Insulation resistance:** ≥ 5000 MΩ
- **Contacts resistance:** ≤ 2.5 mΩ

Material

- **Plug & receptacle:** black thermoplastic
- **Grommet & interfacial seal:** light grey silicone
- **Latch:** stainless steel

Environmental

- **Fire resistance, toxicity & smoke opacity:**
R23/HL3 following CEN/TS 45-545
I3/F2 2 following NF F 16-101/16-102
- **RoHS:** compliant
- **Damp heat:** 21 days / 40°C / 95% RH
- **Operating temperature:** -50°C to +100°C
- **Fluids:** NF F 61-030
- **Corrosion:** 500 hours salt spray

Sealed version (SMS IP67)

- **Sealing:** IP66 & IP67 - Following CEI 60-529
- Delivered with pre-mounted grommets and interfacial seal
- IP rating is ensured if the grommets are in their cavities.

Ordering information

SMS IP SERIES	SMS	3	P	IP67	-
Contact layout: 3 – 6 – 12					
Contact type: P: Plug for female contacts R: Receptacle for male contacts					
Application: IP67: Sealed version IP20: Non sealed version - delivered without grommet					
Contacts: -: Without contact K01: With contacts RM16M23K or RC16M23K K02: With contacts RM14M23K or RC14M23K					

Contacts

- Standard crimp machined contact #16 compatible with EN 50-306-2 & EN 50-264-3-1 wires

Contact size	Type	Wire size			Part number		Mini insulator Ø mm	Max insulator Ø mm
		AWG	mm2	Max wire Ø mm	Male	Female		
#16 Ø 1.6 mm	Machined	20-16	0.5-1.5	1.8	RM16M23K	RC16M23K	1.15	3.8
		16-14	1.5-2.5	2.28	RM14M30K	RC14M30K	1.15	3.8

For other contact type consult us

Dimensions & weight

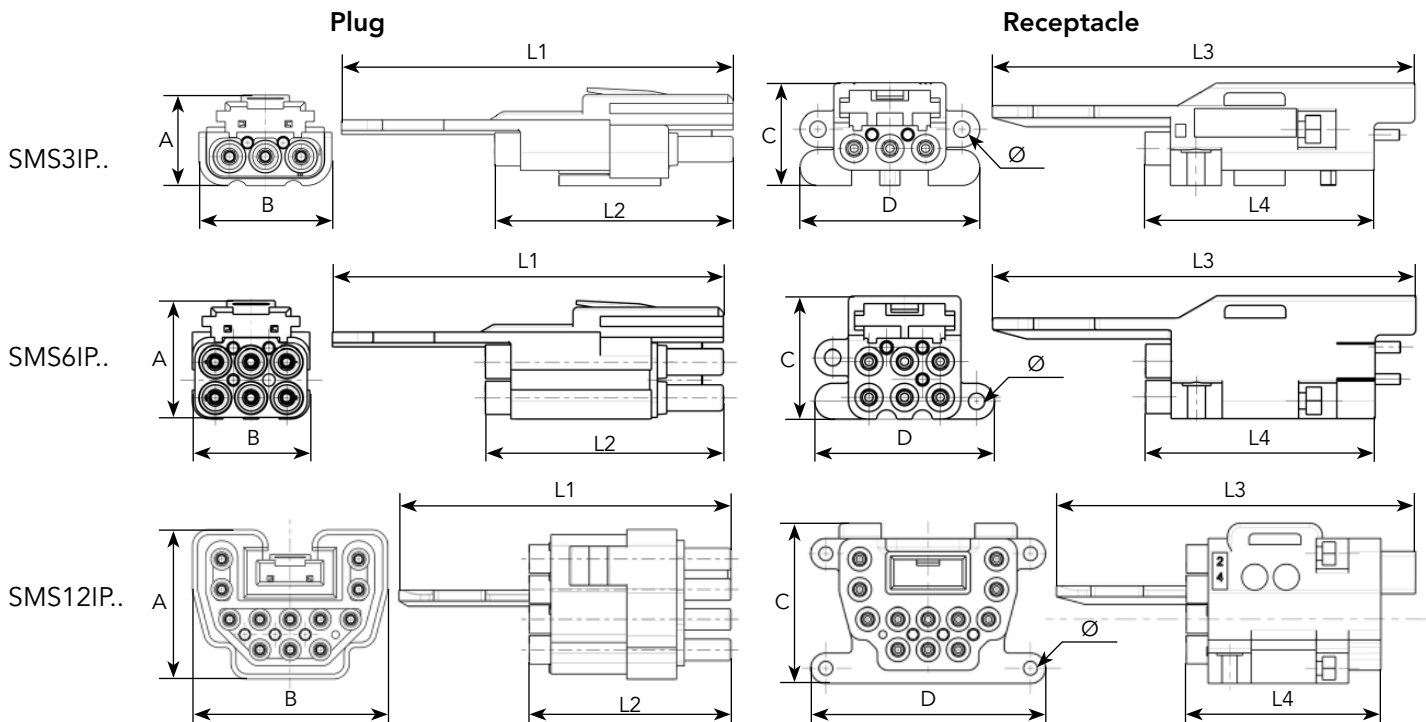

Part number		Layout	A	B	L1	L2	C	D	L3	L4	Ø	Weight *±0.2 g.	
Plug	Receptacle											IP20	IP66 & IP67
SMS3IP..	SMS3RIP..	3	18	26	77	42	-	-	-	-	-	13.3 g	16.1 g
SMS6IP..	SMS6RIP..	6	23	23	77	42	-	-	-	-	-	16.3 g	18.3 g
SMS12IP..	SMS12RIP..	12	35	46	77	42	-	-	-	-	-	40 g	45 g
							30	54	83	40	3.2	48 g	53 g

* weight of the connector without contact

Panel cut out

	A	B	C	D	E	F	Ø G
SMS3IP..	28.2	18.3	23.3	12.5	9.6	9.6	3.2
SMS6IP..	28.2	25.1	23.3	12.5	8.5	4	3.2
SMS12IP..	47.4	31.4	42.5	12.5	26.3	4	3.2

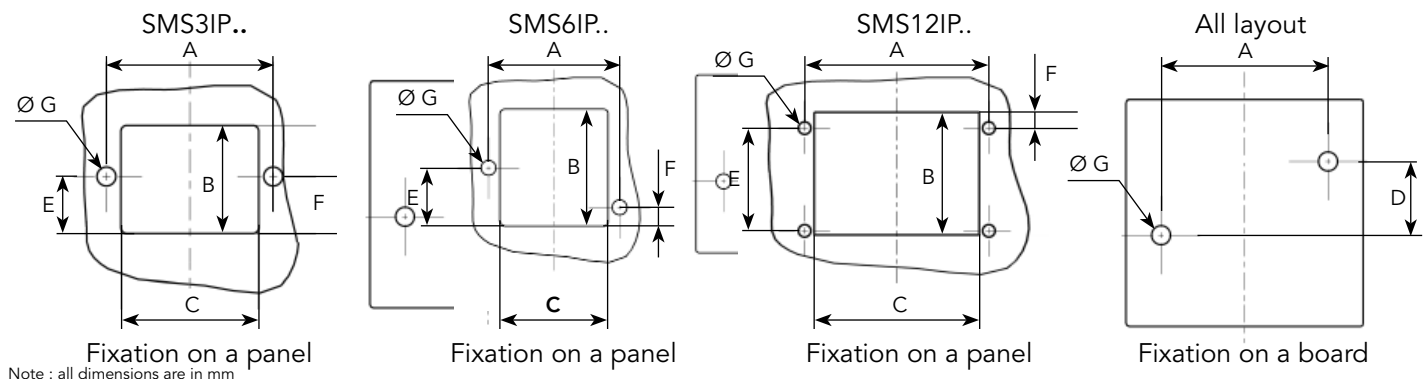

Assembly instructions

Crimp contacts on wires

- Strip each wire to the length indicated.



Crimping tools



Manual crimp pliers	Locator	Selector set-up - Wire section				
MH860 (M22520/7-01)	MH86164G or TP1142	6 0.5 mm ²	7 0.75 mm ²	7 1 mm ²	8 1.5 mm ²	-
FT8	-	4 0.5 mm ²	4 0.75 mm ²	5 1 mm ²	5 1.5 mm ²	-
AF8 (M22520/1-01)	TP1142	-	-	-	-	8 2.5 mm ²

Following standard: EN 50306-2

Following standard: EN 50264-3-1

Contact insertion

- Locate the right cavity and use a contact (male or female), to bore each individual grommet in its center. Push the contact until mechanical stop.



- Check the correct contact retention by slightly pulling on the cable (no tools required).
- Check that each individual grommet is correctly plated on the back face of the connector, unless, put them properly.

Once all the contacts have been installed in the connector:

- Put the ty-rap in the designated cable support and tighten the ty-rap to gather the wires.

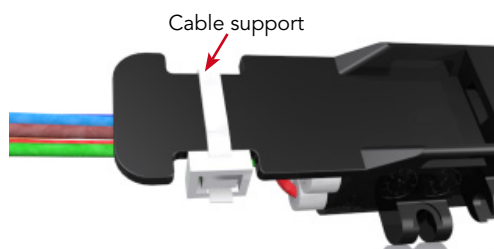

Receptacle coding

Connectors are supplied with coding pins, ensure to remove these pins before using the connectors.

- Coding is done by 1 or 2 pins depending on the layout (see page 7).

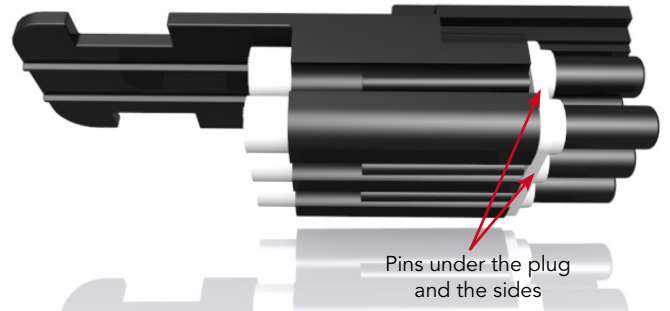
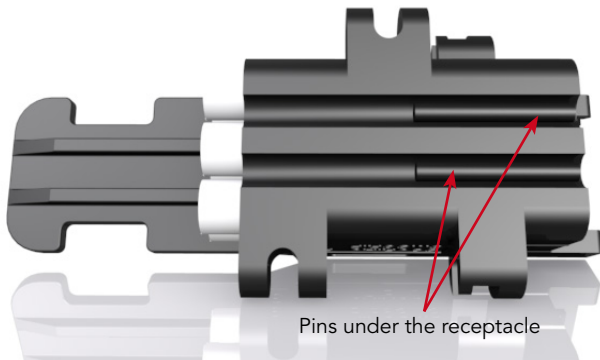

- Pre-locate the pin into the correct cavity depending on the chosen coding (see Coding configuration).

Receptacle

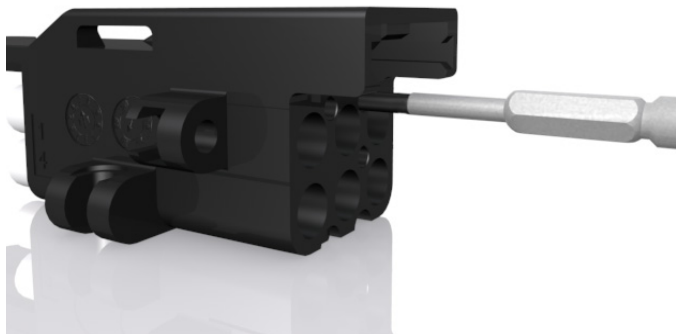

- Push the pin with the contact insertion tool (RX2025GE1) until mechanical stop. The outside height must be 5mm maxi.

Plug

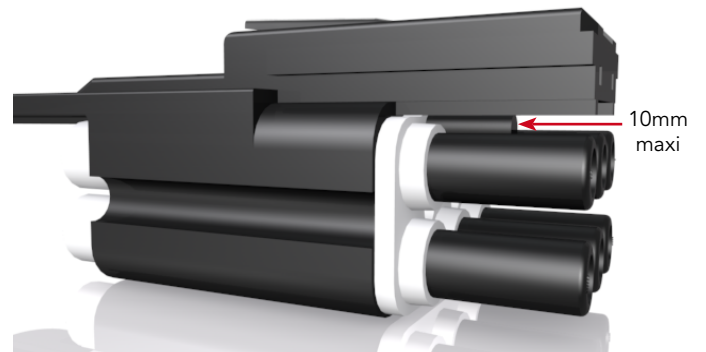
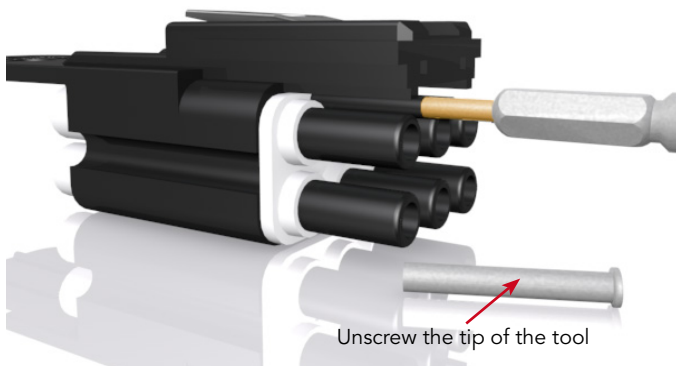

- Push the pin with the contact insertion tool (RX2025GE1) without its tip until mechanical stop. The outside height must be 10mm maxi.

Coding configuration

Layout 3

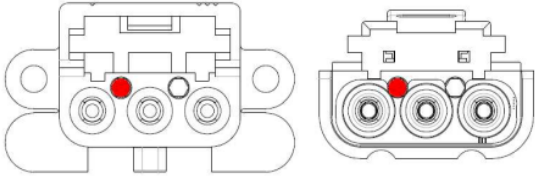

Coding A

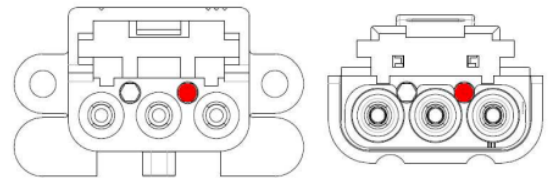

Coding B

Layout 6

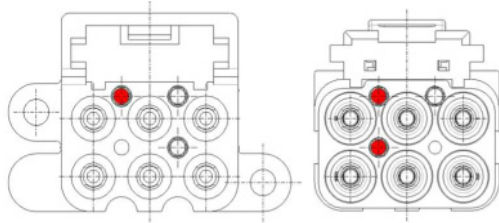

Coding A

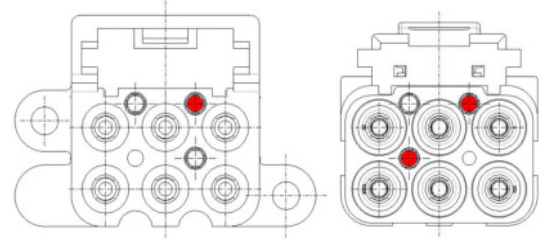

Coding B

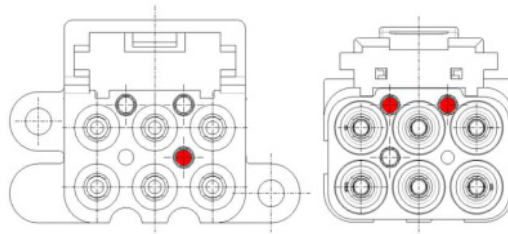

Coding C

Layout 12

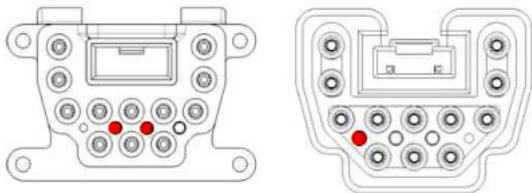

Coding A

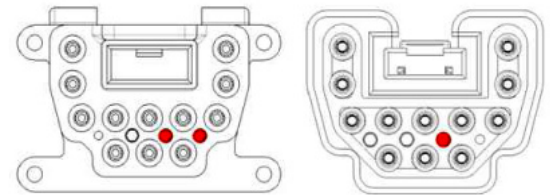

Coding B

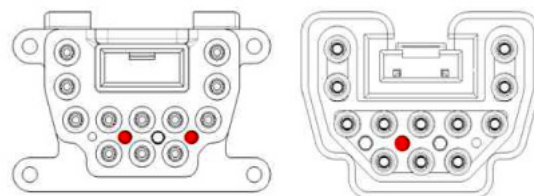

Coding C

Fixing the connectors

Rear panel mount fixing (Panel cut out dimensions page 4)

- Initially place the nut in its cavity. The nut must be placed correctly so that it cannot turn in its cavity.

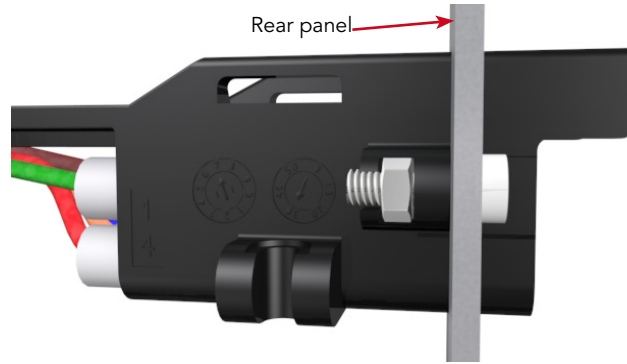

- Introduce the receptacle by the rear panel and tighten the 2 screws (washers can be added). The recommended tightening torque is: 1.7N.m maxi with M3 stainless steel screws.

Flat board receptacle fixing (Fixation points defined page 4)

- Place the receptacle on the flat board and tighten the 2 screws (washer can be added). The recommended tightening torque is: 1.7N.m maxi with M3 stainless steel.

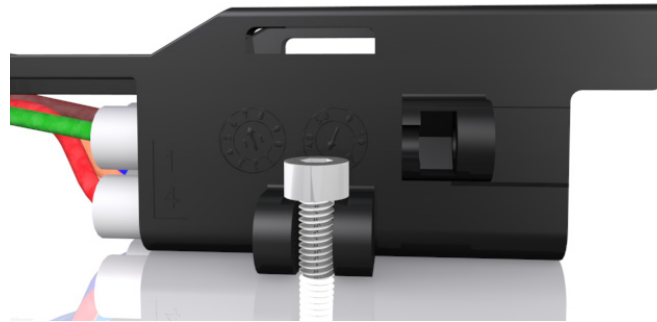

*For layout 6 cavities: In the particular case on using the connector at a working voltage higher than 220V along with a fixing on a conductive flat board, it will be necessary to insulate the board in order to meet the clearance and creepage distances given in the NFF61-030 standard.

Fixing by ty-rap

- Put the ty-rap through the 2 flat cable supports and tighten the receptacle against its panel (The locking system side should not be against the panel in order to keep the possibility to unmate the plug easily).

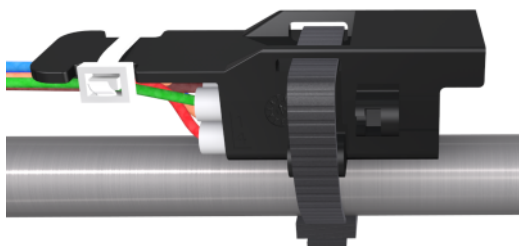

Mated pair

For further information, visit our website www.souriau-industrial.com or contact us at contactindustry@souriau.com