



## D571-Type Digital 1.5 $\mu\text{m}$ Uncooled DFB *FastLight*<sup>TM</sup> Laser Module



The low-profile D571-Type Laser Module is ideally suited for short- and long-haul SONET and other high-speed digital applications.

### Features

- Eight-pin package suitable for SONET applications
- Narrow linewidth, distributed-feedback, multi-quantum-well (DFB-MQW), 1510 nm or 1550 nm laser with single-mode fiber pigtail
- Wide operating temperature range:  
—40 °C to +85 °C
- No TEC required
- High output power:  
— Typical 2.0 mW peak power coupled into single-mode fiber  
— 1.0 mW devices are also available

- Hermetically sealed active components
- Internal back-facet monitor
- Qualification program: Bellcore TA-983

### Applications

- Long-reach SONET OC-3/OC-12 systems
- Telecommunications
- Secure digital data systems

### Benefits

- Easily board mounted
- Requires no lead bending
- No additional heat sinks required
- Pin compatible with industry-standard 14-pin laser module
- Highly efficient DFB-MQW laser structure allows for lower threshold and drive currents, and reduced power consumption

### Description

The D571-Type Uncooled Laser Module consists of a laser diode coupled to a single-mode fiber pigtail. The device is available in a standard, 8-pin configuration (see Figure 1 and/or Table 1) and is ideal for long-reach (SONET) and other high-speed digital applications.

The laser diode is a narrow linewidth (<1 nm) DFB-MQW single-mode laser and an InGaAs PIN photodiode back-facet monitor in an epoxy-free, hermetically sealed package.

**Description** (continued)

The device characteristics listed in this document are met at 2.0 mW output power. Higher- or lower-power operation is possible. Under conditions of a fixed photodiode current, the change in optical output is typically  $\pm 0.5$  dB over an operating temperature range of  $-40$   $^{\circ}\text{C}$  to  $+85$   $^{\circ}\text{C}$ .

This device incorporates the new Laser 2000 manufacturing process developed by the Optoelectronic unit of Lucent Technologies Microelectronics Group. Laser 2000 is a low-cost platform that targets high-volume manufacturing and tighter product distributions on all optical subassemblies. The platform incorporates an advanced optical design that is produced on a highly automated production line. The Laser 2000 platform is

qualified for the central office and uncontrolled environments, and can be used for applications requiring high performance and low cost.

**Table 1. Pin Descriptions**

| Pin Number | Connection          |
|------------|---------------------|
| 1          | NC/Reserved         |
| 2          | Case ground         |
| 3          | NC/Reserved         |
| 4          | Photodiode cathode  |
| 5          | Photodiode anode    |
| 6          | Laser diode cathode |
| 7          | Laser diode anode   |
| 8          | NC/Reserved         |

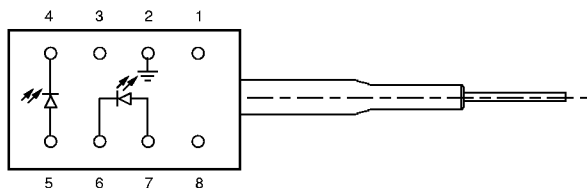

1-900 (C)

**Figure 1. D571-Type Digital Uncooled DFB FastLight Laser Module Schematic, Top View**

**Absolute Maximum Ratings**

Stresses in excess of the absolute maximum ratings can cause permanent damage to the device. These are absolute stress ratings only. Functional operation of the device is not implied at these or any other conditions in excess of those given in the operations sections of the data sheet. Exposure to absolute maximum ratings for extended periods can adversely affect device reliability.

| Parameter   | Symbol                | Min   | Max       | Unit                 |
|---|-----------------------|-------|-----------|----------------------|
| Maximum Peak Laser Drive Current or<br>Maximum Fiber Power* | $I_{OP}$<br>$P_{MAX}$ | —     | 150<br>10 | mA<br>mW             |
| Peak Reverse Laser Voltage:                                 |                       |       |           |                      |
| Laser   | $V_{RL}$              | —     | 2         | V                    |
| Monitor   | $V_{RM}$              | —     | 20        | V                    |
| Monitor Forward Current                                     | $I_{FD}$              | —     | 2         | mA                   |
| Operating Case Temperature Range                            | $T_C$                 | $-40$ | 85        | $^{\circ}\text{C}$   |
| Storage Case Temperature Range                              | $T_{stg}$             | $-40$ | 85        | $^{\circ}\text{C}$   |
| Lead Soldering Temperature/Time                             | —                     | —     | 260/10    | $^{\circ}\text{C/s}$ |
| Relative Humidity (noncondensing)                           | RH                    | —     | 85        | %                    |

\* Rating varies with temperature.

## Handling Precautions

**CAUTION: This device is susceptible to damage as a result of electrostatic discharge (ESD). Take proper precautions during both handling and testing. Follow guidelines such as JEDEC Publication No. 108-A (Dec. 1988).**

Although protection circuitry is designed into the device, take proper precautions to avoid exposure to ESD.

## Electro-Optical Characteristics

**Table 2. Electro-Optical Characteristics** (over operating temperature range unless otherwise noted)

| Parameter                          | Symbol          | Test Conditions  | Min       | Typ     | Max                   | Unit                         |
|------------------------------------|-----------------|--|-----------|---------|-----------------------|------------------------------|
| Operating Temperature Range        | T               | —  | -40       | —       | 85                    | $^{\circ}\text{C}$           |
| Optical Output Power*              | $P_F$           | CW, nominal  | —         | 2       | —                     | mW                           |
| Threshold Current                  | $I_{TH}$        | T = 25 $^{\circ}\text{C}$<br>T = full range  | 5<br>2    | 11<br>— | 15<br>60 <sup>†</sup> | mA<br>mA                     |
| Modulation Current                 | $I_{MOD}$       | CW, $P_F = 2.0$ mW, T = 25 $^{\circ}\text{C}$<br>CW, $I_{MON} = \text{constant}$ ,<br>T = full range | 15<br>7.5 | 25<br>— | 35<br>60 <sup>‡</sup> | mA<br>mA                     |
| Slope Efficiency <sup>§</sup>      | SE              | CW, $P_F = 2.0$ mW, T = 25 $^{\circ}\text{C}$  | 57        | —       | 133                   | $\mu\text{W}/\text{mA}$      |
| Center Wavelength**                | $\lambda_C$     | $P_F = 2.0$ mW, CW   | 1525      | 1550    | 1570                  | nm                           |
| Spectral Width (-20 dB)            | $\Delta\lambda$ | $P_F = 2.0$ mW, 622 Mbits/s  | —         | —       | 1                     | nm                           |
| Side-mode Suppression Ratio        | SMSR            | CW, $P_F = 2.0$ mW   | 30        | 40      | —                     | dB                           |
| Tracking Error                     | TE              | $I_{MON} = \text{constant}$ , CW   | —         | 0.5     | —                     | dB                           |
| Spontaneous Emission               | $P_{TH}$        | $I = (0.9) I_{TH}$   | —         | —       | 100                   | $\mu\text{W}$                |
| Rise/Fall Times                    | $t_R, t_F$      | 10%—90% pulse<br>T = 25 $^{\circ}\text{C}$   | —         | 0.25    | 0.5                   | ns                           |
| Forward Voltage                    | $V_F$           | CW   | —         | 1.1     | 1.6                   | V                            |
| Input Impedance                    | R               | —  | 3         | —       | 8                     | $\Omega$                     |
| Monitor Current                    | $I_{MON}$       | $V_R^{\dagger\dagger} = 5$ V   | 100       | —       | 1000                  | $\mu\text{A}$                |
| Monitor Dark Current               | $I_D$           | $V_R^{\dagger\dagger} = 5$ V   | —         | 10      | 200                   | nA                           |
| Wavelength Temperature Coefficient | —               | —  | —         | 0.09    | 0.12                  | $\text{nm}/^{\circ}\text{C}$ |

\* 1 mW power option also available. See Table 4 for more information.

<sup>†</sup>  $I_{TH\text{ MAX}} = 50$  mA for -20  $^{\circ}\text{C}$  to +70  $^{\circ}\text{C}$  codes.

<sup>‡</sup> BOL value; EOL = 80 mA.

<sup>§</sup> The slope efficiency is used to calculate the modulation current for a desired output power. This modulation current plus the threshold current comprise the total operating current for the device.

\*\* 1510 nm wavelength also available.

<sup>††</sup>  $V_R$  = reverse voltage.

**Outline Diagram**

Dimensions are in inches and (millimeters)

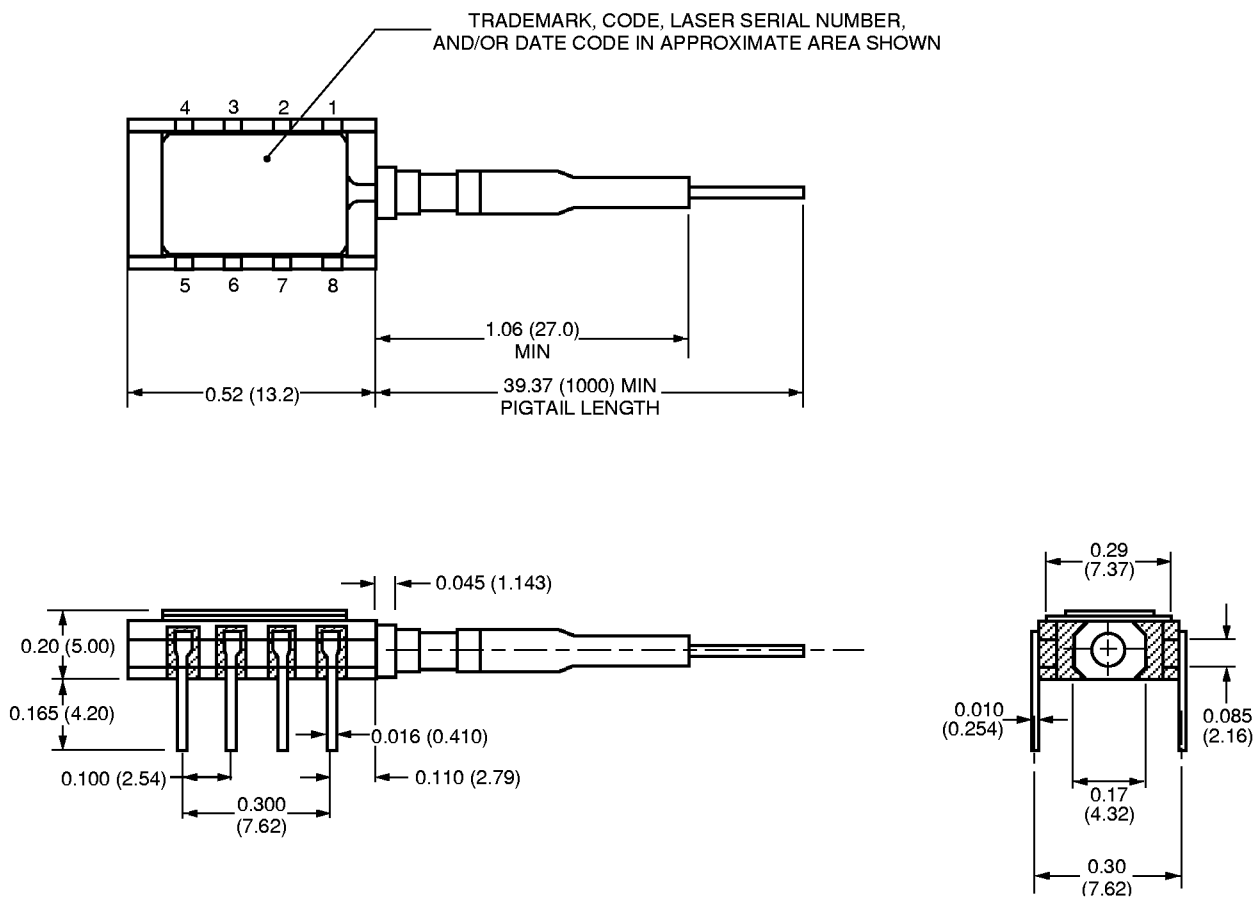

1-899.f

### Qualification Information

The D571-Type Laser Module is scheduled to complete the following qualification tests and meets the intent of Bellcore TR-NWT-000468 for interoffice environments and TA-TSY-000983 for outside plant environments.

**Table 3. D571-Type Laser Module Qualification Test Plan**

| <b>Qualification Test</b>  | <b>Conditions</b>  | <b>Sample Size</b> | <b>Reference</b>             |
|----------------------------|--|--------------------|------------------------------|
| Mechanical Shock           | 500 G for P/F<br>1,500 G for information   | 11                 | MIL-STD-883<br>Method 2002   |
| Vibration                  | 20 g, 20 Hz—2,000 Hz   | 11                 | MIL-STD-883<br>Method 2007   |
| Solderability              | —  | 11                 | MIL-STD-883<br>Method 2007   |
| Thermal Shock              | Delta T = 100 °C   | 11                 | MIL-STD-883<br>Method 2003   |
| Fiber Pull                 | 1 kg; 3 times for P/F<br>2 kg; 3 times for information                               | 11                 | Bellcore 983                 |
| Accelerated (Biased) Aging | 85 °C, 5,000 hrs.  | 25                 | Bellcore 983<br>Section 5.18 |
| 85 °C Storage              | 1,000 hrs. for provisional qual.<br>2,000 hrs. for P/F<br>5,000 hrs. for information | 11                 | Bellcore 983                 |
| Temperature Cycling        | 500 cycles for P/F<br>1,000 cycles for information                                   | 11                 | Bellcore 983<br>Section 5.20 |
| Cyclic Moisture Resistance | 10 cycles for P/F<br>20 cycles for information                                       | 11                 | Bellcore 983<br>Section 5.23 |
| Damp Heat                  | 40 °C, 95% RH<br>1,000 hrs. for provisional qual.<br>1,344 hrs. for P/F              | 11                 | MIL-STD-202<br>Method 103    |
| Internal Moisture          | <5,000 ppm water vapor   | 11                 | MIL-STD-883<br>Method 1018   |
| Flammability               | —  | —                  | TR357<br>Sec. 4.4.2.5        |
| ESD Threshold              | —  | 6                  | Bellcore 983<br>Section 5.22 |

## Laser Safety Information

### Class IIIb Laser Product

This product complies with 21 CFR 1040.10 and 1040.11.

8.3  $\mu\text{m}$  single-mode pigtail or connector

Wavelength = 1.5  $\mu\text{m}$

Maximum power = 10 mW

Because of size constraints, laser safety labeling is not affixed to the module but attached to the outside of the shipping carton.

Product is not shipped with power supply.

**Caution: Use of controls, adjustments, and procedures other than those specified herein may result in hazardous laser radiation exposure.**

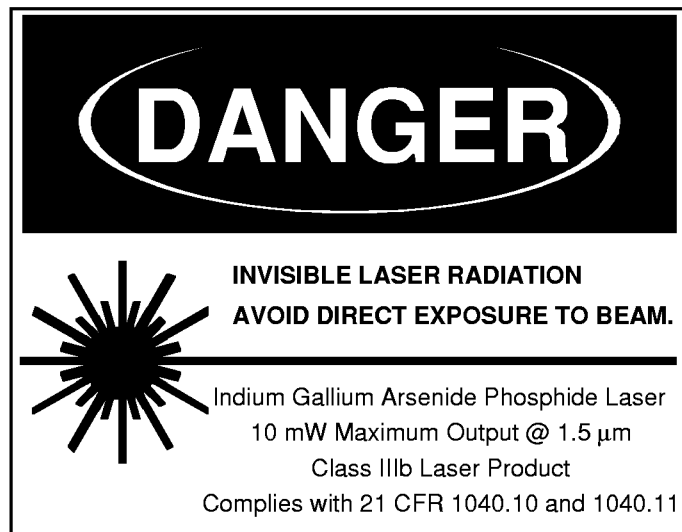

**DANGER: Invisible laser radiation is emitted from  
the end of the fiber or connector.  
AVOID DIRECT EXPOSURE TO BEAM.  
Do not view with optical instruments.**

## Ordering Information

Table 4. Ordering Information

| Device Code | Comcode   | Pfiber | Wavelength | Connector | Operating Case Temperature Range ( $^{\circ}\text{C}$ ) |
|-------------|-----------|--------|------------|-----------|---|
| D571-10A    | 108401118 | 1.0 mW | 1550 nm    | SC-PC     | -40 to +85  |
| D571-10B    | 108401126 | 1.0 mW | 1550 nm    | SC-APC    | -40 to +85  |
| D571-10F    | 108401068 | 1.0 mW | 1550 nm    | FC-PC     | -40 to +85  |
| D571-10G    | 108401134 | 1.0 mW | 1550 nm    | FC-APC    | -40 to +85  |
| D571-10N    | 108401142 | 1.0 mW | 1550 nm    | none      | -40 to +85  |
|             |           |        |            |           |   |
| D571-11A    | 108401159 | 1.0 mW | 1550 nm    | SC-PC     | -20 to +70  |
| D571-11B    | 108401167 | 1.0 mW | 1550 nm    | SC-APC    | -20 to +70  |
| D571-11F    | 108401175 | 1.0 mW | 1550 nm    | FC-PC     | -20 to +70  |
| D571-11G    | 108401183 | 1.0 mW | 1550 nm    | FC-APC    | -20 to +70  |
| D571-11N    | 108401191 | 1.0 mW | 1550 nm    | none      | -20 to +70  |
|             |           |        |            |           |   |
| D571-20A    | 108217068 | 2.0 mW | 1550 nm    | SC-PC     | -40 to +85  |
| D571-20B    | 108401209 | 2.0 mW | 1550 nm    | SC-APC    | -40 to +85  |
| D571-20F    | 108401217 | 2.0 mW | 1550 nm    | FC-PC     | -40 to +85  |
| D571-20G    | 108401225 | 2.0 mW | 1550 nm    | FC-APC    | -40 to +85  |
| D571-20N    | 108401233 | 2.0 mW | 1550 nm    | none      | -40 to +85  |
|             |           |        |            |           |   |
| D571-21A    | 108401241 | 2.0 mW | 1550 nm    | SC-PC     | -20 to +70  |
| D571-21B    | 108401258 | 2.0 mW | 1550 nm    | SC-APC    | -20 to +70  |
| D571-21F    | 108401266 | 2.0 mW | 1550 nm    | SC-PC     | -20 to +70  |
| D571-21G    | 108401274 | 2.0 mW | 1550 nm    | FC-APC    | -20 to +70  |
| D571-21N    | 108401282 | 2.0 mW | 1550 nm    | none      | -20 to +70  |
|             |           |        |            |           |   |
| D571-50A    | —         | 2.0 mW | 1510 nm    | SC-PC     | -40 to +85  |
| D571-50F    | —         | 2.0 mW | 1510 nm    | FC-PC     | -40 to +85  |
| D571-52A    | —         | 2.0 mW | 1510 nm    | SC-PC     | -20 to +70  |
| D571-52F    | —         | 2.0 mW | 1510 nm    | FC-PC     | -20 to +70  |

---

For additional information, contact your Microelectronics Group Account Manager or the following:

INTERNET: <http://www.lucent.com/micro>, or for Optoelectronics information, <http://www.lucent.com/micro/opto>

E-MAIL: [docmaster@micro.lucent.com](mailto:docmaster@micro.lucent.com)

N. AMERICA: Microelectronics Group, Lucent Technologies Inc., 555 Union Boulevard, Room 30L-15P-BA, Allentown, PA 18103  
**1-800-372-2447**, FAX 610-712-4106 (In CANADA: **1-800-553-2448**, FAX 610-712-4106)

ASIA PACIFIC: Microelectronics Group, Lucent Technologies Singapore Pte. Ltd., 77 Science Park Drive, #03-18 Cintech III, Singapore 118256  
**Tel. (65) 778 8833**, FAX (65) 777 7495

CHINA: Microelectronics Group, Lucent Technologies (China) Co., Ltd., A-F2, 23/F, Zao Fong Universe Building, 1800 Zhong Shan Xi Road, Shanghai 200233 P. R. China **Tel. (86) 21 6440 0468, ext. 316**, FAX (86) 21 6440 0652

JAPAN: Microelectronics Group, Lucent Technologies Japan Ltd., 7-18, Higashi-Gotanda 2-chome, Shinagawa-ku, Tokyo 141, Japan  
**Tel. (81) 3 5421 1600**, FAX (81) 3 5421 1700

EUROPE: Data Requests: MICROELECTRONICS GROUP DATALINE: **Tel. (44) 1189 324 299**, FAX (44) 1189 328 148  
Technical Inquiries: OPTOELECTRONICS MARKETING: **(44) 1344 865 900** (Ascot UK)

---

Lucent Technologies Inc. reserves the right to make changes to the product(s) or information contained herein without notice. No liability is assumed as a result of their use or application. No rights under any patent accompany the sale of any such product(s) or information. *FastLight* is a trademark of Lucent Technologies Inc.

Copyright © 1999 Lucent Technologies Inc.  
All Rights Reserved

January 1999  
DS99-056LWP

microelectronics group

Lucent Technologies  
Bell Labs Innovations

