

Features

- Saturated Output Power: 31 dBm Typical
- High Linear Gain: 32 dB Typical
- High Power Added Efficiency: 30 % at P_{SAT}
- 50 Ω Input / Output Match
- Lead-Free 6 mm 28-lead PQFN Package
- 100% Matte Tin Plating over Copper
- Halogen-Free "Green" Mold Compound
- RoHS* Compliant and 260°C Reflow Compatible

Description

The MAAPSS0111 is a four stage MMIC power amplifier designed specifically for Ku-Band VSAT applications. It can be used as either a driver or an output stage amplifier. The MAAPSS0111 is fully matched input and output to 50 ohms which eliminates any sensitive external RF tuning components. The device is packaged in a lead free 6 mm 28-lead PQFN leadless package for high volume manufacturing.

The MAAPSS0111 is fabricated using a high reliability self-aligned gate MESFET process, MSAG, to realize good power added efficiency and gain. The MSAG process features full passivation for high performance and reliability.

Ordering Information ^{1,2}

Part Number	Package
MAAPSS0111	Bulk Packaging
MAAPSS0111TR-3000	3000 piece reel
MAAPSS0111SMB	Sample Board

1. Reference Application Note M513 for reel size information.
2. All sample boards include 5 loose parts.

Functional Schematic

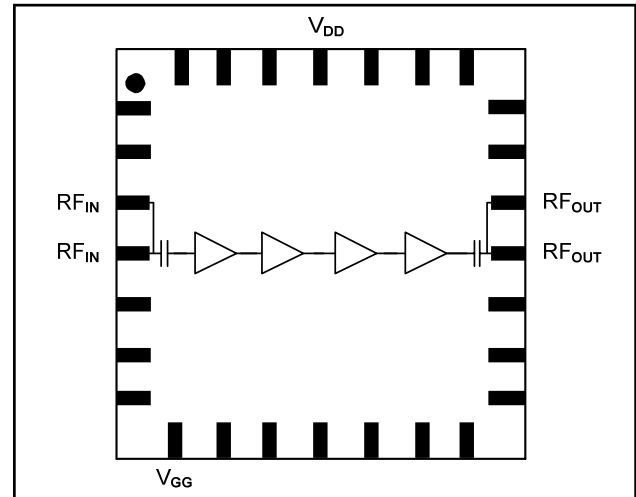

Pin Configuration

DC Pin	Function	DC Pin	Function
1	No Connection	15	No Connection
2	No Connection	16	No Connection
3	RF _{IN}	17	No Connection
4	RF _{IN}	18	RF _{OUT}
5	No Connection	19	RF _{OUT}
6	No Connection	20	No Connection
7	No Connection	21	No Connection
8	V _{GG}	22	No Connection
9	No Connection	23	No Connection
10	No Connection	24	No Connection
11	No Connection	25	V _{DD}
12	No Connection	26	No Connection
13	No Connection	27	No Connection
14	No Connection	28	No Connection
		29	Paddle ³

3. The exposed pad centered on the package bottom must be connected to RF and DC ground.

* Restrictions on Hazardous Substances, European Union Directive 2002/95/EC.

Electrical Specifications: F = 14.25 GHz, V_{DD} = 8 V, I_{DQ} = 450 mA, T_A = 25 °C, Z₀ = 50 Ω

Parameter	Test Conditions	Units	Min.	Typ.	Max.
Gain	—	dB	28	32	36
Gain Flatness	13.75 - 14.5 GHz	dB	—	1	—
Input Return Loss	—	dB	—	14	—
Output Return Loss	—	dB	—	12	—
P _{SAT}	P _{IN} = +4 dBm	dBm	29	31	—
Current	I _{DQ} P _{SAT}	mA mA	— —	450 530	— 600
PAE	P _{SAT}	%	—	30	—
IM3	P _{OUT} / Tone = +24 dBm	dBc	—	26	—
Gate Bias	Voltage Current under saturation	V mA	—	-1.9 0.2	—
Duty Cycle	—	%	—	—	100
Thermal Resistance	Junction to case (case = back of package)	°C/W	—	19	—
Stability	+2.5V < V _{CC} < +8.0 V, P _{OUT} = saturated, VSWR < 5:1, -40°C < T _C < +85 °C, RBW = 3 MHz max hold		All spurs < -60 dBc		

Operating the MAAPSS0111

The MAAPSS0111 is static sensitive. Please handle with care. To operate the device, follow these steps. Ramp down or shutdown in reverse order (gate bias on first and off last).

1. Apply V_{GG} (-2.0 V).
2. Apply V_{DD} (8.0 V Typical).
3. Set I_{DQ} by adjusting V_{GG}.
4. Apply RF_{IN}.

Handling Procedures

Please observe the following precautions to avoid damage:

Static Sensitivity

Gallium Arsenide Integrated Circuits are sensitive to electrostatic discharge (ESD) and can be damaged by static electricity. Proper ESD control techniques should be used when handling these devices.

Absolute Maximum Ratings ^{4,5}

Parameter	Absolute Maximum
Input Power	+10 dBm
Operating Supply Voltage	+10 Volts
Operating Gate Voltage	-3 Volts
Operating Base Temperature	-40°C to +85°C
Channel Temperature	+160 °C
Storage Temperature	-40°C to +150°C

4. Exceeding any one or combination of these limits may cause permanent damage to this device.
5. M/A-COM does not recommend sustained operation near these survivability limits.

Evaluation Test Board

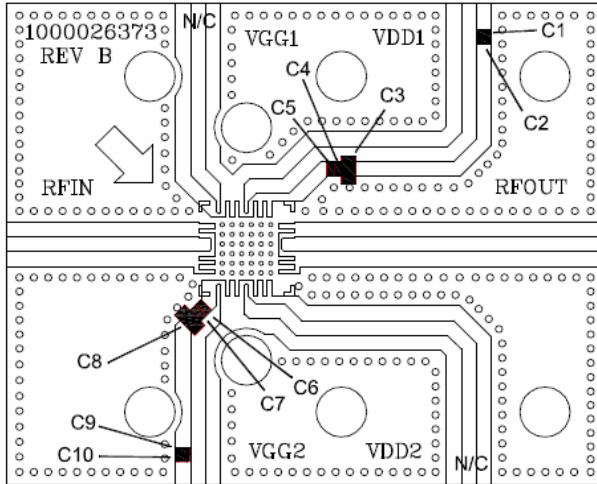

Cross Section View

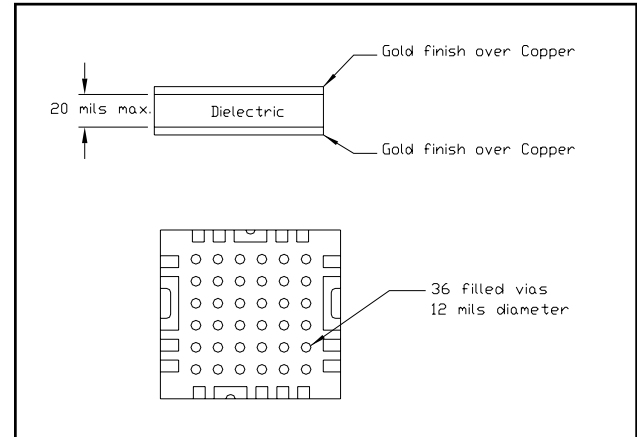

External Parts List

Designator	Value	Foot Print
C1, C10	1 μ F	0402
C2, C9	10 pF	0402
C3, C8	10 μ F	0804
C4, C7	0.1 μ F	0402
C5, C6	100 pF	0402

Notes on board design:

1. A low loss dielectric material such as Rogers 4003, $\epsilon_r = 3.38$, is recommended for this application.
2. A substrate thickness of 20 mils (0.508 mm) maximum is recommended to minimize thermal resistance and ground impedances.
3. RF transmission line impedance must be 50 ohms ($w = 42$ mils (1.0668 mm) for $t = 20$ mils (0.508 mm), Rogers 4003).
4. The board must provide low thermal resistance from package base to heat sink to accommodate the 3 W typical power dissipation.
5. Metal foil thickness in the vias is critical to thermal resistance. The recommended metalization is 1 oz (35 μ m minimum thickness).
6. The application board is configured with 36 vias, each 12 mil (0.3048 mm) in diameter beneath the package base. Conductive via fill material is recommended to minimize thermal resistance and to prevent solder from wicking into vias.
7. The exposed package pad must be properly soldered to the board.
8. Case temperature is measured at the interface between the package bottom and circuit board.

1.25 W VSAT Power Amplifier
13.75 - 14.5 GHz

M/A-COM Products
Rev. V1

Performance Curves: $V_{DD} = 8\text{ V}$, $I_{DQ} = 450\text{ mA}$, $T_A = 25\text{ }^\circ\text{C}$, $Z_0 = 50\text{ }\Omega$

Input Return Loss

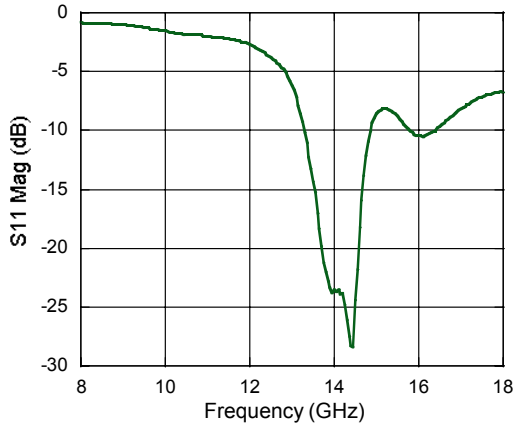

Input Return Loss, 12 - 16 GHz

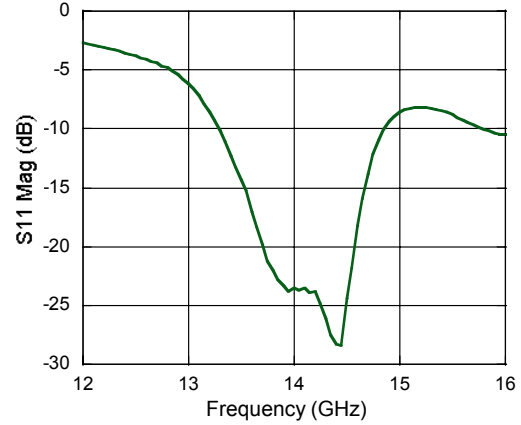

Output Return Loss

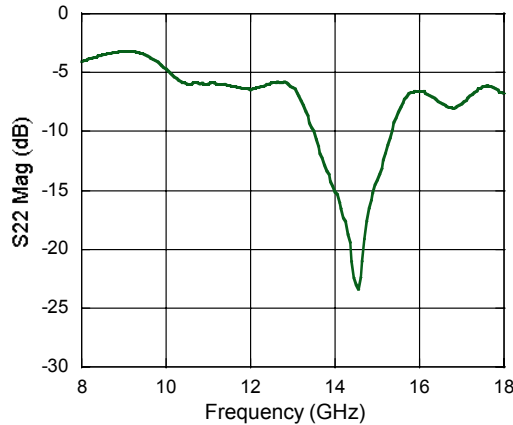

Output Return Loss, 12 - 16 GHz

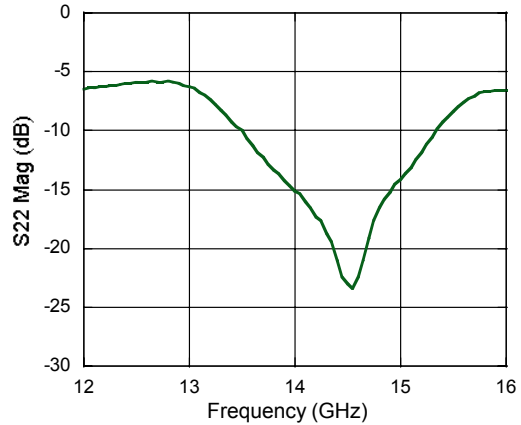

Gain

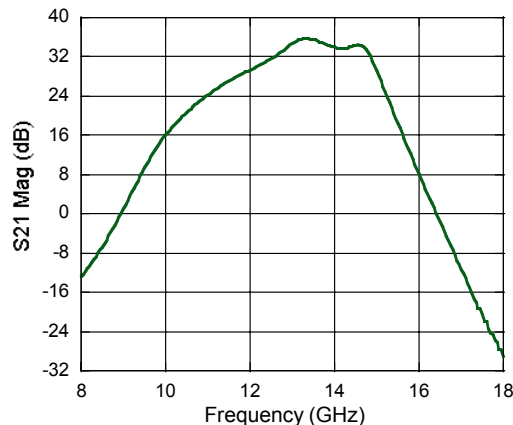

Gain, 12 - 16 GHz

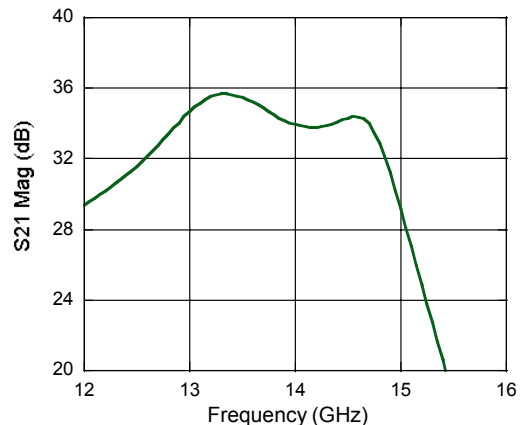

ADVANCED: Data Sheets contain information regarding a product M/A-COM is considering for development. Performance is based on target specifications, simulated results, and/or prototype measurements. Commitment to develop is not guaranteed.

PRELIMINARY: Data Sheets contain information regarding a product M/A-COM has under development. Performance is based on engineering tests. Specifications are typical. Mechanical outline has been fixed. Engineering samples and/or test data may be available. Commitment to produce in volume is not guaranteed.

- **North America** Tel: 800.366.2266 / Fax: 978.366.2266
- **Europe** Tel: 44.1908.574.200 / Fax: 44.1908.574.300
- **Asia/Pacific** Tel: 81.44.844.8296 / Fax: 81.44.844.8298

Visit www.macom.com for additional data sheets and product information.

M/A-COM Inc. and its affiliates reserve the right to make changes to the product(s) or information contained herein without notice.

1.25 W VSAT Power Amplifier 13.75 - 14.5 GHz

M/A-COM Products
Rev. V1

Typical Performance Curves: $V_{DD} = 8\text{ V}$, $I_{DQ} = 450\text{ mA}$, $T_A = 25\text{ }^\circ\text{C}$, $Z_0 = 50\text{ }\Omega$

P_{OUT} , Gain, PAE vs. P_{IN} @ 14.25 GHz

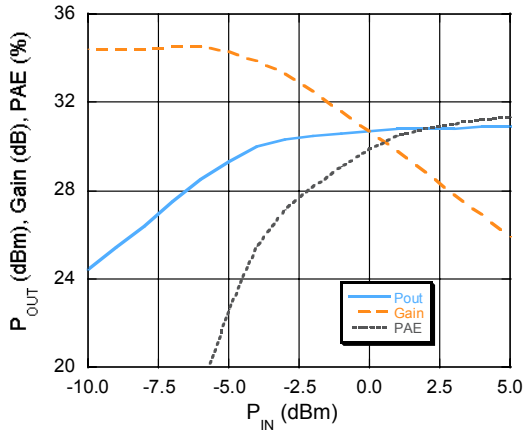

P_{SAT} vs. Frequency, $P_{IN} = 4\text{ dBm}$

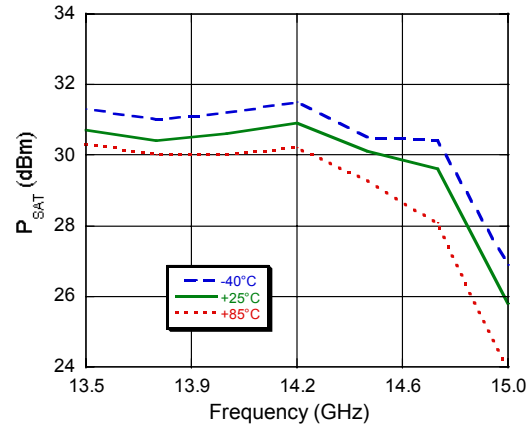

Gate Current vs. P_{OUT}

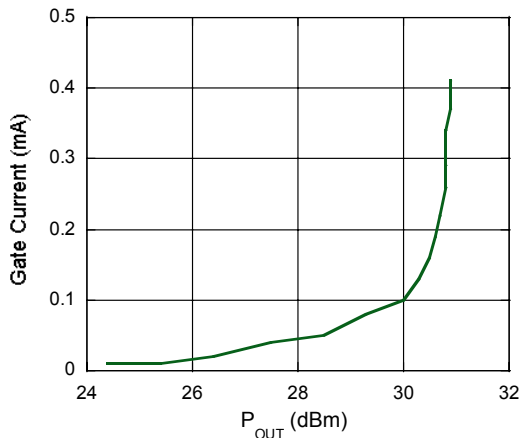

IM3 vs. P_{OUT} /Tone @ 14 GHz, $I_{DQ} = 450\text{ mA}$

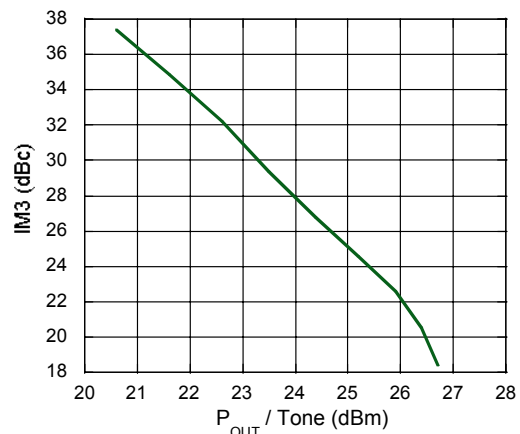

P_{DISS} , I_{DD} vs. P_{out} @ 14.25 GHz

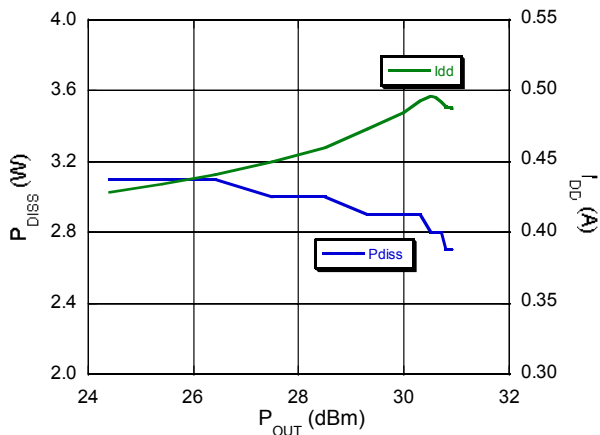

P_{DISS} vs. Max. Case Temperature

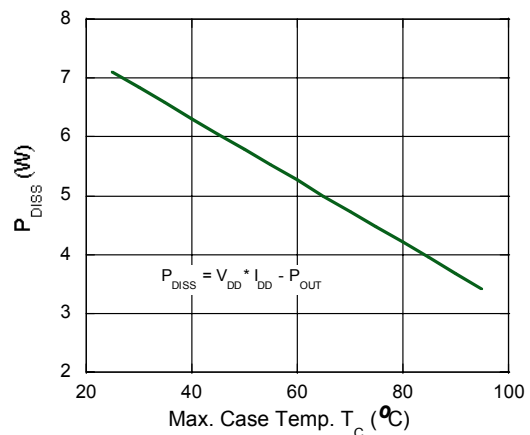

ADVANCED: Data Sheets contain information regarding a product M/A-COM is considering for development. Performance is based on target specifications, simulated results, and/or prototype measurements. Commitment to develop is not guaranteed.

PRELIMINARY: Data Sheets contain information regarding a product M/A-COM has under development. Performance is based on engineering tests. Specifications are typical. Mechanical outline has been fixed. Engineering samples and/or test data may be available. Commitment to produce in volume is not guaranteed.

- **North America** Tel: 800.366.2266 / Fax: 978.366.2266
- **Europe** Tel: 44.1908.574.200 / Fax: 44.1908.574.300
- **Asia/Pacific** Tel: 81.44.844.8296 / Fax: 81.44.844.8298

Visit www.macom.com for additional data sheets and product information.

M/A-COM Inc. and its affiliates reserve the right to make changes to the product(s) or information contained herein without notice.

Typical Performance Curves: $T_A = 25\text{ }^\circ\text{C}$, $Z_0 = 50\text{ }\Omega$

Gain vs. P_{OUT} @ 14 GHz, $P_{IN} = -10\text{ dBm}$
 $V_{DD} = 8\text{ V}$, $I_{CQ} = 450\text{ mA}$ & $V_{DD} = 9\text{ V}$, $I_{CQ} = 400\text{ mA}$

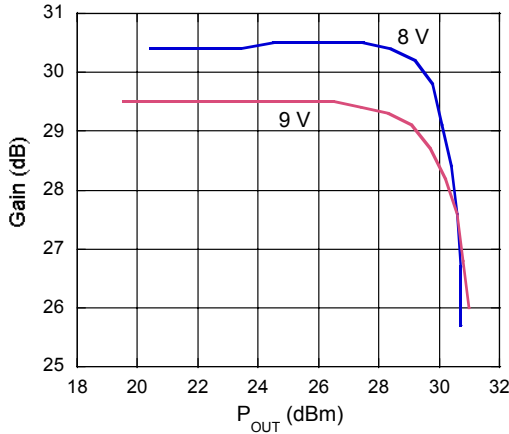

P_{OUT} vs. Frequency @ $P_{IN} = -10\text{ dBm}$
 $V_{DD} = 8\text{ V}$, $I_{CQ} = 450\text{ mA}$ & $V_{DD} = 9\text{ V}$, $I_{CQ} = 400\text{ mA}$

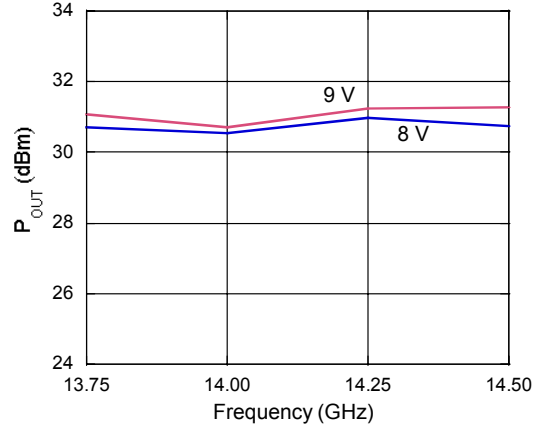

Lead-Free 6 mm 28-Lead PQFN[†]

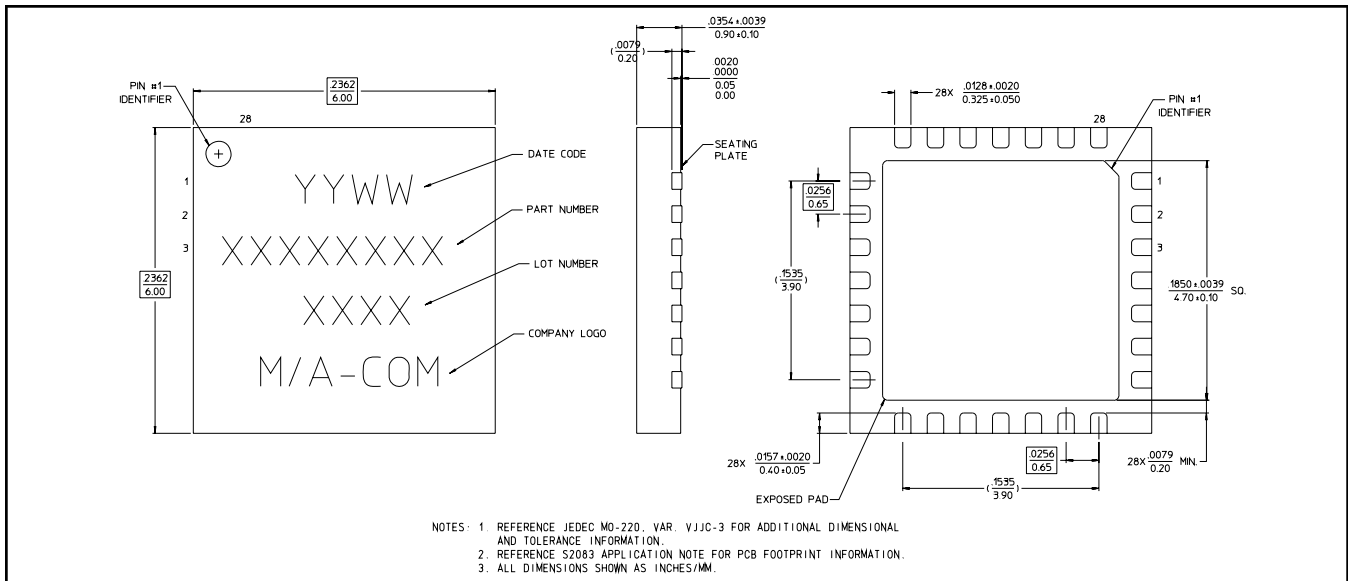

[†] Reference Application Note M538 for lead-free solder reflow recommendations.
Meets JEDEC moisture sensitivity level 1 requirements.

ADVANCED: Data Sheets contain information regarding a product M/A-COM is considering for development. Performance is based on target specifications, simulated results, and/or prototype measurements. Commitment to develop is not guaranteed.

PRELIMINARY: Data Sheets contain information regarding a product M/A-COM has under development. Performance is based on engineering tests. Specifications are typical. Mechanical outline has been fixed. Engineering samples and/or test data may be available. Commitment to produce in volume is not guaranteed.

- **North America** Tel: 800.366.2266 / Fax: 978.366.2266
- **Europe** Tel: 44.1908.574.200 / Fax: 44.1908.574.300
- **Asia/Pacific** Tel: 81.44.844.8296 / Fax: 81.44.844.8298

Visit www.macom.com for additional data sheets and product information.

M/A-COM Inc. and its affiliates reserve the right to make changes to the product(s) or information contained herein without notice.