

Advance Information

GaAs Power Amplifier Support IC

The MC33169 is a support IC for GaAs Power Amplifier Enhanced FETs used in hand portable telephones such as GSM, PCN and DECT. This device provides negative voltages for full depletion of Enhanced MESFETs as well as a priority management system of drain switching, ensuring that the negative voltage is always present before turning "on" the Power Amplifier. Additional features include an idle mode input and a direct drive of the N-Channel drain switch transistor.

This product is available in two versions, -2.5 and -4.0 V. The -4.0 V version is intended for supplying RF modules for GSM and DCS1800 applications, whereas the -2.5 V version is dedicated for DECT and PHS systems.

- Negative Regulated Output for Full Depletion of GaAs MESFETs
- Drain Switch Priority Management Circuit
- CMOS Compatible Inputs
- Idle Mode Input (Standby Mode) for Very Low Current Consumption
- Output Signal Directly Drives N-Channel FET
- Low Startup and Operating Current

MC33169

GaAs POWER AMPLIFIER SUPPORT IC

SEMICONDUCTOR TECHNICAL DATA

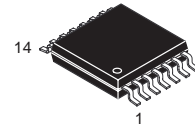

DTB SUFFIX
PLASTIC PACKAGE
CASE 948G
(TSSOP-14)

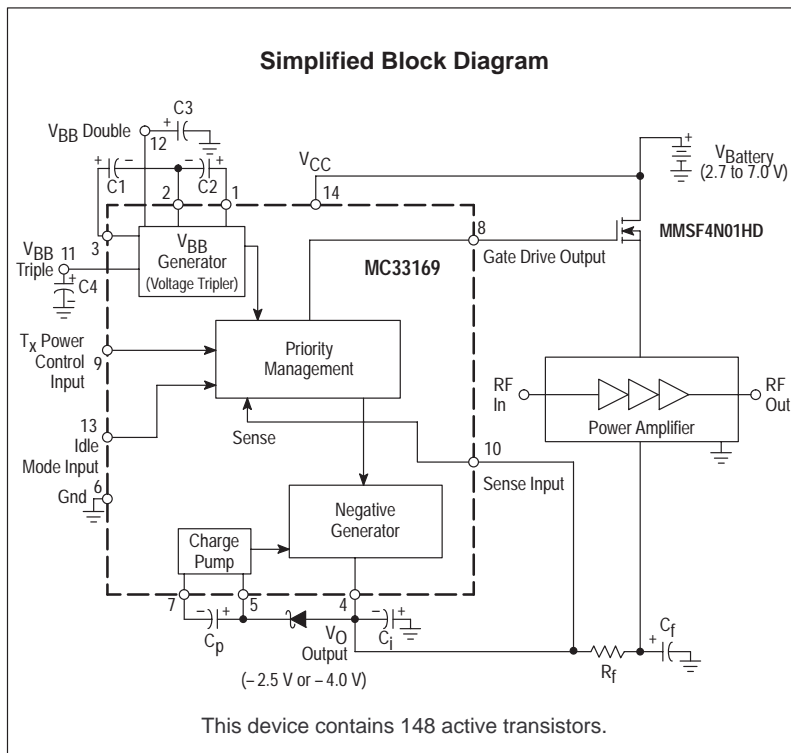

PIN CONNECTIONS

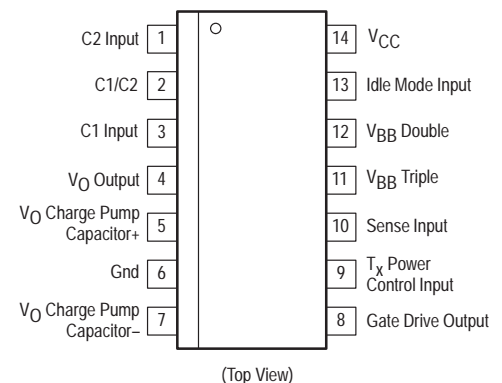

ORDERING INFORMATION

Device	Operating Temperature Range	Package
MC33169DTB-4.0	$T_A = -40^\circ$ to $+85^\circ\text{C}$	TSSOP-14
MC33169DTB-2.5		

MC33169

MAXIMUM RATINGS

Rating	Pin	Symbol	Value	Unit
Power Supply Voltage	14	V _{CC}	9.5	V
T _x Power Control Input	9	VT _x	V _{CC}	V
Idle Mode Input	13	V _i	V _{CC}	V
Sense Input	10	V _{Sense}	-5.0 to 0	V
Negative Generator Output Source Current	4	I _{SS}	20	mA
Charge Pump Capacitor Current	-	I _{max}	60	mA
Diode Forward Current	-	I _{Fmax}	60	mA
Gate Drive Output Current	8	I _{GO}	5.0	mA
Power Dissipation and Thermal Characteristics	-			
Maximum Power Dissipation @ T _A = 50°C		P _D	417	mW
Thermal Resistance, Junction-to-Air		R _{θJA}	240	°C/W
Operating Junction Temperature		T _J	+150	°C
Operating Ambient Temperature	-	T _A	-40 to +85	°C
Storage Temperature Range	-	T _{stg}	-60 to +150	°C

NOTE: ESD data available upon request.

MC33169-4.0

ELECTRICAL CHARACTERISTICS (V_{CC} = 4.8 V. For typical values T_A = 25°C, for min/max values T_A is the operating ambient temperature range that applies, unless otherwise noted.)

Characteristic	Pin	Symbol	Min	Typ	Max	Unit	
V_{BB} GENERATOR (VOLTAGE TRIPLER)							
Oscillator Frequency	-	f _{osc}	90	100	110	kHz	
Oscillator Duty Cycle	-	DC	35	50	65	%	
Output Voltage (V _{CC} = 3.0 V, I _O = 3.0 mA)						V	
Double Voltage	12	V _{BBD}	4.6	5.0	-		
Triple Voltage	11	V _{BBT}	6.1	7.0	-		
Triple Voltage (V _{CC} = 7.2 V, I _O = 3.0 mA)	11	V _{BBT}	-	11.2	-		
NEGATIVE GENERATOR OUTPUT							
Output Voltage (I _O = 3.0 mA)	4	V _O	-3.75	-4.0	-4.25	V	
Output Voltage Ripple with Filter (R _f = 33 Ω, C _f = 4.7 μF) (I _O = 0 to 5.0 mA)	4	V _r	-	2.0	-	mVpp	
PRIORITY MANAGEMENT SECTION							
Idle Mode Input	13						
Input Voltage High State (Logic 1)		V _{IH}	2.0	-	2.7	V	
Input Voltage Low State (Logic 0)		V _{IL}	0	-	0.5	V	
Input Current High State (Logic 1)		I _{IH}	10	-	80	μA	
Input Current Low State (Logic 0), i.e. Standby Mode		I _{IL}	-	-	1.0	μA	
T _x Power Control Input	9						
Input Voltage Range		VT _x	0	-	3.1	V	
Input Voltage "Off" State (Zero RF Output Level)		VT _{x(off)}	-	0.7	-	V	
Input Voltage "On" State (Maximum RF Output Level)		VT _{x(on)}	-	2.7	-	V	
Input Resistance		R _{in}	-	90	-	kΩ	
Bandwidth (-3.0 dB)		B	-	1.0	-	MHz	
Gate Drive Output	8						
Voltage (VT _x = 0 V)		V _{GO}	-	-	0.5	V	
(VT _x = 3.0 V)			V _{CC} +2.7	-	-		
Peak Current (Source and Sink) (VT _x = 3.0 V)		I _{GO}	-	3.0	-	mA	
Undervoltage Lockout Voltage on Sense Input (Magnitude)	10	V _{sense}	-3.0	-3.2	-	V	

MC33169–4.0

ELECTRICAL CHARACTERISTICS (continued) ($V_{CC} = 4.8$ V. For typical values $T_A = 25^\circ\text{C}$, for min/max values T_A is the operating ambient temperature range that applies, unless otherwise noted.)

Characteristic	Pin	Symbol	Min	Typ	Max	Unit
TOTAL DEVICE POWER CONSUMPTION						
I_{CC} Operating ($V_{T_X} = 3.0$ V, $I_O = 3.0$ mA)	–	I_{CC}	–	10	15	mA
I_{CC} Operating ($V_{T_X} = 0$ V, $I_O = 3.0$ mA)	–	I_{CC}	–	12	15	mA
($V_{T_X} = 0$ V, $I_O = 0$ mA)	–		–	4.0	5.0	
Standby Mode (Idle Mode Input = 0 V)	–	I_{CC}	–	–	1.0	μA

MC33169–4.0

ELECTRICAL CHARACTERISTICS ($V_{CC} = 2.7$ V. For typical values $T_A = 25^\circ\text{C}$, for min/max values T_A is the operating ambient temperature range that applies, unless otherwise noted.)

Characteristic	Pin	Symbol	Min	Typ	Max	Unit
V_{BB} GENERATOR (VOLTAGE TRIPLER)						
Oscillator Frequency	–	f_{osc}	90	100	110	kHz
Oscillator Duty Cycle	–	DC	35	50	65	%
Output Voltage ($V_{CC} = 3.0$ V, $I_O = 3.0$ mA)						V
Double Voltage	12	V_{BBD}	4.6	5.0	–	
Triple Voltage	11	V_{BBT}	6.1	7.0	–	
Triple Voltage ($V_{CC} = 7.2$ V, $I_O = 3.0$ mA)	11	V_{BBT}	–	11.2	–	

NEGATIVE GENERATOR OUTPUT

Output Voltage ($I_O = 1.0$ mA)	4	V_O	–3.75	–4.0	–4.25	V
Output Voltage Ripple with Filter ($R_f = 33$ Ω , $C_f = 4.7$ μF) ($I_O = 0$ to 5.0 mA)	4	V_r	–	2.0	–	mVpp

PRIORITY MANAGEMENT SECTION

Idle Mode Input	13					
Input Voltage High State (Logic 1)		V_{IH}	2.0	–	2.7	V
Input Voltage Low State (Logic 0)		V_{IL}	0	–	0.5	V
Input Current High State (Logic 1)		I_{IH}	10	–	80	μA
Input Current Low State (Logic 0), i.e. Standby Mode		I_{IL}	–	–	1.0	μA
T_X Power Control Input	9					
Input Voltage Range		V_{T_X}	0	–	3.0	V
Input Voltage “Off” State (Zero RF Output Level)		$V_{T_X(off)}$	–	0.7	–	V
Input Voltage “On” State (Maximum RF Output Level)		$V_{T_X(on)}$	–	2.7	–	V
Input Resistance		R_{in}	–	90	–	k Ω
Bandwidth (–3.0 dB)		B	–	1.0	–	MHz
Gate Drive Output	8					
Voltage ($V_{T_X} = 0$ V)		V_{GO}	–	–	0.5	V
($V_{T_X} = 3.0$ V)			$V_{CC}+2.7$	–	–	
Peak Current (Source and Sink) ($V_{T_X} = 3.0$ V)		I_{GO}	–	3.0	–	mA
Undervoltage Lockout Voltage on Sense Input (Magnitude)	10	V_{sense}	–3.0	–3.2	–	V

TOTAL DEVICE POWER CONSUMPTION

I_{CC} Operating ($V_{T_X} = 3.0$ V)	14	I_{CC}	–	–	15	mA
($I_O = 3.0$ mA)			–	–	9.0	
($I_O = 1.0$ mA)			–	–	–	
I_{CC} Operating ($V_{T_X} = 0$ V)	14	I_{CC}	–	–	13	mA
($I_O = 3.0$ mA)			–	–	9.0	
($I_O = 1.0$ mA)			–	4.5	6.0	
($I_O = 0$ mA)			–	–	–	
Standby Mode (Idle Mode Input = 0 V)	14	I_{CC}	–	–	1.0	μA

MC33169–2.5

ELECTRICAL CHARACTERISTICS ($V_{CC} = 4.8$ V. For typical values $T_A = 25^\circ\text{C}$, for min/max values T_A is the operating ambient temperature range that applies, unless otherwise noted.)

Characteristic	Pin	Symbol	Min	Typ	Max	Unit
V_{BB} GENERATOR (VOLTAGE TRIPLER)						
Oscillator Frequency	–	f_{osc}	90	100	110	kHz
Oscillator Duty Cycle	–	DC	35	50	65	%
Output Voltage ($V_{CC} = 3.0$ V, $I_O = 3.0$ mA)						V
Double Voltage	12	V_{BBD}	4.6	5.0	–	
Triple Voltage	11	V_{BBT}	6.1	7.0	–	
Triple Voltage ($V_{CC} = 7.2$ V, $I_O = 3.0$ mA)	11	V_{BBT}	–	11.2	–	

NEGATIVE GENERATOR OUTPUT

Output Voltage ($I_O = 3.0$ mA) ($I_O = 5.0$ mA, $V_{CC} = 6.0$ V)	4	V_O	–2.35 –	–2.5 –2.5	–2.65 –	V
Output Voltage Ripple with Filter ($R_f = 33$ Ω , $C_f = 4.7$ μF) ($I_O = 0$ to 5.0 mA)	4	V_r	–	2.0	8.0	mVpp

PRIORITY MANAGEMENT SECTION

Idle Mode Input	13					
Input Voltage High State (Logic 1)		V_{IH}	2.0	–	2.7	V
Input Voltage Low State (Logic 0)		V_{IL}	0	–	0.5	V
Input Current High State (Logic 1)		I_{IH}	10	–	80	μA
Input Current Low State (Logic 0), i.e. Standby Mode		I_{IL}	–	–	1.0	μA
T_X Power Control Input	9					
Input Voltage Range		V_{T_X}	0	–	3.0	V
Input Voltage “Off” State (Zero RF Output Level)		$V_{T_X(\text{off})}$	–	0.7	–	V
Input Voltage “On” State (Maximum RF Output Level)		$V_{T_X(\text{on})}$	–	2.7	–	V
Input Resistance		R_{in}	–	90	–	$k\Omega$
Bandwidth (–3.0 dB)		B	–	1.0	–	MHz
Gate Drive Output	8					
Voltage ($V_{T_X} = 0$ V)		V_{GO}	–	–	0.5	V
($V_{T_X} = 3.0$ V)			$V_{CC}+2.7$	–	–	
Peak Current ($V_{T_X} = 3.0$ V)		I_{GO}	–	3.0	–	mA
Undervoltage Lockout Voltage on Sense Input (Magnitude)	10	V_{sense}	–2.0	–2.3	–	V

TOTAL DEVICE POWER CONSUMPTION

I_{CC} Operating ($V_{T_X} = 3.0$ V, $I_O = 3.0$ mA)	14	I_{CC}	–	14	17	mA
I_{CC} Operating ($V_{T_X} = 0$ V, $I_O = 3.0$ mA)	14	I_{CC}	–	13.5	16	mA
($V_{T_X} = 0$ V, $I_O = 0$ mA)			–	4.5	6.0	
Standby Mode (Idle Mode Input = 0 V)	14	I_{CC}	–	–	1.0	μA

PRIORITY MANAGEMENT TRUTH TABLE

Control Inputs		Outputs	
Idle Mode	T_X Power Control	V_O	Gate Drive
0	0	Off	0.5 V max
1	0	–2.5 or –4.0 V	0.5 V max
0	1	Off	0.5 V max
1	1	–2.5 or –4.0 V	$V_{CC} + 2.7$ V min

Figure 2. Operating Current versus Temperature

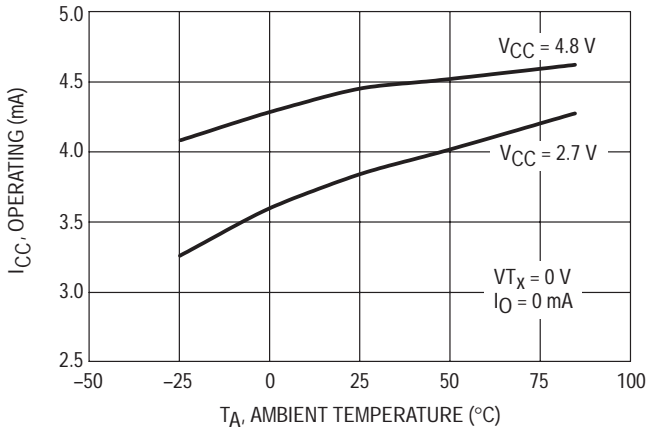

Figure 3. Operating Current versus Temperature

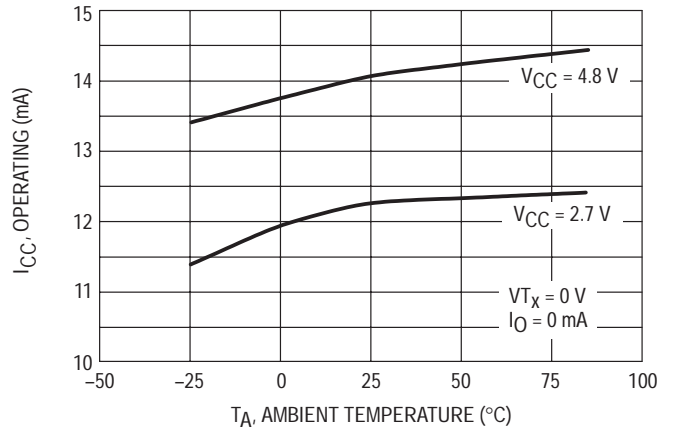

Figure 4. Operating Current versus Temperature

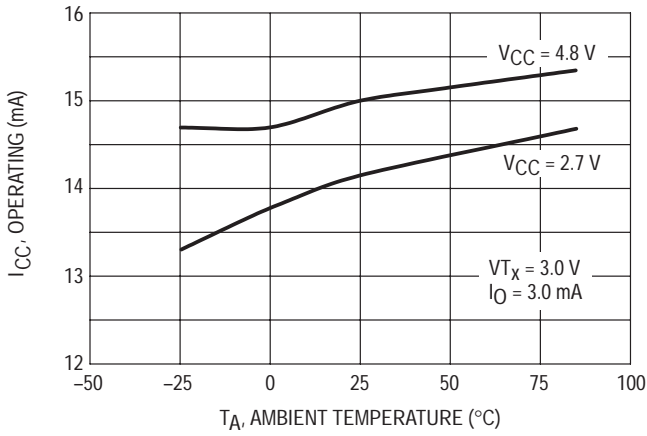

Figure 5. Operating Current versus Temperature

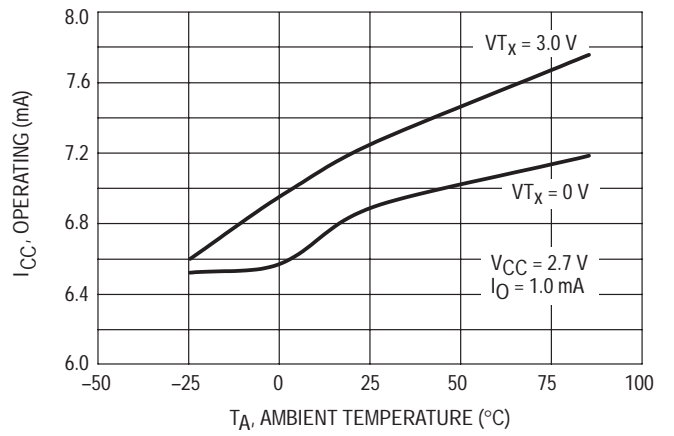

Figure 6. Output Voltage versus Temperature

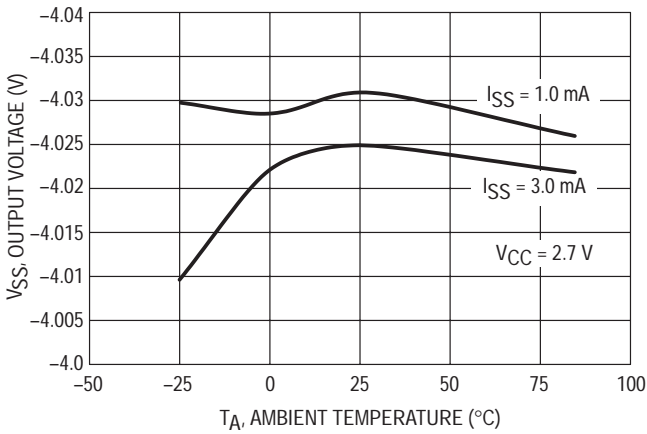

Figure 7. Output Voltage versus Temperature

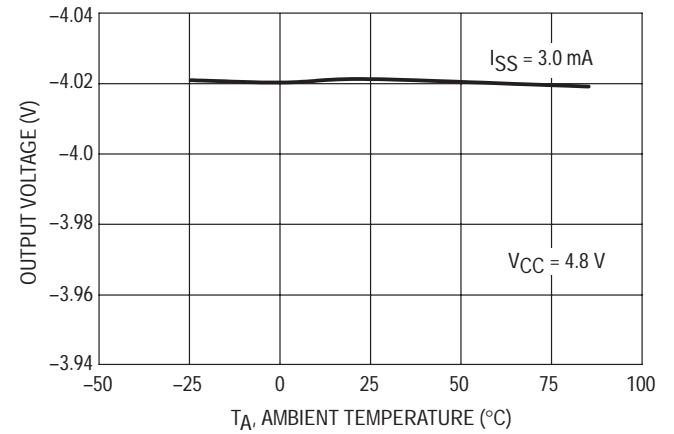
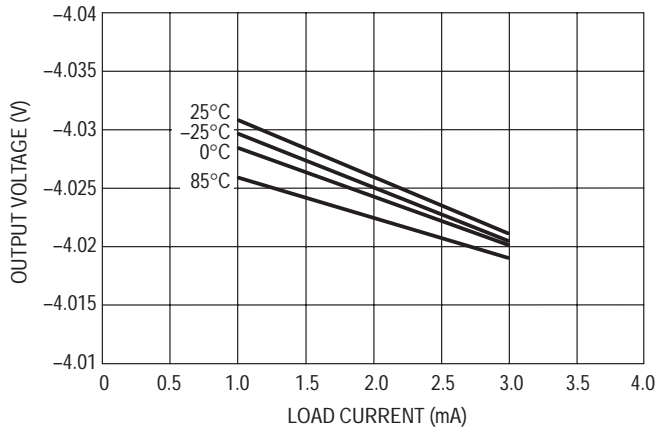
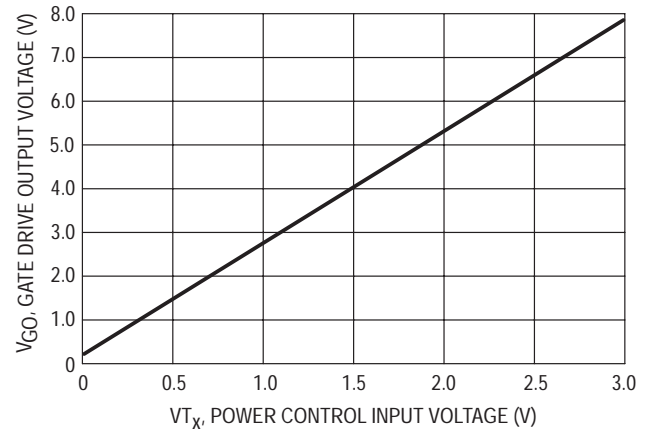

Figure 8. Output Voltage versus Load Current

Figure 9. V_{T_x} Control Voltage versus Gate Drive Output Voltage

OPERATING DESCRIPTION

The MC33169 is a power amplifier support IC that is designed to properly switch "on" or "off" a MESFET Power Amplifier either manually or by microprocessor. Controlling the power drain of the RF Amplifier extends operating battery life in many portable systems.

Outputs

The IC is designed to provide a -4.0 V or -2.5 V bias to the gate of the RF Amplifier MESFET devices prior to application of a positive battery voltage to the drain. The negative output voltage can provide up to 5.0 mA of current. The positive voltage control requires an external N-Channel logic level MOSFET, connected as a source follower. The Gate Drive Output, Pin 8, can source or sink 3.0 mA to the external MOSFET. The low drive current slows the MOSFET switching speed, thereby minimizing voltage

glitches on the V_{CC} line which could cause disturbances to other circuitry.

Inputs

A Sense Input, Pin 10, protects the Power Amplifier load by monitoring the level of the negative output voltage. If the negative voltage magnitude falls below a preset level, 3.2 V typical for the -4.0 V version or 2.3 V for the -2.5 V version, an undervoltage lockout circuit disables the external MOSFET gate drive.

The T_x Power Control Input controls the N-Channel external switching MOSFET in source follower mode, which allows linear control of the RF Output voltage level.

The Idle mode input is CMOS compatible, allowing the RF Amplifier to be placed in a standby mode, drawing less than 1.0 μ A from the power source.

MC33169

Figure 10. Class 4 GSM with a Two-Stage Integrated Power Amplifier (I.P.A.)

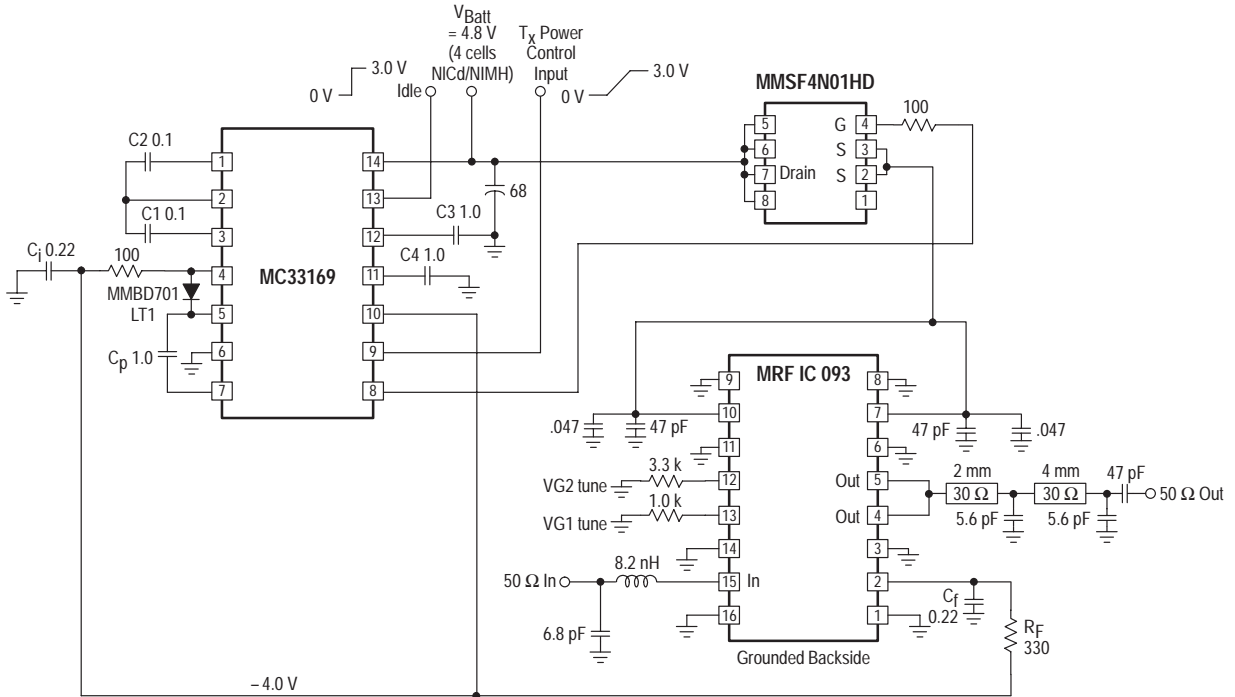
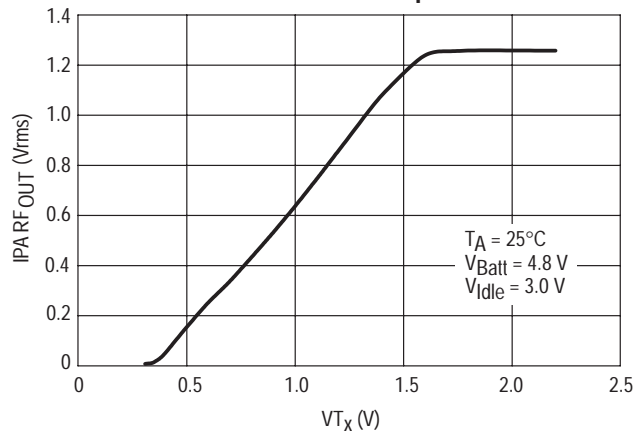

Figure 11. Transfer Characteristic for Gate Drive Output



$V_{Batt} = 4.8 V$
 $P_{in} = 10 dBm$
 $V_{Idle} = 3.0 V$

V_{ramp} : 40 Hz sinusoidal voltage set for 95% AM depth on RF

Peak output power: 34.6 dBm

CURVES RELATED TO APPLICATION GSM CLASS 4

Figure 12. RF Output Voltage (40 Hz/95% AM) and V_{T_x} Driving Voltage

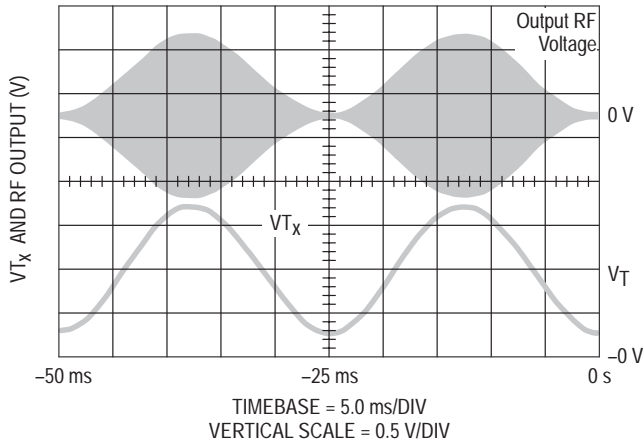

Figure 13. Idle, PA Drain, RF Output and V_O Voltages During a Burst Period

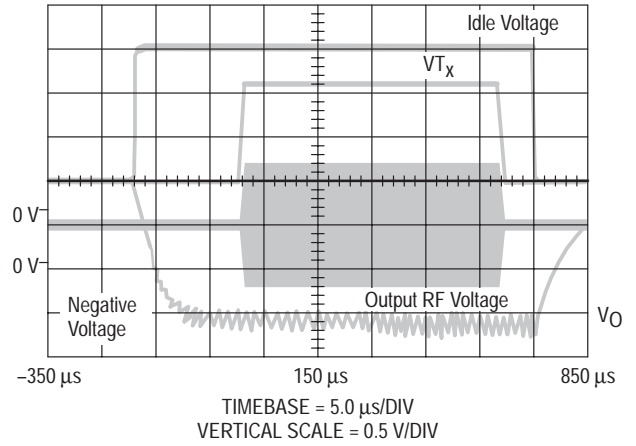

Figure 14. RF Output Voltage, PA Drain Voltage and V_{T_x} Driving Voltage, During Fall Time

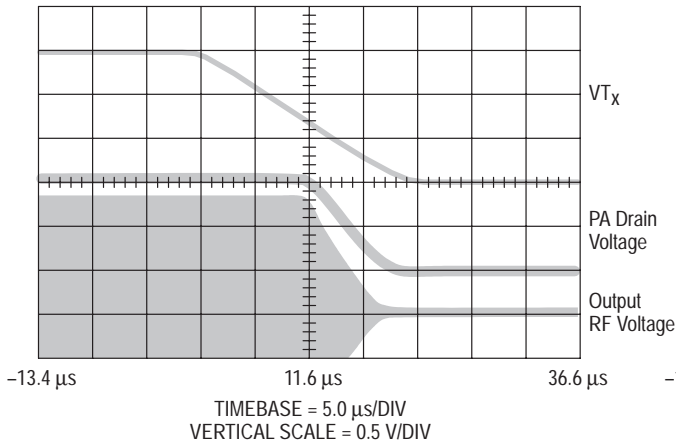
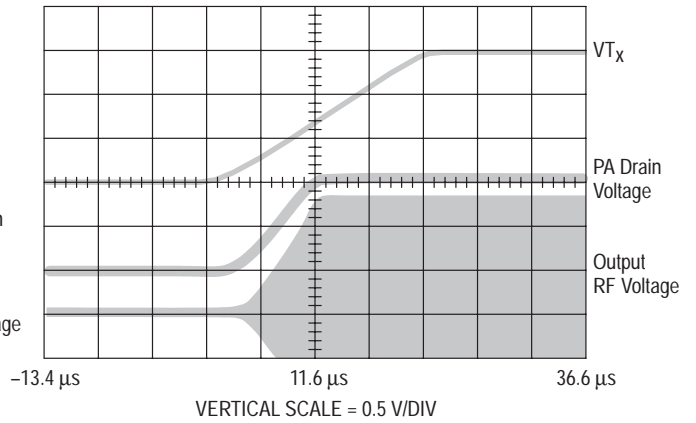

Figure 15. RF Output Voltage, PA Drain Voltage and V_{T_x} Driving Voltage, During Rise Time



MC33169

Figure 16. AMPS version with MRFIC0913, Integrated Power Amplifier (I.P.A.)

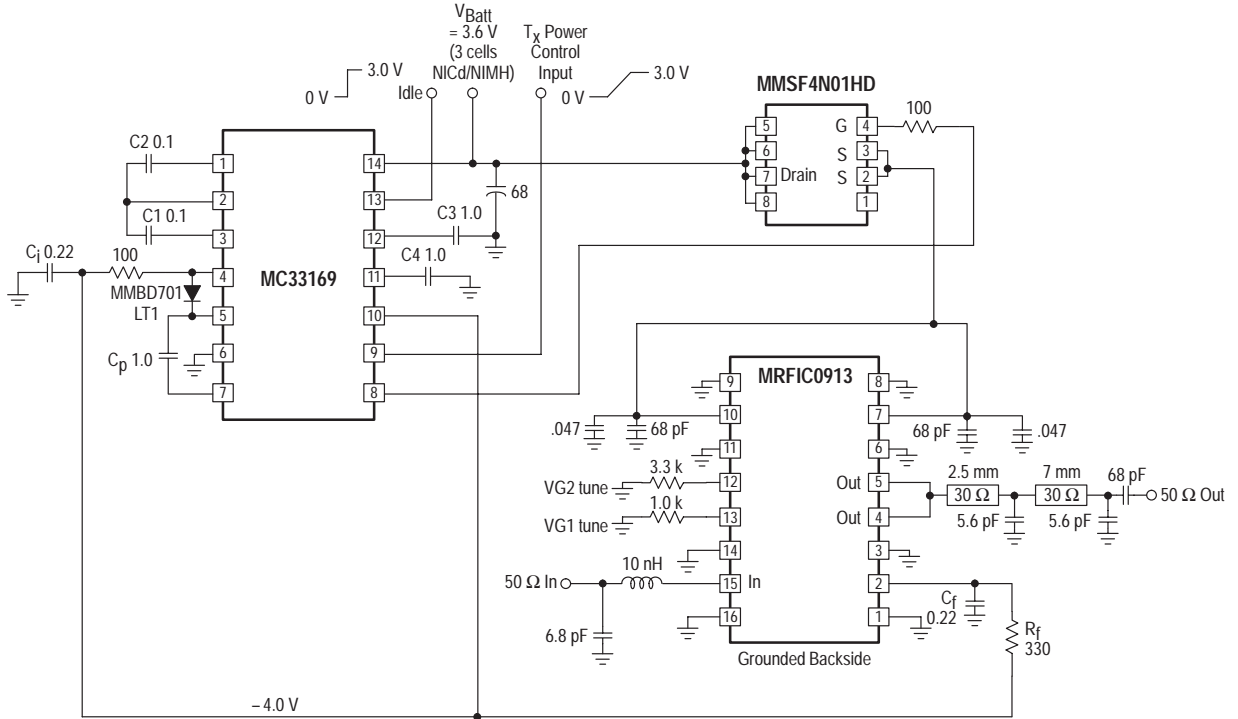
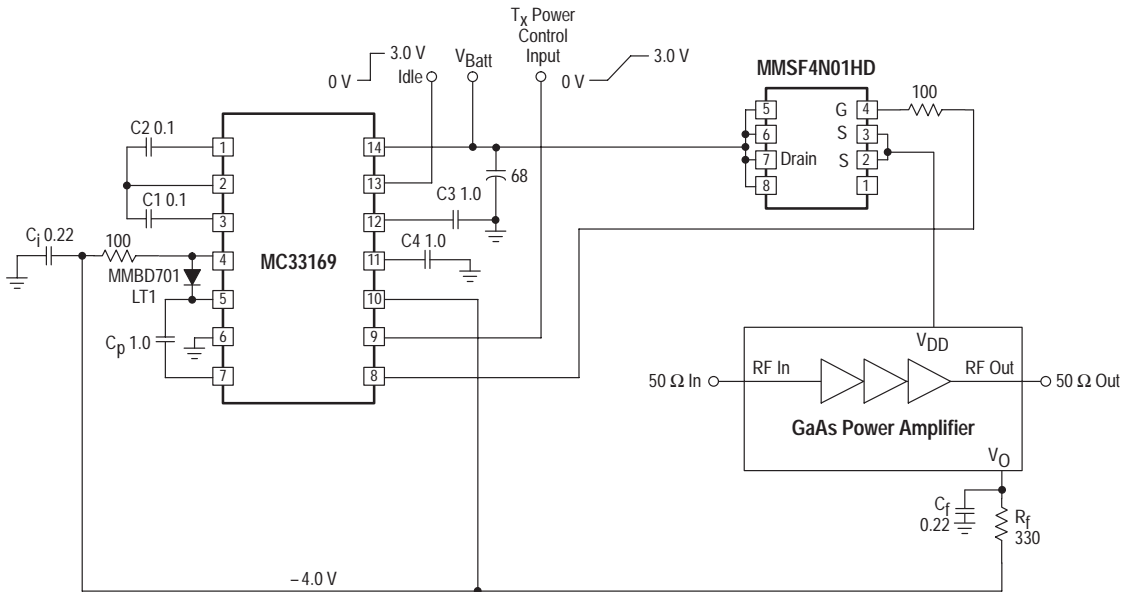

Figure 17. MC33169 with GaAs RF Power Amplifier



Tape and Reel Options

In Brief . . .

Motorola offers the convenience of Tape and Reel packaging for our growing family of standard integrated circuit products. Reels are available to support the requirements of both first and second generation pick-and-place equipment. The packaging fully conforms to the latest EIA-481A specification. The antistatic embossed tape provides a secure cavity, sealed with a peel-back cover tape.

	Page
Tape and Reel Configurations	12-2
Tape and Reel Information Table	12-4
Analog MPQ Table	12-5

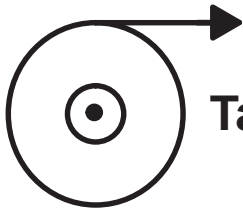

Tape and Reel Configurations

Mechanical Polarization

SOIC and Micro-8 DEVICES

Typical

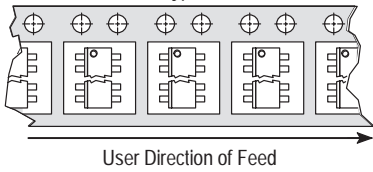

PLCC DEVICES

Typical

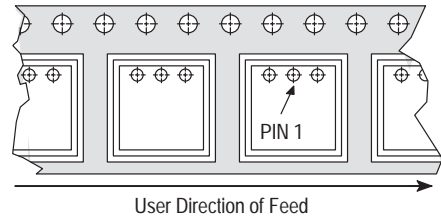

DPAK and D²PAK DEVICES

Typical

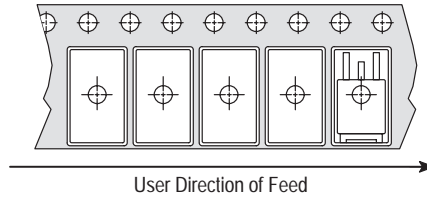

SOT-23 (5 Pin) DEVICES

Typical

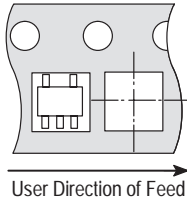

SOT-89 (3 Pin) DEVICES

Typical

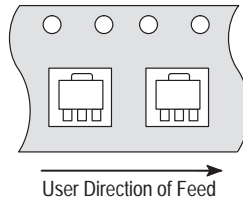

SOT-89 (5 Pin) DEVICES

Typical

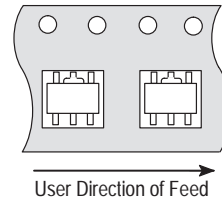

Tape and Reel Configurations (continued)

TO-92 Reel Styles

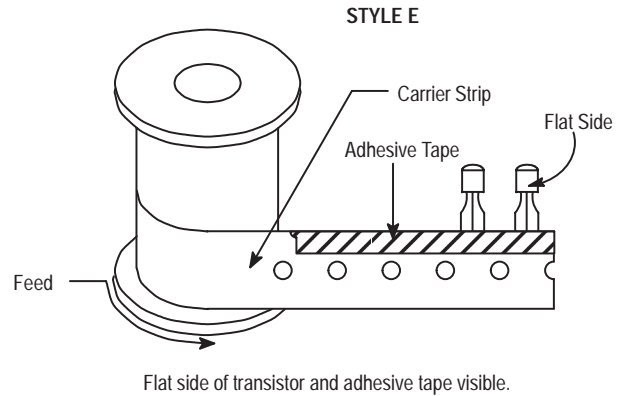
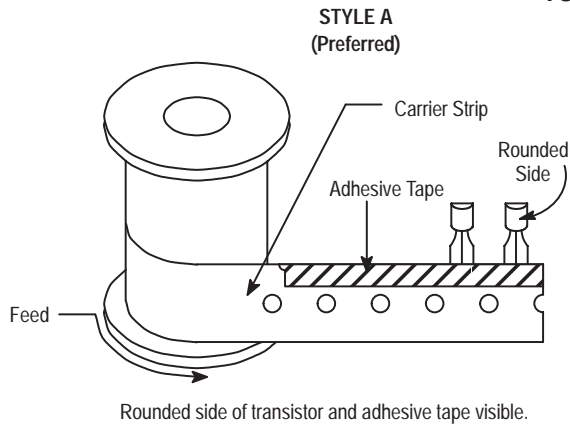

TO-92 Ammo Pack Styles

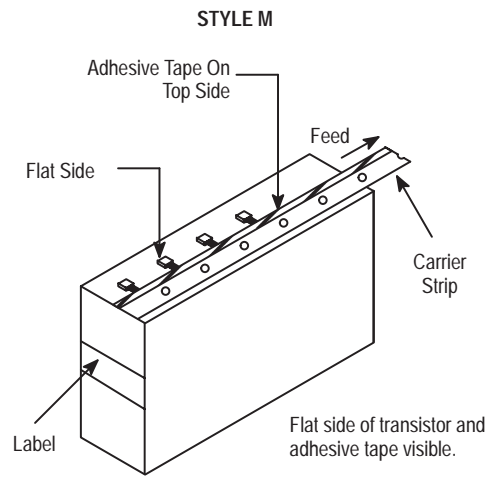
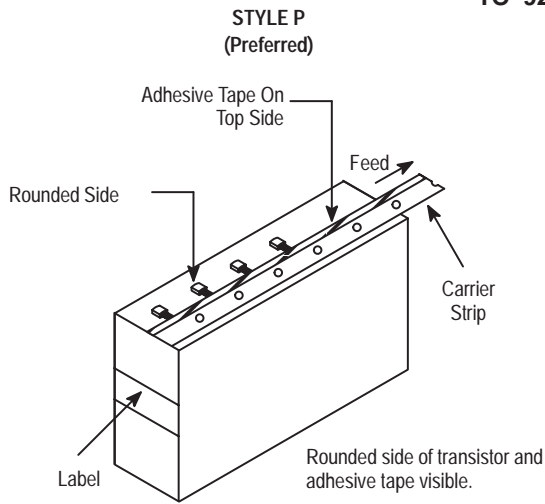

Style P ammo pack is equivalent to Styles A and B of reel pack dependent on feed orientation from box.

Style M ammo pack is equivalent to Style E of reel pack dependent on feed orientation from box.

TO-92 EIA Radial Tape in Fan Fold Box or On Reel

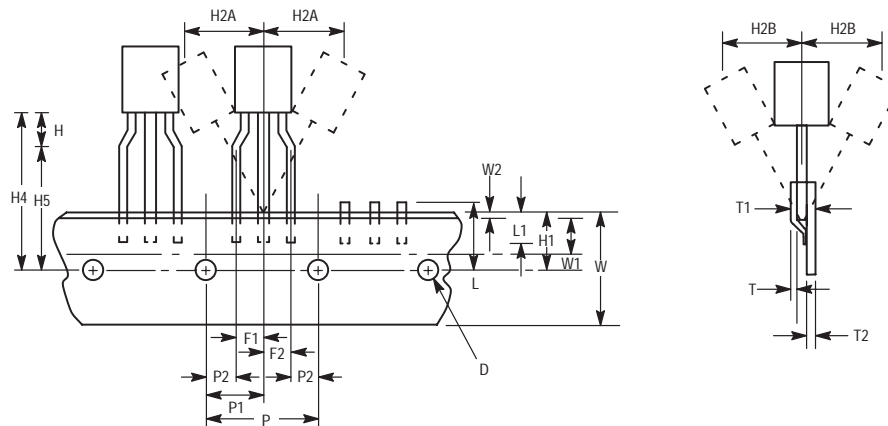

Tape and Reel Information Table

Package	Tape Width (mm)	Devices ⁽¹⁾ per Reel	Reel Size (inch)	Device Suffix
SO-8, SOP-8	12	2,500	13	R2
SO-14	16	2,500	13	R2
SO-16	16	2,500	13	R2
SO-16L, SO-8+8L WIDE	16	1,000	13	R2
SO-20L WIDE	24	1,000	13	R2
SO-24L WIDE	24	1,000	13	R2
SO-28L WIDE	24	1,000	13	R2
SO-28L WIDE	32	1,000	13	R3
Micro-8	12	2,500	13	R2
PLCC-20	16	1,000	13	R2
PLCC-28	24	500	13	R2
PLCC-44	32	500	13	R2
PLCC-52	32	500	13	R2
PLCC-68	44	250	13	R2
PLCC-84	44	250	13	R2
TO-226AA (TO-92) ⁽²⁾	18	2,000	13	RA, RE, RP, or RM (Ammo Pack) only
DPAK	16	2,500	13	RK
D ² PAK	24	800	13	R4
SOT-23 (5 Pin)	8	3,000	7	TR
SOT-89 (3/5 Pin)	12	1,000	7	T1

⁽¹⁾ Minimum order quantity is 1 reel. Distributors/OEM customers may break lots or reels at their option, however broken reels may not be returned.

⁽²⁾ Integrated circuits in TO-226AA packages are available in Styes A and E only, with optional "Ammo Pack" (Suffix RP or RM). The RA and RP configurations are preferred. For ordering information please contact your local Motorola Semiconductor Sales Office.

Analog MPQ Table

Tape/Reel and Ammo Pack

Package Type	Package Code	MPQ
PLCC		
Case 775	0802	1000/reel
Case 776	0804	500/reel
Case 777	0801	500/reel
SOIC		
Case 751	0095	2500/reel
Case 751A	0096	2500/reel
Case 751B	0097	2500/reel
Case 751G	2003	1000/reel
Case 751D	2005	1000/reel
Case 751E	2008	1000/reel
Case 751F	2009	1000/reel
Micro-8		
Case 846A	-	2500/reel
TO-92		
Case 29	0031	2000/reel
Case 29	0031	2000/Ammo Pack
DPAK		
Case 369A	-	2500/reel
D2PAK		
Case 936	-	800/reel
SOT-23 (5 Pin)		
Case 1212	-	3000/reel
SOT-89 (3 Pin)		
Case 1213	-	1000/reel
SOT-89 (5 Pin)		
Case 1214	-	1000/reel

Packaging Information

In Brief . . .

The packaging availability for each device type is indicated on the individual data sheets and the Selector Guide. All of the outline dimensions for the packages are given in this section.

The maximum power consumption an integrated circuit can tolerate at a given operating ambient temperature can be found from the equation:

$$P_{D(TA)} = \frac{T_{J(max)} - T_A}{R_{\theta JA(Typ)}}$$

where:

$P_{D(TA)}$ = *Power Dissipation allowable at a given operating ambient temperature. This must be greater than the sum of the products of the supply voltages and supply currents at the worst case operating condition.*

$T_{J(max)}$ = *Maximum operating Junction Temperature as listed in the Maximum Ratings Section. See individual data sheets for $T_{J(max)}$ information.*

T_A = *Maximum desired operating Ambient Temperature*

$R_{\theta JA(Typ)}$ = *Typical Thermal Resistance Junction-to-Ambient*

Case Outline Dimensions

LP, P, Z SUFFIX
CASE 29-04
 Plastic Package
 (TO-226AA/TO-92)
 ISSUE AD

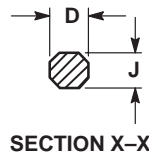
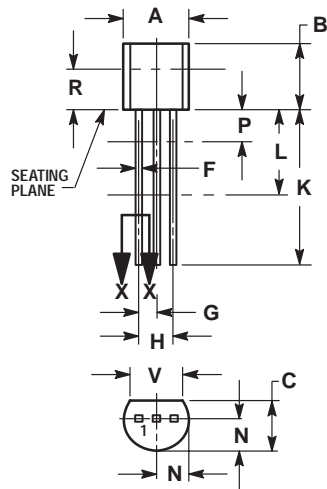
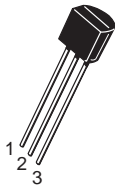

NOTES:

1. DIMENSIONING AND TOLERANCING PER ANSI Y14.5M, 1982.
2. CONTROLLING DIMENSION: INCH.
3. CONTOUR OF PACKAGE BEYOND DIMENSION R IS UNCONTROLLED.
4. DIMENSION F APPLIES BETWEEN P AND L. DIMENSION D AND J APPLY BETWEEN L AND K MINIMUM. LEAD DIMENSION IS UNCONTROLLED IN P AND BEYOND DIMENSION K MINIMUM.

DIM	INCHES		MILLIMETERS	
	MIN	MAX	MIN	MAX
A	0.175	0.205	4.45	5.20
B	0.170	0.210	4.32	5.33
C	0.125	0.165	3.18	4.19
D	0.016	0.022	0.41	0.55
F	0.016	0.019	0.41	0.48
G	0.045	0.055	1.15	1.39
H	0.095	0.105	2.42	2.66
J	0.015	0.020	0.39	0.50
K	0.500	---	12.70	---
L	0.250	---	6.35	---
N	0.080	0.105	2.04	2.66
P	---	0.100	---	2.54
R	0.115	---	2.93	---
V	0.135	---	3.43	---

KC, T SUFFIX
CASE 221A-06
 Plastic Package
 ISSUE Y

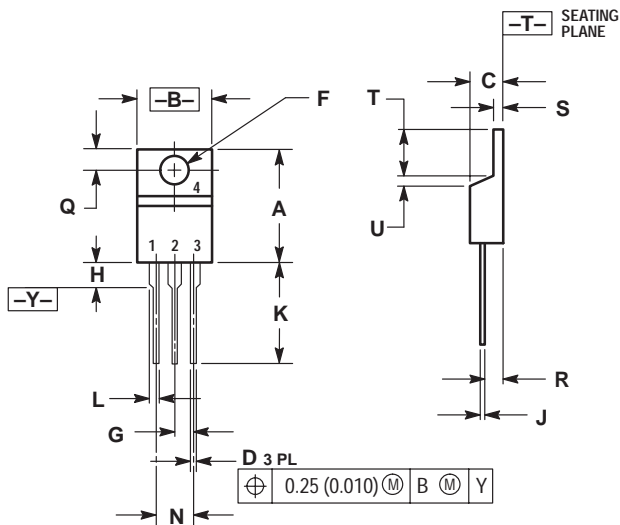
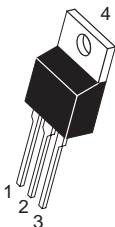

NOTES:

1. DIMENSIONING AND TOLERANCING PER ANSI Y14.5M, 1982.
2. CONTROLLING DIMENSION: INCH.

DIM	INCHES		MILLIMETERS	
	MIN	MAX	MIN	MAX
A	0.560	0.625	14.23	15.87
B	0.380	0.420	9.66	10.66
C	0.140	0.190	3.56	4.82
D	0.020	0.045	0.51	1.14
F	0.139	0.155	3.53	3.93
G	0.100 BSC	---	2.54 BSC	---
H	---	0.280	---	7.11
J	0.012	0.045	0.31	1.14
K	0.500	0.580	12.70	14.73
L	0.045	0.070	1.15	1.77
N	0.200 BSC	---	5.08 BSC	---
Q	0.100	0.135	2.54	3.42
R	0.080	0.115	2.04	2.92
S	0.020	0.055	0.51	1.39
T	0.235	0.255	5.97	6.47
U	0.000	0.050	0.00	1.27

TH SUFFIX
CASE 314A-03
 Plastic Package
 ISSUE D

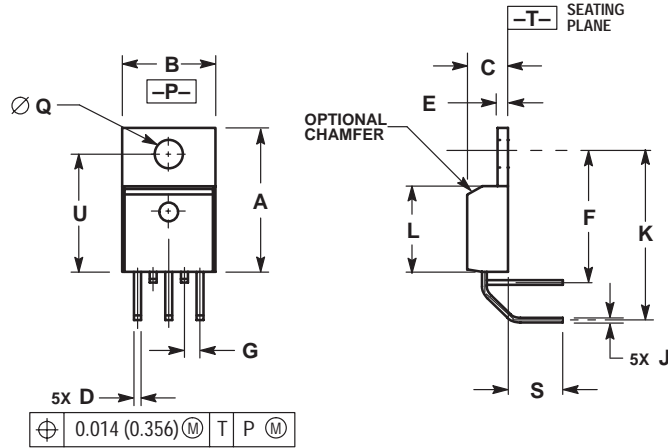
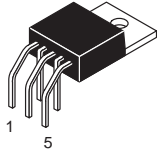

- NOTES:
1. DIMENSIONING AND TOLERANCING PER ANSI Y14.5M, 1982.
 2. CONTROLLING DIMENSION: INCH.
 3. DIMENSION D DOES NOT INCLUDE INTERCONNECT BAR (DAMBAR) PROTRUSION. DIMENSION D INCLUDING PROTRUSION SHALL NOT EXCEED 0.043 (1.092) MAXIMUM.

DIM	INCHES		MILLIMETERS	
	MIN	MAX	MIN	MAX
A	0.572	0.613	14.529	15.570
B	0.390	0.415	9.906	10.541
C	0.170	0.180	4.318	4.572
D	0.025	0.038	0.635	0.965
E	0.048	0.055	1.219	1.397
F	0.570	0.585	14.478	14.859
G	0.067 BSC		1.702 BSC	
J	0.015	0.025	0.381	0.635
K	0.730	0.745	18.542	18.923
L	0.320	0.365	8.128	9.271
Q	0.140	0.153	3.556	3.886
S	0.210	0.260	5.334	6.604
U	0.468	0.505	11.888	12.827

T, TV SUFFIX
CASE 314B-05
 Plastic Package
 ISSUE J

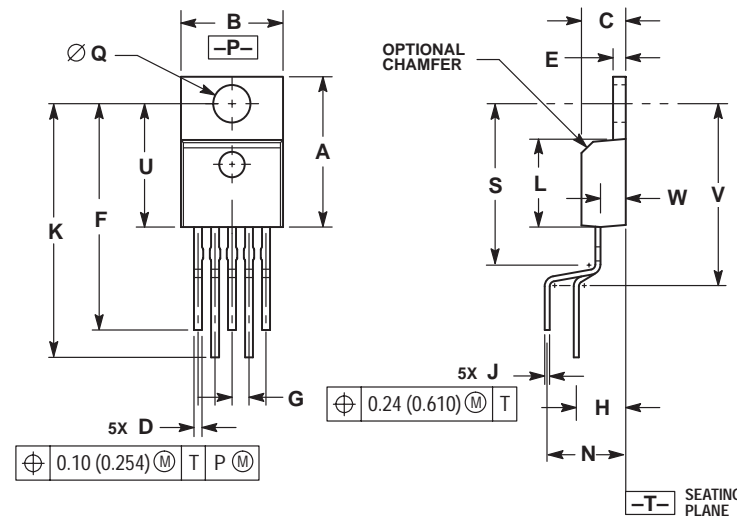
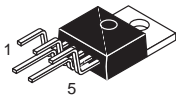

- NOTES:
1. DIMENSIONING AND TOLERANCING PER ANSI Y14.5M, 1982.
 2. CONTROLLING DIMENSION: INCH.
 3. DIMENSION D DOES NOT INCLUDE INTERCONNECT BAR (DAMBAR) PROTRUSION. DIMENSION D INCLUDING PROTRUSION SHALL NOT EXCEED 0.043 (1.092) MAXIMUM.

DIM	INCHES		MILLIMETERS	
	MIN	MAX	MIN	MAX
A	0.572	0.613	14.529	15.570
B	0.390	0.415	9.906	10.541
C	0.170	0.180	4.318	4.572
D	0.025	0.038	0.635	0.965
E	0.048	0.055	1.219	1.397
F	0.850	0.935	21.590	23.749
G	0.067 BSC		1.702 BSC	
H	0.166 BSC		4.216 BSC	
J	0.015	0.025	0.381	0.635
K	0.900	1.100	22.860	27.940
L	0.320	0.365	8.128	9.271
N	0.320 BSC		8.128 BSC	
Q	0.140	0.153	3.556	3.886
S	---	0.620	---	15.748
U	0.468	0.505	11.888	12.827
V	---	0.735	---	18.669
W	0.090	0.110	2.286	2.794

T SUFFIX
CASE 314C-01
 Plastic Package
 ISSUE A

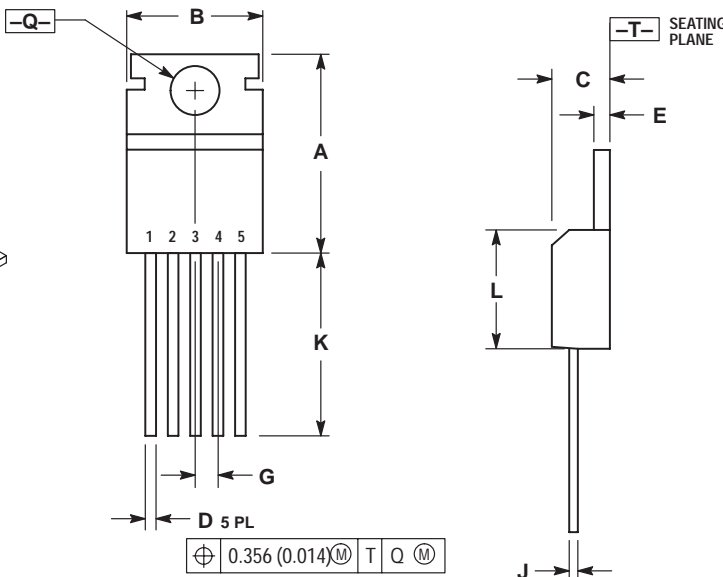
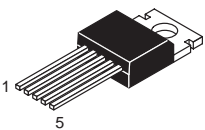

- NOTES:
1. DIMENSIONING AND TOLERANCING PER ANSI Y14.5M, 1982.
 2. CONTROLLING DIMENSION: INCH.
 3. DIMENSION D DOES NOT INCLUDE INTERCONNECT BAR (DAMBAR) PROTRUSION. DIMENSION D INCLUDING PROTRUSION SHALL NOT EXCEED 10.92 (0.043) MAXIMUM.

DIM	INCHES		MILLIMETERS	
	MIN	MAX	MIN	MAX
A	0.610	0.625	15.59	15.88
B	0.380	0.420	9.65	10.67
C	0.160	0.190	4.06	4.83
D	0.020	0.040	0.51	1.02
E	0.035	0.055	0.89	1.40
G	0.067 BSC		1.702 BSC	
J	0.015	0.025	0.38	0.64
K	0.500	---	12.70	---
L	0.355	0.370	9.02	9.40
Q	0.139	0.147	3.53	3.73

T, T1 SUFFIX
CASE 314D-03
 Plastic Package
 ISSUE D

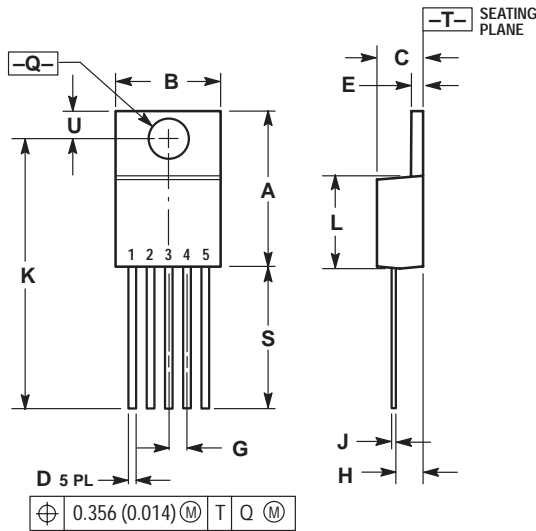
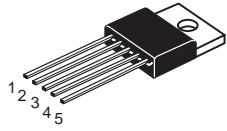

- NOTES:
1. DIMENSIONING AND TOLERANCING PER ANSI Y14.5M, 1982.
 2. CONTROLLING DIMENSION: INCH.
 3. DIMENSION D DOES NOT INCLUDE INTERCONNECT BAR (DAMBAR) PROTRUSION. DIMENSION D INCLUDING PROTRUSION SHALL NOT EXCEED 10.92 (0.043) MAXIMUM.

DIM	INCHES		MILLIMETERS	
	MIN	MAX	MIN	MAX
A	0.572	0.613	14.529	15.570
B	0.390	0.415	9.906	10.541
C	0.170	0.180	4.318	4.572
D	0.025	0.038	0.635	0.965
E	0.048	0.055	1.219	1.397
G	0.067 BSC		1.702 BSC	
H	0.087	0.112	2.210	2.845
J	0.015	0.025	0.381	0.635
K	1.020	1.065	25.908	27.051
L	0.320	0.365	8.128	9.271
Q	0.140	0.153	3.556	3.886
U	0.105	0.117	2.667	2.972
S	0.543	0.582	13.792	14.783

$\oplus 0.356 (0.014) \text{ (M) T Q (M)}$

DT-1 SUFFIX
CASE 369-07
 Plastic Package (DPAK)
 ISSUE K

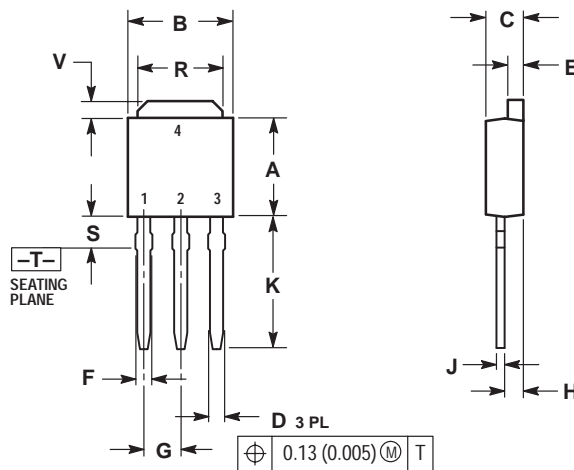
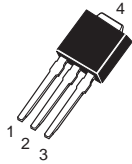

- NOTES:
1. DIMENSIONING AND TOLERANCING PER ANSI Y14.5M, 1982.
 2. CONTROLLING DIMENSION: INCH.

DIM	INCHES		MILLIMETERS	
	MIN	MAX	MIN	MAX
A	0.235	0.250	5.97	6.35
B	0.250	0.265	6.35	6.73
C	0.086	0.094	2.19	2.38
D	0.027	0.035	0.69	0.88
E	0.033	0.040	0.84	1.01
F	0.037	0.047	0.94	1.19
G	0.090 BSC		2.29 BSC	
H	0.034	0.040	0.87	1.01
J	0.018	0.023	0.46	0.58
K	0.350	0.380	8.89	9.65
R	0.175	0.215	4.45	5.46
S	0.050	0.090	1.27	2.28
V	0.030	0.050	0.77	1.27

$\oplus 0.13 (0.005) \text{ (M) T}$

DT SUFFIX
CASE 369A-13
 Plastic Package (DPAK)
 ISSUE Y

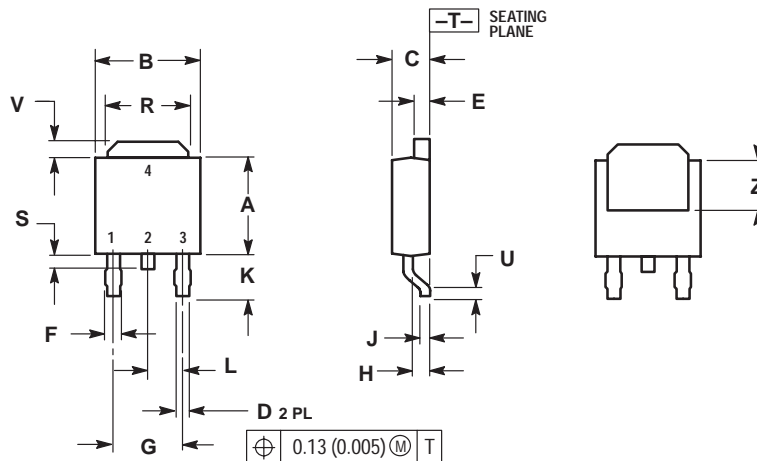
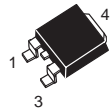

- NOTES:
1. DIMENSIONING AND TOLERANCING PER ANSI Y14.5M, 1982.
 2. CONTROLLING DIMENSION: INCH.

DIM	INCHES		MILLIMETERS	
	MIN	MAX	MIN	MAX
A	0.235	0.250	5.97	6.35
B	0.250	0.265	6.35	6.73
C	0.086	0.094	2.19	2.38
D	0.027	0.035	0.69	0.88
E	0.033	0.040	0.84	1.01
F	0.037	0.047	0.94	1.19
G	0.180 BSC		4.58 BSC	
H	0.034	0.040	0.87	1.01
J	0.018	0.023	0.46	0.58
K	0.102	0.114	2.60	2.89
L	0.090 BSC		2.29 BSC	
R	0.175	0.215	4.45	5.46
S	0.020	0.050	0.51	1.27
U	0.020	---	0.51	---
V	0.030	0.050	0.77	1.27
Z	0.138	---	3.51	---

$\oplus 0.13 (0.005) \text{ (M) T}$

DP1, N, P, P1 SUFFIX
CASE 626-05
 Plastic Package
 ISSUE K

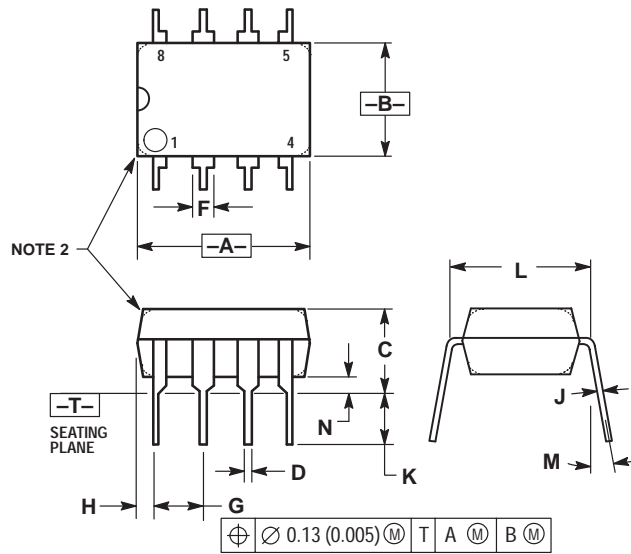
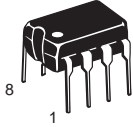

- NOTES:
1. DIMENSION L TO CENTER OF LEAD WHEN FORMED PARALLEL.
 2. PACKAGE CONTOUR OPTIONAL (ROUND OR SQUARE CORNERS).
 3. DIMENSIONING AND TOLERANCING PER ANSI Y14.5M, 1982.

DIM	MILLIMETERS		INCHES	
	MIN	MAX	MIN	MAX
A	9.40	10.16	0.370	0.400
B	6.10	6.60	0.240	0.260
C	3.94	4.45	0.155	0.175
D	0.38	0.51	0.015	0.020
F	1.02	1.78	0.040	0.070
G	2.54 BSC		0.100 BSC	
H	0.76	1.27	0.030	0.050
J	0.20	0.30	0.008	0.012
K	2.92	3.43	0.115	0.135
L	7.62 BSC		0.300 BSC	
M	— 10°		— 10°	
N	0.76	1.01	0.030	0.040

N, P, N-14, P2 SUFFIX
CASE 646-06
 Plastic Package
 ISSUE L

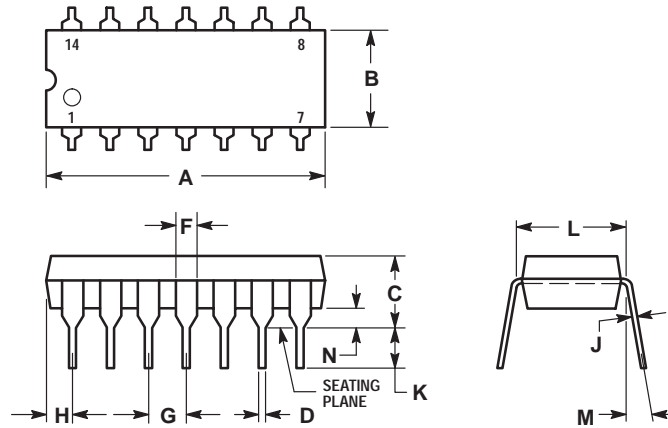
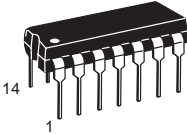

- NOTES:
1. LEADS WITHIN 0.13 (0.005) RADIUS OF TRUE POSITION AT SEATING PLANE AT MAXIMUM MATERIAL CONDITION.
 2. DIMENSION L TO CENTER OF LEADS WHEN FORMED PARALLEL.
 3. DIMENSION B DOES NOT INCLUDE MOLD FLASH.
 4. ROUNDED CORNERS OPTIONAL.

DIM	INCHES		MILLIMETERS	
	MIN	MAX	MIN	MAX
A	0.715	0.770	18.16	19.56
B	0.240	0.260	6.10	6.60
C	0.145	0.185	3.69	4.69
D	0.015	0.021	0.38	0.53
F	0.040	0.070	1.02	1.78
G	0.100 BSC		2.54 BSC	
H	0.052	0.095	1.32	2.41
J	0.008	0.015	0.20	0.38
K	0.115	0.135	2.92	3.43
L	0.300 BSC		7.62 BSC	
M	0° 10°		0° 10°	
N	0.015	0.039	0.39	1.01

DP2, N, P, PC SUFFIX
CASE 648-08
 Plastic Package
 ISSUE R

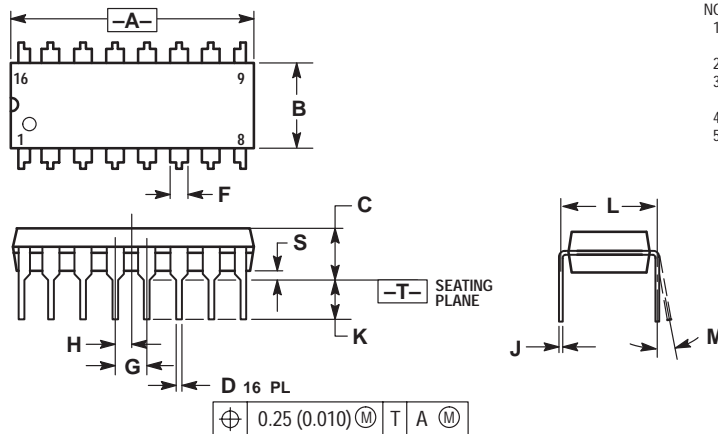
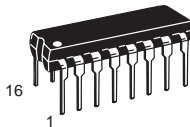

- NOTES:
1. DIMENSIONING AND TOLERANCING PER ANSI Y14.5M, 1982.
 2. CONTROLLING DIMENSION: INCH.
 3. DIMENSION L TO CENTER OF LEADS WHEN FORMED PARALLEL.
 4. DIMENSION B DOES NOT INCLUDE MOLD FLASH.
 5. ROUNDED CORNERS OPTIONAL.

DIM	INCHES		MILLIMETERS	
	MIN	MAX	MIN	MAX
A	0.740	0.770	18.80	19.55
B	0.250	0.270	6.35	6.85
C	0.145	0.175	3.69	4.44
D	0.015	0.021	0.39	0.53
F	0.040	0.70	1.02	1.77
G	0.100 BSC		2.54 BSC	
H	0.050 BSC		1.27 BSC	
J	0.008	0.015	0.21	0.38
K	0.110	0.130	2.80	3.30
L	0.295	0.305	7.50	7.74
M	0° 10°		0° 10°	
S	0.020	0.040	0.51	1.01

B, P, P2, V SUFFIX
CASE 648C-03
 Plastic Package
 (DIP-16)
 ISSUE C

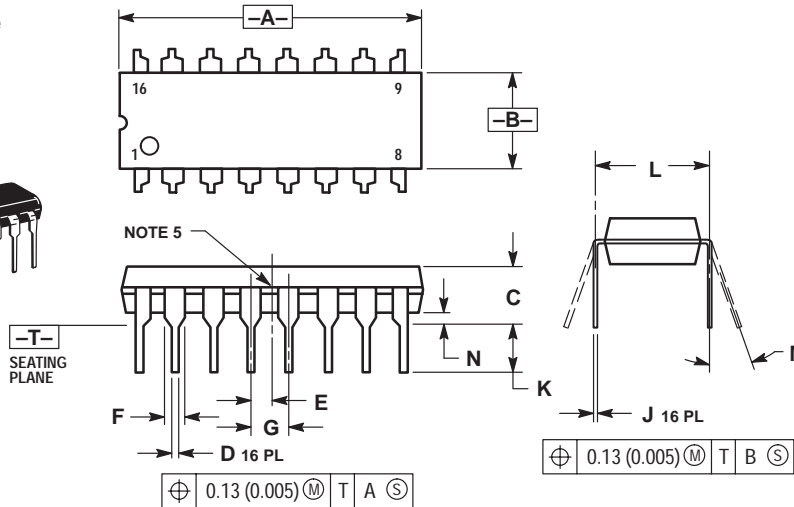
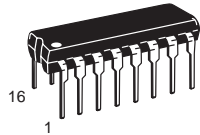

- NOTES:
1. DIMENSIONING AND TOLERANCING PER ANSI Y14.5M, 1982.
 2. CONTROLLING DIMENSION: INCH.
 3. DIMENSION L TO CENTER OF LEADS WHEN FORMED PARALLEL.
 4. DIMENSION B DOES NOT INCLUDE MOLD FLASH.
 5. INTERNAL LEAD CONNECTION BETWEEN 4 AND 5, 12 AND 13.

DIM	INCHES		MILLIMETERS	
	MIN	MAX	MIN	MAX
A	0.740	0.840	18.80	21.34
B	0.240	0.260	6.10	6.60
C	0.145	0.185	3.69	4.69
D	0.015	0.021	0.38	0.53
E	0.050 BSC			
F	0.040	0.70	1.02	1.78
G	0.100 BSC			
J	0.008	0.015	0.20	0.38
K	0.115	0.135	2.92	3.43
L	0.300 BSC			
M	0°	10°	0°	10°
N	0.015	0.040	0.39	1.01

P SUFFIX
CASE 648E-01
 Plastic Package
 (DIP-16)
 ISSUE O

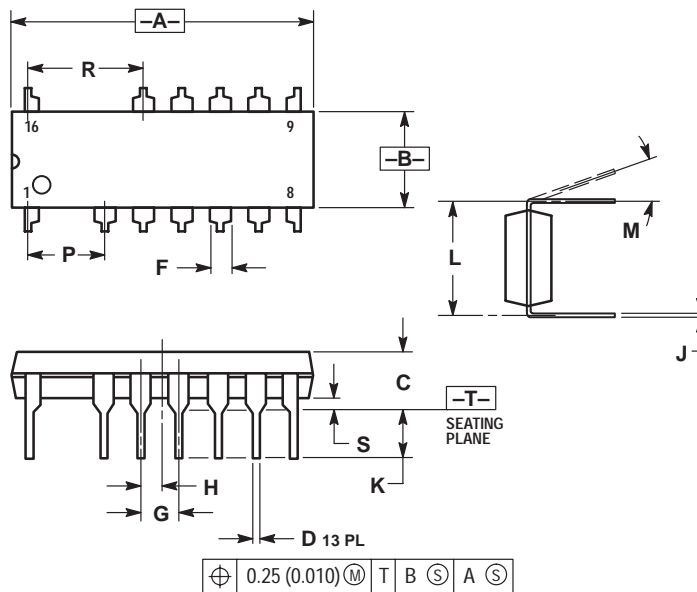
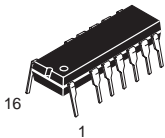

- NOTES:
1. DIMENSIONING AND TOLERANCING PER ANSI Y14.5M, 1982.
 2. CONTROLLING DIMENSION: INCH.
 3. DIMENSION L TO CENTER OF LEADS WHEN FORMED PARALLEL.
 4. DIMENSION A AND B DOES NOT INCLUDE MOLD PROTRUSION.
 5. MOLD FLASH OR PROTRUSIONS SHALL NOT EXCEED 0.25 (0.010).
 6. ROUNDED CORNER OPTIONAL.

DIM	INCHES		MILLIMETERS	
	MIN	MAX	MIN	MAX
A	0.740	0.760	18.80	19.30
B	0.245	0.260	6.23	6.60
C	0.145	0.175	3.69	4.44
D	0.015	0.021	0.39	0.53
F	0.050	0.070	1.27	1.77
G	0.100 BSC			
H	0.050 BSC			
J	0.008	0.015	0.21	0.38
K	0.120	0.140	3.05	3.55
L	0.295	0.305	7.50	7.74
M	0°	10°	0°	10°
P	0.200 BSC			
R	0.300 BSC			
S	0.015	0.035	0.39	0.88

P SUFFIX
CASE 649-03
 Plastic Package
 ISSUE D

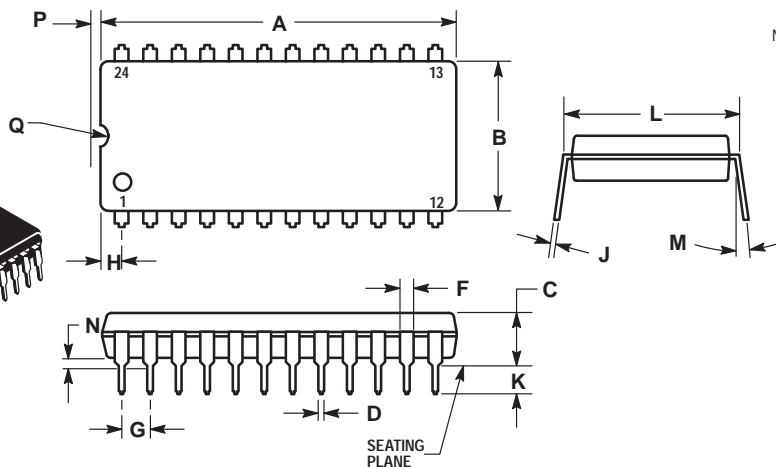
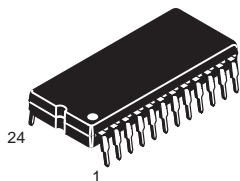

- NOTES:
1. LEADS WITHIN 0.13 (0.005) RADIUS OF TRUE POSITION AT SEATING PLANE AT MAXIMUM MATERIAL CONDITION.
 2. DIMENSION L TO CENTER OF LEADS WHEN FORMED PARALLEL.

DIM	MILLIMETERS		INCHES	
	MIN	MAX	MIN	MAX
A	31.50	32.13	1.240	1.265
B	13.21	13.72	0.520	0.540
C	4.70	5.21	0.185	0.205
D	0.38	0.51	0.015	0.020
F	1.02	1.52	0.040	0.060
G	2.54 BSC			
H	1.65	2.16	0.065	0.085
J	0.20	0.30	0.008	0.012
K	2.92	3.43	0.115	0.135
L	14.99	15.49	0.590	0.610
M	---	10	---	10°
N	0.51	1.02	0.020	0.040
P	0.13	0.38	0.005	0.015
Q	0.51	0.76	0.020	0.030

A, B, N, P SUFFIX
CASE 707-02
 Plastic Package
 ISSUE C

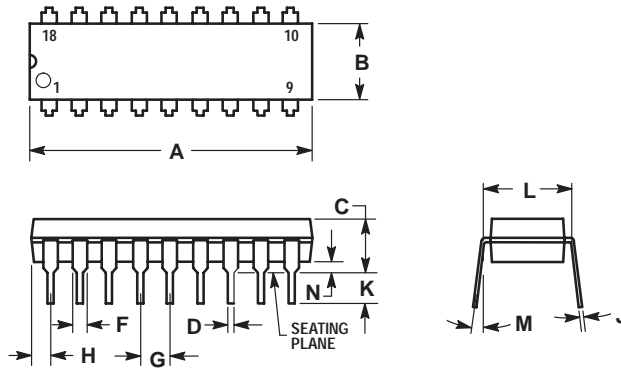
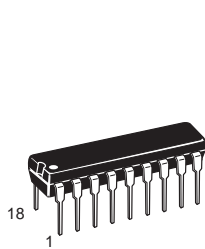

- NOTES:
1. POSITIONAL TOLERANCE OF LEADS (D), SHALL BE WITHIN 0.25 (0.010) AT MAXIMUM MATERIAL CONDITION, IN RELATION TO SEATING PLANE AND EACH OTHER.
 2. DIMENSION L TO CENTER OF LEADS WHEN FORMED PARALLEL.
 3. DIMENSION B DOES NOT INCLUDE MOLD FLASH.

DIM	MILLIMETERS		INCHES	
	MIN	MAX	MIN	MAX
A	22.22	23.24	0.875	0.915
B	6.10	6.60	0.240	0.260
C	3.56	4.57	0.140	0.180
D	0.36	0.56	0.014	0.022
F	1.27	1.78	0.050	0.070
G	2.54 BSC		0.100 BSC	
H	1.02	1.52	0.040	0.060
J	0.20	0.30	0.008	0.012
K	2.92	3.43	0.115	0.135
L	7.62 BSC		0.300 BSC	
M	0°	15°	0°	15°
N	0.51	1.02	0.020	0.040

P SUFFIX
CASE 710-02
 Plastic Package
 ISSUE B

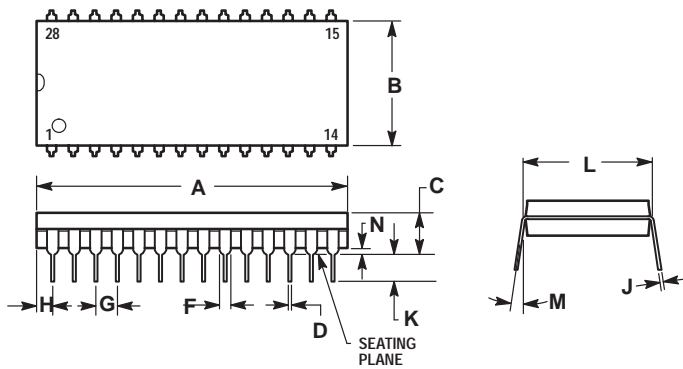
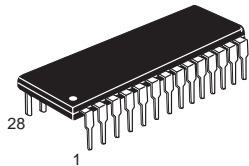

- NOTES:
1. POSITIONAL TOLERANCE OF LEADS (D), SHALL BE WITHIN 0.25 (0.010) AT MAXIMUM MATERIAL CONDITION, IN RELATION TO SEATING PLANE AND EACH OTHER.
 2. DIMENSION L TO CENTER OF LEADS WHEN FORMED PARALLEL.
 3. DIMENSION B DOES NOT INCLUDE MOLD FLASH.

DIM	MILLIMETERS		INCHES	
	MIN	MAX	MIN	MAX
A	36.45	37.21	1.435	1.465
B	13.72	14.22	0.540	0.560
C	3.94	5.08	0.155	0.200
D	0.36	0.56	0.014	0.022
F	1.02	1.52	0.040	0.060
G	2.54 BSC		0.100 BSC	
H	1.65	2.16	0.065	0.085
J	0.20	0.38	0.008	0.015
K	2.92	3.43	0.115	0.135
L	15.24 BSC		0.600 BSC	
M	0°	15°	0°	15°
N	0.51	1.02	0.020	0.040

P SUFFIX
CASE 711-03
 Plastic Package
 ISSUE C

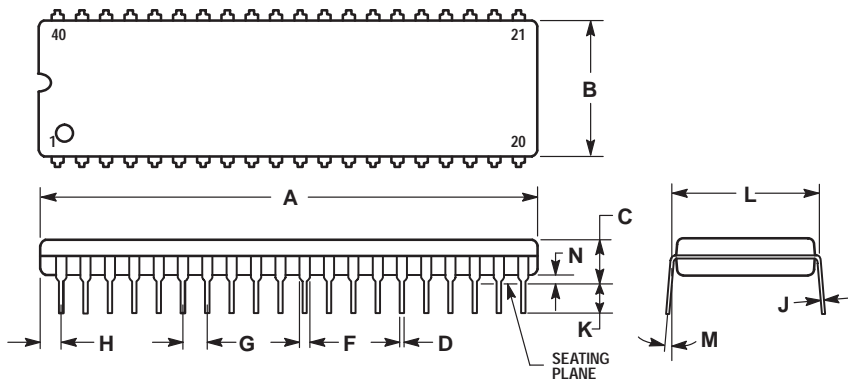
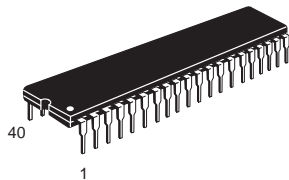

- NOTES:
1. POSITIONAL TOLERANCE OF LEADS (D), SHALL BE WITHIN 0.25 (0.010) AT MAXIMUM MATERIAL CONDITION, IN RELATION TO SEATING PLANE AND EACH OTHER.
 2. DIMENSION L TO CENTER OF LEADS WHEN FORMED PARALLEL.
 3. DIMENSION B DOES NOT INCLUDE MOLD FLASH.

DIM	MILLIMETERS		INCHES	
	MIN	MAX	MIN	MAX
A	51.69	52.45	2.035	2.065
B	13.72	14.22	0.540	0.560
C	3.94	5.08	0.155	0.200
D	0.36	0.56	0.014	0.022
F	1.02	1.52	0.040	0.060
G	2.54 BSC		0.100 BSC	
H	1.65	2.16	0.065	0.085
J	0.20	0.38	0.008	0.015
K	2.92	3.43	0.115	0.135
L	15.24 BSC		0.600 BSC	
M	0°	15°	0°	15°
N	0.51	1.02	0.020	0.040

F, P, P-3 SUFFIX
CASE 724-03
 Plastic Package
 (NDIP-24)
 ISSUE D

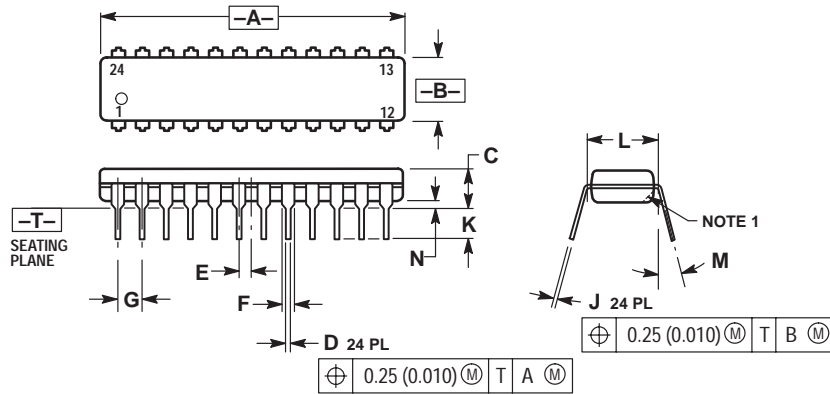
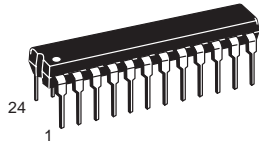

- NOTES:
1. CHAMFERED CONTOUR OPTIONAL.
 2. DIMENSION L TO CENTER OF LEADS WHEN FORMED PARALLEL.
 3. DIMENSIONING AND TOLERANCING PER ANSI Y14.5M, 1982.
 4. CONTROLLING DIMENSION: INCH.

DIM	INCHES		MILLIMETERS	
	MIN	MAX	MIN	MAX
A	1.230	1.265	31.25	32.13
B	0.250	0.270	6.35	6.85
C	0.145	0.175	3.69	4.44
D	0.015	0.020	0.38	0.51
E	0.050 BSC		1.27 BSC	
F	0.040	0.060	1.02	1.52
G	0.100 BSC		2.54 BSC	
J	0.007	0.012	0.18	0.30
K	0.110	0.140	2.80	3.55
L	0.300 BSC		7.62 BSC	
M	0°	15°	0°	15°
N	0.020	0.040	0.51	1.01

H, P, DP SUFFIX
CASE 738-03
 Plastic Package
 ISSUE E

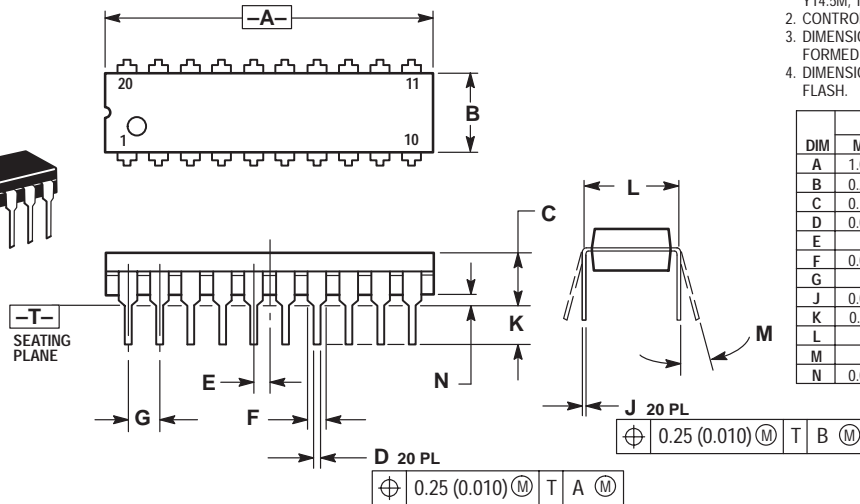
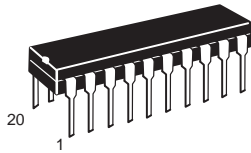

- NOTES:
1. DIMENSIONING AND TOLERANCING PER ANSI Y14.5M, 1982.
 2. CONTROLLING DIMENSION: INCH.
 3. DIMENSION L TO CENTER OF LEAD WHEN FORMED PARALLEL.
 4. DIMENSION B DOES NOT INCLUDE MOLD FLASH.

DIM	INCHES		MILLIMETERS	
	MIN	MAX	MIN	MAX
A	1.010	1.070	25.66	27.17
B	0.240	0.260	6.10	6.60
C	0.150	0.180	3.81	4.57
D	0.015	0.022	0.39	0.55
E	0.050 BSC		1.27 BSC	
F	0.050	0.070	1.27	1.77
G	0.100 BSC		2.54 BSC	
J	0.008	0.015	0.21	0.38
K	0.110	0.140	2.80	3.55
L	0.300 BSC		7.62 BSC	
M	0°	15°	0°	15°
N	0.020	0.040	0.51	1.01

D, D1, D2 SUFFIX
CASE 751-05
 Plastic Package
 (SO-8, SOP-8)
 ISSUE R

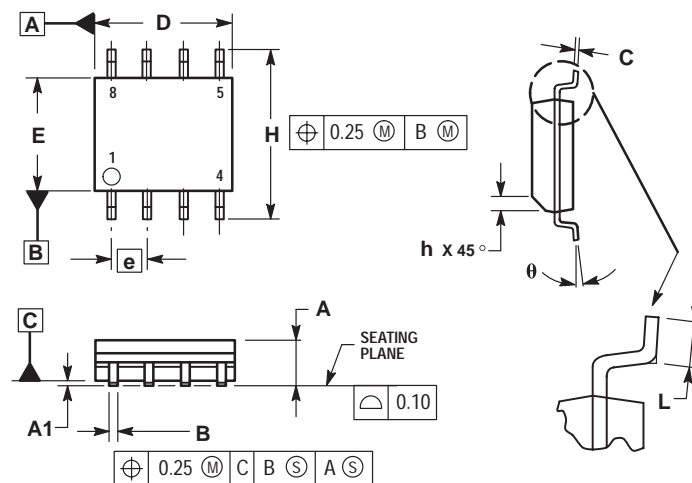

- NOTES:
1. DIMENSIONING AND TOLERANCING PER ASME Y14.5M, 1994.
 2. DIMENSIONS ARE IN MILLIMETERS.
 3. DIMENSION D AND E DO NOT INCLUDE MOLD PROTRUSION.
 4. MAXIMUM MOLD PROTRUSION 0.15 PER SIDE.
 5. DIMENSION B DOES NOT INCLUDE MOLD PROTRUSION. ALLOWABLE DAMBAR PROTRUSION SHALL BE 0.127 TOTAL IN EXCESS OF THE B DIMENSION AT MAXIMUM MATERIAL CONDITION.

DIM	MILLIMETERS	
	MIN	MAX
A	1.35	1.75
A1	0.10	0.25
B	0.35	0.49
C	0.18	0.25
D	4.80	5.00
E	3.80	4.00
e	1.27 BSC	
H	5.80	6.20
h	0.25	0.50
L	0.40	1.25
θ	0°	7°

D SUFFIX
CASE 751A-03
 Plastic Package
 (SO-14)
 ISSUE F

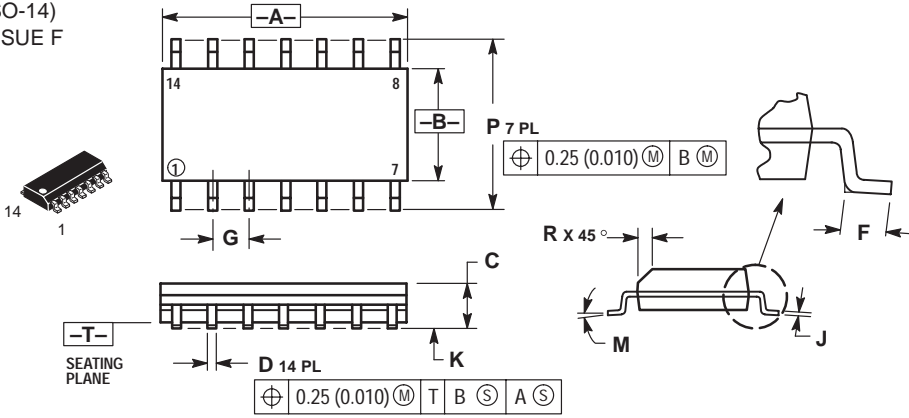

- NOTES:
1. DIMENSIONING AND TOLERANCING PER ANSI Y14.5M, 1982.
 2. CONTROLLING DIMENSION: MILLIMETER.
 3. DIMENSIONS A AND B DO NOT INCLUDE MOLD PROTRUSION.
 4. MAXIMUM MOLD PROTRUSION 0.15 (0.006) PER SIDE.
 5. DIMENSION D DOES NOT INCLUDE DAMBAR PROTRUSION. ALLOWABLE DAMBAR PROTRUSION SHALL BE 0.127 (0.005) TOTAL IN EXCESS OF THE D DIMENSION AT MAXIMUM MATERIAL CONDITION.

DIM	MILLIMETERS		INCHES	
	MIN	MAX	MIN	MAX
A	8.55	8.75	0.337	0.344
B	3.80	4.00	0.150	0.157
C	1.35	1.75	0.054	0.068
D	0.35	0.49	0.014	0.019
F	0.40	1.25	0.016	0.049
G	1.27 BSC		0.050 BSC	
J	0.19	0.25	0.008	0.009
K	0.10	0.25	0.004	0.009
M	0°	7°	0°	7°
P	5.80	6.20	0.228	0.244
R	0.25	0.50	0.010	0.019

D SUFFIX
CASE 751B-05
 Plastic Package
 (SO-16)
 ISSUE J

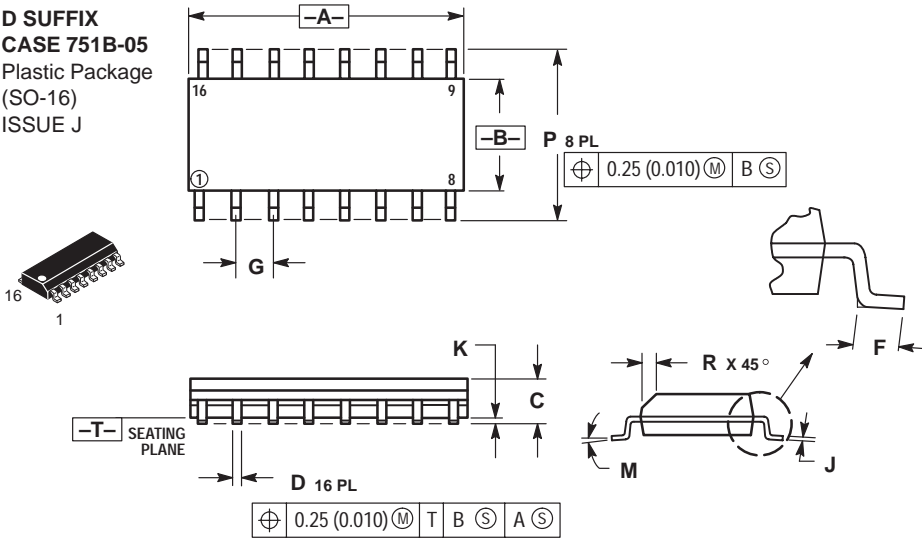

- NOTES:
1. DIMENSIONING AND TOLERANCING PER ANSI Y14.5M, 1982.
 2. CONTROLLING DIMENSION: MILLIMETER.
 3. DIMENSIONS A AND B DO NOT INCLUDE MOLD PROTRUSION.
 4. MAXIMUM MOLD PROTRUSION 0.15 (0.006) PER SIDE.
 5. DIMENSION D DOES NOT INCLUDE DAMBAR PROTRUSION. ALLOWABLE DAMBAR PROTRUSION SHALL BE 0.127 (0.005) TOTAL IN EXCESS OF THE D DIMENSION AT MAXIMUM MATERIAL CONDITION.

DIM	MILLIMETERS		INCHES	
	MIN	MAX	MIN	MAX
A	9.80	10.00	0.386	0.393
B	3.80	4.00	0.150	0.157
C	1.35	1.75	0.054	0.068
D	0.35	0.49	0.014	0.019
F	0.40	1.25	0.016	0.049
G	1.27 BSC		0.050 BSC	
J	0.19	0.25	0.008	0.009
K	0.10	0.25	0.004	0.009
M	0°	7°	0°	7°
P	5.80	6.20	0.229	0.244
R	0.25	0.50	0.010	0.019

DW, FP SUFFIX
CASE 751D-04
 Plastic Package
 (SO-20L, SO-20)
 ISSUE E

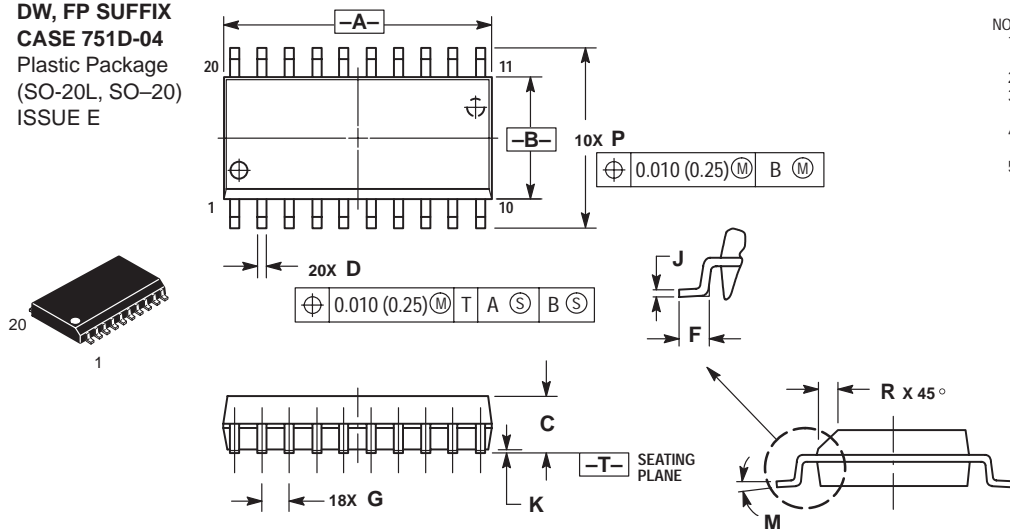

- NOTES:
1. DIMENSIONING AND TOLERANCING PER ANSI Y14.5M, 1982.
 2. CONTROLLING DIMENSION: MILLIMETER.
 3. DIMENSIONS A AND B DO NOT INCLUDE MOLD PROTRUSION.
 4. MAXIMUM MOLD PROTRUSION 0.150 (0.006) PER SIDE.
 5. DIMENSION D DOES NOT INCLUDE DAMBAR PROTRUSION. ALLOWABLE DAMBAR PROTRUSION SHALL BE 0.13 (0.005) TOTAL IN EXCESS OF D DIMENSION AT MAXIMUM MATERIAL CONDITION.

DIM	MILLIMETERS		INCHES	
	MIN	MAX	MIN	MAX
A	12.65	12.95	0.499	0.510
B	7.40	7.60	0.292	0.299
C	2.35	2.65	0.093	0.104
D	0.35	0.49	0.014	0.019
F	0.50	0.90	0.020	0.035
G	1.27 BSC		0.050 BSC	
J	0.25	0.32	0.010	0.012
K	0.10	0.25	0.004	0.009
M	0°	7°	0°	7°
P	10.05	10.55	0.395	0.415
R	0.25	0.75	0.010	0.029

DW SUFFIX
CASE 751E-04
 Plastic Package
 (SO-24L,
 SOP (16+4+4)L)
 ISSUE E

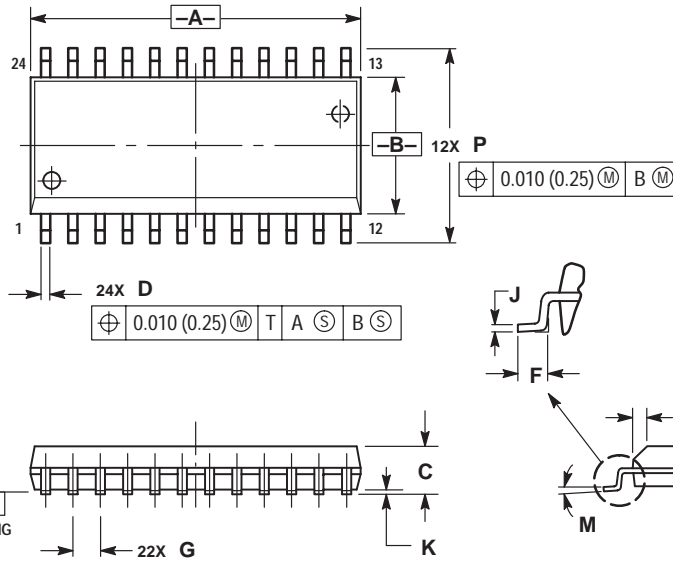
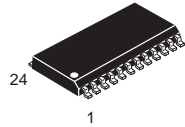

NOTES:

1. DIMENSIONING AND TOLERANCING PER ANSI Y14.5M, 1982.
2. CONTROLLING DIMENSION: MILLIMETER.
3. DIMENSIONS A AND B DO NOT INCLUDE MOLD PROTRUSION.
4. MAXIMUM MOLD PROTRUSION 0.15 (0.006) PER SIDE.
5. DIMENSION D DOES NOT INCLUDE DAMBAR PROTRUSION. ALLOWABLE DAMBAR PROTRUSION SHALL BE 0.13 (0.005) TOTAL IN EXCESS OF D DIMENSION AT MAXIMUM MATERIAL CONDITION.

DIM	MILLIMETERS		INCHES	
	MIN	MAX	MIN	MAX
A	15.25	15.54	0.601	0.612
B	7.40	7.60	0.292	0.299
C	2.35	2.65	0.093	0.104
D	0.35	0.49	0.014	0.019
F	0.41	0.90	0.016	0.035
G	1.27 BSC		0.050 BSC	
J	0.23	0.32	0.009	0.013
K	0.13	0.29	0.005	0.011
M	0°	8°	0°	8°
P	10.05	10.55	0.395	0.415
R	0.25	0.75	0.010	0.029

DW SUFFIX
CASE 751F-04
 Plastic Package
 (SO-28L, SOIC-28)
 ISSUE E

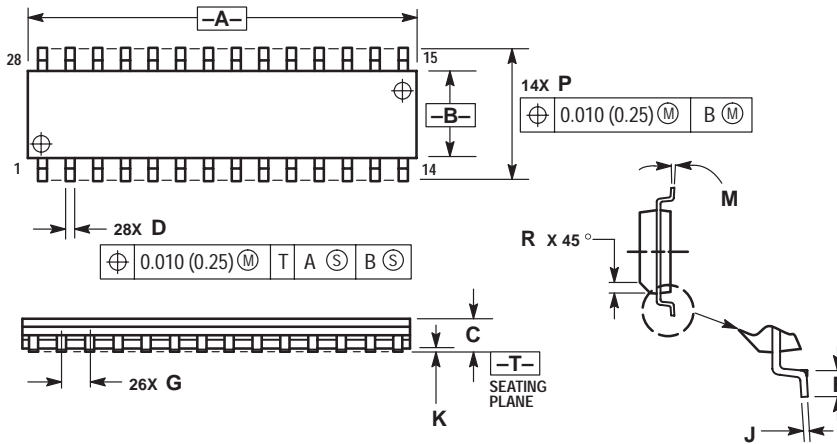
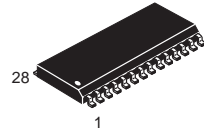

NOTES:

1. DIMENSIONING AND TOLERANCING PER ANSI Y14.5M, 1982.
2. CONTROLLING DIMENSION: MILLIMETER.
3. DIMENSION A AND B DO NOT INCLUDE MOLD PROTRUSION.
4. MAXIMUM MOLD PROTRUSION 0.15 (0.006) PER SIDE.
5. DIMENSION D DOES NOT INCLUDE DAMBAR PROTRUSION. ALLOWABLE DAMBAR PROTRUSION SHALL BE 0.13 (0.005) TOTAL IN EXCESS OF D DIMENSION AT MAXIMUM MATERIAL CONDITION.

DIM	MILLIMETERS		INCHES	
	MIN	MAX	MIN	MAX
A	17.80	18.05	0.701	0.711
B	7.40	7.60	0.292	0.299
C	2.35	2.65	0.093	0.104
D	0.35	0.49	0.014	0.019
F	0.41	0.90	0.016	0.035
G	1.27 BSC		0.050 BSC	
J	0.23	0.32	0.009	0.013
K	0.13	0.29	0.005	0.011
M	0°	8°	0°	8°
P	10.01	10.55	0.395	0.415
R	0.25	0.75	0.010	0.029

DW SUFFIX
CASE 751G-02
 Plastic Package
 (SO-16L, SOP-16L,
 SOP-8+8L)
 ISSUE A

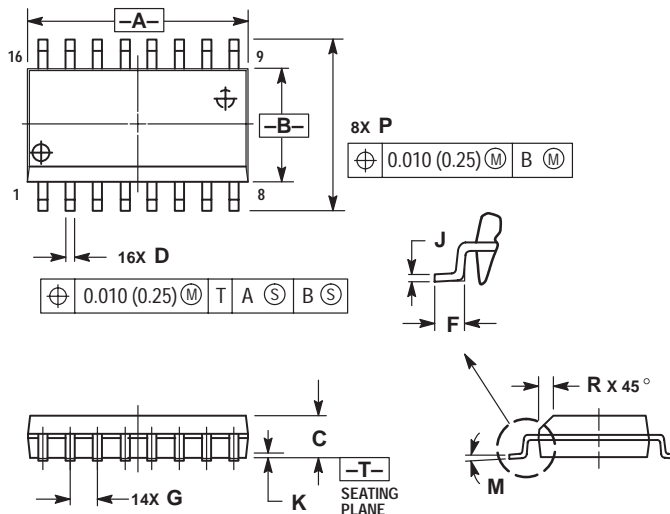
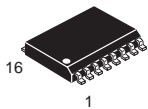

NOTES:

1. DIMENSIONING AND TOLERANCING PER ANSI Y14.5M, 1982.
2. CONTROLLING DIMENSION: MILLIMETER.
3. DIMENSIONS A AND B DO NOT INCLUDE MOLD PROTRUSION.
4. MAXIMUM MOLD PROTRUSION 0.15 (0.006) PER SIDE.
5. DIMENSION D DOES NOT INCLUDE DAMBAR PROTRUSION. ALLOWABLE DAMBAR PROTRUSION SHALL BE 0.13 (0.005) TOTAL IN EXCESS OF D DIMENSION AT MAXIMUM MATERIAL CONDITION.

DIM	MILLIMETERS		INCHES	
	MIN	MAX	MIN	MAX
A	10.15	10.45	0.400	0.411
B	7.40	7.60	0.292	0.299
C	2.35	2.65	0.093	0.104
D	0.35	0.49	0.014	0.019
F	0.50	0.90	0.020	0.035
G	1.27 BSC		0.050 BSC	
J	0.25	0.32	0.010	0.012
K	0.10	0.25	0.004	0.009
M	0°	7°	0°	7°
P	10.05	10.55	0.395	0.415
R	0.25	0.75	0.010	0.029

D SUFFIX
CASE 751K-01
 Plastic Package
 (SO-16)
 ISSUE O

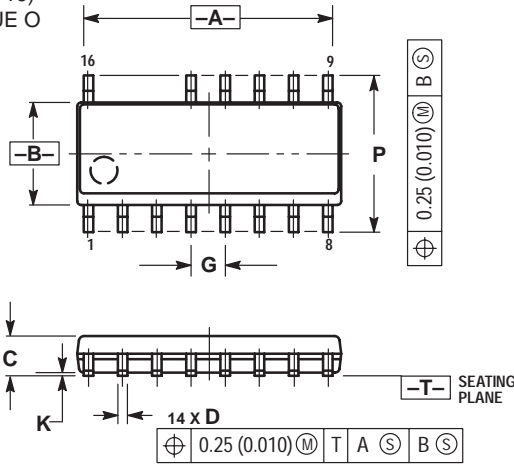
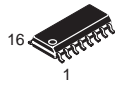

NOTES:

1. DIMENSIONING AND TOLERANCING PER ANSI Y14.5M, 1982.
2. CONTROLLING DIMENSION: MILLIMETER.
3. DIMENSIONS A AND B DO NOT INCLUDE MOLD PROTRUSION.
4. MAXIMUM MOLD PROTRUSION 0.15 (0.006) PER SIDE.
5. DIMENSION D DOES NOT INCLUDE DAMBAR PROTRUSION. ALLOWABLE DAMBAR PROTRUSION SHALL BE 0.127 (0.005) TOTAL IN EXCESS OF THE D DIMENSION AT MAXIMUM MATERIAL CONDITION.

DIM	MILLIMETERS		INCHES	
	MIN	MAX	MIN	MAX
A	9.80	10.00	0.368	0.393
B	3.80	4.00	0.150	0.157
C	1.35	1.75	0.054	0.068
D	0.35	0.49	0.014	0.019
F	0.40	1.25	0.016	0.049
G	1.27 BSC		0.050 BSC	
J	0.19	0.25	0.008	0.009
K	0.10	0.25	0.004	0.009
M	0°	7°	0°	7°
P	5.80	6.20	0.229	0.244
R	0.25	0.50	0.010	0.019

DW SUFFIX
CASE 751N-01
 Plastic Package
 (SOP-16L)
 ISSUE O

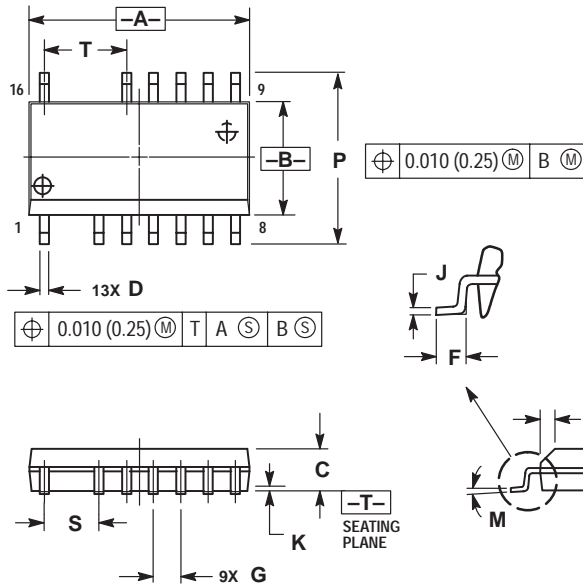
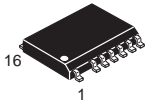

NOTES:

1. DIMENSIONING AND TOLERANCING PER ANSI Y14.5M, 1982.
2. CONTROLLING DIMENSION: MILLIMETER.
3. DIMENSIONS A AND B DO NOT INCLUDE MOLD PROTRUSION.
4. MAXIMUM MOLD PROTRUSION 0.15 (0.006) PER SIDE.
5. DIMENSION D DOES NOT INCLUDE DAMBAR PROTRUSION. ALLOWABLE DAMBAR PROTRUSION SHALL BE 0.13 (0.005) TOTAL IN EXCESS OF D DIMENSION AT MAXIMUM MATERIAL CONDITION.

DIM	MILLIMETERS		INCHES	
	MIN	MAX	MIN	MAX
A	10.15	10.45	0.400	0.411
B	7.40	7.60	0.292	0.299
C	2.35	2.65	0.093	0.104
D	0.35	0.49	0.014	0.019
F	0.50	0.90	0.020	0.035
G	1.27 BSC		0.050 BSC	
J	0.25	0.32	0.010	0.012
K	0.10	0.25	0.004	0.009
M	0°	7°	0°	7°
P	10.05	10.55	0.395	0.415
R	0.25	0.75	0.010	0.029
S	2.54 BSC		0.100 BSC	
T	3.81 BSC		0.150 BSC	

CASE 762-01
 Plastic Medium Power Package
 (SIP-9)
 ISSUE C

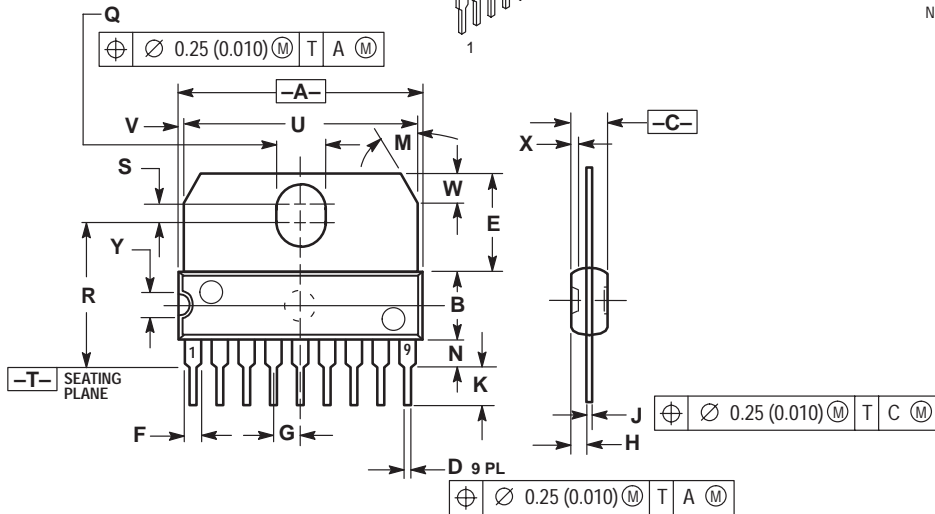
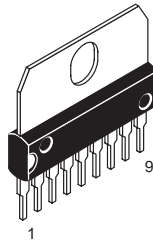

- NOTES:
 1. DIMENSIONING AND TOLERANCING PER ANSI Y14.5, 1982.
 2. CONTROLLING DIMENSION: MILLIMETER.

DIM	MILLIMETERS		INCHES	
	MIN	MAX	MIN	MAX
A	22.40	23.00	0.873	0.897
B	6.40	6.60	0.252	0.260
C	3.45	3.65	0.135	1.143
D	0.40	0.55	0.015	0.021
E	9.35	9.60	0.368	0.377
F	1.40	1.60	0.055	0.062
G	2.54 BSC		0.100 BSC	
H	1.51	1.71	0.059	0.067
J	0.360	0.400	0.014	0.015
K	3.95	4.20	0.155	0.165
M	30° BSC		30° BSC	
N	2.50	2.70	0.099	0.106
Q	3.15	3.45	0.124	0.135
R	13.60	13.90	0.535	0.547
S	1.65	1.95	0.064	0.076
U	22.00	22.20	0.866	0.874
V	0.55	0.75	0.021	0.029
W	2.89 BSC		0.113 BSC	
X	0.65	0.75	0.025	0.029
Y	2.70	2.80	0.106	0.110

FN SUFFIX
CASE 775-02
 Plastic Package
 (PLCC-20)
 ISSUE C

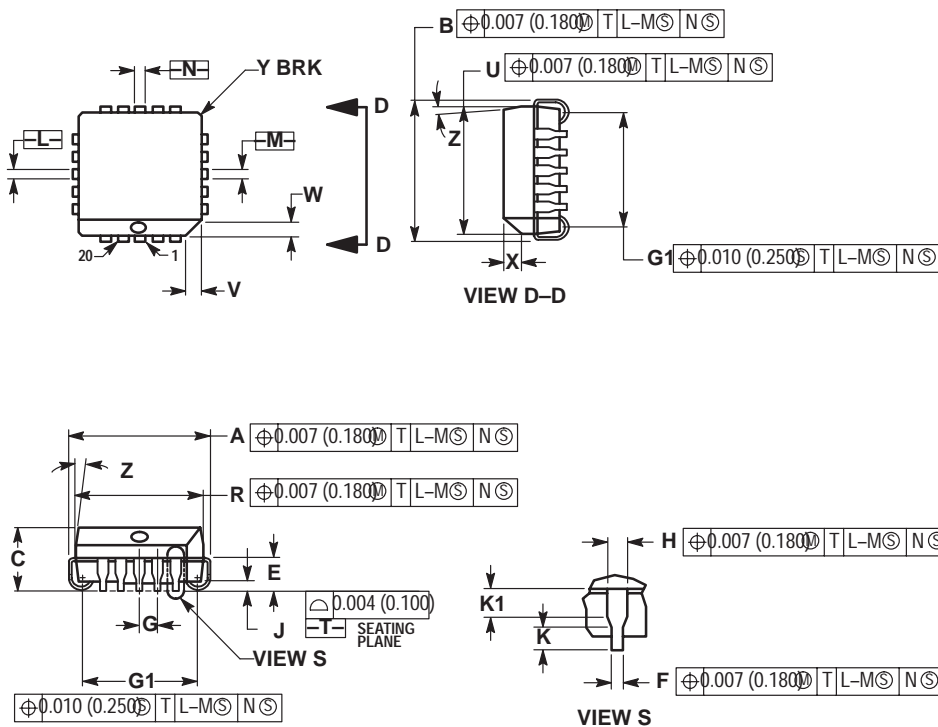
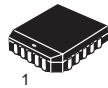

- NOTES:
 1. DATUMS -L-, -M-, AND -N- DETERMINED WHERE TOP OF LEAD SHOULDER EXITS PLASTIC BODY AT MOLD PARTING LINE.
 2. DIMENSION G1, TRUE POSITION TO BE MEASURED AT DATUM -T-, SEATING PLANE.
 3. DIMENSIONS R AND U DO NOT INCLUDE MOLD FLASH. ALLOWABLE MOLD FLASH IS 0.010 (0.250) PER SIDE.
 4. DIMENSIONING AND TOLERANCING PER ANSI Y14.5M, 1982.
 5. CONTROLLING DIMENSION: INCH.
 6. THE PACKAGE TOP MAY BE SMALLER THAN THE PACKAGE BOTTOM BY UP TO 0.012 (0.300). DIMENSIONS R AND U ARE DETERMINED AT THE OUTERMOST EXTREMES OF THE PLASTIC BODY EXCLUSIVE OF MOLD FLASH, TIE BAR BURRS, GATE BURRS AND INTERLEAD FLASH, BUT INCLUDING ANY MISMATCH BETWEEN THE TOP AND BOTTOM OF THE PLASTIC BODY.
 7. DIMENSION H DOES NOT INCLUDE DAMBAR PROTRUSION OR INTRUSION. THE DAMBAR PROTRUSION(S) SHALL NOT CAUSE THE H DIMENSION TO BE GREATER THAN 0.037 (0.940). THE DAMBAR INTRUSION(S) SHALL NOT CAUSE THE H DIMENSION TO BE SMALLER THAN 0.025 (0.635).

DIM	INCHES		MILLIMETERS	
	MIN	MAX	MIN	MAX
A	0.385	0.395	9.78	10.03
B	0.385	0.395	9.78	10.03
C	0.165	0.180	4.20	4.57
E	0.090	0.110	2.29	2.79
F	0.013	0.019	0.33	0.48
G	0.050 BSC		1.27 BSC	
H	0.026	0.032	0.66	0.81
J	0.020	---	0.51	---
K	0.025	---	0.64	---
R	0.350	0.356	8.89	9.04
U	0.350	0.356	8.89	9.04
V	0.042	0.048	1.07	1.21
W	0.042	0.048	1.07	1.21
X	0.042	0.056	1.07	1.42
Y	---	0.020	---	0.50
Z	2°	10°	---	10°
G1	0.310	0.330	7.88	8.38
K1	0.040	---	1.02	---

FN SUFFIX
CASE 776-02
 Plastic Package
 (PLCC-28)
 ISSUE D

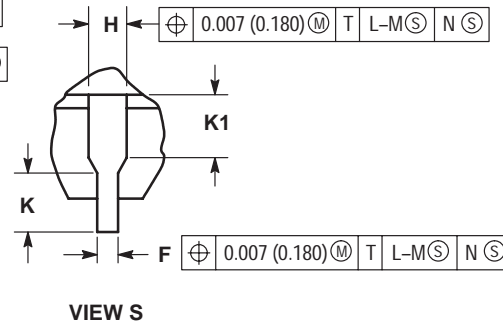
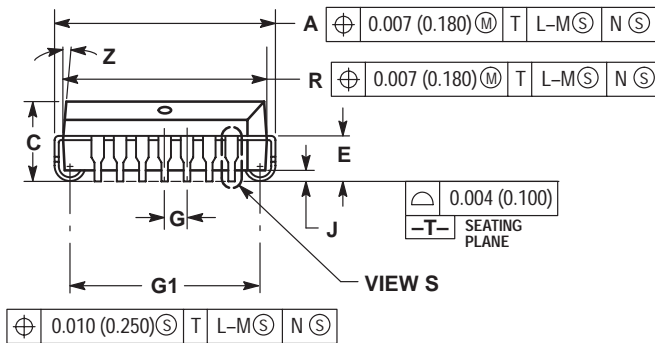
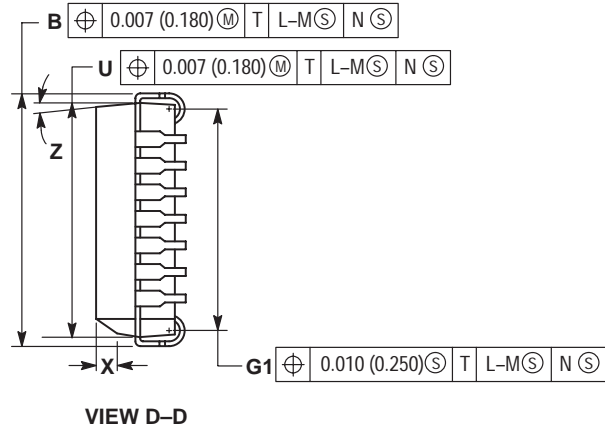
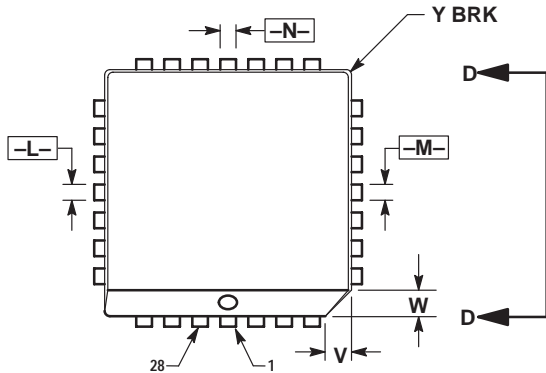
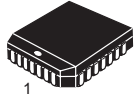

NOTES:

- DATUMS -L-, -M-, AND -N- DETERMINED WHERE TOP OF LEAD SHOULDER EXITS PLASTIC BODY AT MOLD PARTING LINE.
- DIMENSION G1, TRUE POSITION TO BE MEASURED AT DATUM -T-, SEATING PLANE.
- DIMENSIONS R AND U DO NOT INCLUDE MOLD FLASH. ALLOWABLE MOLD FLASH IS 0.010 (0.250) PER SIDE.
- DIMENSIONING AND TOLERANCING PER ANSI Y14.5M, 1982.
- CONTROLLING DIMENSION: INCH.
- THE PACKAGE TOP MAY BE SMALLER THAN THE PACKAGE BOTTOM BY UP TO 0.012 (0.300). DIMENSIONS R AND U ARE DETERMINED AT THE OUTERMOST EXTREMES OF THE PLASTIC BODY EXCLUSIVE OF MOLD FLASH, TIE BAR BURRS, GATE BURRS AND INTERLEAD FLASH, BUT INCLUDING ANY MISMATCH BETWEEN THE TOP AND BOTTOM OF THE PLASTIC BODY.
- DIMENSION H DOES NOT INCLUDE DAMBAR PROTRUSION OR INTRUSION. THE DAMBAR PROTRUSION(S) SHALL NOT CAUSE THE H DIMENSION TO BE GREATER THAN 0.037 (0.940). THE DAMBAR INTRUSION(S) SHALL NOT CAUSE THE H DIMENSION TO BE SMALLER THAN 0.025 (0.635).

DIM	INCHES		MILLIMETERS	
	MIN	MAX	MIN	MAX
A	0.485	0.495	12.32	12.57
B	0.485	0.495	12.32	12.57
C	0.165	0.180	4.20	4.57
E	0.090	0.110	2.29	2.79
F	0.013	0.019	0.33	0.48
G	0.050 BSC		1.27 BSC	
H	0.026	0.032	0.66	0.81
J	0.020	---	0.51	---
K	0.025	---	0.64	---
R	0.450	0.456	11.43	11.58
U	0.450	0.456	11.43	11.58
V	0.042	0.048	1.07	1.21
W	0.042	0.048	1.07	1.21
X	0.042	0.056	1.07	1.42
Y	---	0.020	---	0.50
Z	2°	10°	2°	10°
G1	0.410	0.430	10.42	10.92
K1	0.040	---	1.02	---

FN SUFFIX
CASE 777-02
 Plastic Package
 (PLCC)
 ISSUE C

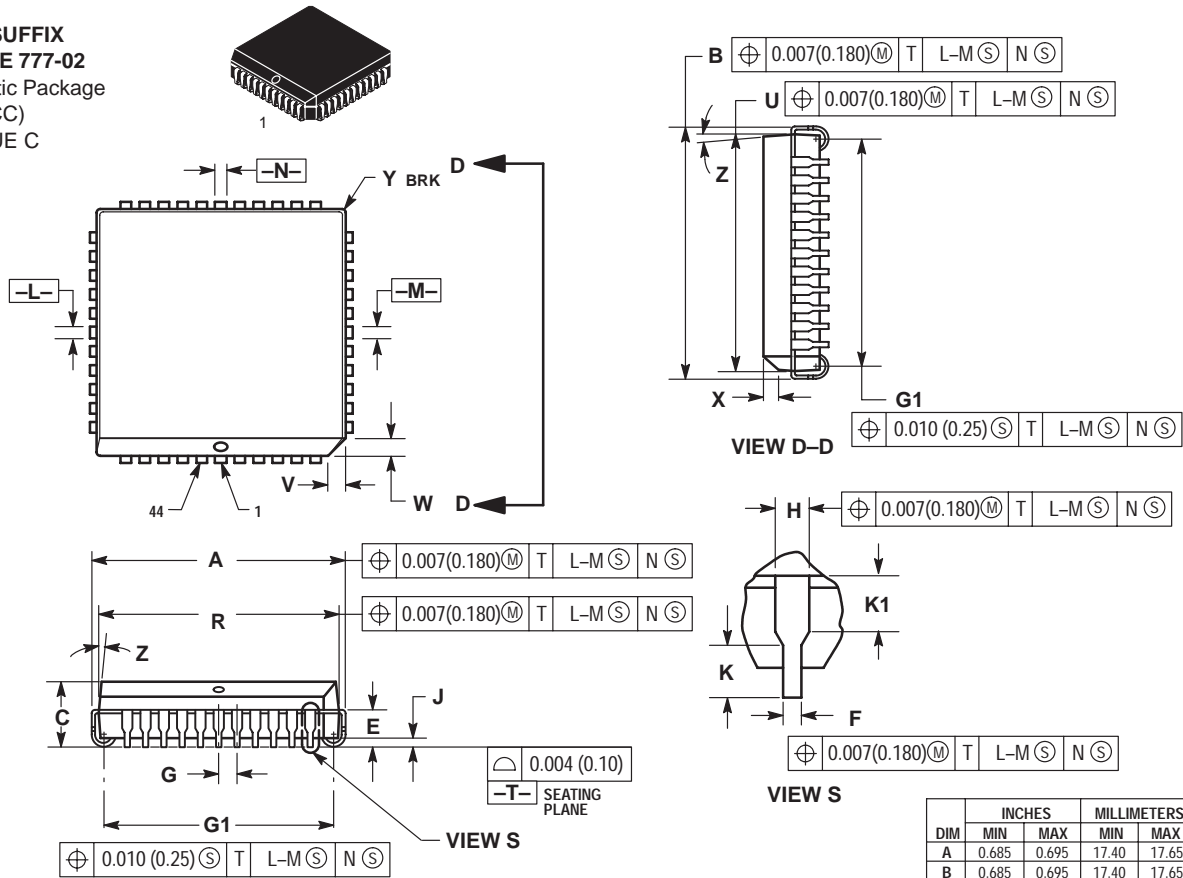

NOTES:

- DATUMS -L-, -M-, AND -N- ARE DETERMINED WHERE TOP OF LEAD SHOULDER EXITS PLASTIC BODY AT MOLD PARTING LINE.
- DIMENSION G1, TRUE POSITION TO BE MEASURED AT DATUM -T-, SEATING PLANE.
- DIMENSIONS R AND U DO NOT INCLUDE MOLD FLASH. ALLOWABLE MOLD FLASH IS 0.010 (0.25) PER SIDE.
- DIMENSIONING AND TOLERANCING PER ANSI Y14.5M, 1982.
- CONTROLLING DIMENSION: INCH.

- THE PACKAGE TOP MAY BE SMALLER THAN THE PACKAGE BOTTOM BY UP TO 0.012 (0.300). DIMENSIONS R AND U ARE DETERMINED AT THE OUTERMOST EXTREMES OF THE PLASTIC BODY EXCLUSIVE OF MOLD FLASH, TIE BAR BURRS, GATE BURRS AND INTERLEAD FLASH, BUT INCLUDING ANY MISMATCH BETWEEN THE TOP AND BOTTOM OF THE PLASTIC BODY.
- DIMENSION H DOES NOT INCLUDE DAMBAR PROTRUSION OR INTRUSION. THE DAMBAR PROTRUSION(S) SHALL NOT CAUSE THE H DIMENSION TO BE GREATER THAN 0.037 (0.940). THE DAMBAR INTRUSION(S) SHALL NOT CAUSE THE H DIMENSION TO BE SMALLER THAN 0.025 (0.635).

DIM	INCHES		MILLIMETERS	
	MIN	MAX	MIN	MAX
A	0.685	0.695	17.40	17.65
B	0.685	0.695	17.40	17.65
C	0.165	0.180	4.20	4.57
E	0.090	0.110	2.29	2.79
F	0.013	0.019	0.33	0.48
G	0.050 BSC		1.27 BSC	
H	0.026	0.032	0.66	0.81
J	0.020	---	0.51	---
K	0.025	---	0.64	---
R	0.650	0.656	16.51	16.66
U	0.650	0.656	16.51	16.66
V	0.042	0.048	1.07	1.21
W	0.042	0.048	1.07	1.21
X	0.042	0.056	1.07	1.42
Y	---	0.020	---	0.50
Z	2°	10°	2°	10°
G1	0.610	0.630	15.50	16.00
K1	0.040	---	1.02	---

M SUFFIX
CASE 803C
PRELIMINARY
 Plastic Package

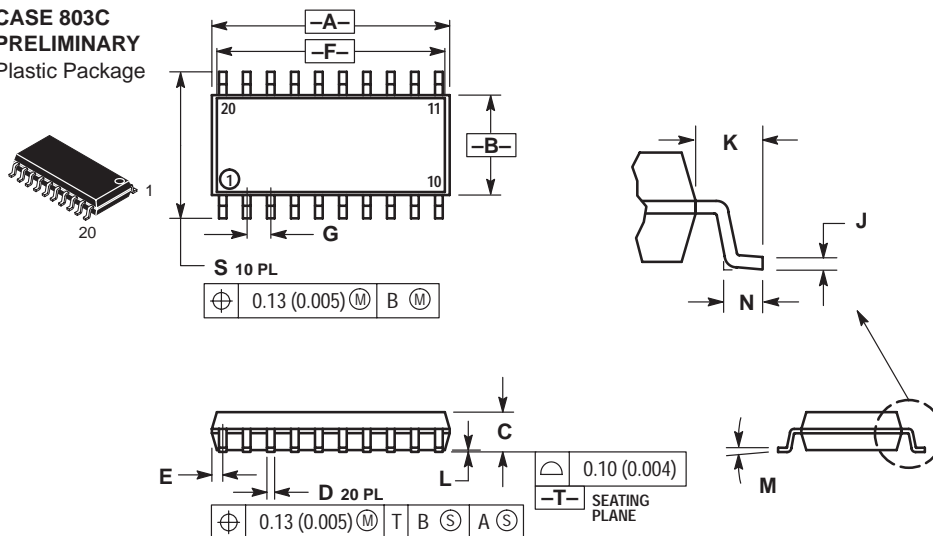

NOTES:

- DIMENSIONING AND TOLERANCING PER ANSI Y14.5M, 1982.
- CONTROLLING DIMENSION: MILLIMETER.
- DIMENSIONS A AND B DO NOT INCLUDE MOLD PROTRUSION.
- MAXIMUM MOLD PROTRUSION 0.15 (0.008) PER SIDE.
- DIMENSION D DOES NOT INCLUDE DAMBAR PROTRUSION. ALLOWABLE DAMBAR PROTRUSION SHALL BE 0.13 (0.006) TOTAL IN EXCESS OF THE D DIMENSION AT MAXIMUM MATERIAL CONDITION.

DIM	MILLIMETERS		INCHES	
	MIN	MAX	MIN	MAX
A	12.35	12.80	0.486	0.504
B	5.10	5.45	0.201	0.215
C	1.95	2.05	0.077	0.081
D	0.35	0.50	0.014	0.020
E	---	0.81	---	0.032
F	12.40*		0.488*	
G	1.15	1.39	0.045	0.055
H	0.59	0.81	0.023	0.032
J	0.18	0.27	0.007	0.011
K	1.10	1.50	0.043	0.059
L	0.05	0.20	0.001	0.008
M	0°	10°	0°	10°
N	0.50	0.85	0.020	0.033
S	7.40	8.20	0.291	0.323

*APPROXIMATE

TV SUFFIX
CASE 821C-04
 Plastic Package
 (15-Pin ZIP)
 ISSUE D

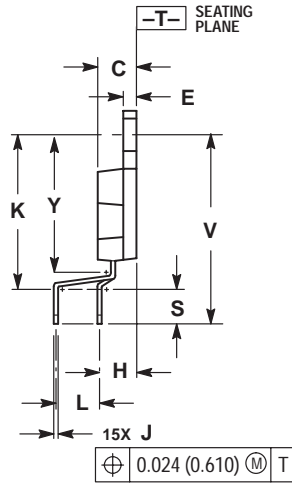
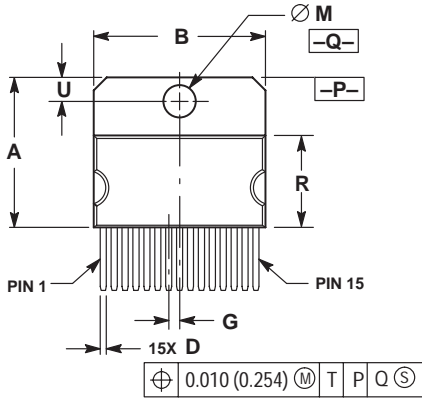
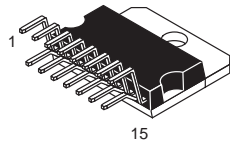

NOTES:

1. DIMENSIONING AND TOLERANCING PER ANSI Y14.5M, 1982.
2. CONTROLLING DIMENSION: INCH.
3. DIMENSION R DOES NOT INCLUDE MOLD FLASH OR PROTRUSIONS.
4. DIMENSION B DOES NOT INCLUDE MOLD FLASH OR PROTRUSIONS.
5. MOLD FLASH OR PROTRUSIONS SHALL NOT EXCEED 0.010 (0.250).
6. DIMENSION D DOES NOT INCLUDE DAMBAR PROTRUSION. ALLOWABLE PROTRUSION SHALL BE 0.003 (0.076) TOTAL IN EXCESS OF THE D DIMENSION, AT MAXIMUM MATERIAL CONDITION.

DIM	INCHES		MILLIMETERS	
	MIN	MAX	MIN	MAX
A	0.684	0.694	17.374	17.627
B	0.784	0.792	19.914	20.116
C	0.173	0.181	4.395	4.597
D	0.024	0.031	0.610	0.787
E	0.058	0.062	1.473	1.574
G	0.050 BSC		1.270 BSC	
H	0.169 BSC		4.293 BSC	
J	0.018	0.024	0.458	0.609
K	0.700	0.710	17.780	18.034
L	0.200 BSC		5.080 BSC	
M	0.148	0.151	3.760	3.835
R	0.416	0.426	10.567	10.820
S	0.157	0.167	3.988	4.242
U	0.105	0.115	2.667	2.921
V	0.868 REF		22.047 REF	
Y	0.625	0.639	15.875	16.231

T SUFFIX
CASE 821D-03
 Plastic Package
 ISSUE C

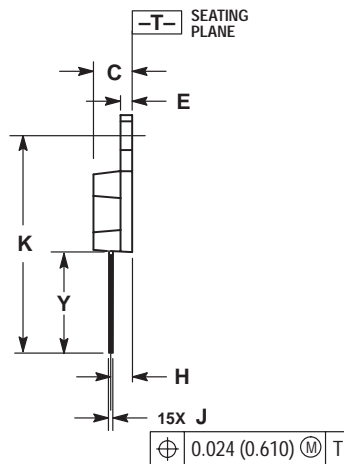
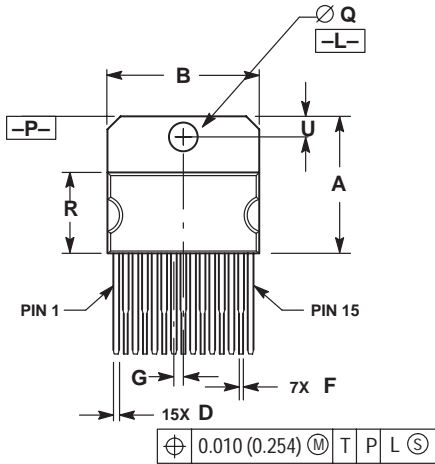
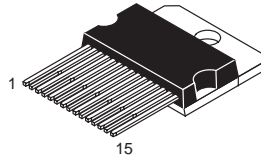

NOTES:

1. DIMENSIONING AND TOLERANCING PER ANSI Y14.5M, 1982.
2. CONTROLLING DIMENSION: INCH.
3. DIMENSION R DOES NOT INCLUDE MOLD FLASH OR PROTRUSIONS.
4. DIMENSION B DOES NOT INCLUDE MOLD FLASH OR PROTRUSIONS.
5. MOLD FLASH OR PROTRUSIONS SHALL NOT EXCEED 0.010 (0.250).
6. DELETED
7. DIMENSION D DOES NOT INCLUDE DAMBAR PROTRUSION. ALLOWABLE PROTRUSION SHALL BE 0.003 (0.076) TOTAL IN EXCESS OF THE D DIMENSION, AT MAXIMUM MATERIAL CONDITION.

DIM	INCHES		MILLIMETERS	
	MIN	MAX	MIN	MAX
A	0.681	0.694	17.298	17.627
B	0.784	0.792	19.914	20.116
C	0.173	0.181	4.395	4.597
D	0.024	0.031	0.610	0.787
E	0.058	0.062	1.473	1.574
F	0.016	0.023	0.407	0.584
G	0.050 BSC		1.270 BSC	
H	0.110 BSC		2.794 BSC	
J	0.018	0.024	0.458	0.609
K	1.078	1.086	27.382	27.584
Q	0.148	0.151	3.760	3.835
R	0.416	0.426	10.567	10.820
U	0.110 BSC		2.794 BSC	
Y	0.503 REF		12.776 REF	

FTB SUFFIX
CASE 824D-01
 Plastic Package
 (TQFP-44)
 ISSUE O

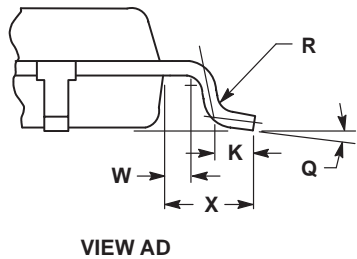
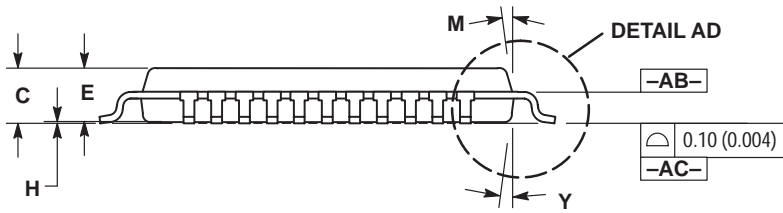
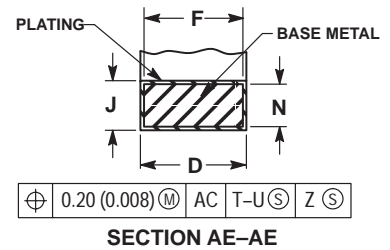
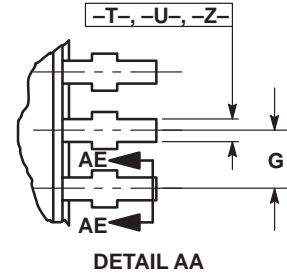
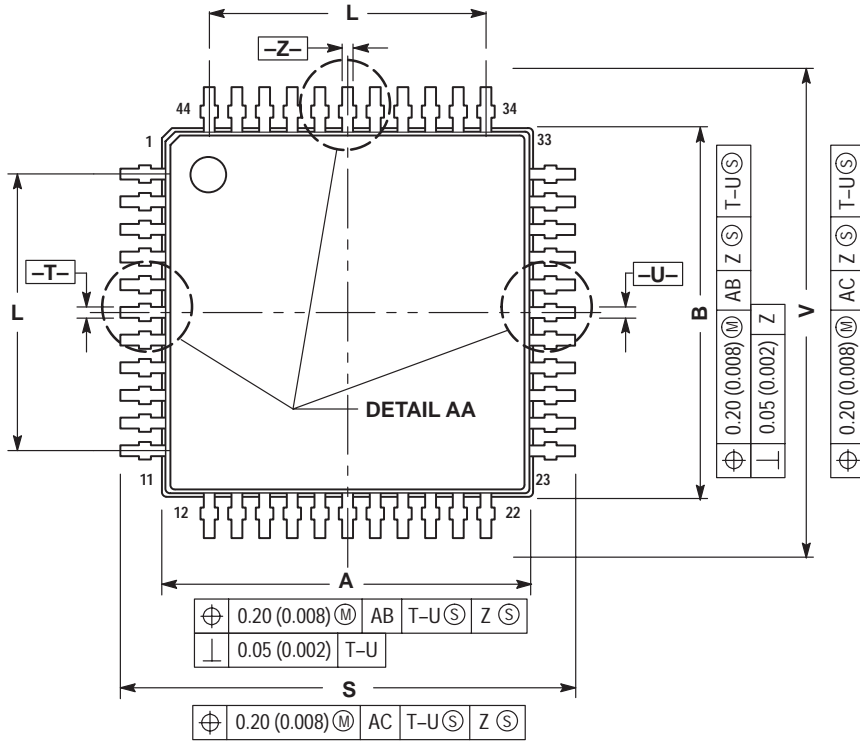
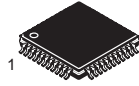

- NOTES:
1. DIMENSIONING AND TOLERANCING PER ANSI Y14.5M, 1982.
 2. CONTROLLING DIMENSION: MILLIMETER.
 3. DATUM PLANE -AB- IS LOCATED AT BOTTOM OF LEAD AND IS COINCIDENT WITH THE LEAD WHERE THE LEAD EXITS THE PLASTIC BODY AT THE BOTTOM OF THE PARTING LINE.
 4. DATUMS -T-, -U- AND -Z- TO BE DETERMINED AT DATUM PLANE -AB-.
 5. DIMENSIONS S AND V TO BE DETERMINED AT SEATING PLANE -AC-.
 6. DIMENSIONS A AND B DO NOT INCLUDE MOLD PROTRUSION. ALLOWABLE PROTRUSION IS 0.25 (0.010) PER SIDE. DIMENSIONS A AND B DO INCLUDE MOLD MISMATCH AND ARE DETERMINED AT DATUM PLANE -AB-.
 7. DIMENSION D DOES NOT INCLUDE DAMBAR PROTRUSION. DAMBAR PROTRUSION SHALL NOT CAUSE THE D DIMENSION TO EXCEED 0.530 (0.021).

DIM	MILLIMETERS		INCHES	
	MIN	MAX	MIN	MAX
A	9.950	10.050	0.392	0.396
B	9.950	10.050	0.392	0.396
C	1.400	1.600	0.055	0.063
D	0.300	0.450	0.012	0.018
E	1.350	1.450	0.053	0.057
F	0.300	0.400	0.012	0.016
G	0.800 BSC		0.031 BSC	
H	0.050	0.150	0.002	0.006
J	0.090	0.200	0.004	0.008
K	0.450	0.550	0.018	0.022
L	8.000 BSC		0.315 BSC	
M	12° REF		12° REF	
N	0.090	0.160	0.004	0.006
Q	1°	5°	1°	5°
R	0.100	0.200	0.004	0.008
S	11.900	12.100	0.469	0.476
V	11.900	12.100	0.469	0.476
W	0.200 REF		0.008 REF	
X	1.000 REF		0.039 REF	
Y	12° REF		12° REF	

FB SUFFIX
CASE 824E-02
 Plastic Package
 (QFP)
 ISSUE A

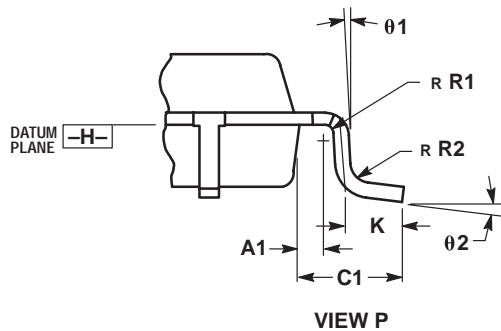
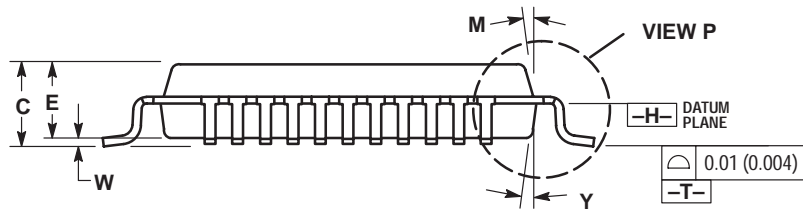
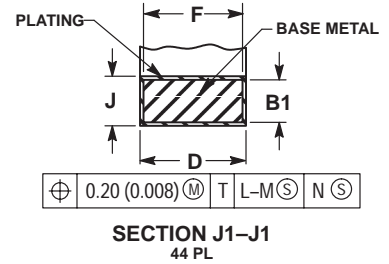
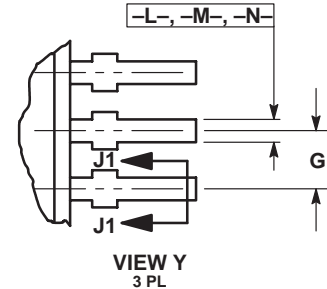
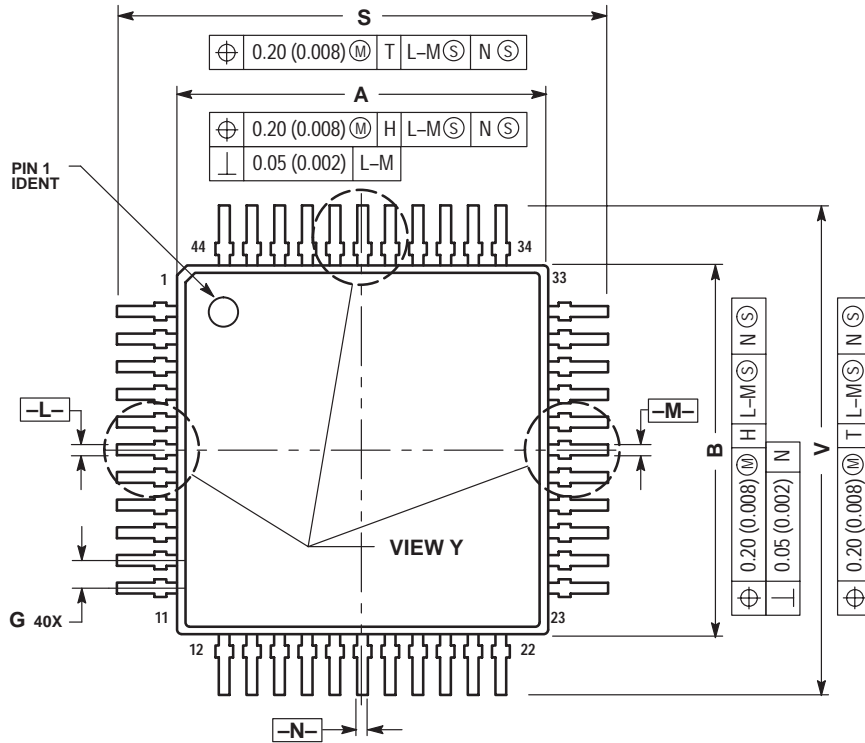
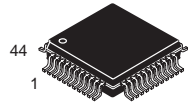

- NOTES:
1. DIMENSIONING AND TOLERANCING PER ANSI Y14.5M, 1982.
 2. CONTROLLING DIMENSION: MILLIMETER.
 3. DATUM PLANE -H- IS LOCATED AT BOTTOM OF LEAD AND IS COINCIDENT WITH THE LEAD WHERE THE LEAD EXITS THE PLASTIC BODY AT THE BOTTOM OF THE PARTING LINE.
 4. DATUMS -L-, -M- AND -N- TO BE DETERMINED AT DATUM PLANE -H-.
 5. DIMENSIONS S AND V TO BE DETERMINED AT SEATING PLANE -T-.
 6. DIMENSIONS A AND B DO NOT INCLUDE MOLD PROTRUSION. ALLOWABLE PROTRUSION IS 0.25 (0.010) PER SIDE. DIMENSIONS A AND B DO INCLUDE MOLD MISMATCH AND ARE DETERMINED AT DATUM PLANE -H-.
 7. DIMENSION D DOES NOT INCLUDE DAMBAR PROTRUSION. DAMBAR PROTRUSION SHALL NOT CAUSE THE D DIMENSION TO EXCEED 0.530 (0.021).

DIM	MILLIMETERS		INCHES	
	MIN	MAX	MIN	MAX
A	9.90	10.10	0.390	0.398
B	9.90	10.10	0.390	0.398
C	2.00	2.21	0.079	0.087
D	0.30	0.45	0.0118	0.0177
E	2.00	2.10	0.079	0.083
F	0.30	0.40	0.012	0.016
G	0.80 BSC		0.031 BSC	
J	0.13	0.23	0.005	0.009
K	0.65	0.95	0.026	0.037
M	5° 10°		5° 10°	
S	12.95	13.45	0.510	0.530
V	12.95	13.45	0.510	0.530
W	0.000	0.210	0.000	0.008
Y	5° 10°		5° 10°	
A1	0.450 REF		0.018 REF	
B1	0.130	0.170	0.005	0.007
C1	1.600 REF		0.063 REF	
R1	0.130	0.300	0.005	0.012
R2	0.130	0.300	0.005	0.012
theta 1	5° 10°		5° 10°	
theta 2	0° 7°		0° 7°	

FB SUFFIX
CASE 840F-01
 Plastic Package
 ISSUE O

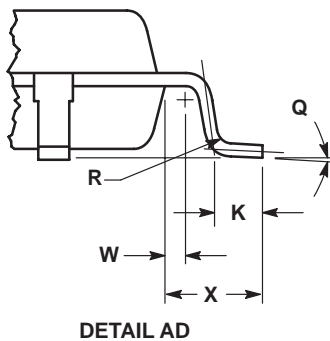
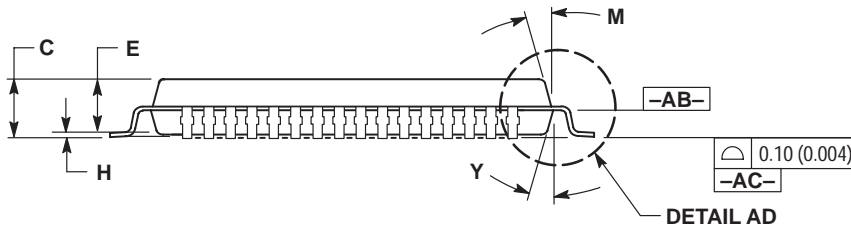
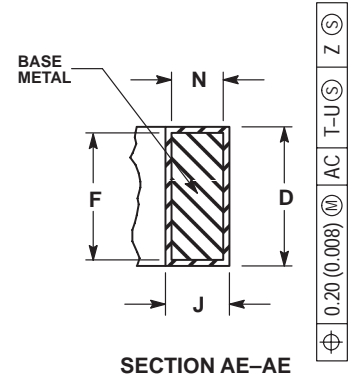
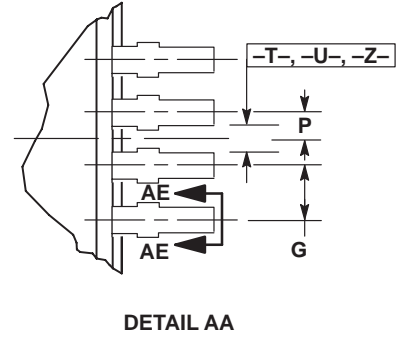
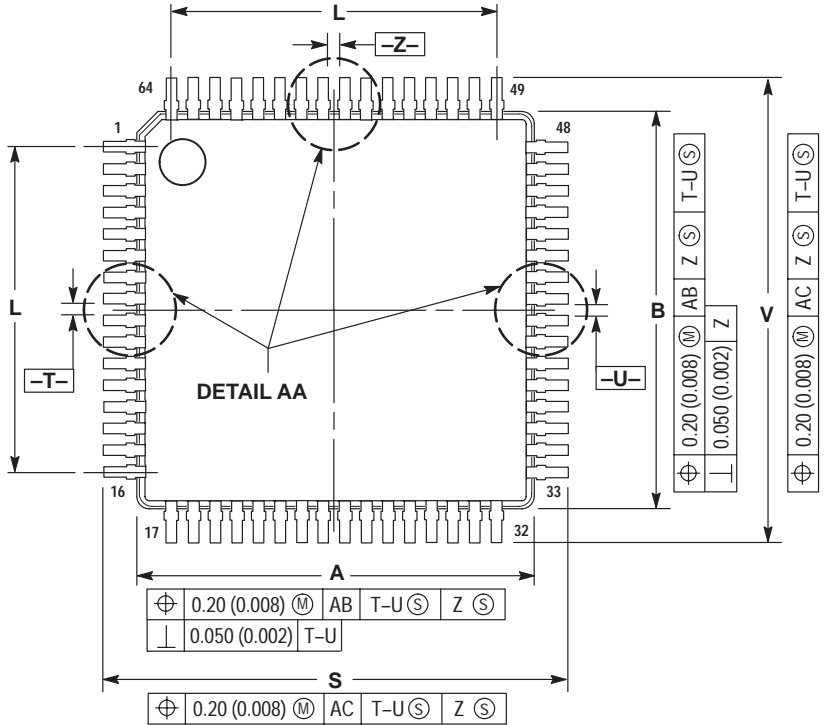
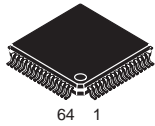

- NOTES:
1. DIMENSIONING AND TOLERANCING PER ANSI Y14.5M, 1982.
 2. CONTROLLING DIMENSION: MILLIMETER.
 3. DATUM PLANE -AB- IS LOCATED AT BOTTOM OF LEAD AND IS COINCIDENT WITH THE LEAD WHERE THE LEAD EXITS THE PLASTIC BODY AT THE BOTTOM OF THE PARTING LINE.
 4. DATUMS -T-, -U- AND -Z- TO BE DETERMINED AT DATUM PLANE -AC-.
 5. DIMENSIONS S AND V TO BE DETERMINED AT SEATING PLANE -AC-.
 6. DIMENSIONS A AND B DO NOT INCLUDE MOLD PROTRUSION. ALLOWABLE PROTRUSION IS 0.25 (0.010) PER SIDE. DIMENSIONS A AND B DO INCLUDE MOLD MISMATCH AND ARE DETERMINED AT DATUM PLANE -AB-.
 7. DIMENSION D DOES NOT INCLUDE DAMBAR PROTRUSION. DAMBAR PROTRUSION SHALL NOT CAUSE THE D DIMENSION TO EXCEED 0.350 (0.014).

DIM	MILLIMETERS		INCHES	
	MIN	MAX	MIN	MAX
A	9.950	10.050	0.392	0.396
B	9.950	10.050	0.392	0.396
C	1.400	1.600	0.055	0.063
D	0.170	0.270	0.007	0.011
E	1.350	1.450	0.053	0.057
F	0.170	0.230	0.007	0.009
G	0.500 BSC		0.020 BSC	
H	0.050	0.150	0.002	0.006
J	0.090	0.200	0.004	0.008
K	0.450	0.550	0.018	0.022
L	7.500 BSC		0.295 BSC	
M	12° REF		12° REF	
N	0.090	0.160	0.004	0.006
P	0.250 BSC		0.010 BSC	
Q	1°	5°	1°	5°
R	0.100	0.200	0.004	0.008
S	11.900	12.100	0.469	0.476
V	11.900	12.100	0.469	0.476
W	0.200 REF		0.008 REF	
X	1.000 REF		0.039 REF	
Y	12° REF		12° REF	

DM SUFFIX
CASE 846A-02
 Plastic Package
 (Micro-8)
 ISSUE C

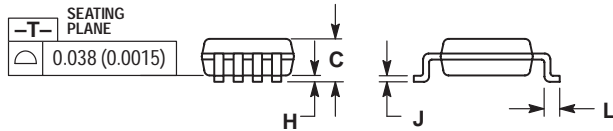
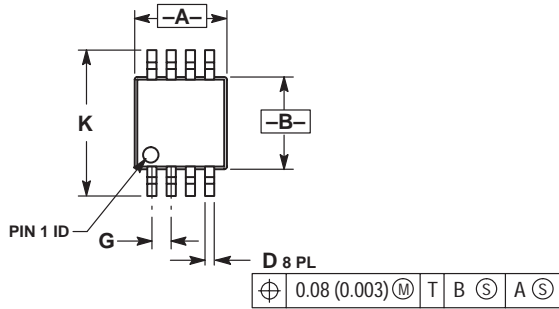

NOTES:

1. DIMENSIONING AND TOLERANCING PER ANSI Y14.5M, 1982.
2. CONTROLLING DIMENSION: MILLIMETER.
3. DIMENSION A DOES NOT INCLUDE MOLD FLASH, PROTRUSIONS OR GATE BURRS. MOLD FLASH, PROTRUSIONS OR GATE BURRS SHALL NOT EXCEED 0.15 (0.006) PER SIDE.
4. DIMENSION B DOES NOT INCLUDE INTERLEAD FLASH OR PROTRUSION. INTERLEAD FLASH OR PROTRUSION SHALL NOT EXCEED 0.25 (0.010) PER SIDE.

DIM	MILLIMETERS		INCHES	
	MIN	MAX	MIN	MAX
A	2.90	3.10	0.114	0.122
B	2.90	3.10	0.114	0.122
C	---	1.10	---	0.043
D	0.25	0.40	0.010	0.016
G	0.65 BSC		0.026 BSC	
H	0.05	0.15	0.002	0.006
J	0.13	0.23	0.005	0.009
K	4.75	5.05	0.187	0.199
L	0.40	0.70	0.016	0.028

FB SUFFIX
CASE 848B-04
 Plastic Package
 (TQFP-52)
 ISSUE C

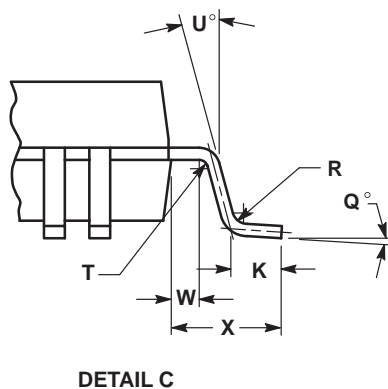
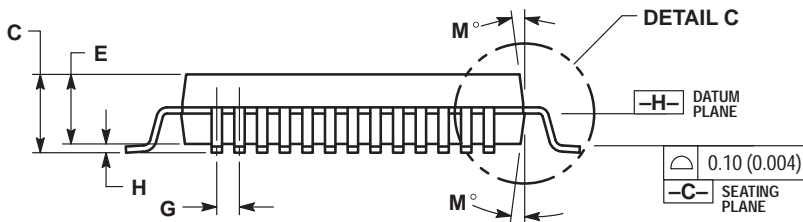
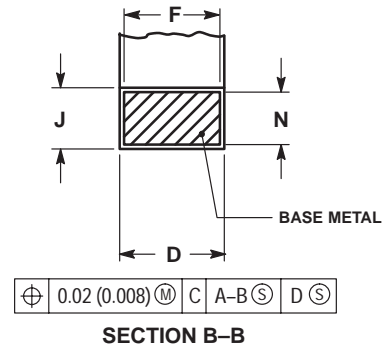
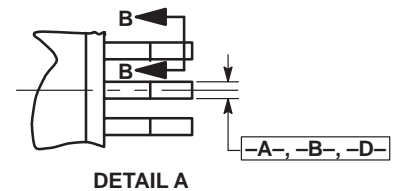
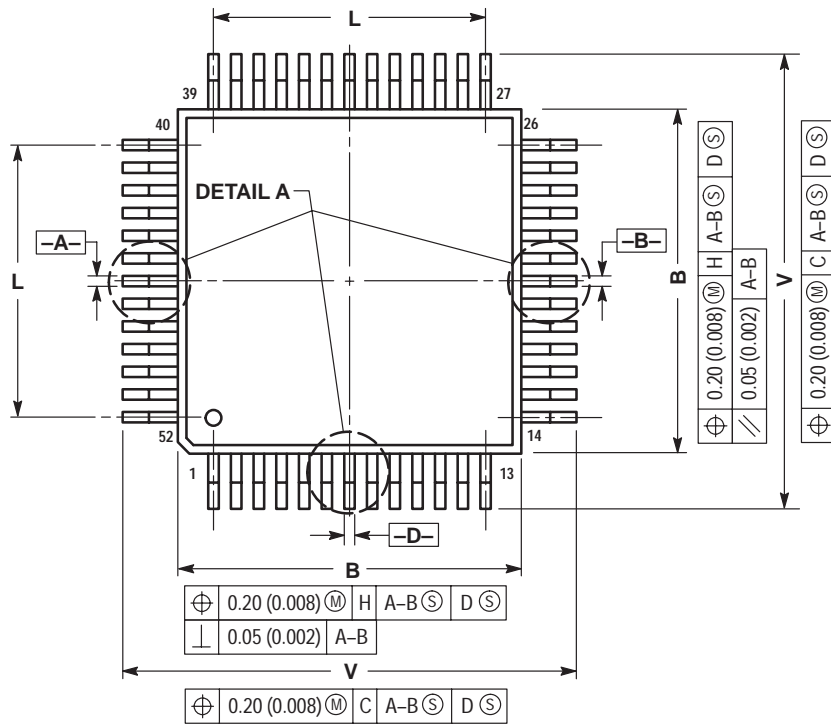
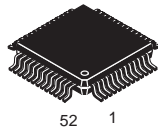

- NOTES:
- DIMENSIONING AND TOLERANCING PER ANSI Y14.5M, 1982.
 - CONTROLLING DIMENSION: MILLIMETER.
 - DATUM PLANE -H- IS LOCATED AT BOTTOM OF LEAD AND IS COINCIDENT WITH THE LEAD WHERE THE LEAD EXITS THE PLASTIC BODY AT THE BOTTOM OF THE PARTING LINE.
 - DATUMS -A-, -B- AND -D- TO BE DETERMINED AT DATUM PLANE -H-.
 - DIMENSIONS S AND V TO BE DETERMINED AT SEATING PLANE -C-.
 - DIMENSIONS A AND B DO NOT INCLUDE MOLD PROTRUSION. ALLOWABLE PROTRUSION IS 0.25 (0.010) PER SIDE. DIMENSIONS A AND B DO INCLUDE MOLD MISMATCH AND ARE DETERMINED AT DATUM PLANE -H-.
 - DIMENSION D DOES NOT INCLUDE DAMBAR PROTRUSION. ALLOWABLE DAMBAR PROTRUSION SHALL BE 0.08 (0.003) TOTAL IN EXCESS OF THE D DIMENSION AT MAXIMUM MATERIAL CONDITION. DAMBAR CANNOT BE LOCATED ON THE LOWER RADIUS OR THE FOOT.

DIM	MILLIMETERS		INCHES	
	MIN	MAX	MIN	MAX
A	9.90	10.10	0.390	0.398
B	9.90	10.10	0.390	0.398
C	2.10	2.45	0.083	0.096
D	0.22	0.38	0.009	0.015
E	2.00	2.10	0.079	0.083
F	0.22	0.33	0.009	0.013
G	0.65 BSC		0.026 BSC	
H	---	0.25	---	0.010
J	0.13	0.23	0.005	0.009
K	0.65	0.95	0.026	0.037
L	7.80 REF		0.307 REF	
M	5°	10°	5°	10°
N	0.13	0.17	0.005	0.007
Q	0°	7°	0°	7°
R	0.13	0.30	0.005	0.012
S	12.95	13.45	0.510	0.530
T	0.13	---	0.005	---
U	0°	---	0°	---
V	12.95	13.45	0.510	0.530
W	0.35	0.45	0.014	0.018
X	1.6 REF		0.063 REF	

FB SUFFIX
CASE 848D-03
 Plastic Package
 ISSUE C

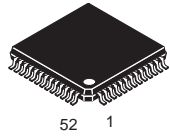

52 1

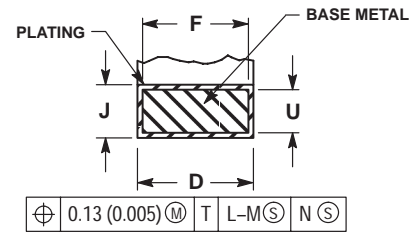
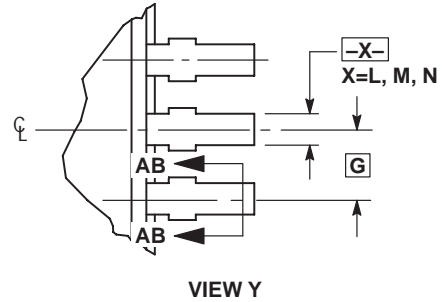
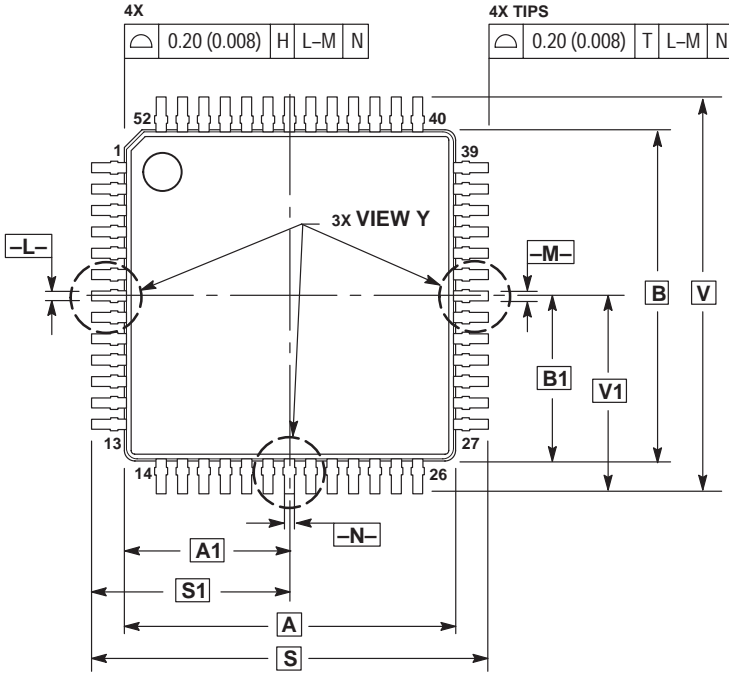

SECTION AB-AB
 ROTATED 90° CLOCKWISE

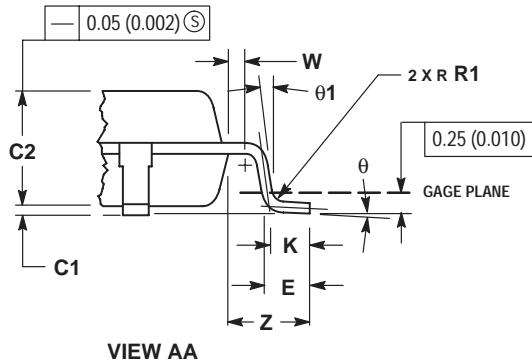
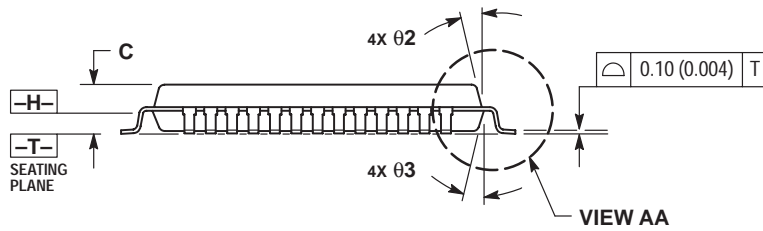

- NOTES:**
1. DIMENSIONING AND TOLERANCING PER ANSI Y14.5M, 1982.
 2. CONTROLLING DIMENSION: MILLIMETER.
 3. DATUM PLANE -H- IS LOCATED AT BOTTOM OF LEAD AND IS COINCIDENT WITH THE LEAD WHERE THE LEAD EXITS THE PLASTIC BODY AT THE BOTTOM OF THE PARTING LINE.
 4. DATUMS -L-, -M- AND -N- TO BE DETERMINED AT DATUM PLANE -H-.
 5. DIMENSIONS S AND V TO BE DETERMINED AT SEATING PLANE -T-.
 6. DIMENSIONS A AND B DO NOT INCLUDE MOLD PROTRUSION. ALLOWABLE PROTRUSION IS 0.25 (0.010) PER SIDE. DIMENSIONS A AND B DO NOT INCLUDE MOLD MISMATCH AND ARE DETERMINED AT DATUM PLANE -H-.
 7. DIMENSION D DOES NOT INCLUDE DAMBAR PROTRUSION. DAMBAR PROTRUSION SHALL NOT CAUSE THE LEAD WIDTH TO EXCEED 0.46 (0.018). MINIMUM SPACE BETWEEN PROTRUSION AND ADJACENT LEAD OR PROTRUSION 0.07 (0.003).

DIM	MILLIMETERS		INCHES	
	MIN	MAX	MIN	MAX
A	10.00 BSC	0.394 BSC		
A1	5.00 BSC	0.197 BSC		
B	10.00 BSC	0.394 BSC		
B1	5.00 BSC	0.197 BSC		
C	---	1.70	---	0.067
C1	0.05	0.20	0.002	0.008
C2	1.30	1.50	0.051	0.059
D	0.20	0.40	0.008	0.016
E	0.45	0.75	0.018	0.030
F	0.22	0.35	0.009	0.014
G	0.65 BSC	0.026 BSC		
J	0.07	0.20	0.003	0.008
K	0.50 REF	0.020 REF		
R1	0.08	0.20	0.003	0.008
S	12.00 BSC	0.472 BSC		
S1	6.00 BSC	0.236 BSC		
U	0.09	0.16	0.004	0.006
V	12.00 BSC	0.472 BSC		
V1	6.00 BSC	0.236 BSC		
W	0.20 REF	0.008 REF		
Z	1.00 REF	0.039 REF		
theta	0°	7°	0°	7°
theta 1	0°	---	0°	---
theta 2	12° REF	12° REF		
theta 3	5°	13°	5°	13°

B SUFFIX
CASE 858-01
 Plastic Package
 ISSUE O

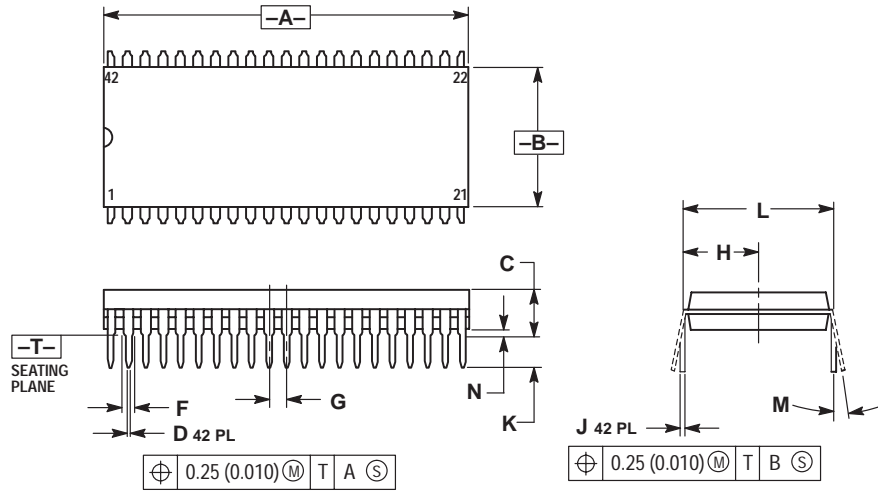
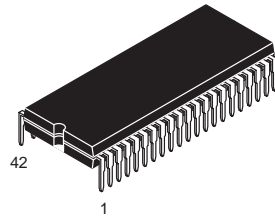

- NOTES:
1. DIMENSIONING AND TOLERANCING PER ANSI Y14.5M, 1982.
 2. CONTROLLING DIMENSION: INCH.
 3. DIMENSION L TO CENTER OF LEAD WHEN FORMED PARALLEL.
 4. DIMENSIONS A AND B DO NOT INCLUDE MOLD FLASH. MAXIMUM MOLD FLASH 0.25 (0.010).

DIM	INCHES		MILLIMETERS	
	MIN	MAX	MIN	MAX
A	1.435	1.465	36.45	37.21
B	0.540	0.560	13.72	14.22
C	0.155	0.200	3.94	5.08
D	0.014	0.022	0.36	0.56
F	0.032	0.046	0.81	1.17
G	0.070 BSC		1.778 BSC	
H	0.300 BSC		7.62 BSC	
J	0.008	0.015	0.20	0.38
K	0.115	0.135	2.92	3.43
L	0.600 BSC		15.24 BSC	
M	0°	15°	0°	15°
N	0.020	0.040	0.51	1.02

B SUFFIX
CASE 859-01
 Plastic Package (SDIP)
 ISSUE O

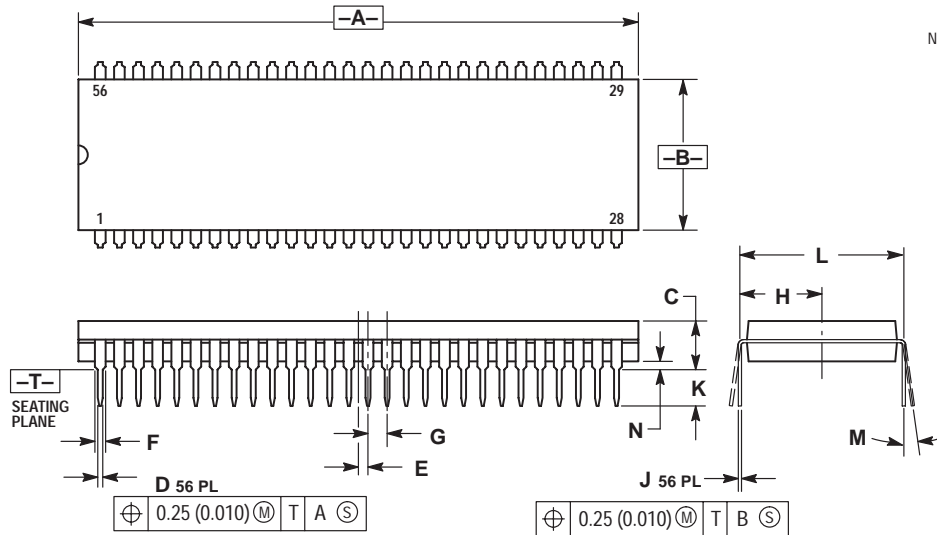
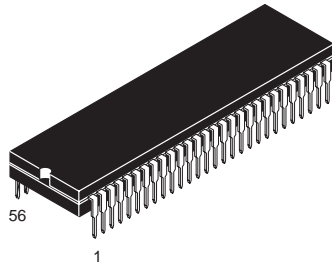

- NOTES:
1. DIMENSIONING AND TOLERANCING PER ANSI Y14.5M, 1982.
 2. CONTROLLING DIMENSION: INCH.
 3. DIMENSION L TO CENTER OF LEAD WHEN FORMED PARALLEL.
 4. DIMENSIONS A AND B DO NOT INCLUDE MOLD FLASH. MAXIMUM MOLD FLASH 0.25 (0.010)

DIM	INCHES		MILLIMETERS	
	MIN	MAX	MIN	MAX
A	2.035	2.065	51.69	52.45
B	0.540	0.560	13.72	14.22
C	0.155	0.200	3.94	5.08
D	0.014	0.022	0.36	0.56
E	0.035 BSC		0.89 BSC	
F	0.032	0.046	0.81	1.17
G	0.070 BSC		1.778 BSC	
H	0.300 BSC		7.62 BSC	
J	0.008	0.015	0.20	0.38
K	0.115	0.135	2.92	3.43
L	0.600 BSC		15.24 BSC	
M	0°	15°	0°	15°
N	0.020	0.040	0.51	1.02

FB, FTB SUFFIX
CASE 873-01
 Plastic Package
 (TQFP-32)
 ISSUE A

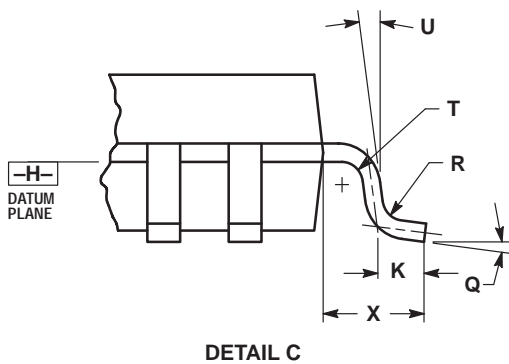
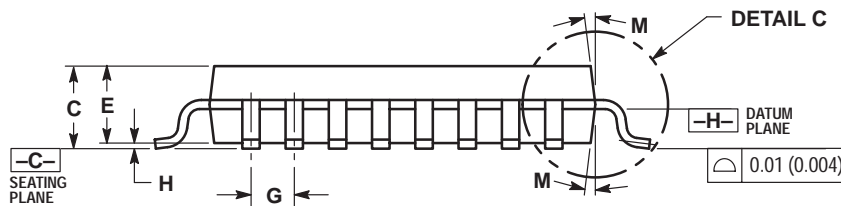
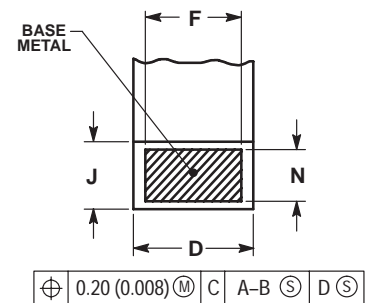
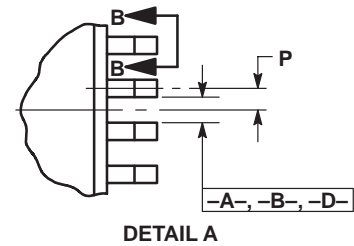
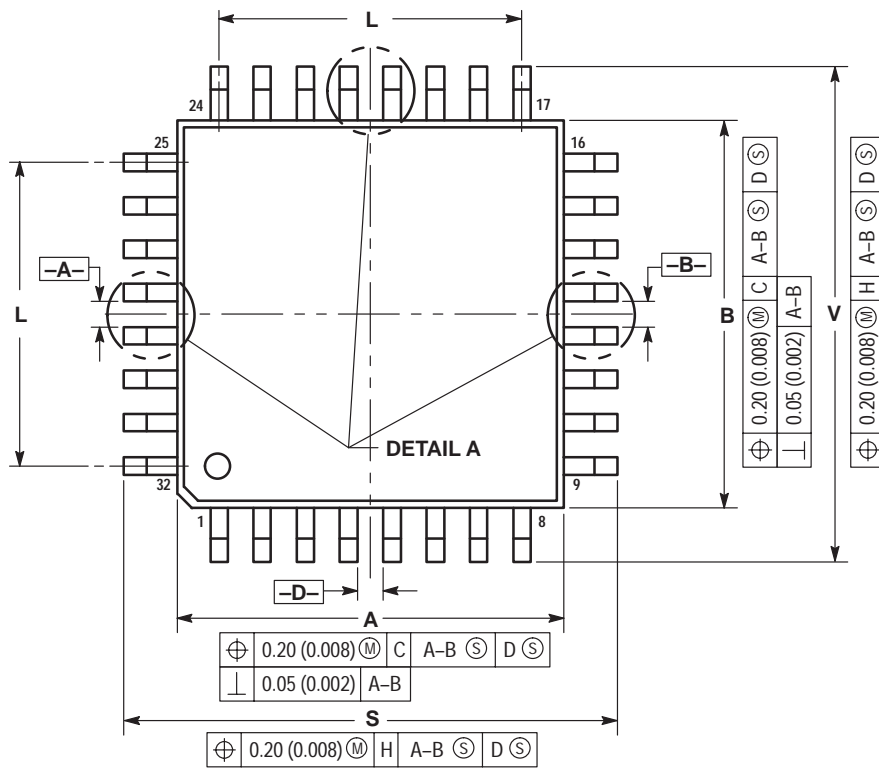
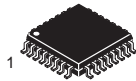

NOTES:

- DIMENSION AND TOLERANCING PER ANSI Y14.5M, 1982.
- CONTROLLING DIMENSION: MILLIMETER.
- DATUM PLANE -H- IS LOCATED AT BOTTOM OF LEAD AND IS COINCIDENT WITH THE LEAD WHERE THE LEAD EXITS THE PLASTIC BODY AT THE BOTTOM OF THE PARTING LINE.
- DATUMS -A-, -B- AND -D- TO BE DETERMINED AT DATUM PLANE -H-.
- DIMENSIONS S AND V TO BE DETERMINED AT SEATING PLANE -C-.
- DIMENSIONS A AND B DO NOT INCLUDE MOLD PROTRUSION. ALLOWABLE PROTRUSION IS 0.25 (0.010) PER SIDE. DIMENSIONS A AND B DO INCLUDE MOLD MISMATCH AND ARE DETERMINED AT DATUM PLANE -H-.
- DIMENSION D DOES NOT INCLUDE DAMBAR PROTRUSION. ALLOWABLE DAMBAR PROTRUSION SHALL BE 0.08 (0.003) TOTAL IN EXCESS OF THE D DIMENSION AT MAXIMUM MATERIAL CONDITION. DAMBAR CANNOT BE LOCATED ON THE LOWER RADIUS OR THE FOOT.

DIM	MILLIMETERS		INCHES	
	MIN	MAX	MIN	MAX
A	6.95	7.10	0.274	0.280
B	6.95	7.10	0.274	0.280
C	1.40	1.60	0.055	0.063
D	0.273	0.373	0.010	0.015
E	1.30	1.50	0.051	0.059
F	0.273	---	0.010	---
G	0.80	BSC	0.031	BSC
H	---	0.20	---	0.008
J	0.119	0.197	0.005	0.008
K	0.33	0.57	0.013	0.022
L	5.6	REF	0.220	REF
M	6°	8°	6°	8°
N	0.119	0.135	0.005	0.005
P	0.40	BSC	0.016	BSC
Q	5°	10°	5°	10°
R	0.15	0.25	0.006	0.010
S	8.85	9.15	0.348	0.360
T	0.15	0.25	0.006	0.010
U	5°	11°	5°	11°
V	8.85	9.15	0.348	0.360
X	1.00	REF	0.039	REF

T SUFFIX
CASE 894-03
 Plastic Package
 (23-Pin SZIP)
 ISSUE B

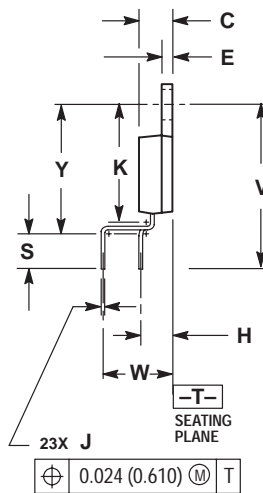
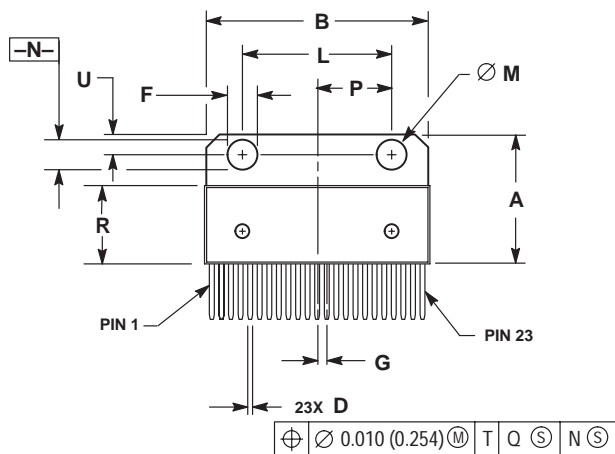
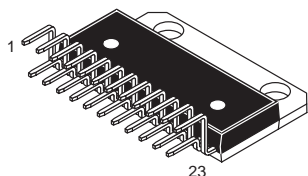

NOTES:

1. DIMENSIONING AND TOLERANCING PER ANSI Y14.5M, 1982.
2. CONTROLLING DIMENSION: INCH.
3. DIMENSION R DOES NOT INCLUDE MOLD FLASH OR PROTRUSIONS.
4. DIMENSION B DOES NOT INCLUDE MOLD FLASH OR PROTRUSIONS.
5. MOLD FLASH OR PROTRUSIONS SHALL NOT EXCEED 0.010 (0.250).
6. DIMENSION D DOES NOT INCLUDE DAMBAR PROTRUSION. ALLOWABLE PROTRUSION SHALL BE 0.003 (0.076) TOTAL IN EXCESS OF THE D DIMENSION AT MAXIMUM MATERIAL CONDITION.

DIM	INCHES		MILLIMETERS	
	MIN	MAX	MIN	MAX
A	0.684	0.694	17.374	17.627
B	1.183	1.193	30.048	30.302
C	0.175	0.179	4.445	4.547
D	0.026	0.031	0.660	0.787
E	0.058	0.062	1.473	1.574
F	0.165	0.175	4.191	4.445
G	0.050 BSC		1.270 BSC	
H	0.169 BSC		4.293 BSC	
J	0.014	0.020	0.356	0.508
K	0.625	0.639	15.875	16.231
L	0.770	0.790	19.558	20.066
M	0.148	0.152	3.760	3.861
N	0.148	0.152	3.760	3.861
P	0.390 BSC		9.906 BSC	
R	0.416	0.424	10.566	10.770
S	0.157	0.167	3.988	4.242
U	0.105	0.115	2.667	2.921
V	0.868 REF		22.047 REF	
W	0.200 BSC		5.080 BSC	
Y	0.700	0.710	17.780	18.034

FTA SUFFIX
CASE 932-02
 Plastic Package
 (TQFP-48)
 ISSUE D

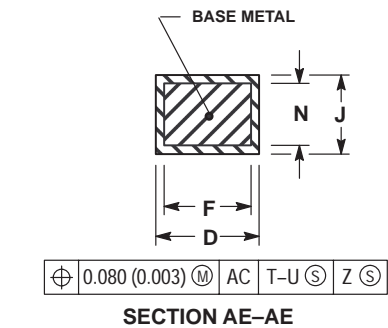
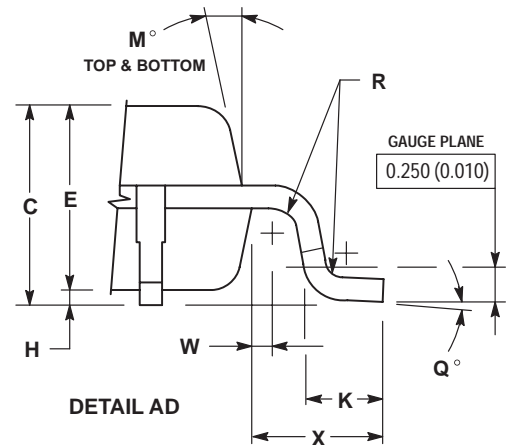
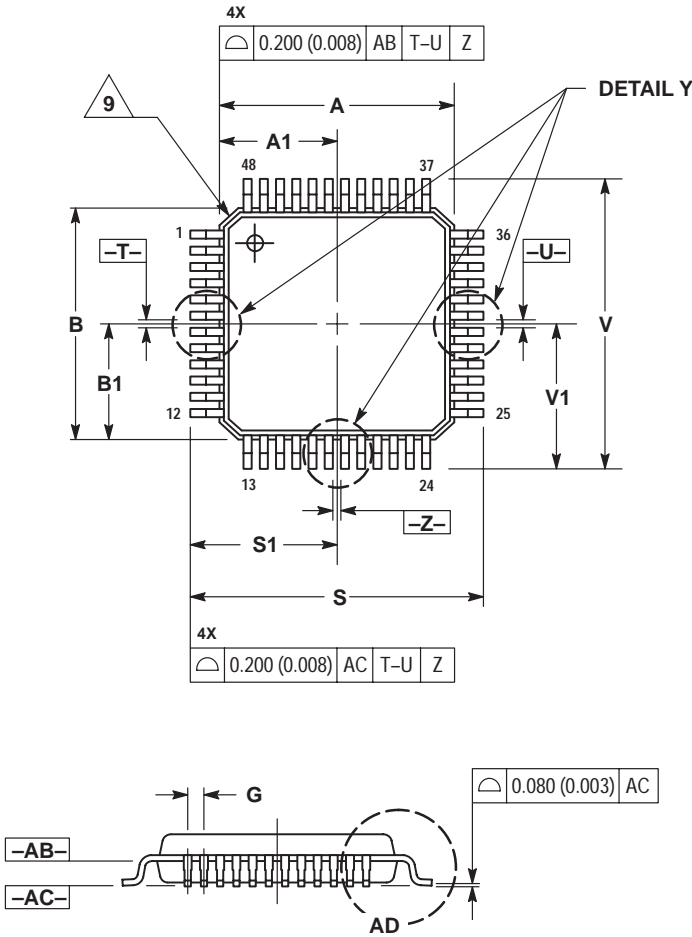
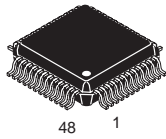

- NOTES:
1. DIMENSIONING AND TOLERANCING PER ANSI Y14.5M, 1982.
 2. CONTROLLING DIMENSION: MILLIMETER.
 3. DATUM PLANE -AB- IS LOCATED AT BOTTOM OF LEAD AND IS COINCIDENT WITH THE LEAD WHERE THE LEAD EXITS THE PLASTIC BODY AT THE BOTTOM OF THE PARTING LINE.
 4. DATUMS -T-, -U-, AND -Z- TO BE DETERMINED AT DATUM PLANE -AB-.
 5. DIMENSIONS S AND V TO BE DETERMINED AT SEATING PLANE -AC-.
 6. DIMENSIONS A AND B DO NOT INCLUDE MOLD PROTRUSION. ALLOWABLE PROTRUSION IS 0.250 (0.010) PER SIDE. DIMENSIONS A AND B DO NOT INCLUDE MOLD MISMATCH AND ARE DETERMINED AT DATUM PLANE -AB-.
 7. DIMENSION D DOES NOT INCLUDE DAMBAR PROTRUSION. DAMBAR PROTRUSION SHALL NOT CAUSE THE D DIMENSION TO EXCEED 0.350 (0.014).
 8. MINIMUM SOLDER PLATE THICKNESS SHALL BE 0.0076 (0.0003).
 9. EXACT SHAPE OF EACH CORNER IS OPTIONAL.

DIM	MILLIMETERS		INCHES	
	MIN	MAX	MIN	MAX
A	7.000 BSC		0.276 BSC	
A1	3.500 BSC		0.138 BSC	
B	7.000 BSC		0.276 BSC	
B1	3.500 BSC		0.138 BSC	
C	1.400	1.600	0.055	0.063
D	0.170	0.270	0.007	0.011
E	1.350	1.450	0.053	0.057
F	0.170	0.230	0.007	0.009
G	0.500 BASIC		0.020 BASIC	
H	0.050	0.150	0.002	0.006
J	0.090	0.200	0.004	0.008
K	0.500	0.700	0.020	0.028
M	12° REF		12° REF	
N	0.090	0.160	0.004	0.006
P	0.250 BASIC		0.010 BASIC	
Q	1°	5°	1°	5°
R	0.150	0.250	0.006	0.010
S	9.000 BSC		0.354 BSC	
S1	4.500 BSC		0.177 BSC	
V	9.000 BSC		0.354 BSC	
V1	4.500 BSC		0.177 BSC	
W	0.200 REF		0.008 REF	
X	1.000 REF		0.039 REF	

D2T SUFFIX
CASE 936-03
 Plastic Package
 ISSUE B

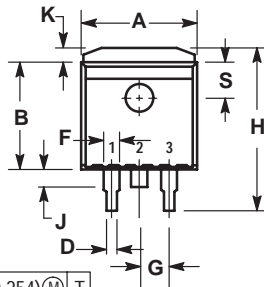
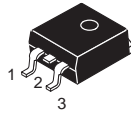

\oplus 0.010 (0.254) $\text{\textcircled{M}}$ T

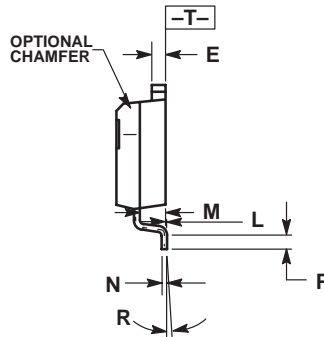
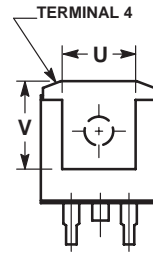
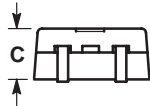

- NOTES:
1. DIMENSIONING AND TOLERANCING PER ANSI Y14.5M, 1982.
 2. CONTROLLING DIMENSION: INCH.
 3. TAB CONTOUR OPTIONAL WITHIN DIMENSIONS A AND K.
 4. DIMENSIONS U AND V ESTABLISH A MINIMUM MOUNTING SURFACE FOR TERMINAL 4.
 5. DIMENSIONS A AND B DO NOT INCLUDE MOLD FLASH OR GATE PROTRUSIONS. MOLD FLASH AND GATE PROTRUSIONS NOT TO EXCEED 0.025 (0.635) MAXIMUM.

DIM	INCHES		MILLIMETERS	
	MIN	MAX	MIN	MAX
A	0.386	0.403	9.804	10.236
B	0.356	0.368	9.042	9.347
C	0.170	0.180	4.318	4.572
D	0.026	0.036	0.660	0.914
E	0.045	0.055	1.143	1.397
F	0.051 REF		1.295 REF	
G	0.100 BSC		2.540 BSC	
H	0.539	0.579	13.691	14.707
J	0.125 MAX		3.175 MAX	
K	0.050 REF		1.270 REF	
L	0.000	0.010	0.000	0.254
M	0.088	0.102	2.235	2.591
N	0.018	0.026	0.457	0.660
P	0.058	0.078	1.473	1.981
R	5° REF		5° REF	
S	0.116 REF		2.946 REF	
U	0.200 MIN		5.080 MIN	
V	0.250 MIN		6.350 MIN	

D2T SUFFIX
CASE 936A-02
 Plastic Package
 (D²PAK)
 ISSUE A

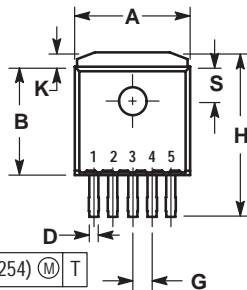
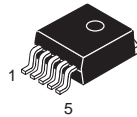

\oplus 0.010 (0.254) $\text{\textcircled{M}}$ T

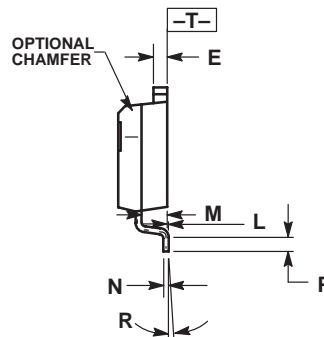
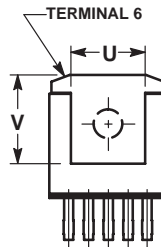
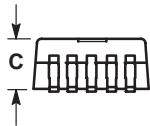

- NOTES:
1. DIMENSIONING AND TOLERANCING PER ANSI Y14.5M, 1982.
 2. CONTROLLING DIMENSION: INCH.
 3. TAB CONTOUR OPTIONAL WITHIN DIMENSIONS A AND K.
 4. DIMENSIONS U AND V ESTABLISH A MINIMUM MOUNTING SURFACE FOR TERMINAL 6.
 5. DIMENSIONS A AND B DO NOT INCLUDE MOLD FLASH OR GATE PROTRUSIONS. MOLD FLASH AND GATE PROTRUSIONS NOT TO EXCEED 0.025 (0.635) MAXIMUM.

DIM	INCHES		MILLIMETERS	
	MIN	MAX	MIN	MAX
A	0.386	0.403	9.804	10.236
B	0.356	0.368	9.042	9.347
C	0.170	0.180	4.318	4.572
D	0.026	0.036	0.660	0.914
E	0.045	0.055	1.143	1.397
G	0.067 BSC		1.702 BSC	
H	0.539	0.579	13.691	14.707
K	0.050 REF		1.270 REF	
L	0.000	0.010	0.000	0.254
M	0.088	0.102	2.235	2.591
N	0.018	0.026	0.457	0.660
P	0.058	0.078	1.473	1.981
R	5° REF		5° REF	
S	0.116 REF		2.946 REF	
U	0.200 MIN		5.080 MIN	
V	0.250 MIN		6.350 MIN	

DT, DTB SUFFIX
CASE 948E-02
 Plastic Package
 (TSSOP-20)
 ISSUE A

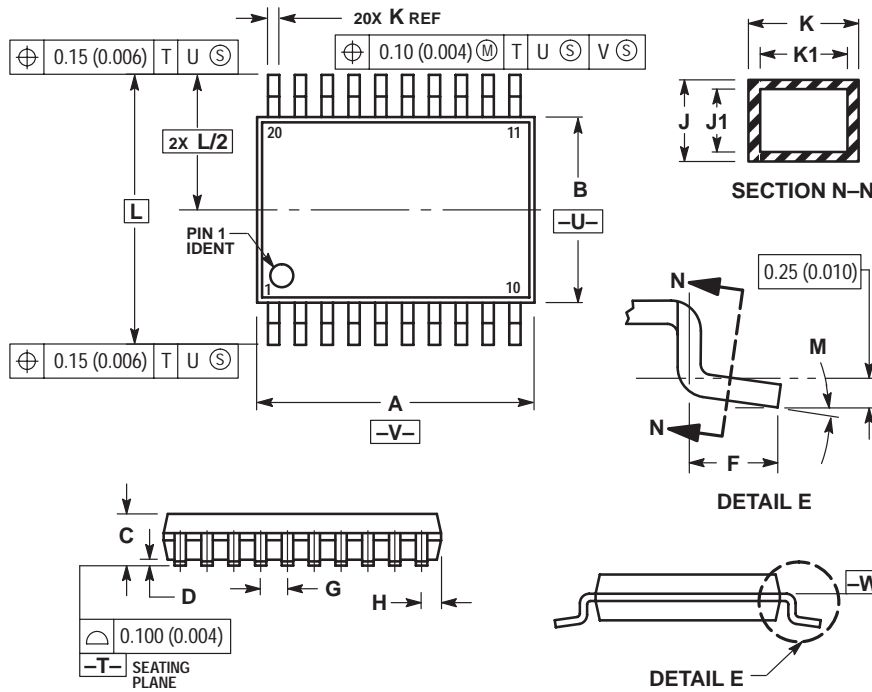
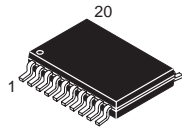

- NOTES:
1. DIMENSIONING AND TOLERANCING PER ANSI Y14.5M, 1982.
 2. CONTROLLING DIMENSION: MILLIMETER.
 3. DIMENSION A DOES NOT INCLUDE MOLD FLASH, PROTRUSIONS OR GATE BURRS. MOLD FLASH OR GATE BURRS SHALL NOT EXCEED 0.15 (0.006) PER SIDE.
 4. DIMENSION B DOES NOT INCLUDE INTERLEAD FLASH OR PROTRUSION. INTERLEAD FLASH OR PROTRUSION SHALL NOT EXCEED 0.25 (0.010) PER SIDE.
 5. DIMENSION K DOES NOT INCLUDE DAMBAR PROTRUSION. ALLOWABLE DAMBAR PROTRUSION SHALL BE 0.08 (0.003) TOTAL IN EXCESS OF THE K DIMENSION AT MAXIMUM MATERIAL CONDITION.
 6. TERMINAL NUMBERS ARE SHOWN FOR REFERENCE ONLY.
 7. DIMENSION A AND B ARE TO BE DETERMINED AT DATUM PLANE -W-.

DIM	MILLIMETERS		INCHES	
	MIN	MAX	MIN	MAX
A	6.40	6.60	0.252	0.260
B	4.30	4.50	0.169	0.177
C	---	1.20	---	0.047
D	0.05	0.15	0.002	0.006
F	0.50	0.75	0.020	0.030
G	0.65 BSC		0.026 BSC	
H	0.27	0.37	0.011	0.015
J	0.09	0.20	0.004	0.008
J1	0.09	0.16	0.004	0.006
K	0.19	0.30	0.007	0.012
K1	0.19	0.25	0.007	0.010
L	6.40 BSC		0.252 BSC	
M	0°	8°	0°	8°

DTB SUFFIX
CASE 948F-01
 Plastic Package
 (TSSOP-16, TSSOP-16L)
 ISSUE O

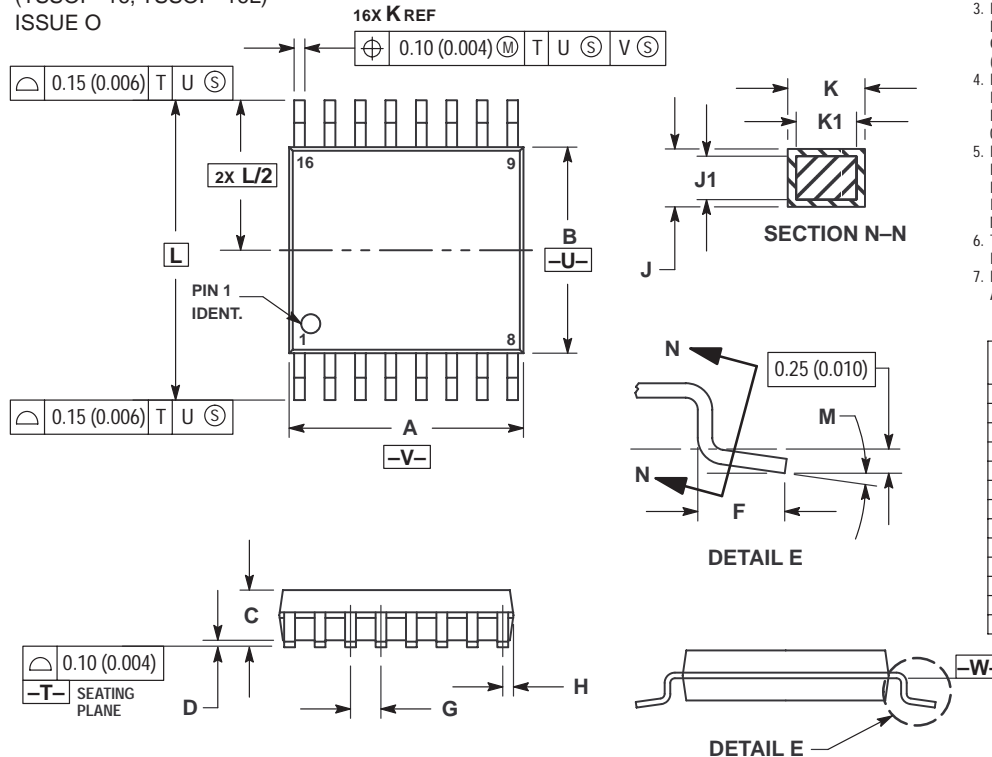
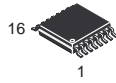

- NOTES:
1. DIMENSIONING AND TOLERANCING PER ANSI Y14.5M, 1982.
 2. CONTROLLING DIMENSION: MILLIMETER.
 3. DIMENSION A DOES NOT INCLUDE MOLD FLASH, PROTRUSIONS OR GATE BURRS. MOLD FLASH OR GATE BURRS SHALL NOT EXCEED 0.15 (0.006) PER SIDE.
 4. DIMENSION B DOES NOT INCLUDE INTERLEAD FLASH OR PROTRUSION. INTERLEAD FLASH OR PROTRUSION SHALL NOT EXCEED 0.25 (0.010) PER SIDE.
 5. DIMENSION K DOES NOT INCLUDE DAMBAR PROTRUSION. ALLOWABLE DAMBAR PROTRUSION SHALL BE 0.08 (0.003) TOTAL IN EXCESS OF THE K DIMENSION AT MAXIMUM MATERIAL CONDITION.
 6. TERMINAL NUMBERS ARE SHOWN FOR REFERENCE ONLY.
 7. DIMENSION A AND B ARE TO BE DETERMINED AT DATUM PLANE -W-.

DIM	MILLIMETERS		INCHES	
	MIN	MAX	MIN	MAX
A	4.90	5.10	0.193	0.200
B	4.30	4.50	0.169	0.177
C	---	1.20	---	0.047
D	0.05	0.15	0.002	0.006
F	0.50	0.75	0.020	0.030
G	0.65 BSC		0.026 BSC	
H	0.18	0.28	0.007	0.011
J	0.09	0.20	0.004	0.008
J1	0.09	0.16	0.004	0.006
K	0.19	0.30	0.007	0.012
K1	0.19	0.25	0.007	0.010
L	6.40 BSC		0.252 BSC	
M	0°	8°	0°	8°

DTB SUFFIX
CASE 948G-01
 Plastic Package
 (TSSOP-14)
 ISSUE O

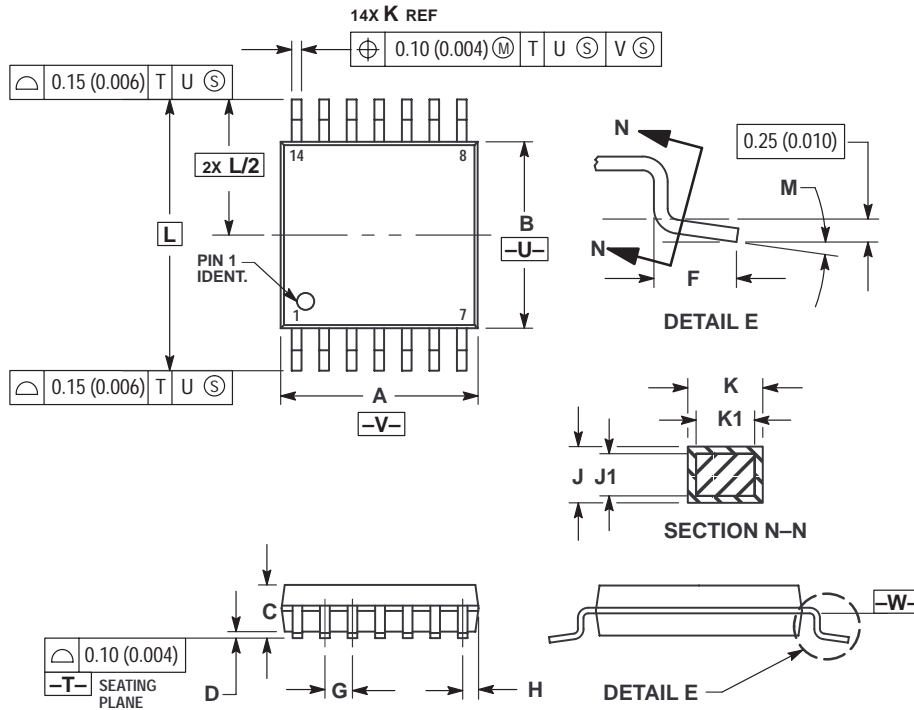

NOTES:

- 1 DIMENSIONING AND TOLERANCING PER ANSI Y14.5M, 1982.
- 2 CONTROLLING DIMENSION: MILLIMETER.
- 3 DIMENSION A DOES NOT INCLUDE MOLD FLASH, PROTRUSIONS OR GATE BURRS. MOLD FLASH OR GATE BURRS SHALL NOT EXCEED 0.15 (0.006) PER SIDE.
- 4 DIMENSION B DOES NOT INCLUDE INTERLEAD FLASH OR PROTRUSION. INTERLEAD FLASH OR PROTRUSION SHALL NOT EXCEED 0.25 (0.010) PER SIDE.
- 5 DIMENSION K DOES NOT INCLUDE DAMBAR PROTRUSION. ALLOWABLE DAMBAR PROTRUSION SHALL BE 0.08 (0.003) TOTAL IN EXCESS OF THE K DIMENSION AT MAXIMUM MATERIAL CONDITION.
- 6 TERMINAL NUMBERS ARE SHOWN FOR REFERENCE ONLY.
- 7 DIMENSION A AND B ARE TO BE DETERMINED AT DATUM PLANE -W-.

DIM	MILLIMETERS		INCHES	
	MIN	MAX	MIN	MAX
A	4.90	5.10	0.193	0.200
B	4.30	4.50	0.169	0.177
C	---	1.20	---	0.047
D	0.05	0.15	0.002	0.006
F	0.50	0.75	0.020	0.030
G	0.65 BSC		0.026 BSC	
H	0.50	0.60	0.020	0.024
J	0.09	0.20	0.004	0.008
J1	0.09	0.16	0.004	0.006
K	0.19	0.30	0.007	0.012
K1	0.19	0.25	0.007	0.010
L	6.40 BSC		0.252 BSC	
M	0°	8°	0°	8°

DTB SUFFIX
CASE 948H-01
 Plastic Package
 ISSUE O

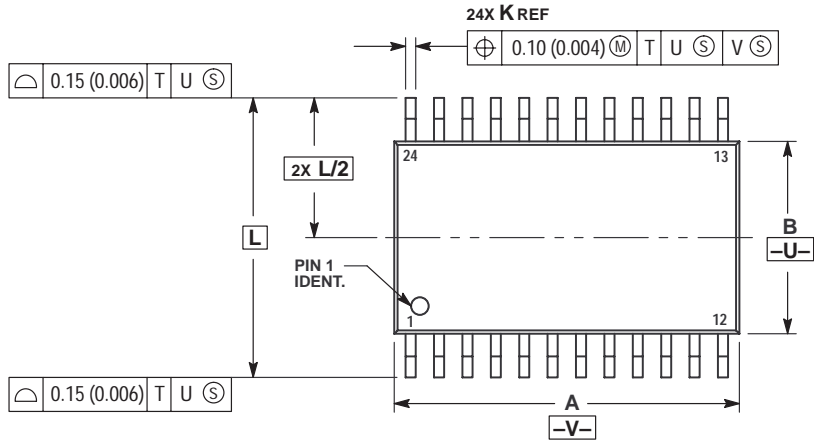
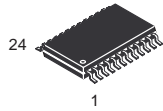

- NOTES:
1. DIMENSIONING AND TOLERANCING PER ANSI Y14.5M, 1982.
 2. CONTROLLING DIMENSION: MILLIMETER.
 3. DIMENSION A DOES NOT INCLUDE MOLD FLASH, PROTRUSIONS OR GATE BURRS. MOLD FLASH OR GATE BURRS SHALL NOT EXCEED 0.15 (0.006) PER SIDE.
 4. DIMENSION B DOES NOT INCLUDE INTERLEAD FLASH OR PROTRUSION. INTERLEAD FLASH OR PROTRUSION SHALL NOT EXCEED 0.25 (0.010) PER SIDE.
 5. DIMENSION K DOES NOT INCLUDE DAMBAR PROTRUSION. ALLOWABLE DAMBAR PROTRUSION SHALL BE 0.08 (0.003) TOTAL IN EXCESS OF THE K DIMENSION AT MAXIMUM MATERIAL CONDITION.
 6. TERMINAL NUMBERS ARE SHOWN FOR REFERENCE ONLY.
 7. DIMENSION A AND B ARE TO BE DETERMINED AT DATUM PLANE -W-.

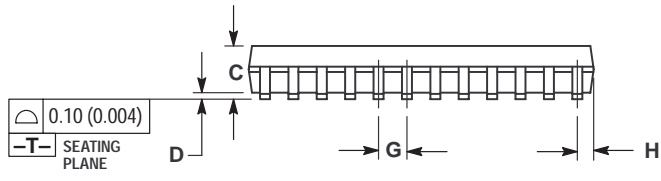

DIM	MILLIMETERS		INCHES	
	MIN	MAX	MIN	MAX
A	7.70	7.90	0.303	0.311
B	4.30	4.50	0.169	0.177
C	---	1.20	---	0.047
D	0.05	0.15	0.002	0.006
F	0.50	0.75	0.020	0.030
G	0.65 BSC		0.026 BSC	
H	0.27	0.37	0.011	0.015
J	0.09	0.20	0.004	0.008
J1	0.09	0.16	0.004	0.006
K	0.19	0.30	0.007	0.012
K1	0.19	0.25	0.007	0.010
L	6.40 BSC		0.252 BSC	
M	0°	8°	0°	8°

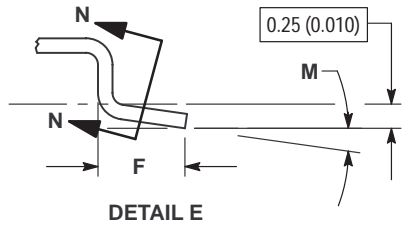
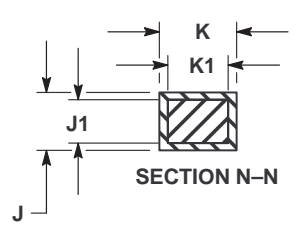
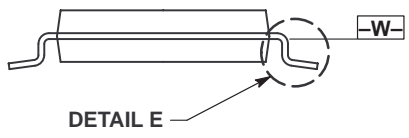

DTB SUFFIX
CASE 948J-01
 Plastic Package
 (TSSOP-8)
 ISSUE O

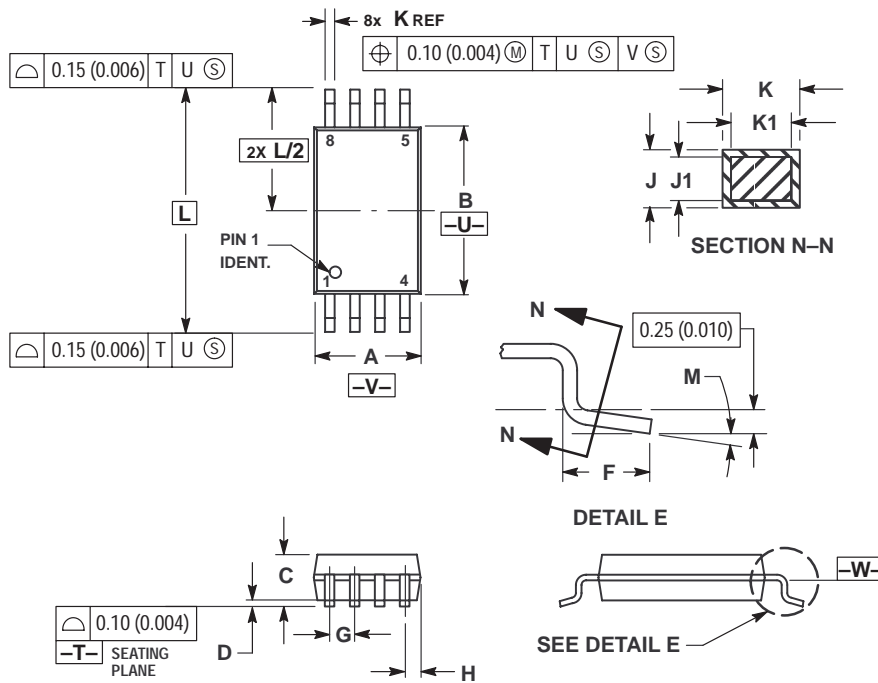

- NOTES:
- 1 DIMENSIONING AND TOLERANCING PER ANSI Y14.5M, 1982.
 - 2 CONTROLLING DIMENSION: MILLIMETER.
 - 3 DIMENSION A DOES NOT INCLUDE MOLD FLASH, PROTRUSIONS OR GATE BURRS. MOLD FLASH OR GATE BURRS SHALL NOT EXCEED 0.15 (0.006) PER SIDE.
 - 4 DIMENSION B DOES NOT INCLUDE INTERLEAD FLASH OR PROTRUSION. INTERLEAD FLASH OR PROTRUSION SHALL NOT EXCEED 0.25 (0.010) PER SIDE.
 - 5 DIMENSION K DOES NOT INCLUDE DAMBAR PROTRUSION. ALLOWABLE DAMBAR PROTRUSION SHALL BE 0.08 (0.003) TOTAL IN EXCESS OF THE K DIMENSION AT MAXIMUM MATERIAL CONDITION.
 - 6 TERMINAL NUMBERS ARE SHOWN FOR REFERENCE ONLY.
 - 7 DIMENSION A AND B ARE TO BE DETERMINED AT DATUM PLANE -W-.

DIM	MILLIMETERS		INCHES	
	MIN	MAX	MIN	MAX
A	2.90	3.10	0.114	0.122
B	4.30	4.50	0.169	0.177
C	---	1.20	---	0.047
D	0.05	0.15	0.002	0.006
F	0.50	0.75	0.020	0.030
G	0.65 BSC		0.026 BSC	
H	0.50	0.60	0.020	0.024
J	0.09	0.20	0.004	0.008
J1	0.09	0.16	0.004	0.006
K	0.19	0.30	0.007	0.012
K1	0.19	0.25	0.007	0.010
L	6.40 BSC		0.252 BSC	
M	0°	8°	0°	8°

M SUFFIX
CASE 967-01
 Plastic Package
 (EIAJ-20)
 ISSUE O

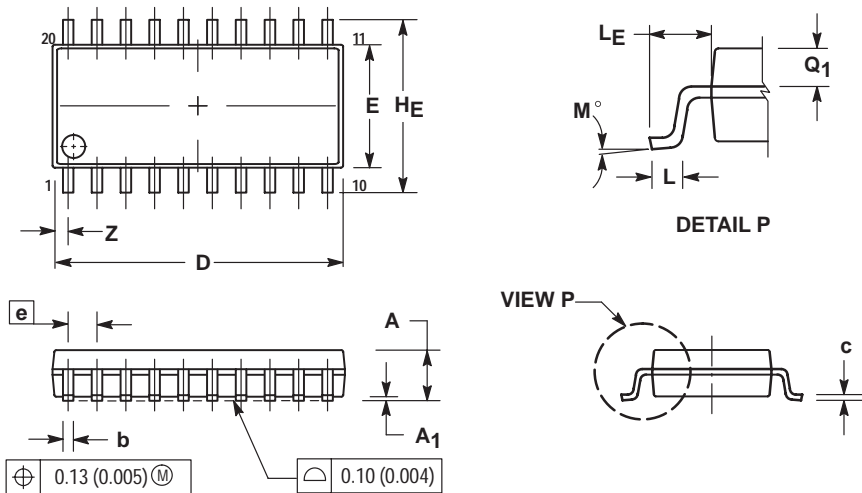
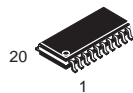

- NOTES:
- 1 DIMENSIONING AND TOLERANCING PER ANSI Y14.5M, 1982.
 - 2 CONTROLLING DIMENSION: MILLIMETER.
 - 3 DIMENSIONS D AND E DO NOT INCLUDE MOLD FLASH OR PROTRUSIONS AND ARE MEASURED AT THE PARTING LINE. MOLD FLASH OR PROTRUSIONS SHALL NOT EXCEED 0.15 (0.006) PER SIDE.
 - 4 TERMINAL NUMBERS ARE SHOWN FOR REFERENCE ONLY.
 - 5 THE LEAD WIDTH DIMENSION (b) DOES NOT INCLUDE DAMBAR PROTRUSION. ALLOWABLE DAMBAR PROTRUSION SHALL BE 0.08 (0.003) TOTAL IN EXCESS OF THE LEAD WIDTH DIMENSION AT MAXIMUM MATERIAL CONDITION. DAMBAR CANNOT BE LOCATED ON THE LOWER RADIUS OR THE FOOT. MINIMUM SPACE BETWEEN PROTRUSIONS AND ADJACENT LEAD TO BE 0.46 (0.018).

DIM	MILLIMETERS		INCHES	
	MIN	MAX	MIN	MAX
A	---	2.05	---	0.081
A1	0.05	0.20	0.002	0.008
b	0.35	0.50	0.014	0.020
c	0.18	0.27	0.007	0.011
D	12.35	12.80	0.486	0.504
E	5.10	5.45	0.201	0.215
e	1.27 BSC		0.050 BSC	
HE	7.40	8.20	0.291	0.323
L	0.50	0.85	0.020	0.033
LE	1.10	1.50	0.043	0.059
M	0°	10°	0°	10°
Q1	0.70	0.90	0.028	0.035
Z	---	0.81	---	0.032

FTB SUFFIX
CASE 976-01
Plastic Package
(TQFP-20)
ISSUE O

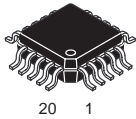

20 1

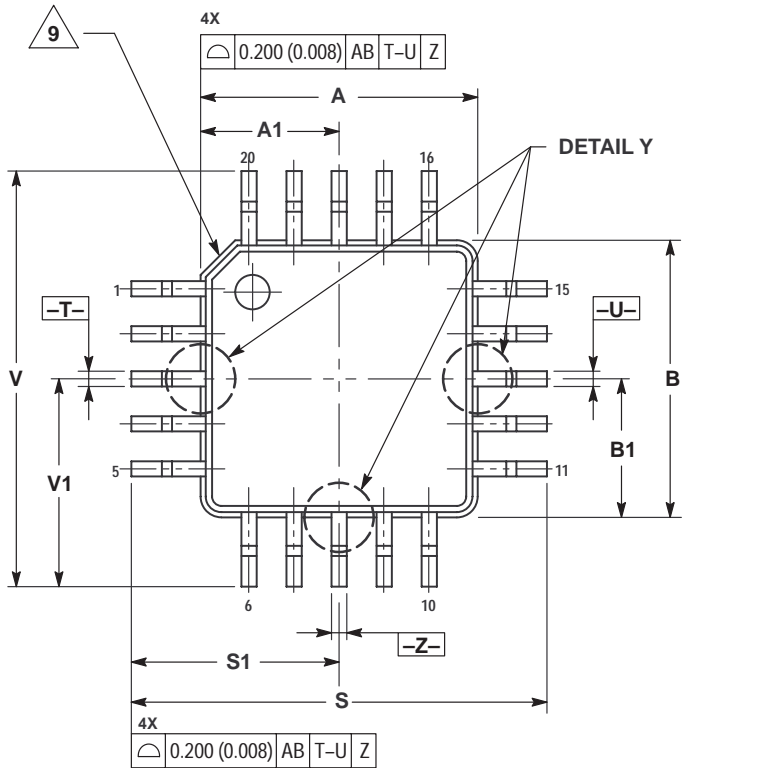

- NOTES:
1. DIMENSIONING AND TOLERANCING PER ANSI Y14.5M, 1982.
 2. CONTROLLING DIMENSION: MILLIMETER.
 3. DATUM PLANE -AB- IS LOCATED AT BOTTOM OF LEAD AND IS COINCIDENT WITH THE LEAD WHERE THE LEAD EXITS THE PLASTIC BODY AT THE BOTTOM OF THE PARTING LINE.
 4. DATUMS -T-, -U-, AND -Z- TO BE DETERMINED AT DATUM PLANE -AB-.
 5. DIMENSIONS S AND V TO BE DETERMINED AT DATUM PLANE -AC-.
 6. DIMENSIONS A AND B DO NOT INCLUDE MOLD PROTRUSION. ALLOWABLE PROTRUSION IS 0.250 (0.010) PER SIDE. DIMENSIONS A AND B DO INCLUDE MOLD MISMATCH AND ARE DETERMINED AT DATUM PLANE -AB-.
 7. DIMENSION D DOES NOT INCLUDE DAMBAR PROTRUSION. DAMBAR PROTRUSION SHALL NOT CAUSE THE D DIMENSION TO EXCEED 0.350 (0.014).
 8. MINIMUM SOLDER PLATE THICKNESS SHALL BE 0.0076 (0.0003).
 9. EXACT SHAPE OF EACH CORNER IS OPTIONAL.

DIM	MILLIMETERS		INCHES	
	MIN	MAX	MIN	MAX
A	4.000	BSC	0.157	BSC
A1	2.000	BSC	0.079	BSC
B	4.000	BSC	0.157	BSC
B1	2.000	BSC	0.079	BSC
C	1.400	1.600	0.055	0.063
D	0.170	0.270	0.007	0.011
E	1.350	1.450	0.053	0.057
F	0.170	0.230	0.007	0.009
G	0.650	BSC	0.026	BSC
H	0.050	0.150	0.002	0.006
J	0.090	0.200	0.004	0.008
K	0.500	0.700	0.020	0.028
M	12°	REF	12°	REF
N	0.090	0.160	0.004	0.006
P	0.250	BSC	0.010	BSC
Q	1°	5°	1°	5°
R	0.150	0.250	0.006	0.010
S	6.000	BSC	0.236	BSC
S1	3.000	BSC	0.118	BSC
V	6.000	BSC	0.236	BSC
V1	3.000	BSC	0.118	BSC
W	0.200	REF	0.008	REF
X	1.000	REF	0.039	REF

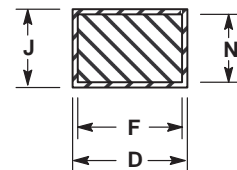
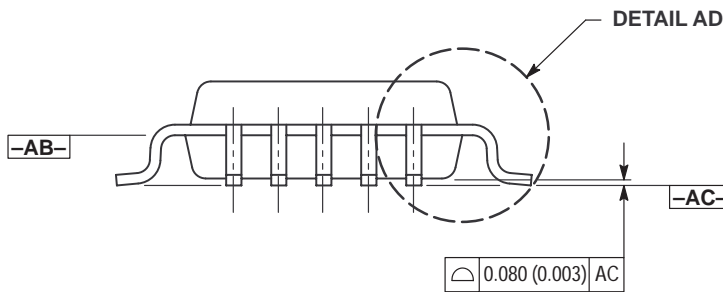

SECTION AE-AE

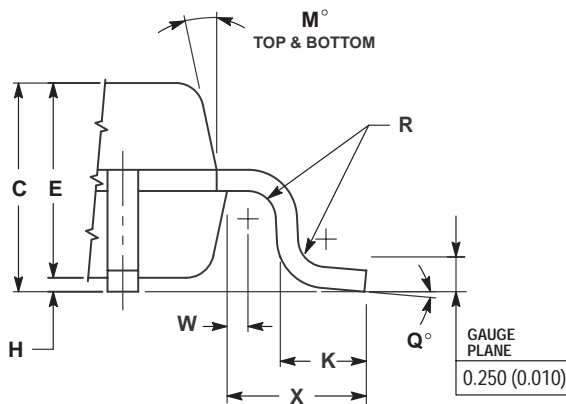

DETAIL AD

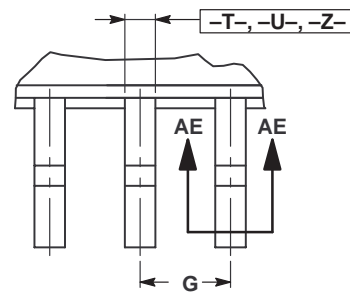

DETAIL Y

FTA SUFFIX
CASE 977-01
Plastic Package
ISSUE O

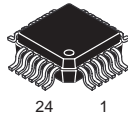

24 1

- NOTES:
1. DIMENSIONING AND TOLERANCING PER ANSI Y14.5M, 1982.
 2. CONTROLLING DIMENSION: MILLIMETER.
 3. DATUM PLANE -AB- IS LOCATED AT BOTTOM OF LEAD AND IS COINCIDENT WITH THE LEAD WHERE THE LEAD EXITS THE PLASTIC BODY AT THE BOTTOM OF THE PARTING LINE.
 4. DATUMS -T-, -U-, AND -Z- TO BE DETERMINED AT DATUM PLANE -AB-.
 5. DIMENSIONS S AND V TO BE DETERMINED AT DATUM PLANE -AC-.
 6. DIMENSIONS A AND B DO NOT INCLUDE MOLD PROTRUSION. ALLOWABLE PROTRUSION IS 0.250 (0.010) PER SIDE. DIMENSIONS A AND B DO INCLUDE MOLD MISMATCH AND ARE DETERMINED AT DATUM PLANE -AB-.
 7. DIMENSION D DOES NOT INCLUDE DAMBAR PROTRUSION. DAMBAR PROTRUSION SHALL NOT CAUSE THE D DIMENSION TO EXCEED 0.350 (0.014).
 8. MINIMUM SOLDER PLATE THICKNESS SHALL BE 0.0076 (0.0003).
 9. EXACT SHAPE OF EACH CORNER IS OPTIONAL.

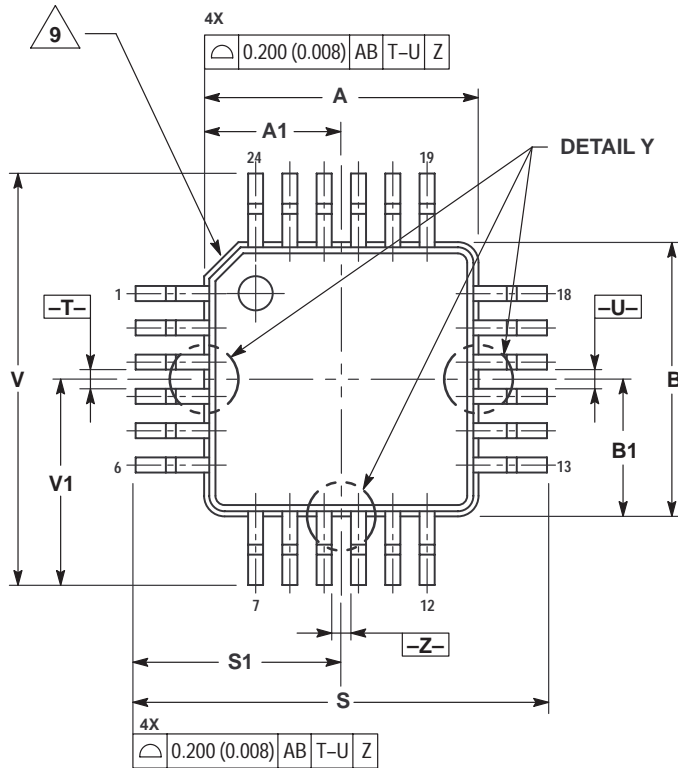

DIM	MILLIMETERS		INCHES	
	MIN	MAX	MIN	MAX
A	4.000 BSC		0.157 BSC	
A1	2.000 BSC		0.079 BSC	
B	4.000 BSC		0.157 BSC	
B1	2.000 BSC		0.079 BSC	
C	1.400	1.600	0.055	0.063
D	0.170	0.270	0.007	0.011
E	1.350	1.450	0.053	0.057
F	0.170	0.230	0.007	0.009
G	0.500 BSC		0.020 BSC	
H	0.050	0.150	0.002	0.006
J	0.090	0.200	0.004	0.008
K	0.500	0.700	0.020	0.028
M	12° REF		12° REF	
N	0.090	0.160	0.004	0.006
P	0.250 BSC		0.010 BSC	
Q	1°	5°	1°	5°
R	0.150	0.250	0.006	0.010
S	6.000 BSC		0.236 BSC	
S1	3.000 BSC		0.118 BSC	
V	6.000 BSC		0.236 BSC	
V1	3.000 BSC		0.118 BSC	
W	0.200 REF		0.008 REF	
X	1.000 REF		0.039 REF	

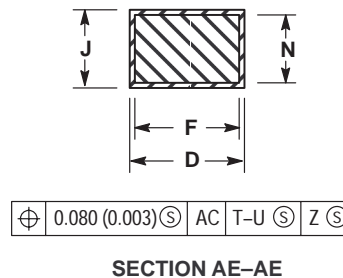
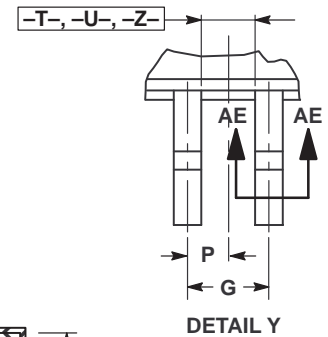
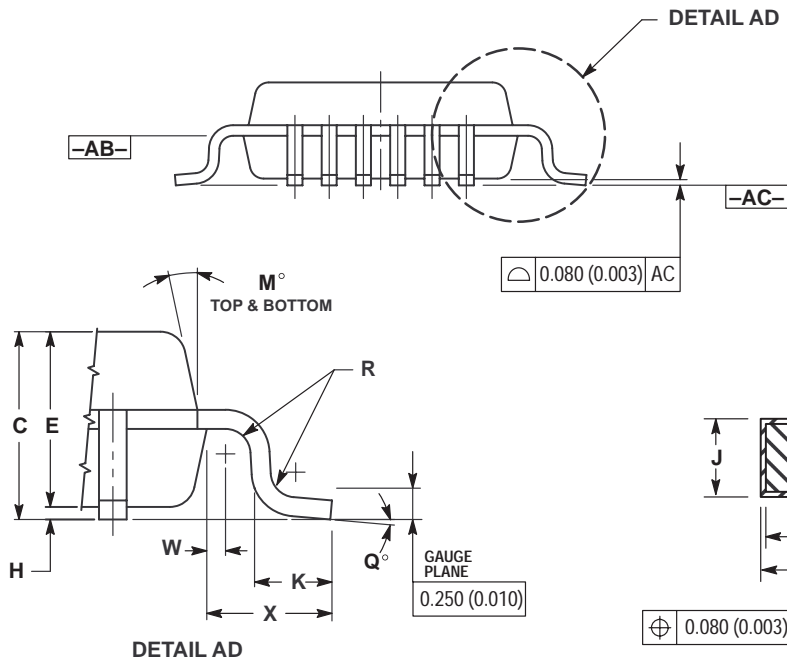

N SUFFIX
CASE 1212-01
 Plastic Package
 (SOT-23)
 ISSUE O

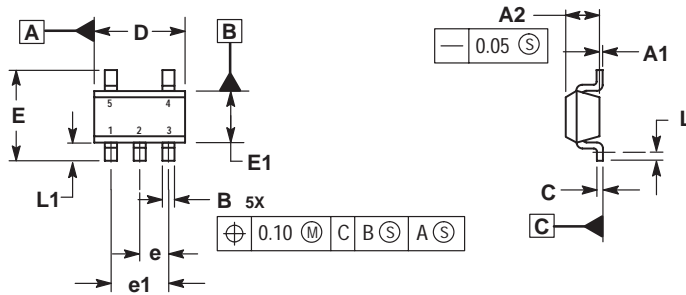

- NOTES:
 1. DIMENSIONS ARE IN MILLIMETERS.
 2. INTERPRET DIMENSIONS AND TOLERANCES PER ASME Y14.5M, 1994.
 3. DATUM C IS A SEATING PLANE.

MILLIMETERS		
DIM	MIN	MAX
A1	0.00	0.10
A2	1.00	1.30
B	0.30	0.50
C	0.10	0.25
D	2.80	3.00
E	2.50	3.10
E1	1.50	1.80
e	0.95 BSC	
e1	1.90 BSC	
L	0.20	----
L1	0.45	0.75

H SUFFIX
CASE 1213-01
 Plastic Package
 (SOT-89)
 ISSUE O

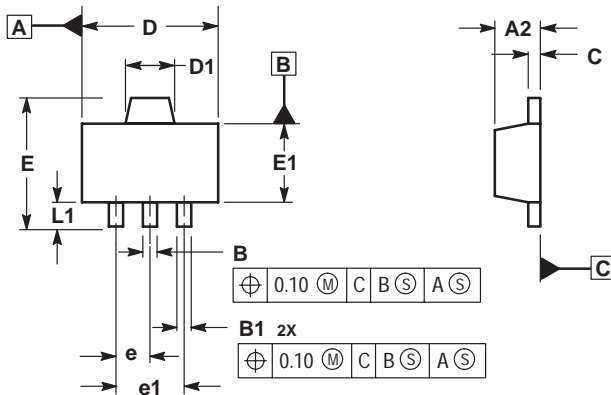

- NOTES:
 1. DIMENSIONS ARE IN MILLIMETERS.
 2. INTERPRET DIMENSIONS AND TOLERANCING PER ASME Y14.5M, 1994.
 3. DATUM C IS A SEATING PLANE.

MILLIMETERS		
DIM	MIN	MAX
A2	1.40	1.60
B	0.37	0.57
B1	0.32	0.52
C	0.30	0.50
D	4.40	4.60
D1	1.50	1.70
E	----	4.25
E1	2.40	2.60
e	1.50 BSC	
e1	3.00 BSC	
L1	0.80	----