

DUAL TRIP TEMPERATURE SWITCH IC (THERMOSTAT IC)

www.sii-ic.com

© Seiko Instruments Inc., 2008-2013

Rev.2.2_00

The S-5842A Series is a dual trip temperature switch IC (thermostat IC) which detects two points of temperature. The S-5842A Series operates at the power supply voltage of 2.5 V and the lower current consumption of 10 μ A typ. A temperature sensor with the negative temperature coefficient, a reference voltage generation circuit, a comparator and a delay circuit are integrated on one chip, and enclosed into the packages SOT-23-6 and SNT-6A.

■ Features

- | | |
|--|---|
| • Detection temperature: | Detection temperature = -10°C to $+110^{\circ}\text{C}$, $+1^{\circ}\text{C}$ step |
| • Accuracy of detection temperature: | $\pm 2.5^{\circ}\text{C}$ (Only for either detection temperature) |
| • Low voltage operation: | $V_{\text{DD}} = 2.5 \text{ V min.}$ (Detection temperature = $+20^{\circ}\text{C}$ to $+110^{\circ}\text{C}$)
$V_{\text{DD}} = 2.7 \text{ V min.}$ (Detection temperature = 0°C to $+110^{\circ}\text{C}$)
$V_{\text{DD}} = 2.8 \text{ V min.}$ (Detection temperature = -10°C to $+110^{\circ}\text{C}$) |
| • Low current consumption: | $I_{\text{DD}} = 10 \mu\text{A typ.}$ ($T_a = +25^{\circ}\text{C}$) |
| • Selectable output form: | CMOS output, Nch open-drain output |
| • Selectable output type: | Separate, Integrate |
| • Selectable output logic: | "H", "L" |
| • Operation temperature range: | $T_a = -40^{\circ}\text{C}$ to $+125^{\circ}\text{C}$ |
| • Lead-free, Sn 100%, halogen-free ^{*1} | |

*1. Refer to "■ Product Name Structure" for details.

■ Applications

- Fan control
- Air-conditioning system
- Mobile phone
- Game console
- Various electronics devices

■ Packages

- SOT-23-6
- SNT-6A

■ Block Diagrams

1. CMOS output product (Output type: Separate)

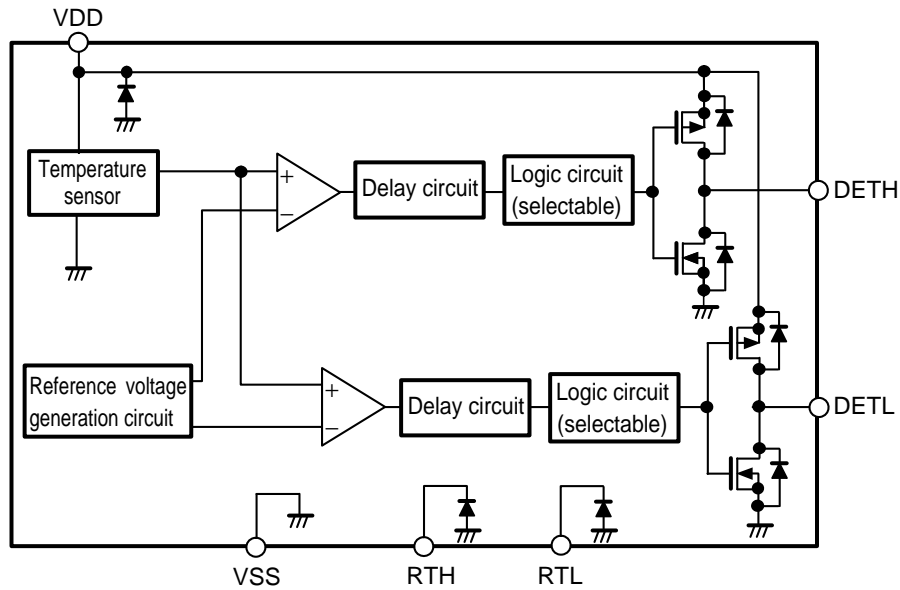

Figure 1

2. Nch open-drain output product (Output type: Separate)

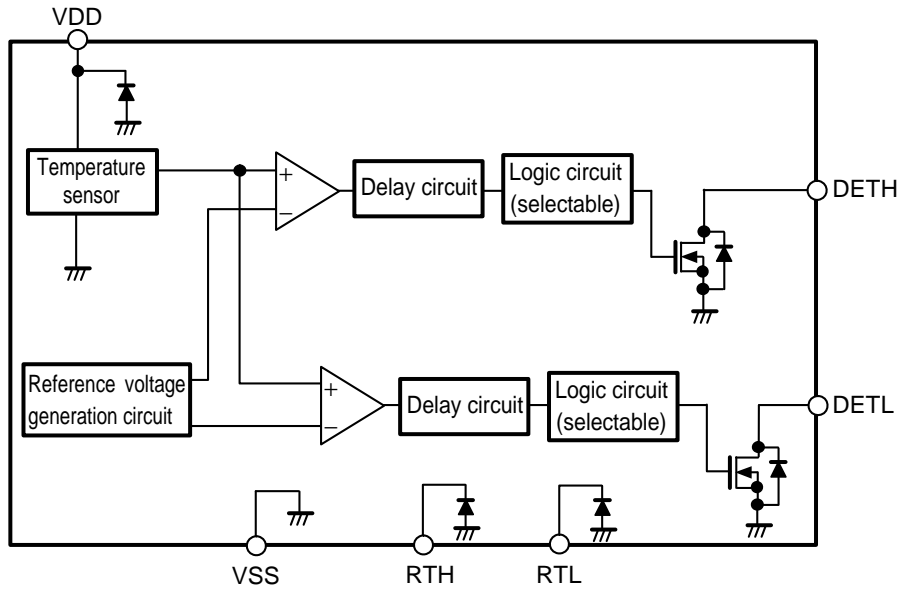

Figure 2

3. CMOS output product (Output type: Integrate)

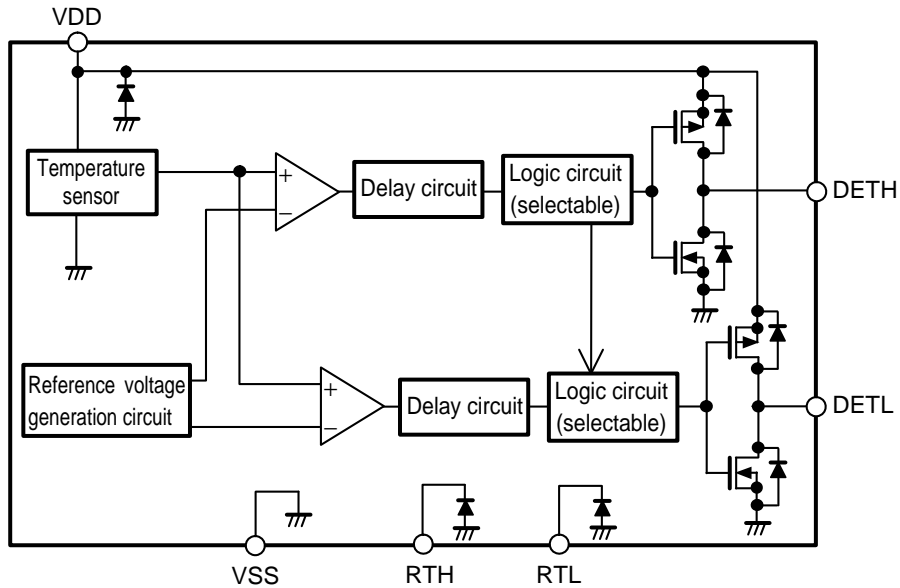

Figure 3

4. Nch open-drain output product (Output type: Integrate)

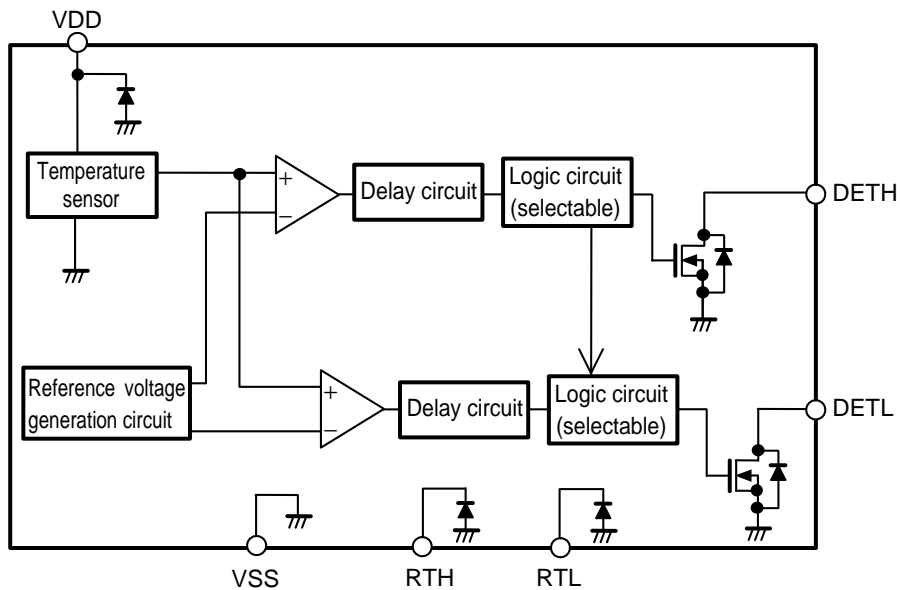

Figure 4

■ **Product Name Structure**

Users are able to select the output form and type, option for detection temperature's spec and package for the S-5842A Series.

1. Product name

1.1 SOT-23-6

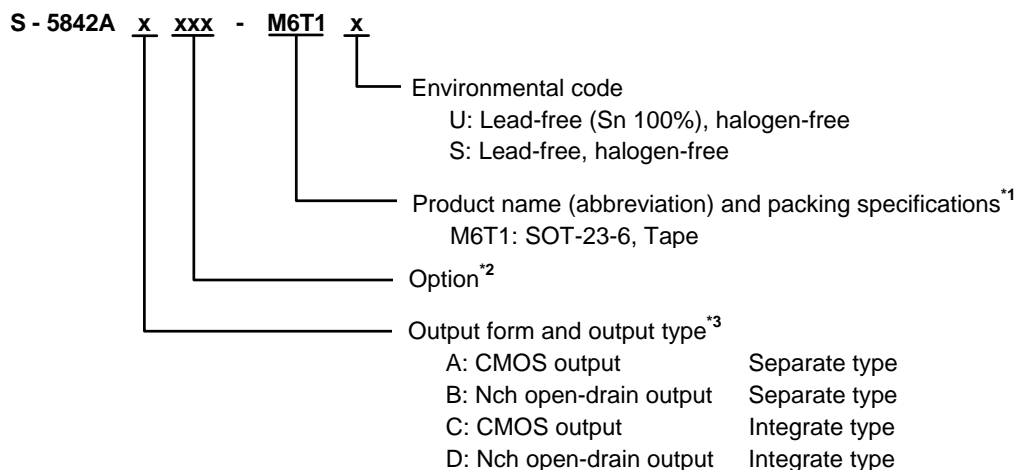

1.2 SNT-6A

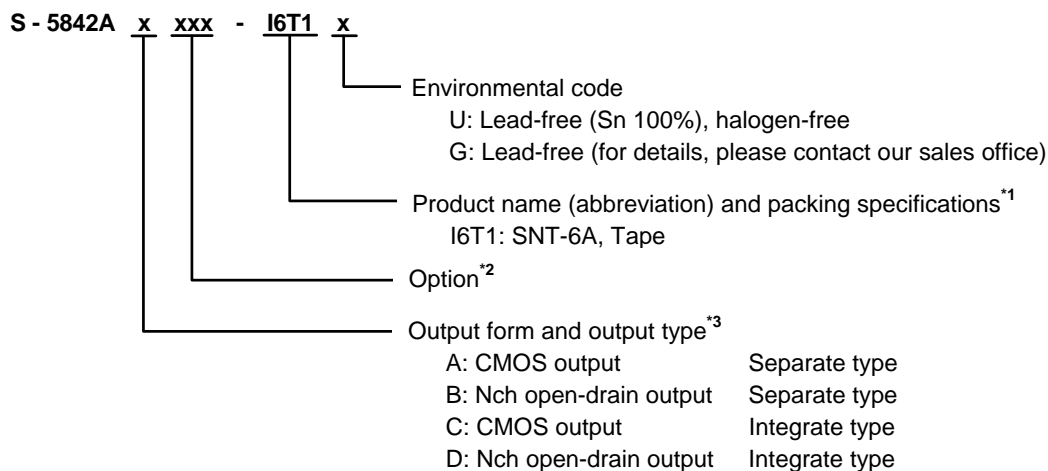

*1. Refer to the tape drawing.

*2. Refer to "■ Selection of Product Option". Settings are available in alphabetical order as AAA to ZZZ.

*3. Refer to "■ Selection of Product Option".

2. Packages

Table 1 Package Drawing Codes

Package Name	Dimension	Tape	Reel	Land
SOT-23-6	MP006-A-P-SD	MP006-A-C-SD	MP006-A-R-SD	—
SNT-6A	PG006-A-P-SD	PG006-A-C-SD	PG006-A-R-SD	PG006-A-L-SD

DUAL TRIP TEMPERATURE SWITCH IC IC (THERMOSTAT IC)

Rev.2.2_00

S-5842A Series

3. Product name list

3.1 SOT-23-6

Table 2

Product Name	Output Form and Type	Option for Detection Temperature's Spec							
		DETH Pin (for Higher Temperature)				DETL Pin (for Lower Temperature)			
		Detection Temperature (T _{DH})	Accuracy of Detection Temperature ^{*1}	Hysteresis Temperature (T _{HYSH})	Output Logic	Detection Temperature (T _{DL})	Accuracy of Detection Temperature ^{*1}	Hysteresis Temperature (T _{HYSL})	Output Logic
S-5842AAAAF-M6T1y	CMOS, Separate	+95°C	–	–5°C	"L"	+55°C	±2.5°C	–5°C	"L"
S-5842AAAAG-M6T1y	CMOS, Separate	+60°C	–	–5°C	"H"	0°C	±2.5°C	+5°C	"L"
S-5842AAAAL-M6T1U	CMOS, Separate	+45°C	±2.5°C	–2°C	"H"	0°C	–	+2°C	"H"
S-5842AAAAN-M6T1y	CMOS, Separate	+50°C	–	–5°C	"L"	+40°C	±2.5°C	–5°C	"L"
S-5842ACAAM-M6T1y	CMOS, Integrate	+45°C	–	–2°C	"L"	0°C	±2.5°C	–2°C	"L"

*1 Either of two detection temperatures (T_{DH}, T_{DL}), an accuracy of ±2.5°C is set only for the one that user specifies a higher accuracy than the other (T_{DH}, T_{DL}).

Remark 1. Please contact our sales office for products other than those specified above. Refer to "■ Selection of Product Option" for details.

2. y: S or U

3. Please select products of environmental code = U for Sn 100%, halogen-free products.

3.2 SNT-6A

Table 3

Product Name	Output Form and Type	Option for Detection Temperature's Spec							
		DETH Pin (for Higher Temperature)				DETL Pin (for Lower Temperature)			
		Detection Temperature (T _{DH})	Accuracy of Detection Temperature *1	Hysteresis Temperature (T _{HYSH})	Output Logic	Detection Temperature (T _{DL})	Accuracy of Detection Temperature *1	Hysteresis Temperature (T _{HYSL})	Output Logic
S-5842AAAAL-I6T1x	CMOS, Separate	+45°C	±2.5°C	-2°C	"H"	0°C	-	+2°C	"H"
S-5842AAAAT-I6T1x	CMOS, Separate	+45°C	-	-2°C	"H"	0°C	±2.5°C	+2°C	"L"
S-5842ABAAA-I6T1x	Nch open-drain, Separate	+62°C	-	+2°C	"H"	-3°C	±2.5°C	-2°C	"L"
S-5842ABAAC-I6T1x	Nch open-drain, Separate	+60°C	-	-2°C	"H"	0°C	±2.5°C	+2°C	"L"
S-5842ABAAJ-I6T1x	Nch open-drain, Separate	+40°C	-	-2°C	"H"	+5°C	±2.5°C	+2°C	"L"
S-5842ABAAP-I6T1x	Nch open-drain, Separate	+70°C	-	-5°C	"L"	+50°C	±2.5°C	-5°C	"H"
S-5842ABA AV-I6T1U	Nch open-drain, Separate	+65°C	-	-5°C	"L"	+50°C	±2.5°C	-5°C	"L"
S-5842ABA AW-I6T1U	Nch open-drain, Separate	+62°C	-	-2°C	"H"	+2°C	±2.5°C	-2°C	"H"
S-5842ABA AX-I6T1U	Nch open-drain, Separate	+55°C	-	-5°C	"H"	-10°C	±2.5°C	+5°C	"L"
S-5842ACA AS-I6T1x	CMOS, Integrate	+45°C	-	-2°C	"L"	0°C	±2.5°C	+2°C	"L"
S-5842ADA AH-I6T1x	Nch open-drain, Integrate	+70°C	±2.5°C	-5°C	"L"	+5°C	-	-5°C	"H"
S-5842ADA AK-I6T1x	Nch open-drain, Integrate	+60°C	±2.5°C	-5°C	"L"	+5°C	-	-5°C	"H"
S-5842ADA AQ-I6T1x	Nch open-drain, Integrate	+60°C	-	-2°C	"H"	0°C	±2.5°C	+2°C	"L"

*1 Either of two detection temperatures (T_{DH}, T_{DL}), an accuracy of ±2.5°C is set only for the one that user specifies a higher accuracy than the other (T_{DH}, T_{DL}).

Remark 1. Please contact our sales office for products other than those specified above. Refer to "■ Selection of Product Option" for details.

2. x: G or U

3. Please select products of environmental code = U for Sn 100%, halogen-free products.

■ **Pin Configurations**

1. **SOT-23-6**

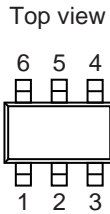

Figure 5

Table 4

Pin No.	Symbol	Description
1	VDD	Power supply pin
2	DETL	Output pin for lower temperature detection
3	RTL ^{*1}	TEST pin
4	RTH ^{*2}	TEST pin
5	VSS	GND pin
6	DETH	Output pin for higher temperature detection

*1. Set the RTL pin open in use.

*2. Set the RTH pin open in use.

2. **SNT-6A**

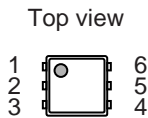

Figure 6

Table 5

Pin No.	Symbol	Description
1	DETH	Output pin for higher temperature detection
2	VSS	GND pin
3	RTH ^{*1}	TEST pin
4	RTL ^{*2}	TEST pin
5	DETL	Output pin for lower temperature detection
6	VDD	Power supply pin

*1. Set the RTH pin open in use.

*2. Set the RTL pin open in use.

■ Absolute Maximum Ratings

Table 6

(Ta = +25°C unless otherwise specified)

Item		Symbol	Absolute Maximum Rating	Unit
Power supply voltage ($V_{SS} = 0$ V)		V_{DD}	$V_{SS} + 6.5$	V
Pin voltage		V_{RTH}, V_{RTL}	$V_{SS} - 0.3$ to $V_{DD} + 0.3$	V
Output voltage	CMOS output product	V_{DETH}, V_{DETL}	$V_{SS} - 0.3$ to $V_{DD} + 0.3$	V
	Nch open-drain output product		$V_{SS} - 0.3$ to $V_{SS} + 6.5$	V
Output pin current		I_{OHH}, I_{OHL}	13	mA
		I_{OLH}, I_{OLL}	13	mA
Power dissipation	SOT-23-6	P_D	650^{*1}	mW
	SNT-6A		400^{*1}	mW
Operation ambient temperature		T_{opr}	-40 to +125	°C
Storage temperature		T_{stg}	-65 to +150	°C

*1. When mounted on board

[Mounted board]

- (1) Board size : 114.3 mm × 76.2 mm × t1.6 mm
- (2) Board name : JEDEC STANDARD51-7

Caution The absolute maximum ratings are rated values exceeding which the product could suffer physical damage. These values must therefore not be exceeded under any conditions.

■ **DC Electrical Characteristics**

1. **CMOS output product**

Table 7

(Ta = +25°C unless otherwise specified)

Item	Symbol	Condition	Min.	Typ.	Max.	Unit	Test Circuit
Power supply voltage	V _{DD}	Detection temperature = +20°C to +110°C	2.5	–	5.5	V	1
		Detection temperature = 0°C to +110°C	2.7	–	5.5	V	1
		Detection temperature = –10°C to +110°C	2.8	–	5.5	V	1
Detection temperature* ¹	T _{DH} or T _{DL}	–	T _{DET} – 2.5	T _{DET}	T _{DET} + 2.5	°C	1
Difference of detection temperature* ²	ΔT _D	V _{DD} = 3.5 V	–	ΔT _{DET}	–	°C	1
Hysteresis temperature of DETH pin* ³	T _{HYSH}	V _{DD} = 3.5 V	–	–5, –2, +2, +5	–	°C	1
Hysteresis temperature of DETL pin* ³	T _{HYSL}	V _{DD} = 3.5 V	–	–5, –2, +2, +5	–	°C	1
Output current "H" of DETH pin	I _{OHH}	V _{DD} = 3.5 V, V _{DETH} = 3.0 V	0.5	3.2	–	mA	2
Output current "H" of DETL pin	I _{OHL}	V _{DD} = 3.5 V, V _{DETL} = 3.0 V	0.5	3.2	–	mA	2
Output current "L" of DETH pin	I _{OLH}	V _{DD} = 3.5 V, V _{DETH} = 0.5 V	0.5	3.0	–	mA	2
Output current "L" of DETL pin	I _{OLL}	V _{DD} = 3.5 V, V _{DETL} = 0.5 V	0.5	3.0	–	mA	2
Current consumption during operation	I _{DD}	V _{DD} = 3.5 V	–	10	16	μA	1

- *1. T_{DET}: set value for detection temperature, T_{DH}: actual detection temperature for higher temperature, T_{DL}: actual detection temperature for lower temperature
 Either of two detection temperatures (T_{DH}, T_{DL}), an accuracy of ±2.5°C is set only for the one that user specifies a higher accuracy than the other (T_{DH}, T_{DL}).
- *2. ΔT_{DET}: set value for detection temperature for higher temperature – set value for detection temperature for lower temperature
 ΔT_D: actual difference of detection temperature
 Set two points of detection temperature so that the difference of detection temperature (ΔT_{DET}) is in 0°C to 65°C. Users are able to set ΔT_{DET} in 0°C, 5°C, 10°C ... 60°C, 65°C.
- *3. Users are able to select the hysteresis temperature in –5°C, –2°C, +2°C, or +5°C.

[Fahrenheit ↔ Celsius Conversion equation]

$$^{\circ}\text{C} = (^{\circ}\text{F} - 32) \times 5 / 9$$

$$^{\circ}\text{F} = 32 + ^{\circ}\text{C} \times 9 / 5$$

2. Nch open-drain output product

Table 8

(Ta = +25°C unless otherwise specified)

Item	Symbol	Condition	Min.	Typ.	Max.	Unit	Test Circuit
Power supply voltage	V _{DD}	Detection temperature = +20°C to +110°C	2.5	–	5.5	V	1
		Detection temperature = 0°C to +110°C	2.7	–	5.5	V	1
		Detection temperature = –10°C to +110°C	2.8	–	5.5	V	1
Detection temperature* ¹	T _{DH} or T _{DL}	–	T _{DET} – 2.5	T _{DET}	T _{DET} + 2.5	°C	1
Difference of detection temperature* ²	ΔT _D	V _{DD} = 3.5 V	–	ΔT _{DET}	–	°C	1
Hysteresis temperature of DETH pin* ³	T _{HYSH}	V _{DD} = 3.5 V	–	–5, –2, +2, +5	–	°C	1
Hysteresis temperature of DETL pin* ³	T _{HYSL}	V _{DD} = 3.5 V	–	–5, –2, +2, +5	–	°C	1
Leakage current of DETH pin	I _{LEAKH}	V _{DD} = 3.5 V, V _{DETH} = 5.5 V	–	–	100	nA	2
Leakage current of DETL pin	I _{LEAKL}	V _{DD} = 3.5 V, V _{DETL} = 5.5 V	–	–	100	nA	2
Output current "L" of DETH pin	I _{OLH}	V _{DD} = 3.5 V, V _{DETH} = 0.5 V	0.5	3.0	–	mA	2
Output current "L" of DETL pin	I _{OLL}	V _{DD} = 3.5 V, V _{DETL} = 0.5 V	0.5	3.0	–	mA	2
Current consumption during operation	I _{DD}	V _{DD} = 3.5 V	–	10	16	μA	1

- *1. T_{DET}: set value for detection temperature, T_{DH}: actual detection temperature for higher temperature, T_{DL}: actual detection temperature for lower temperature
 Either of two detection temperatures (T_{DH}, T_{DL}), an accuracy of ±2.5°C is set only for the one that user specifies a higher accuracy than the other (T_{DH}, T_{DL}).
- *2. ΔT_{DET}: set value for detection temperature for higher temperature – set value for detection temperature for lower temperature
 ΔT_D: actual difference of detection temperature
 Set two points of detection temperature so that the difference of detection temperature (ΔT_{DET}) is in 0°C to 65°C. Users are able to set ΔT_{DET} in 0°C, 5°C, 10°C ... 60°C, 65°C.
- *3. Users are able to select the hysteresis temperature in –5°C, –2°C, +2°C, or +5°C.

[Fahrenheit ↔ Celsius Conversion equation]

$$^{\circ}\text{C} = (^{\circ}\text{F} - 32) \times 5 / 9$$

$$^{\circ}\text{F} = 32 + ^{\circ}\text{C} \times 9 / 5$$

■ AC Electrical Characteristics

Table 9

Item	Symbol	Condition	Min.	Typ.	Max.	Unit	Test Circuit
Noise suppression time	t _{delay}	V _{DD} = 3.5 V, Ta = detection temperature	–	550	–	μs	–

■ Test Circuits

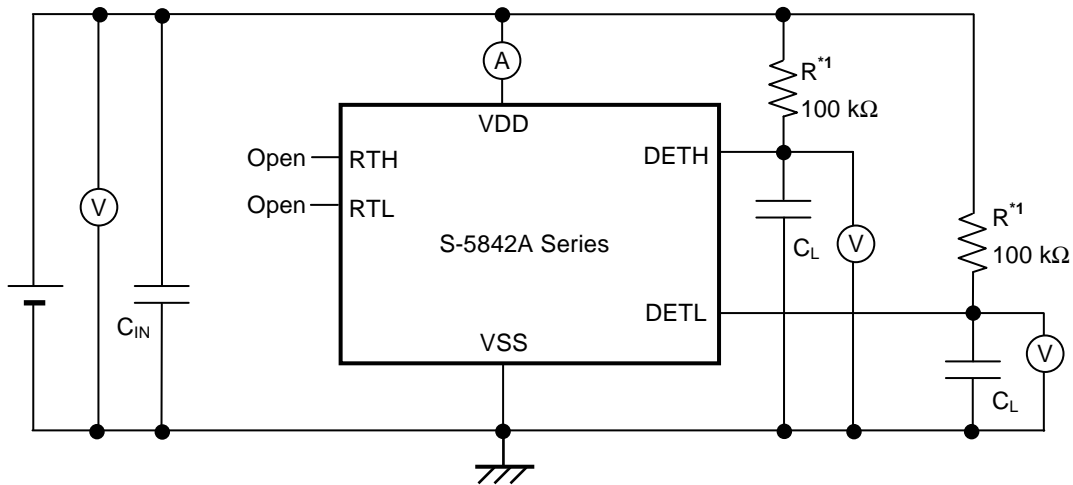

*1. Resistor (R) is unnecessary for the CMOS output product.

Figure 7 Test Circuit 1

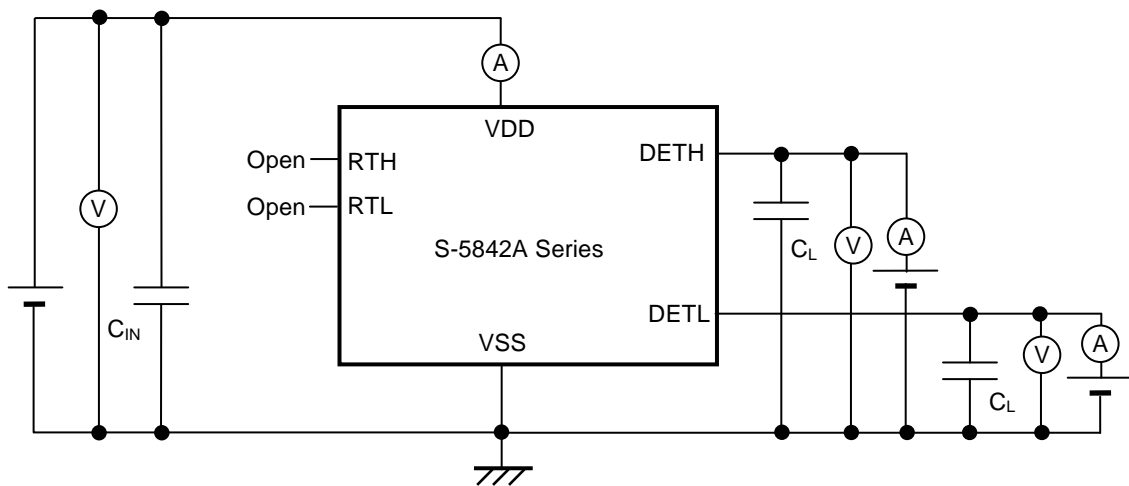

Figure 8 Test Circuit 2

■ Selection of Product Option

1. Description of product option

The S-5842A Series is a temperature switch IC (thermostat IC) which detects two points of temperature, and outputs a signal to the exterior.

Users are able to select the combination of output type, form and logic, two detection temperatures (T_{DH} , T_{DL}), and hysteresis temperature (T_{HYSH} , T_{HYSL}).

Output form: Set the output logic for each DETH pin and DETL pin.

- CMOS output
- Nch open-drain output

Output type: for DETH pin and DETL pin, users are able to select two types of output as follows.

- Separate type: The DETH pin's output inverts during detection of higher temperature
The DETL pin's output inverts during detection of lower temperature
- Integrate type: The DETH pin's output inverts during detection of higher temperature
The DETL pin's output inverts during detection of higher and lower temperature

Detection temperature (T_{DH} , T_{DL}):

T_{DH} is the detection temperature for higher temperature, T_{DL} is the detection temperature for lower temperature. Of two points of detection temperatures (T_{DH} , T_{DL}), select the detection temperature that is to be set the higher accuracy ($\pm 2.5^\circ\text{C}$ accuracy).^{*1}

- The detection temperature for higher temperature is selectable in $+20^\circ\text{C}$ to $+110^\circ\text{C}$, in 1°C step.
- The detection temperature for lower temperature is selectable in -10°C to $+110^\circ\text{C}$, in 1°C step.
- Set two points of detection temperature so that the difference of detection temperature (ΔT_{DET}) is in 0°C to 65°C . Users are able to set ΔT_{DET} in 0°C , 5°C , 10°C ... 60°C , 65°C .

The minimum operation voltage varies according to the detection temperature for lower temperature.

- Detection temperature = $+20^\circ\text{C}$ to $+110^\circ\text{C}$: $V_{DD} = 2.5 \text{ V min.}$
- Detection temperature = 0°C to $+110^\circ\text{C}$: $V_{DD} = 2.7 \text{ V min.}$
- Detection temperature = -10°C to $+110^\circ\text{C}$: $V_{DD} = 2.8 \text{ V min.}$

^{*1} Either of two detection temperatures (T_{DH} , T_{DL}), an accuracy of $\pm 2.5^\circ\text{C}$ is set only for the one that user specifies a higher accuracy than the other (T_{DH} , T_{DL}).

Hysteresis temperature (T_{HYSH} , T_{HYSL}):

T_{HYSH} is the hysteresis temperature for detection temperature for higher temperature, T_{HYSL} is the hysteresis temperature for detection temperature for lower temperature. These are selectable in -5°C , -2°C , $+2^\circ\text{C}$, or $+5^\circ\text{C}$.

- -5°C : Output recovers when temperature has dropped to 5°C from the detection temperature.
- -2°C : Output recovers when temperature has dropped to 2°C from the detection temperature.
- $+2^\circ\text{C}$: Output recovers when temperature has risen to 2°C from the detection temperature.
- $+5^\circ\text{C}$: Output recovers when temperature has risen to 5°C from the detection temperature.

Output logic: Set the output logic for each DETH, DETL pin in $T_a >$ detection temperature (T_{DH} , T_{DL}) or release temperature ($T_{DH} + T_{HYSH}$, $T_{DL} + T_{HYSL}$).

- (1) Hysteresis temperature: -5°C , -2°C
 - The output logic is "H" in $T_a >$ detection temperature
 - The output logic is "L" in $T_a >$ detection temperature
- (2) Hysteresis temperature: $+2^\circ\text{C}$, $+5^\circ\text{C}$
 - The output logic is "H" in $T_a >$ release temperature
 - The output logic is "L" in $T_a >$ release temperature

2. Example of product spec

Example of Product Spec	Operation
<p>Output form: CMOS output Output type: Separate type</p> <p>[DETH pin] Detection voltage: T_{DH} Hysteresis temperature: $T_{HYSH} (< 0)$ Output logic: "H"</p> <p>[DETL pin] Detection voltage: T_{DL} Hysteresis temperature: $T_{HYSL} (< 0)$ Output logic: "H"</p>	<p style="text-align: center;">Figure 9 Operation for CMOS Output and Separate Type</p>
<p>Output form: CMOS output Output type: Integrate type</p> <p>[DETH pin] Detection temperature: T_{DH} Hysteresis temperature: $T_{HYSH} (< 0)$ Output logic: "H"</p> <p>[DETL pin] Detection temperature: T_{DL} Hysteresis temperature: $T_{HYSL} (< 0)$ Output logic: "H"</p>	<p style="text-align: center;">Figure 10 Operation for CMOS Output and Integrate Type</p>

3. Delay circuit

The S-5842A Series sets the noise suppression time (t_{delay}) via the delay circuit. By this, the S-5842A Series prevents false detection operations of DETH pin and DETL pin output.

The followings are the operation of the DETH pin output when the output logic is "H".

3.1 The temperature is the detection temperature or less

The output from a comparator is "H", and the DETH pin output is "L". Due to noise or others, the output from a comparator is inverted to "L" once; however, the DETH pin output keeps "L" if this status is t_{delay} or shorter.

3.2 The temperature exceeds the detection temperature

The output from a comparator gets "L". And the DETH pin output gets "H" after the period has passed t_{delay} or longer.

■ Standard Circuit

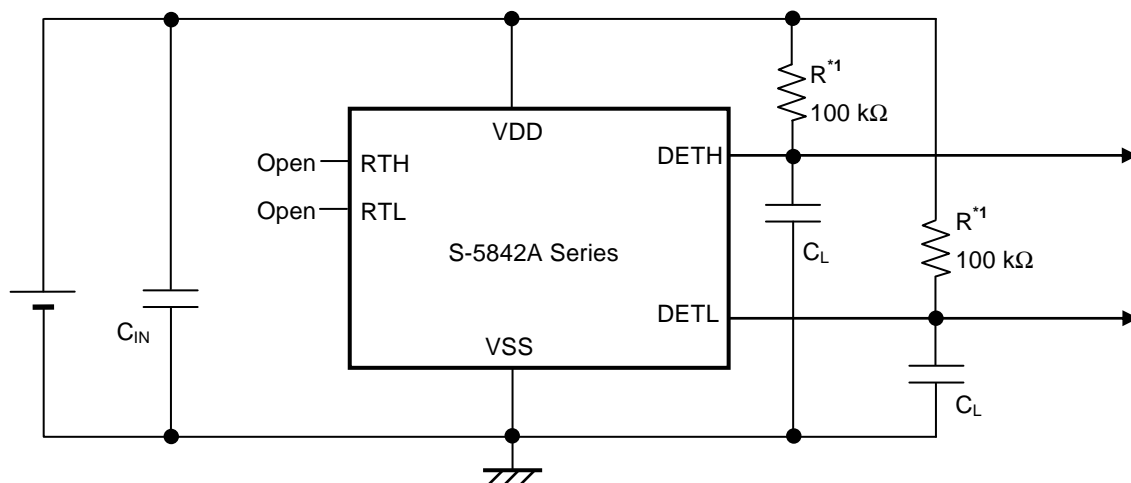

*1. Resistor (R) is unnecessary for CMOS output product.

Figure 13

Caution The above connection diagram will not guarantee successful operation. Perform thorough evaluation using actual application to set the constant.

■ Precautions

- Either of two detection temperatures (T_{DH} , T_{DL}), an accuracy of $\pm 2.5^{\circ}\text{C}$ is set only for the one that user specifies a higher accuracy than the other (T_{DH} , T_{DL}).
- Set a capacitor (C_{IN}) of 0.1 μF or more between the VDD pin and VSS pin for stabilization.
- To prevent error due to noise during power-on, set a capacitor (C_L) of approx. 0.1 μF for the DETH pin and the DETL pin.
- The S-5842A Series may oscillate by connecting a capacitor to the RTH pin and the RTL pin. Set the RTH pin and the RTL pin open in use.
- The DETH / DETL pin output a signal that of ($T_a >$ detection temperature) by short-circuit the RTH / RTL pin to VSS.
- Do not apply an electrostatic discharge to this IC that exceeds the performance ratings of the built-in electrostatic protection circuit.
- SII claims no responsibility for any disputes arising out of or in connection with any infringement by products, including this IC, of patents owned by a third party.

■ Characteristics (Typical Data)

1. Current consumption during operation vs. Power supply voltage characteristics

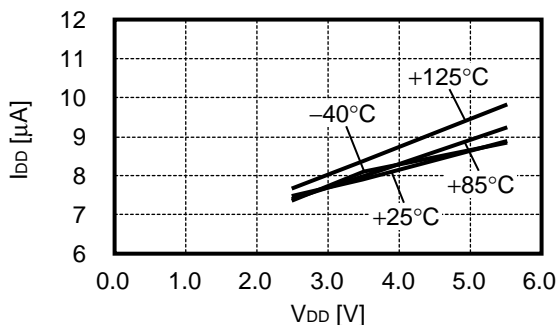

2. Output current "H" of DETH / DETL pin vs. Power supply voltage characteristics (CMOS output product only)

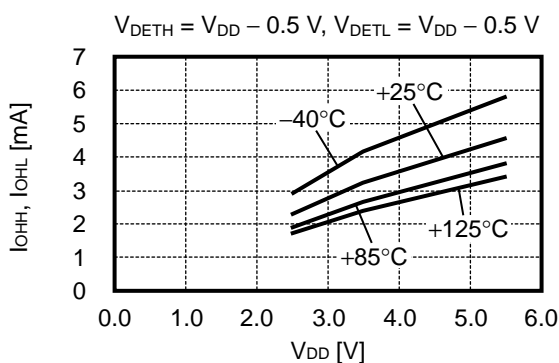

3. Output current "L" of DETH / DETL pin vs. Power supply voltage characteristics

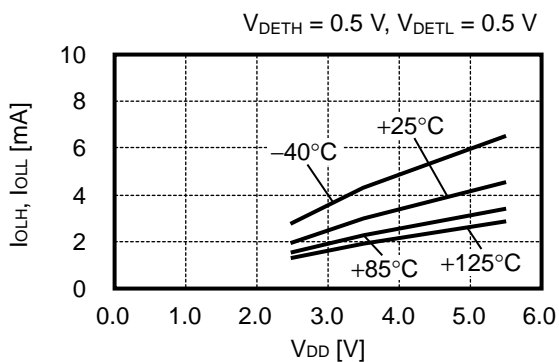

4. Noise suppression time vs. Power supply voltage characteristics

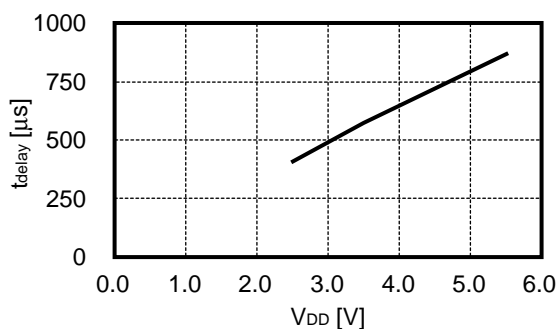

5. Response against heat (Output voltage vs. Time)

5.1 When SNT-6A is put into the air of +100°C from the air of +25°C at t = 0 s

$V_{DD} = 3.5\text{ V}$, $C_L = 0\ \mu\text{F}$, Detection temperature = +62°C, Output logic "H"

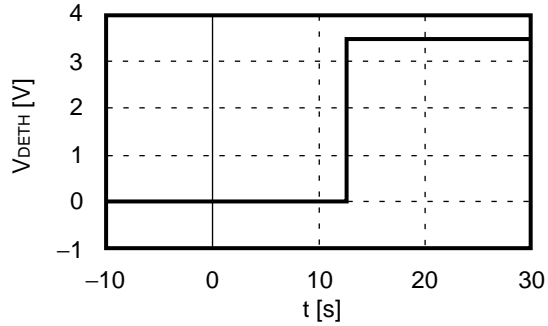

5.2 When SNT-6A is put into the liquid of +100°C from the air of +25°C at t = 0 s

$V_{DD} = 3.5\text{ V}$, $C_L = 0\ \mu\text{F}$, Detection temperature = +62°C, Output logic "H"

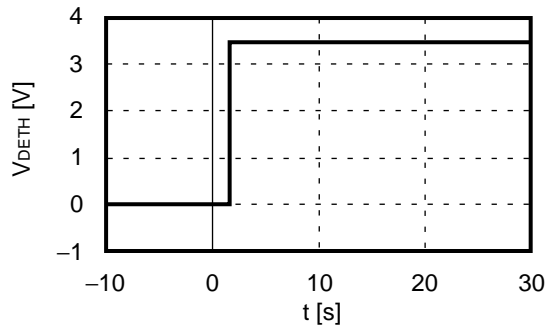

6. Response against startup

6.1 Power-on at Ta = +25°C

$T_{DH} = +110^{\circ}\text{C}$, $T_{DL} = +45^{\circ}\text{C}$, Output logic "H", $C_L = 0 \mu\text{F}$

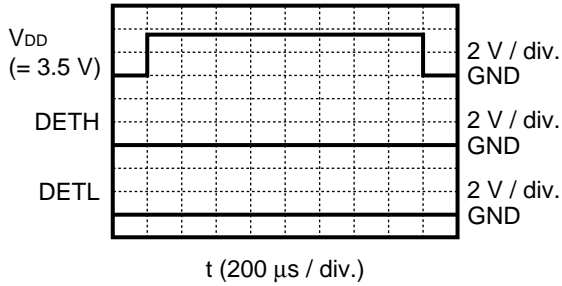

6.2 Power-on at Ta = +80°C

$T_{DH} = +110^{\circ}\text{C}$, $T_{DL} = +45^{\circ}\text{C}$, Output logic "H", $C_L = 0 \mu\text{F}$

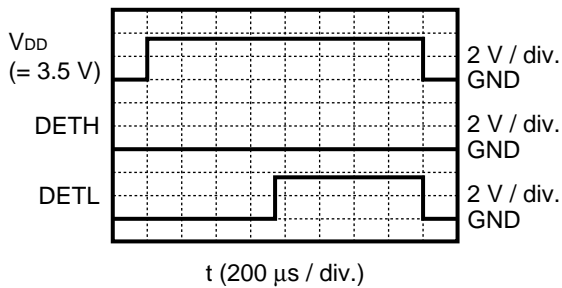

6.3 Power-on at Ta = +120°C

$T_{DH} = +110^{\circ}\text{C}$, $T_{DL} = +45^{\circ}\text{C}$, Output logic "H", $C_L = 0 \mu\text{F}$

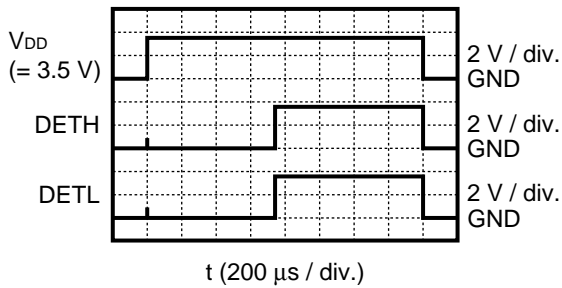

7. Accuracy of detection temperature

High accuracy detection voltage: T_{DH}

$T_{DH} = +110^{\circ}\text{C}$, $T_{DL} = +45^{\circ}\text{C}$

Measured data on one wafer picked up

7.1 Accuracy of detection temperature at $T_{DH} = +110^{\circ}\text{C}$ (Higher accuracy)

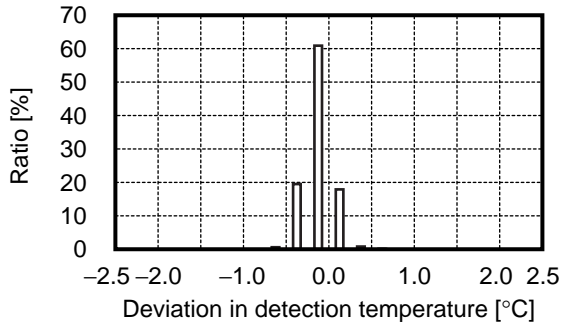

7.2 Accuracy of detection temperature at $T_{DL} = +45^{\circ}\text{C}$

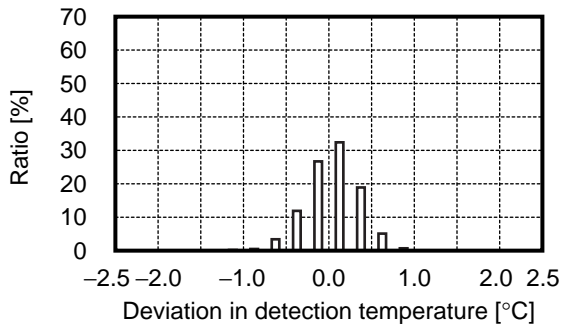

■ **Marking Specifications**

1. **SOT-23-6**

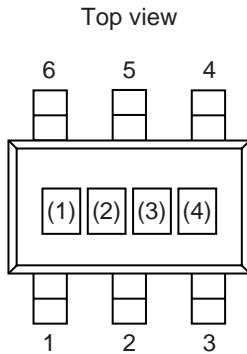

(1) to (3): Product code (Refer to **Product name vs. Product code**)
 (4): Lot number

Product name vs. Product code

Product Name	Product Code		
	(1)	(2)	(3)
S-5842AAAAF-M6T1y	U	I	F
S-5842AAAAG-M6T1y	U	I	G
S-5842AAAAL-M6T1U	U	I	L
S-5842AAAAN-M6T1y	U	I	N
S-5842ACAAM-M6T1y	U	J	M

- Remark 1.** Please contact our sales office for the products other than those specified above.
2. y: S or U
3. Please select products of environmental code = U for Sn 100%, halogen-free products.

2. SNT-6A

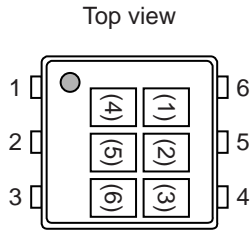

(1) to (3): Product code (Refer to **Product name vs. Product code**)
 (4) to (6): Lot number

Product name vs. Product code

Product Name	Product Code		
	(1)	(2)	(3)
S-5842AAAAL-I6T1x	U	I	L
S-5842AAAAT-I6T1x	U	I	T
S-5842ABAAA-I6T1x	U	H	A
S-5842ABAAC-I6T1x	U	H	C
S-5842ABAAJ-I6T1x	U	H	J
S-5842ABAAP-I6T1x	U	H	P
S-5842ABA AV-I6T1U	U	H	V
S-5842ABA AW-I6T1U	U	H	W
S-5842ABA AX-I6T1U	U	H	X
S-5842ACAAS-I6T1x	U	J	S
S-5842ADA AH-I6T1x	U	G	H
S-5842ADA AK-I6T1x	U	G	K
S-5842ADA AQ-I6T1x	U	G	Q

- Remark 1.** Please contact our sales office for the products other than those specified above.
2. x: G or U
3. Please select products of environmental code = U for Sn 100%, halogen-free products.

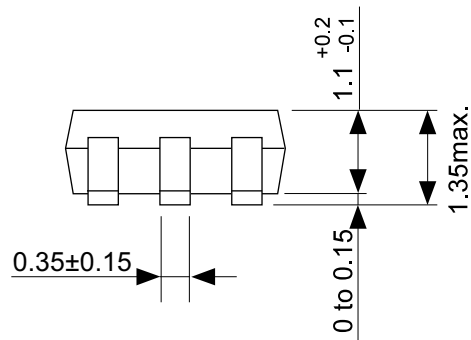
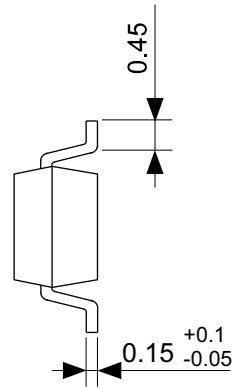
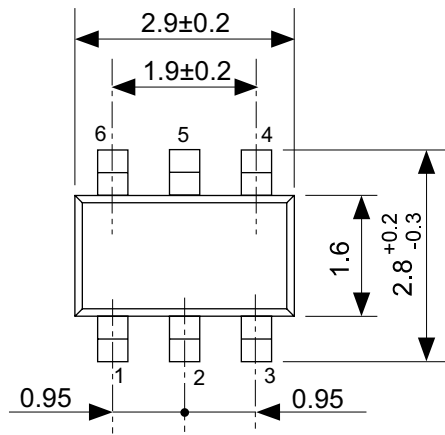

No. MP006-A-P-SD-2.0

TITLE	SOT236-A-PKG Dimensions
No.	MP006-A-P-SD-2.0
SCALE	
UNIT	mm
Seiko Instruments Inc.	

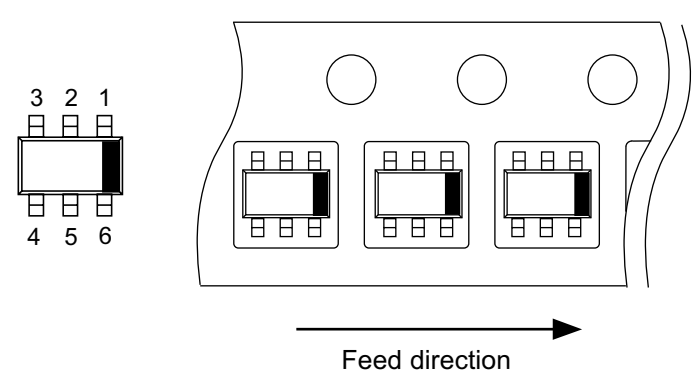
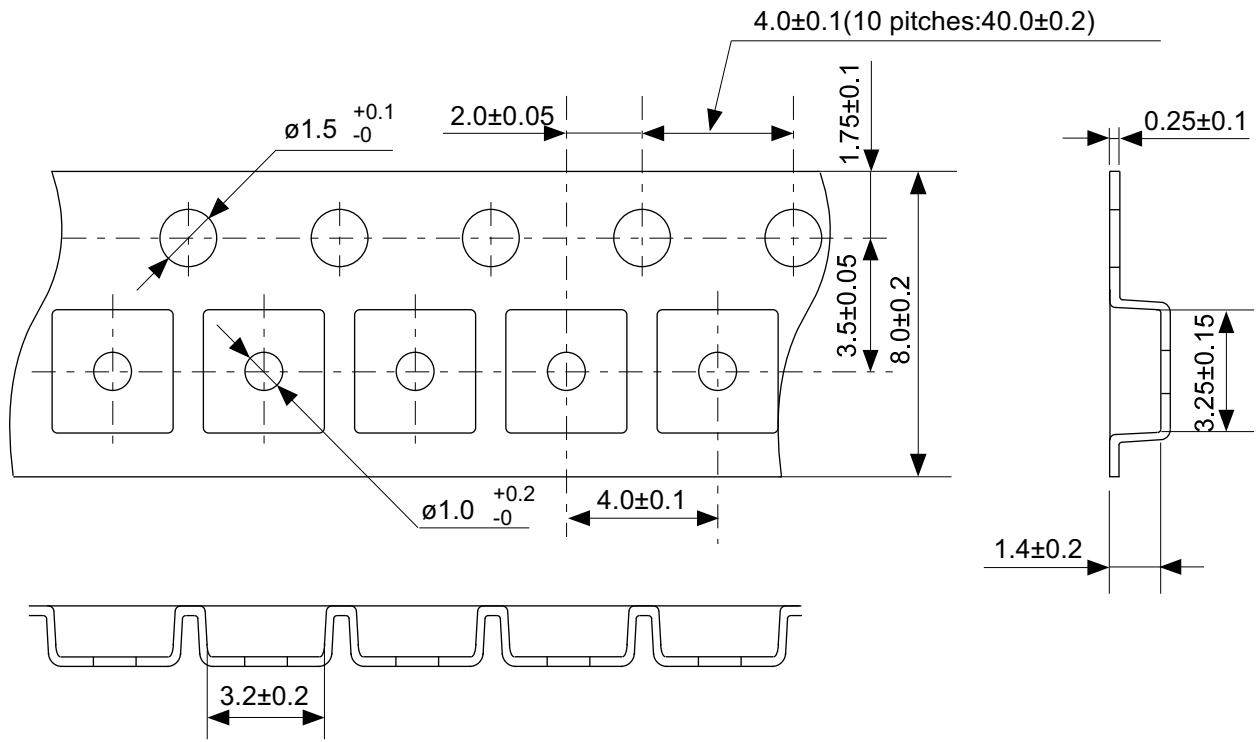

No. MP006-A-C-SD-3.1

TITLE	SOT236-A-Carrier Tape
No.	MP006-A-C-SD-3.1
SCALE	
UNIT	mm
Seiko Instruments Inc.	

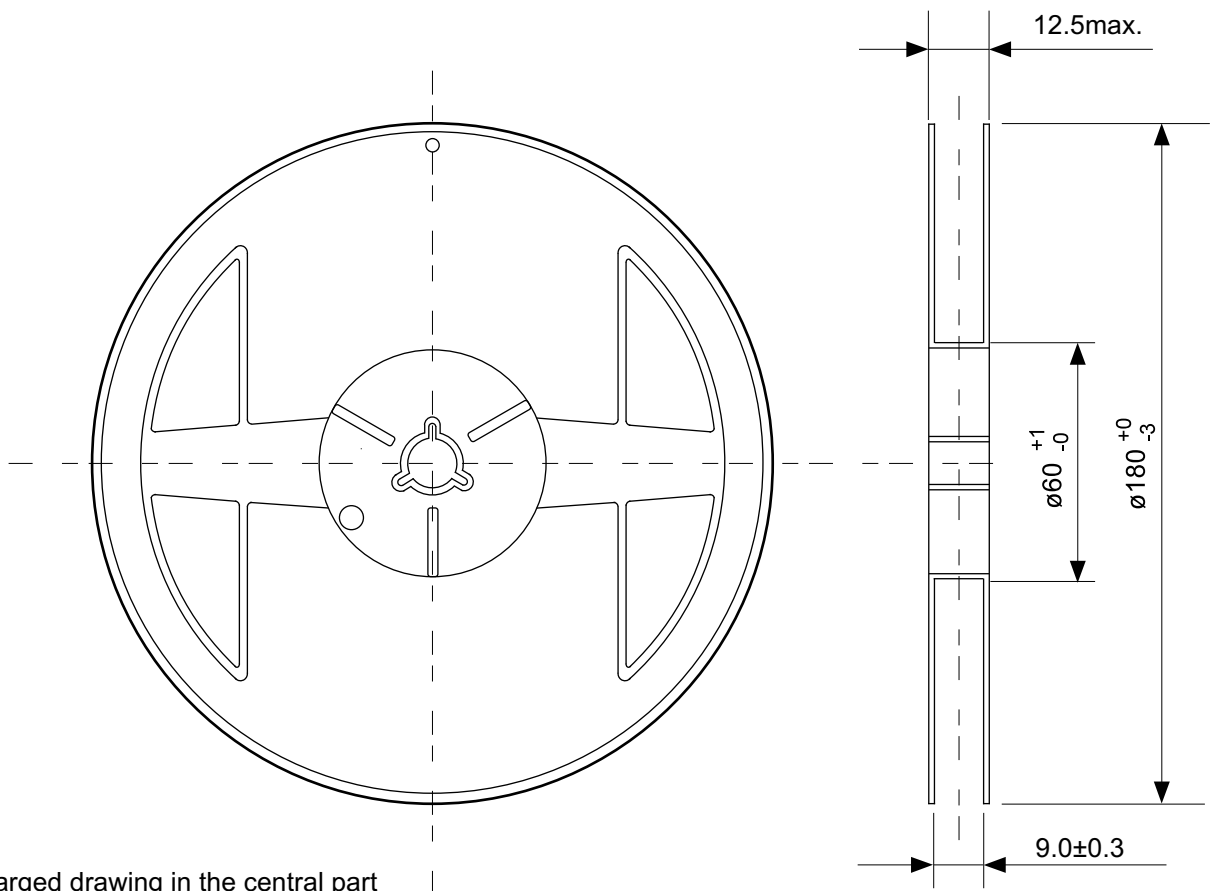

Enlarged drawing in the central part

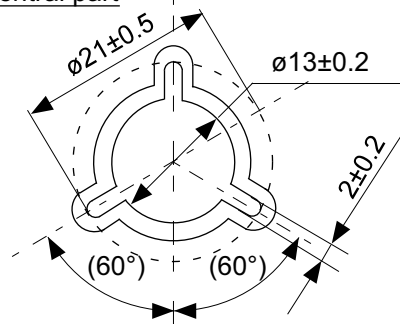

No. MP006-A-R-SD-2.1

TITLE	SOT236-A-Reel		
No.	MP006-A-R-SD-2.1		
SCALE		QTY	3,000
UNIT	mm		
Seiko Instruments Inc.			

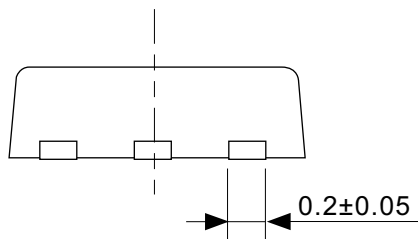
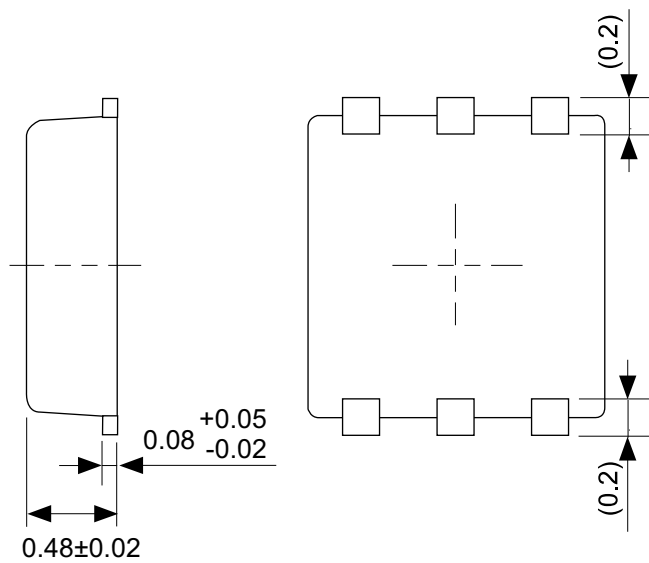
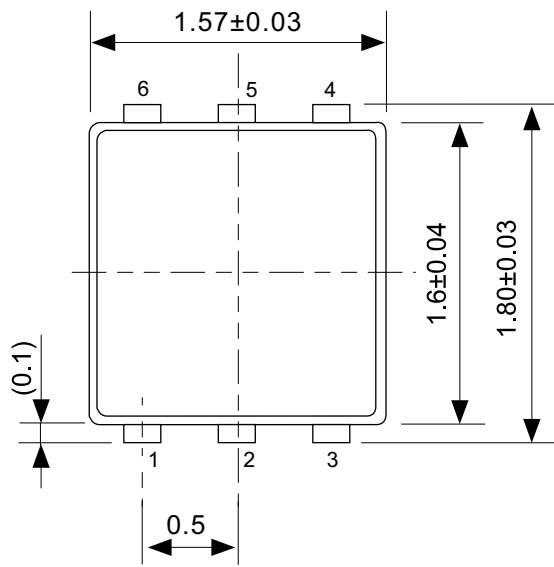

No. PG006-A-P-SD-2.0

TITLE	SNT-6A-A-PKG Dimensions
No.	PG006-A-P-SD-2.0
SCALE	
UNIT	mm
Seiko Instruments Inc.	

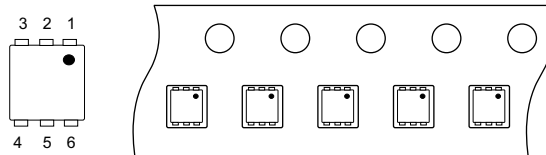
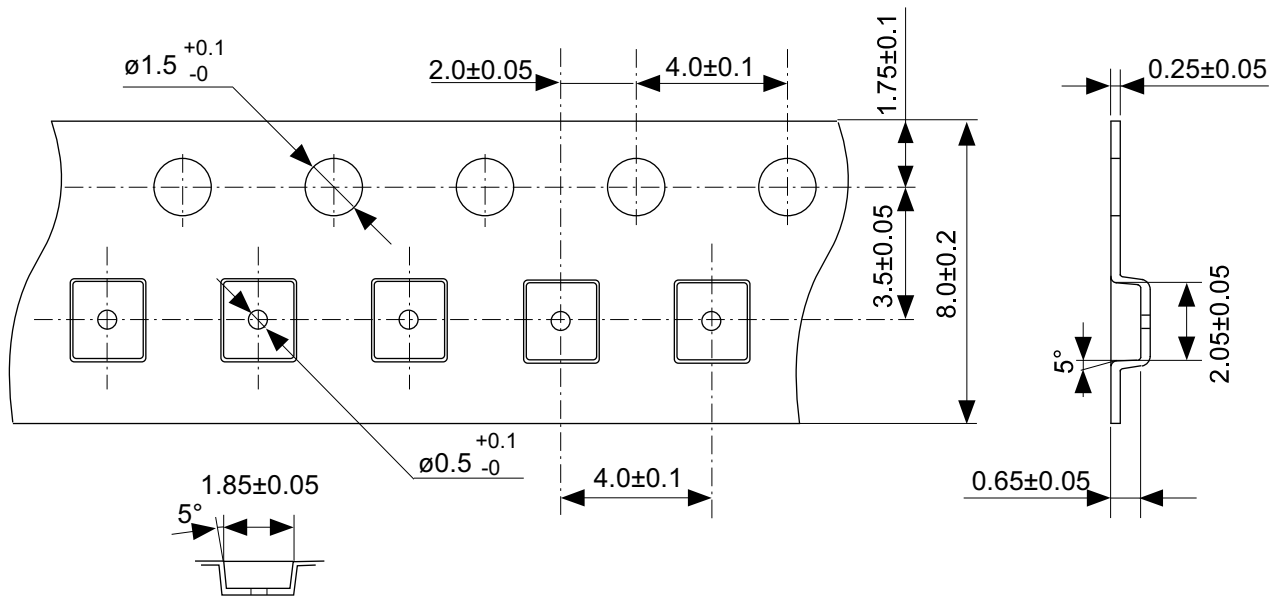

Feed direction →

No. PG006-A-C-SD-1.0

TITLE	SNT-6A-A-Carrier Tape
No.	PG006-A-C-SD-1.0
SCALE	
UNIT	mm
Seiko Instruments Inc.	

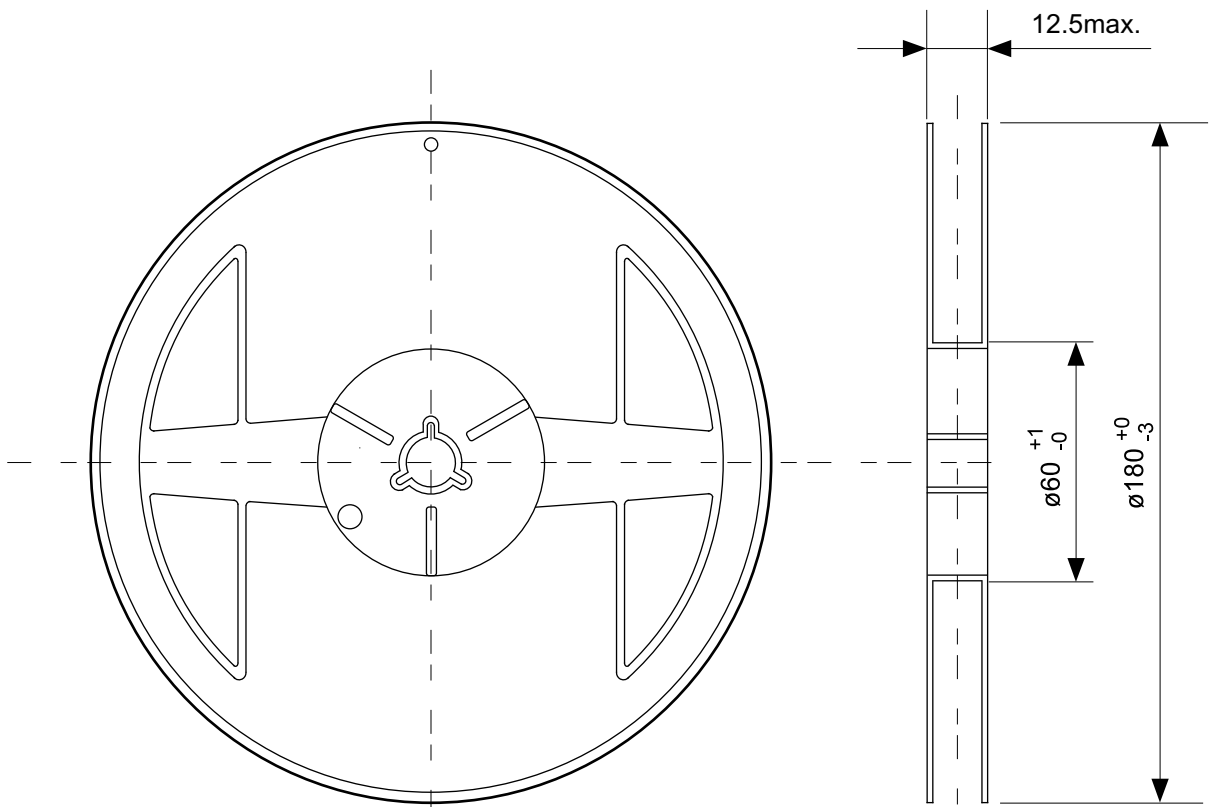

Enlarged drawing in the central part



No. PG006-A-R-SD-1.0

TITLE	SNT-6A-A-Reel		
No.	PG006-A-R-SD-1.0		
SCALE		QTY.	5,000
UNIT	mm		
Seiko Instruments Inc.			

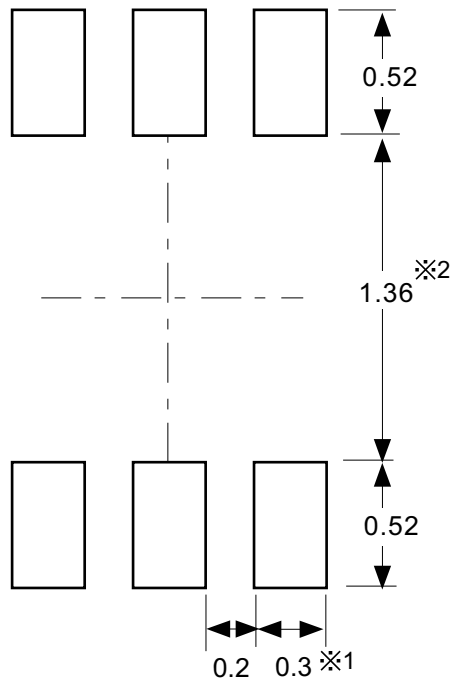

※1. ランドパターンの幅に注意してください (0.25 mm min. / 0.30 mm typ.).
 ※2. パッケージ中央にランドパターンを広げないでください (1.30 mm ~ 1.40 mm)。

- 注意**
1. パッケージのモールド樹脂下にシルク印刷やハンダ印刷などしないでください。
 2. パッケージ下の配線上のソルダーレジストなどの厚みをランドパターン表面から0.03 mm以下にしてください。
 3. マスク開口サイズと開口位置はランドパターンと合わせてください。
 4. 詳細は“SNTパッケージ活用の手引き”を参照してください。

※1. Pay attention to the land pattern width (0.25 mm min. / 0.30 mm typ.).
 ※2. Do not widen the land pattern to the center of the package (1.30 mm ~ 1.40 mm).

- Caution**
1. Do not do silkscreen printing and solder printing under the mold resin of the package.
 2. The thickness of the solder resist on the wire pattern under the package should be 0.03 mm or less from the land pattern surface.
 3. Match the mask aperture size and aperture position with the land pattern.
 4. Refer to "SNT Package User's Guide" for details.

※1. 请注意焊盘模式的宽度 (0.25 mm min. / 0.30 mm typ.).
 ※2. 请勿向封装中间扩展焊盘模式 (1.30 mm ~ 1.40 mm)。

- 注意**
1. 请勿在树脂型封装的下面印刷丝网、焊锡。
 2. 在封装下、布线上的阻焊膜厚度 (从焊盘模式表面起) 请控制在0.03 mm以下。
 3. 掩膜的开口尺寸和开口位置请与焊盘模式对齐。
 4. 详细内容请参阅 "SNT封装的应用指南"。

No. PG006-A-L-SD-4.0

TITLE	SNT-6A-A-Land Recommendation
No.	PG006-A-L-SD-4.0
SCALE	
UNIT	mm
Seiko Instruments Inc.	



Seiko Instruments Inc.
www.sii-ic.com

- The information described herein is subject to change without notice.
- Seiko Instruments Inc. is not responsible for any problems caused by circuits or diagrams described herein whose related industrial properties, patents, or other rights belong to third parties. The application circuit examples explain typical applications of the products, and do not guarantee the success of any specific mass-production design.
- When the products described herein are regulated products subject to the Wassenaar Arrangement or other agreements, they may not be exported without authorization from the appropriate governmental authority.
- Use of the information described herein for other purposes and/or reproduction or copying without the express permission of Seiko Instruments Inc. is strictly prohibited.
- The products described herein cannot be used as part of any device or equipment affecting the human body, such as exercise equipment, medical equipment, security systems, gas equipment, vehicle equipment, in-vehicle equipment, aviation equipment, aerospace equipment, and nuclear-related equipment, without prior written permission of Seiko Instruments Inc.
- The products described herein are not designed to be radiation-proof.
- Although Seiko Instruments Inc. exerts the greatest possible effort to ensure high quality and reliability, the failure or malfunction of semiconductor products may occur. The user of these products should therefore give thorough consideration to safety design, including redundancy, fire-prevention measures, and malfunction prevention, to prevent any accidents, fires, or community damage that may ensue.