



Model CV Series

Advanced PLL HCMOS, LVPECL or LVDS VCXO

Features

- Ceramic Surface Mount Package
- Very Low Phase Jitter Performance, 150fs Typical
- Quartz Crystal Based Design
- Frequency Range to 2.1GHz *
- +1.8V, +2.5V or +3.3V Operation
- Output Enable Standard
- Tape and Reel Packaging, EIA-481

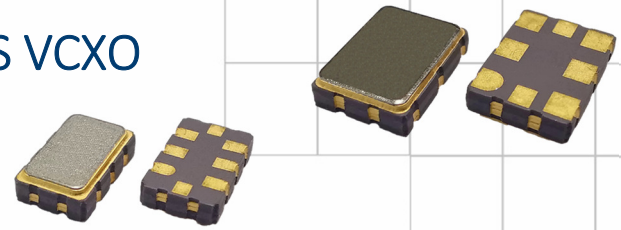

Part Dimensions:
 5.0 × 3.2 × 1.5mm • 61.8mg
 7.0 × 5.0 × 1.9mm • 172.74mg

Standard Frequencies

* See Page 12 for common frequencies.
 Check with factory for availability of frequencies not listed.

Applications

- SerDes
- Storage Area Networking
- Broadband Access
- SONET/SDH/DWDM
- PON
- Ethernet/Gbe/SyncE
- Fiber Channel
- Medical Electronics
- Test and Measurement

Description

CTS Model CV Series is a low cost, high performance clock oscillator supporting HCMOS and differential LVPECL or LVDS outputs. Employing the latest IC technology, CV Series has excellent stability and low jitter/phase noise performance.

Ordering Information

Model	Package Size	Output Type	Frequency Code	Frequency Stability	Temperature Range	Supply Voltage	Pullability Minimum	Packaging																							
CV	50	C	XXX or XXXX	3	I	L	6	T																							
	<table border="1"> <thead> <tr> <th>Code</th> <th>Dimensions</th> </tr> </thead> <tbody> <tr> <td>50</td> <td>5.0mmx3.2mm</td> </tr> <tr> <td>70</td> <td>7.0mmx5.0mm</td> </tr> </tbody> </table>	Code	Dimensions	50	5.0mmx3.2mm	70	7.0mmx5.0mm		<table border="1"> <thead> <tr> <th>Code</th> <th>Frequency</th> </tr> </thead> <tbody> <tr> <td colspan="2">Product Frequency Code ¹</td> </tr> </tbody> </table>	Code	Frequency	Product Frequency Code ¹			<table border="1"> <thead> <tr> <th>Code</th> <th>Temp. Range</th> </tr> </thead> <tbody> <tr> <td>C</td> <td>-20°C to +70°C</td> </tr> <tr> <td>I</td> <td>-40°C to +85°C</td> </tr> </tbody> </table>	Code	Temp. Range	C	-20°C to +70°C	I	-40°C to +85°C		<table border="1"> <thead> <tr> <th>Code</th> <th>Voltage</th> </tr> </thead> <tbody> <tr> <td>6</td> <td>±100ppm</td> </tr> <tr> <td>7</td> <td>±150ppm</td> </tr> </tbody> </table>	Code	Voltage	6	±100ppm	7	±150ppm		
Code	Dimensions																														
50	5.0mmx3.2mm																														
70	7.0mmx5.0mm																														
Code	Frequency																														
Product Frequency Code ¹																															
Code	Temp. Range																														
C	-20°C to +70°C																														
I	-40°C to +85°C																														
Code	Voltage																														
6	±100ppm																														
7	±150ppm																														
		<table border="1"> <thead> <tr> <th>Code</th> <th>Output</th> </tr> </thead> <tbody> <tr> <td>C</td> <td>HCMOS</td> </tr> <tr> <td>P</td> <td>LVPECL</td> </tr> <tr> <td>L</td> <td>LVDS</td> </tr> </tbody> </table>	Code	Output	C	HCMOS	P	LVPECL	L	LVDS	<table border="1"> <thead> <tr> <th>Code</th> <th>Stability</th> </tr> </thead> <tbody> <tr> <td>5</td> <td>±25ppm</td> </tr> <tr> <td>3</td> <td>±50ppm</td> </tr> </tbody> </table>	Code	Stability	5	±25ppm	3	±50ppm	<table border="1"> <thead> <tr> <th>Code</th> <th>Voltage</th> </tr> </thead> <tbody> <tr> <td>M</td> <td>+1.8Vdc ²</td> </tr> <tr> <td>N</td> <td>+2.5Vdc</td> </tr> <tr> <td>L</td> <td>+3.3Vdc</td> </tr> </tbody> </table>	Code	Voltage	M	+1.8Vdc ²	N	+2.5Vdc	L	+3.3Vdc	<table border="1"> <thead> <tr> <th>Code</th> <th>Packing</th> </tr> </thead> <tbody> <tr> <td>T</td> <td>1k pcs./reel</td> </tr> </tbody> </table>	Code	Packing	T	1k pcs./reel
Code	Output																														
C	HCMOS																														
P	LVPECL																														
L	LVDS																														
Code	Stability																														
5	±25ppm																														
3	±50ppm																														
Code	Voltage																														
M	+1.8Vdc ²																														
N	+2.5Vdc																														
L	+3.3Vdc																														
Code	Packing																														
T	1k pcs./reel																														

Notes:

- 1] Refer to document 016-1454-0, Frequency Code Tables. [3-digits for frequencies <100MHz, 4-digits for frequencies 100MHz or greater.]
- 2] HCMOS and LVDS outputs only.

**Not all performance combinations and frequencies may be available.
 Contact your local CTS Representative or CTS Customer Service for availability.**

This product is specified for use only in standard commercial applications. Supplier disclaims all express and implied warranties and liability in connection with any use of this product in any non-commercial applications or in any application that may expose the product to conditions that are outside of the tolerances provided in its specification.



Electrical Specifications

Operating Conditions

PARAMETER	SYMBOL	CONDITIONS	MIN	TYP	MAX	UNIT
Maximum Supply Voltage	V_{CC}	-	-0.5	-	3.8	V
Maximum Control Voltage	V_C	$V_{CC} = \text{nominal}$	-0.5	-	3.8	V
Supply Voltage	V_{CC}	$\pm 5\%$, HCMOS & LVDS only	1.71	1.8	1.89	
		$\pm 10\%$	2.25	2.5	2.75	V
			2.97	3.3	3.63	
Supply Current						
HCMOS	I_{CC}	Maximum Load	-	80	-	
LVPECL		Maximum Current Value @ +3.3V	-	100	120	mA
LVDS			-	75	90	
Operating Temperature	T_A	-	-20	+25	+70	$^{\circ}\text{C}$
			-40		+85	
Storage Temperature	T_{STG}	-	-55	-	+125	$^{\circ}\text{C}$

Frequency Stability

PARAMETER	SYMBOL	CONDITIONS	MIN	TYP	MAX	UNIT
Frequency Range	f_0	-		15 - 250		MHz
				15 - 2,100		
Frequency Stability [Note 1]	$\Delta f/f_0$	-		25 or 50		$\pm\text{ppm}$
Aging	$\Delta f/f_{25}$	First Year @ +25 $^{\circ}\text{C}$, nominal V_{CC}	-3	-	3	ppm

1.] Inclusive of initial tolerance at time of shipment, changes in supply voltage, load, temperature and 1st year aging.

Output Parameters

PARAMETER	SYMBOL	CONDITIONS	MIN	TYP	MAX	UNIT
Output Type	-	-		HCMOS		-
Output Load	C_L	-	-	-	15	pF
Output Voltage Levels	V_{OH}	CMOS Load	$V_{CC} - 0.4V$	-	-	
	V_{OL}	CMOS Load	-	-	$0.1V_{CC}$	V
		CMOS Load @ +1.8V	-	-	0.3	
Output Duty Cycle	SYM	@ 50% Level, +2.5V and +3.3V	45	-	55	%
		@ 50% Level, +1.8V	40	-	60	
Rise and Fall Time	T_R, T_F	@ 10%/90% Levels, $C_L = 15\text{pF}$	-	-	5	ns
LVPECL						
Output Type	-	-		LVPECL		-
Output Load	R_L	Terminated to $V_{CC} - 2.0V$	-	50	-	Ohms
Output Voltage Levels	V_{OH}	PECL Load	$V_{CC} - 1.165$	-	$V_{CC} - 0.80$	V
	V_{OL}		$V_{CC} - 2.0$	-	$V_{CC} - 1.55$	
Output Duty Cycle	SYM	@ $V_{CC} - 1.3V$	45	-	55	%
Differential Output Voltage	V_{OD}	$R_L = 50\text{ Ohms}$	595	-	930	mV
Rise and Fall Time	T_R, T_F	@ 20%/80% Levels, $R_L = 50\text{ Ohms}$	-	-	0.40	ns



Electrical Specifications

Output Parameters

PARAMETER	SYMBOL	CONDITIONS	MIN	TYP	MAX	UNIT
Output Type	-	-		LVDS		-
Output Load	R_L	Between Outputs	-	100	-	Ohms
Output Voltage Levels	V_{OH}	LVDS Load	-	1.40	1.60	V
	V_{OL}		0.90	1.10	-	
Output Duty Cycle	SYM	@ 1.25V	45	-	55	%
Differential Output Voltage	V_{OD}	$R_L = 100$ Ohms	250	-	450	mV
Offset Voltage	V_{OS}	LVDS Load	1.20	1.25	1.30	V
Rise and Fall Time	T_R, T_F	@ 20%/80% Levels, $R_L = 100$ Ohms	-	-	0.40	ns

PARAMETER	SYMBOL	CONDITIONS	MIN	TYP	MAX	UNIT
Start Up Time	T_S	Application of V_{CC}	-	5	10	ms
Enable Function [Tri-State]						
Enable Input Voltage	V_{IH}	Pin 2 Logic '1', Output Enabled	$0.8V_{CC}$	-	-	V
Disable Input Voltage	V_{IL}	Pin 2 Logic '0', Output Disabled	-	-	$0.2V_{CC}$	V
		Pin 2 Logic '0', Output Disabled, HCMOS	-	63	-	
Disable Current	I_{IL}	Pin 2 Logic '0', Output Disabled, LVPECL	-	99	-	mA
		Pin 2 Logic '0', Output Disabled, LVDS	-	74	-	
Disable Time	T_{PLZ}	Pin 2 Logic '0', Output Disabled	-	-	10	μ s
Enable Time	T_{PLZ}	Pin 2 Logic '1', Output Enabled	-	-	2.5	ms
Phase Jitter, RMS	t_{jrms}	Bandwidth 12 kHz - 20 MHz	-	150	300	fs

Control Voltage

PARAMETER	SYMBOL	CONDITIONS	MIN	TYP	MAX	UNIT
Control Voltage	V_C	$V_{CC} = +1.8V$, LVDS only	0.0	0.90	1.8	V
		$V_{CC} = +2.5V$	0.25	1.25	2.25	
		$V_{CC} = +3.3V$	0.3	1.65	3.0	
Frequency Pulling Range	$\Delta f/f_0$	V_C range	± 100 or ± 150 minimum			ppm
Linearity	L	Best Straight Line Fit	-	-	± 10	%
Gain Transfer	K_V	Pull Sensitivity; @ +1.25V, +25°C	-	80	260	ppm/V
		Pull Sensitivity; @ +1.65V, +25°C				
Input Impedance	Z_{Vc}	-	5	-	-	MOhms
Modulation Roll-off	-	@ -3dB	10	-	-	kHz
Transfer Function	-	-		Positive		-

Enable Truth Table

HCMOS

Pin 2	Pin 4
Logic '1'	Output Enabled
Open	Output Enabled
Logic '0'	Output Disabled, High Impedance

Enable Truth Table

LVPECL or LVDS

Pin 2	Pin 4 & Pin 5
Logic '1'	Output Enabled
Open	Output Enabled
Logic '0'	Output Disabled, High Impedance

Electrical Specifications

Output Waveform

HCMOS

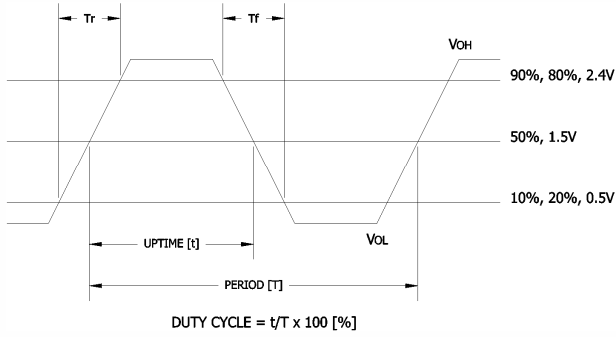

Output Waveform

LVPECL or LVDS

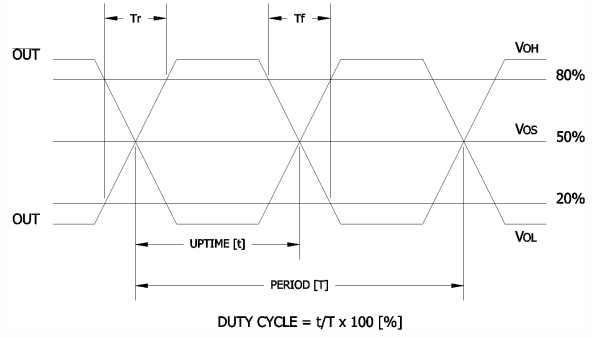

Test Circuits

HCMOS

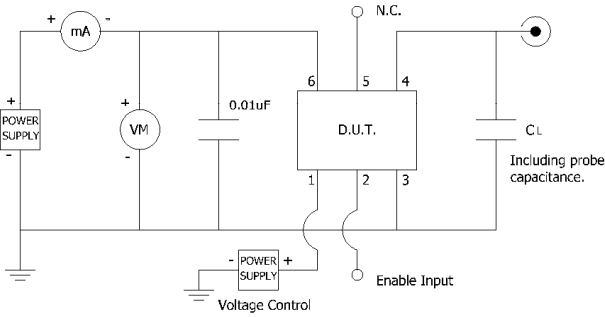

LVPECL

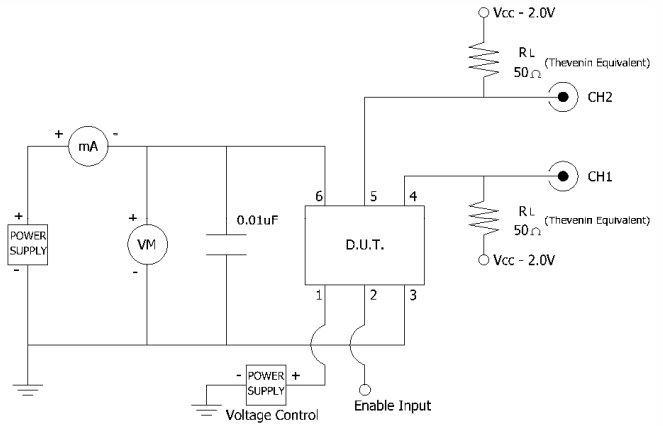

LVDS

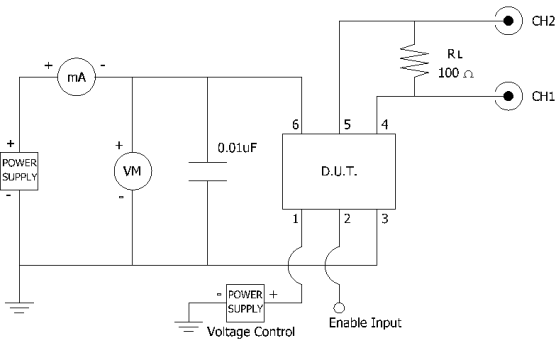

LVDS @ +1.8V

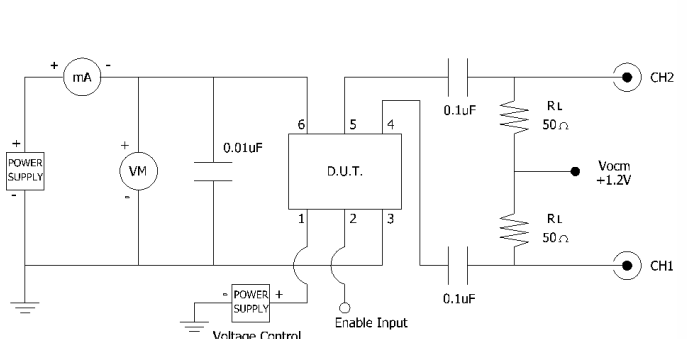



Electrical Specifications

Performance Data

Phase Noise [typical]

100MHz, $V_{CC} = +3.3V$, $T_A = +25^\circ C$

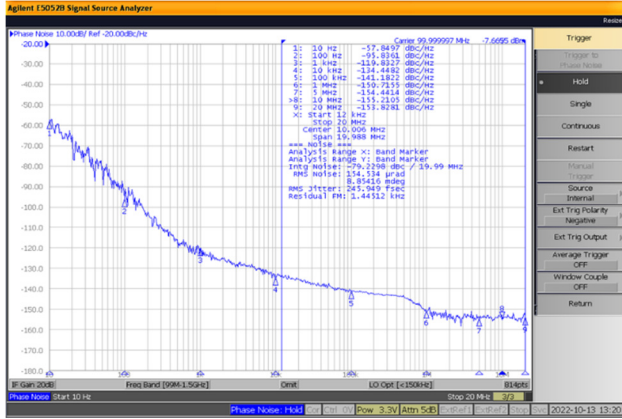

106.25MHz, $V_{CC} = +3.3V$, $T_A = +25^\circ C$

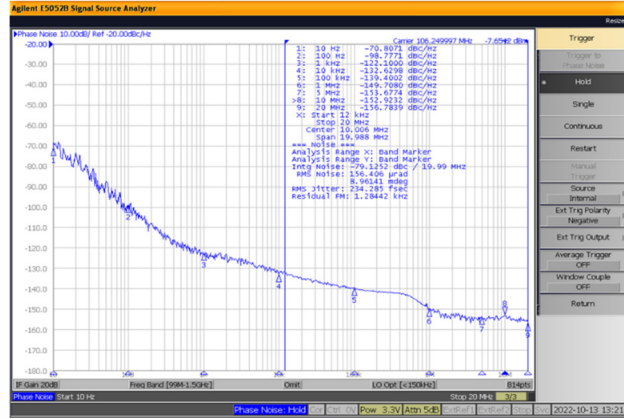

122.88MHz, $V_{CC} = +3.3V$, $T_A = +25^\circ C$

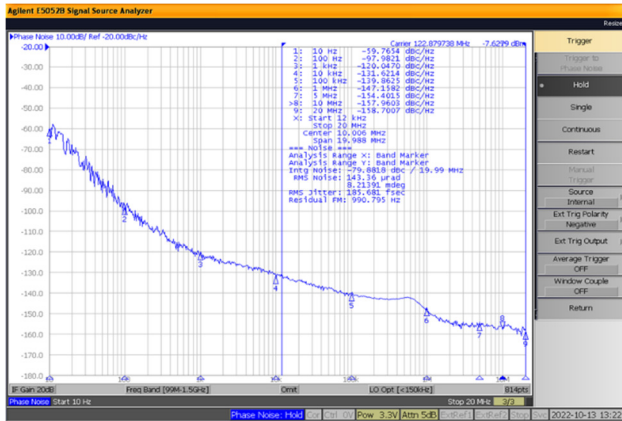

125MHz, $V_{CC} = +3.3V$, $T_A = +25^\circ C$

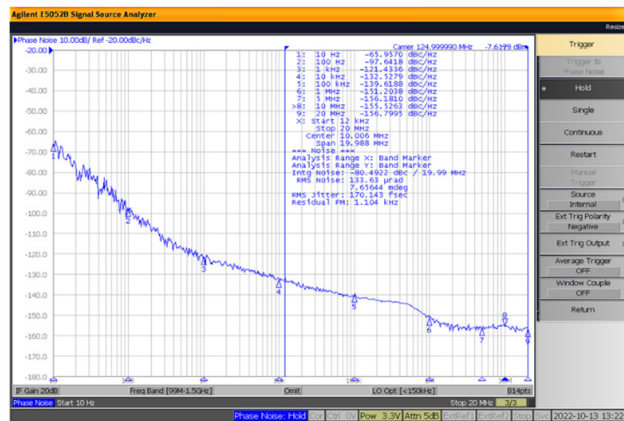

150MHz, $V_{CC} = +3.3V$, $T_A = +25^\circ C$

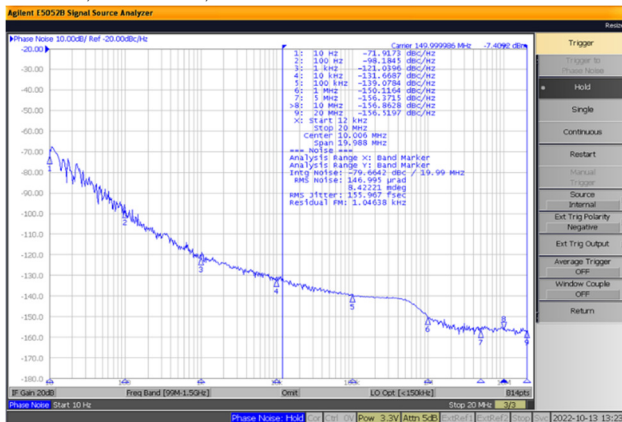

156.25MHz, $V_{CC} = +3.3V$, $T_A = +25^\circ C$

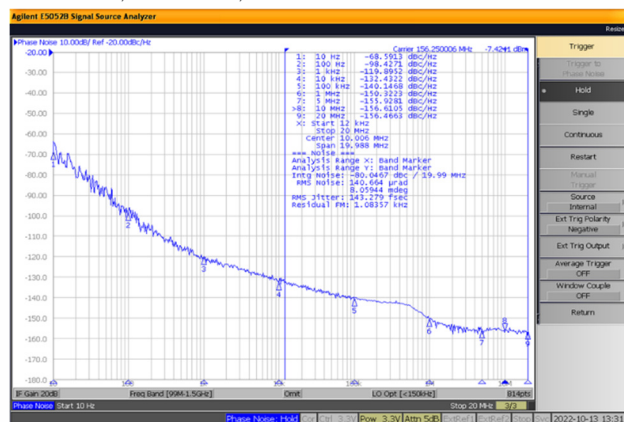



Electrical Specifications

Performance Data

Phase Noise [typical]

200MHz, $V_{CC} = +3.3V$, $T_A = +25^\circ C$

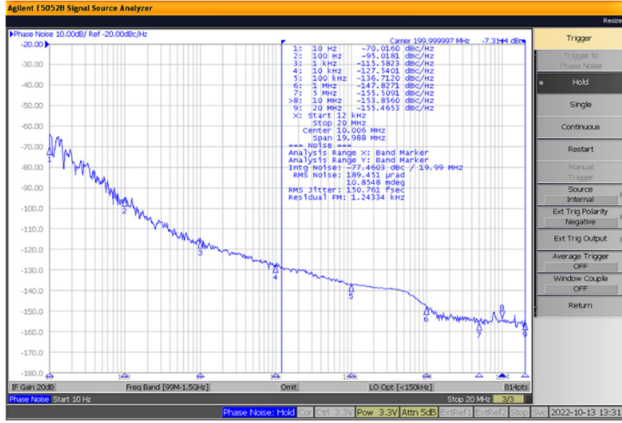

212.5MHz, $V_{CC} = +3.3V$, $T_A = +25^\circ C$

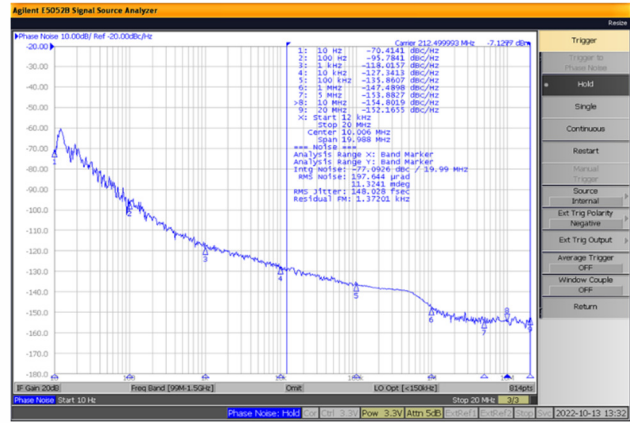

250MHz, $V_{CC} = +3.3V$, $T_A = +25^\circ C$

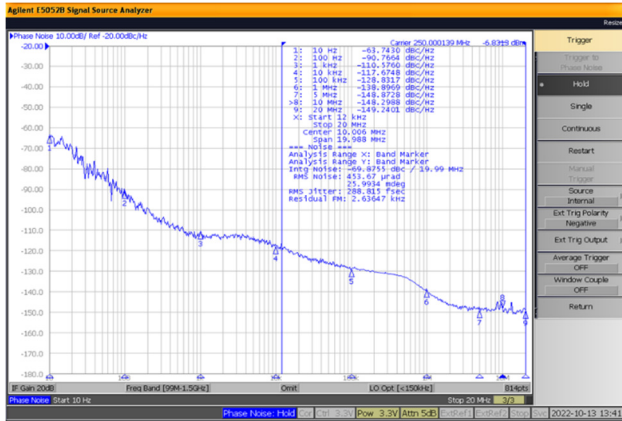

312.5MHz, $V_{CC} = +3.3V$, $T_A = +25^\circ C$

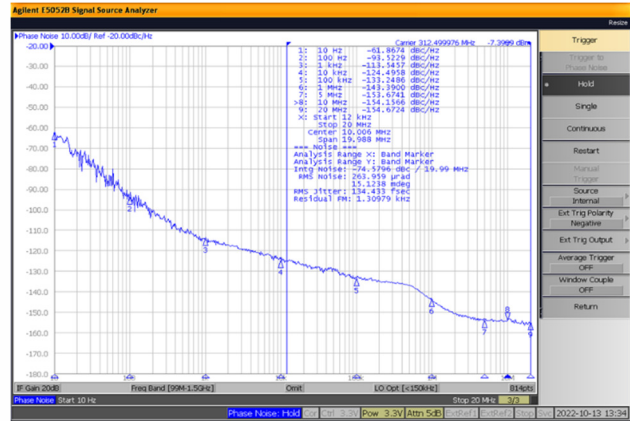

622.08MHz, $V_{CC} = +3.3V$, $T_A = +25^\circ C$

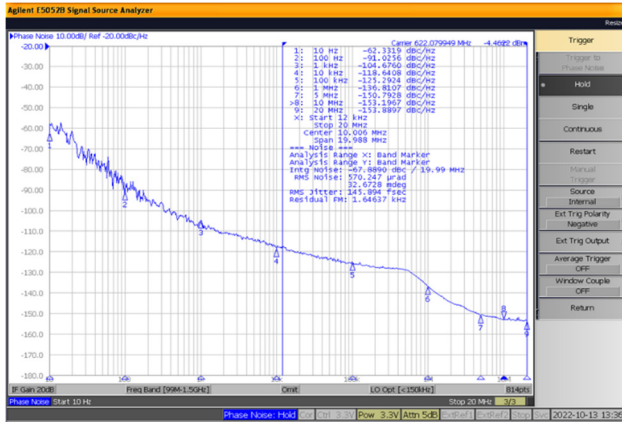

644.53125MHz, $V_{CC} = +3.3V$, $T_A = +25^\circ C$

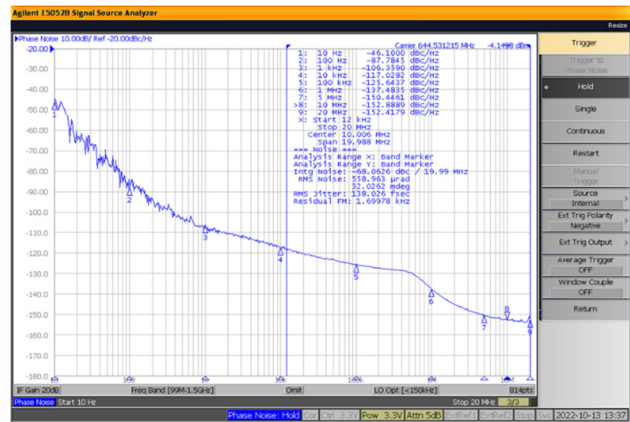



Electrical Specifications

Performance Data

Phase Noise Tabulated

Typical, $V_{CC} = +3.3V$, $T_A = +25^\circ C$

PARAMETER	SYMBOL	CONDITIONS	TYP	UNIT	
100.0000MHz					
Phase Noise		Single Side Band			
		@ 10Hz	-57.8497		
		@ 100Hz	-95.8361		
		@ 1kHz	-119.8327		
		@ 10kHz	-134.4482	dBc/Hz	
		@ 100kHz	-141.1822		
		@ 1MHz	-150.7155		
		@ 5MHz	-154.4414		
		@ 10MHz	-155.2105		
		@ 20MHz	-153.8281		
Phase Jitter, RMS	tjrms	Integration Bandwidth 12kHz - 20MHz	245.9490		fs

PARAMETER	SYMBOL	CONDITIONS	TYP	UNIT	
122.8800MHz					
Phase Noise		Single Side Band			
		@ 10Hz	-59.7654		
		@ 100Hz	-97.9821		
		@ 1kHz	-120.0470		
		@ 10kHz	-131.6214	dBc/Hz	
		@ 100kHz	-139.8625		
		@ 1MHz	-147.1582		
		@ 5MHz	-154.4015		
		@ 10MHz	-157.9603		
		@ 20MHz	-158.7007		
Phase Jitter, RMS	tjrms	Integration Bandwidth 12kHz - 20MHz	185.6810		fs

PARAMETER	SYMBOL	CONDITIONS	TYP	UNIT	
150.0000MHz					
Phase Noise		Single Side Band			
		@ 10Hz	-71.9173		
		@ 100Hz	-98.1845		
		@ 1kHz	-121.0396		
		@ 10kHz	-131.6687	dBc/Hz	
		@ 100kHz	-139.0784		
		@ 1MHz	-150.1164		
		@ 5MHz	-156.3715		
		@ 10MHz	-156.8628		
		@ 20MHz	-156.5197		
Phase Jitter, RMS	tjrms	Integration Bandwidth 12kHz - 20MHz	155.9670		fs

Typical, $V_{CC} = +3.3V$, $T_A = +25^\circ C$

PARAMETER	SYMBOL	CONDITIONS	TYP	UNIT	
106.2500MHz					
Phase Noise		Single Side Band			
		@ 10Hz	-70.8071		
		@ 100Hz	-98.7771		
		@ 1kHz	-122.1000		
		@ 10kHz	-132.6298	dBc/Hz	
		@ 100kHz	-139.4002		
		@ 1MHz	-149.7080		
		@ 5MHz	-153.6774		
		@ 10MHz	-152.9232		
		@ 20MHz	-156.7839		
Phase Jitter, RMS	tjrms	Integration Bandwidth 12kHz - 20MHz	234.2850		fs

PARAMETER	SYMBOL	CONDITIONS	TYP	UNIT	
125.0000MHz					
Phase Noise		Single Side Band			
		@ 10Hz	-65.9570		
		@ 100Hz	-97.6418		
		@ 1kHz	-121.4336		
		@ 10kHz	-132.5279	dBc/Hz	
		@ 100kHz	-139.6188		
		@ 1MHz	-151.2038		
		@ 5MHz	-156.1810		
		@ 10MHz	-155.5263		
		@ 20MHz	-156.7995		
Phase Jitter, RMS	tjrms	Integration Bandwidth 12kHz - 20MHz	170.1430		fs

PARAMETER	SYMBOL	CONDITIONS	TYP	UNIT	
156.2500MHz					
Phase Noise		Single Side Band			
		@ 10Hz	-68.5913		
		@ 100Hz	-98.4271		
		@ 1kHz	-119.8952		
		@ 10kHz	-132.4322	dBc/Hz	
		@ 100kHz	-140.1468		
		@ 1MHz	-150.3223		
		@ 5MHz	-155.9281		
		@ 10MHz	-156.6105		
		@ 20MHz	-156.4663		
Phase Jitter, RMS	tjrms	Integration Bandwidth 12kHz - 20MHz	143.2790		fs



Electrical Specifications

Performance Data

Phase Noise Tabulated

Typical, $V_{CC} = +3.3V$, $T_A = +25^\circ C$

PARAMETER	SYMBOL	CONDITIONS	TYP	UNIT	
200.0000MHz					
Phase Noise		Single Side Band			
		@ 10Hz	-70.0160		
		@ 100Hz	-95.0181		
		@ 1kHz	-115.5823		
		@ 10kHz	-127.5401	dBc/Hz	
		@ 100kHz	-136.7120		
		@ 1MHz	-147.8271		
		@ 5MHz	-155.5091		
		@ 10MHz	-153.8560		
		@ 20MHz	-155.4653		
Phase Jitter, RMS	tjrms	Integration Bandwidth 12kHz - 20MHz	150.7610		fs

PARAMETER	SYMBOL	CONDITIONS	TYP	UNIT	
250.0000MHz					
Phase Noise		Single Side Band			
		@ 10Hz	-63.7430		
		@ 100Hz	-90.7664		
		@ 1kHz	-110.5760		
		@ 10kHz	-117.6748	dBc/Hz	
		@ 100kHz	-128.8317		
		@ 1MHz	-138.8969		
		@ 5MHz	-148.8728		
		@ 10MHz	-148.2933		
		@ 20MHz	-149.2401		
Phase Jitter, RMS	tjrms	Integration Bandwidth 12kHz - 20MHz	288.8150		fs

PARAMETER	SYMBOL	CONDITIONS	TYP	UNIT	
622.0800MHz					
Phase Noise		Single Side Band			
		@ 10Hz	-62.3319		
		@ 100Hz	-91.0256		
		@ 1kHz	-104.6760		
		@ 10kHz	-118.6408	dBc/Hz	
		@ 100kHz	-125.2924		
		@ 1MHz	-136.8107		
		@ 5MHz	-150.7928		
		@ 10MHz	-153.1967		
		@ 20MHz	-153.8897		
Phase Jitter, RMS	tjrms	Integration Bandwidth 12kHz - 20MHz	145.8940		fs

Typical, $V_{CC} = +3.3V$, $T_A = +25^\circ C$

PARAMETER	SYMBOL	CONDITIONS	TYP	UNIT	
212.5000MHz					
Phase Noise		Single Side Band			
		@ 10Hz	-70.4141		
		@ 100Hz	-95.7841		
		@ 1kHz	-118.0157		
		@ 10kHz	-127.3413	dBc/Hz	
		@ 100kHz	-135.8607		
		@ 1MHz	-147.4898		
		@ 5MHz	-153.8827		
		@ 10MHz	-154.8019		
		@ 20MHz	-152.1655		
Phase Jitter, RMS	tjrms	Integration Bandwidth 12kHz - 20MHz	148.0280		fs

PARAMETER	SYMBOL	CONDITIONS	TYP	UNIT	
312.5000MHz					
Phase Noise		Single Side Band			
		@ 10Hz	-61.8674		
		@ 100Hz	-93.5229		
		@ 1kHz	-113.5457		
		@ 10kHz	-124.4958	dBc/Hz	
		@ 100kHz	-133.2486		
		@ 1MHz	-143.3900		
		@ 5MHz	-153.6741		
		@ 10MHz	-154.1566		
		@ 20MHz	-154.6724		
Phase Jitter, RMS	tjrms	Integration Bandwidth 12kHz - 20MHz	134.4330		fs

PARAMETER	SYMBOL	CONDITIONS	TYP	UNIT	
644.53125MHz					
Phase Noise		Single Side Band			
		@ 10Hz	-46.1000		
		@ 100Hz	-87.7845		
		@ 1kHz	-106.3590		
		@ 10kHz	-117.0282	dBc/Hz	
		@ 100kHz	-125.6437		
		@ 1MHz	-137.4835		
		@ 5MHz	-150.4461		
		@ 10MHz	-152.8889		
		@ 20MHz	-152.4179		
Phase Jitter, RMS	tjrms	Integration Bandwidth 12kHz - 20MHz	138.0260		fs

Mechanical Specifications

Package Drawing

CV50

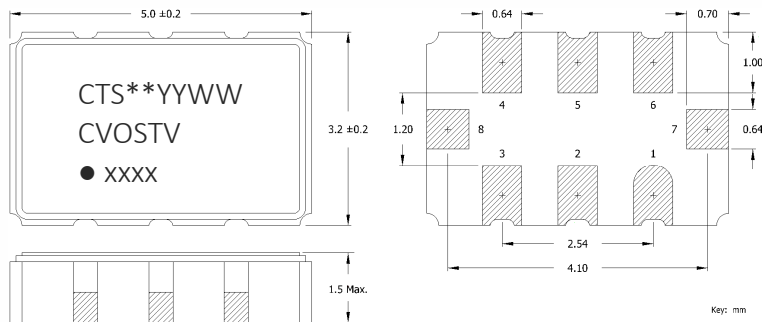

CV70

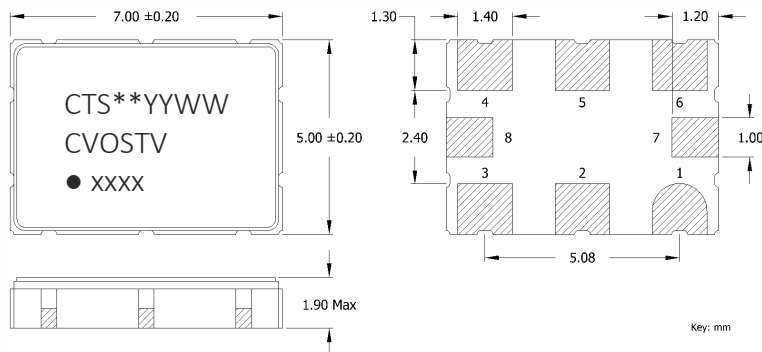

Marking Information

CV50 and CV70

- ** - Manufacturing Site Code.
- YYWW – Date Code; YY – year, WW – week.
- CV – Model series.
- O – Output Type; C = HCMOS, P = LVPECL, L = LVDS. [Refer to Ordering Information]
- ST – Frequency Stability/Temperature Code. [Refer to Ordering Information]
- V – Voltage Code; M = 1.8V, N = 2.5V, L = 3.3V.
- xxxx – Frequency Code.
3-digits, frequencies below 100MHz
4-digits, frequencies 100MHz or greater
[See document 016-1454-0, Frequency Code Tables.]

Notes

- JEDEC termination code (e4). Barrier-plating is nickel [Ni] with gold [Au] flash plate.
- Reflow conditions per JEDEC J-STD-020; +260°C maximum, 20 seconds.
- MSL = 1.

Mechanical Specifications

Recommended Pad Layout

CV50

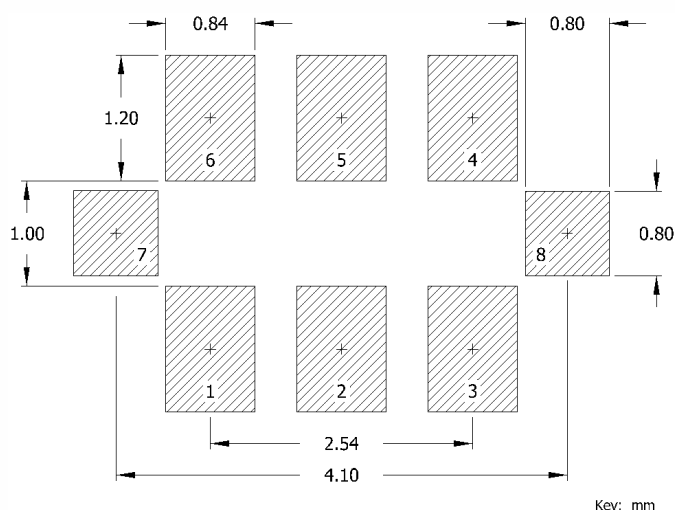

CV70

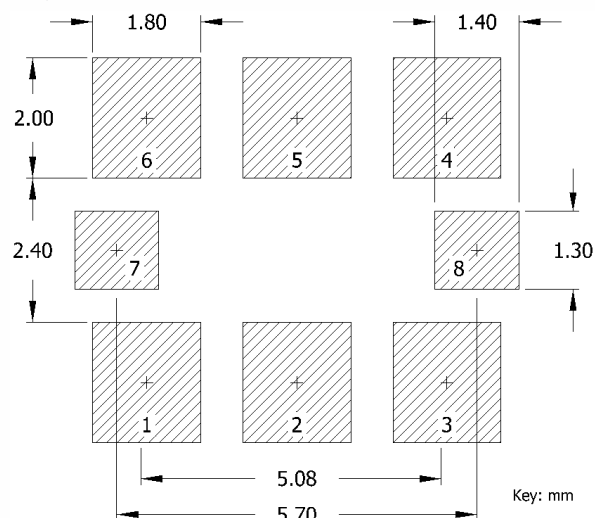

Pin Assignments

HCMOS

Pin	Symbol	Function
1	V _c	Voltage Control
2	EOH	Enable
3	GND	Circuit & Package Ground
4	Output	RF Output
5	N.C.	No Connect
6	V _{CC}	Supply Voltage
7	N.C.	Do Not Connect
8	N.C.	Do Not Connect

Pin Assignments

LVPECL or LVDS

Pin	Symbol	Function
1	V _c	Voltage Control
2	EOH	Enable
3	GND	Circuit & Package Ground
4	Output	RF Output
5	Output	Complimentary RF Output
6	V _{CC}	Supply Voltage
7	N.C.	Do Not Connect
8	N.C.	Do Not Connect

Table I - Date Code, Beginning year 2021

					MONTH											
					JAN	FEB	MAR	APR	MAY	JUN	JUL	AUG	SEP	OCT	NOV	DEC
YEAR																
2021	2025	2029	2033	2037	A	B	C	D	E	F	G	H	J	K	L	M
2022	2026	2030	2034	2038	N	P	Q	R	S	T	U	V	W	X	Y	Z
2023	2027	2031	2035	2039	a	b	c	d	e	f	g	h	j	k	l	m
2024	2028	2032	2036	2040	n	p	q	r	s	t	u	v	w	x	y	z

Packaging - Tape and Reel

Tape Drawing

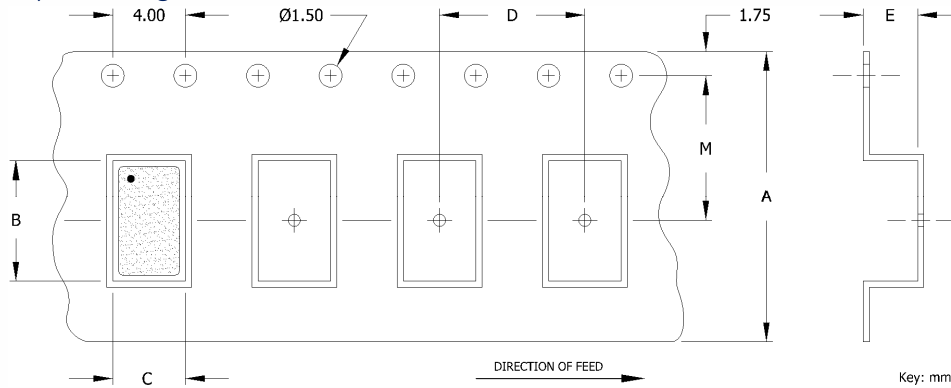

Reel Drawing

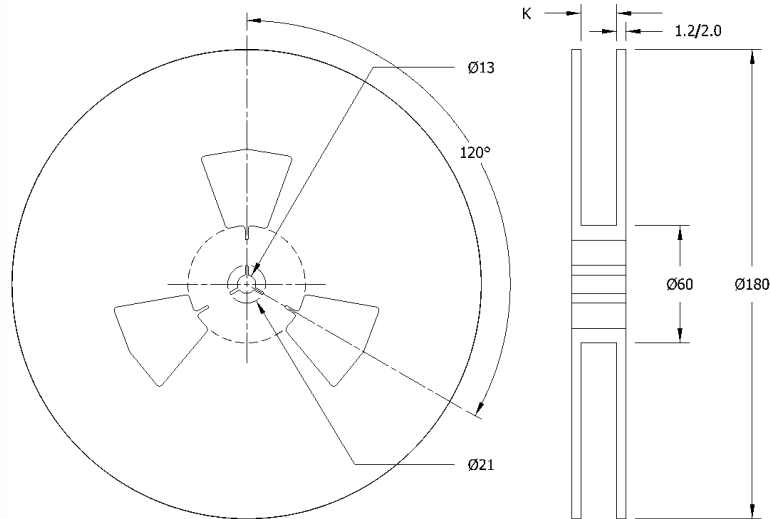

Tape Dimensions

PACKAGE	A	B	C	D	E	M	QUANTITY
CC50	12.00	5.30	3.60	8.00	1.40	5.50	1000
CC70	16.00	7.30	5.30	8.00	1.90	7.50	1000

Reel Dimensions

K
13.00
17.20

Notes

1. Complete CTS part number, frequency value and date code information must appear on reel and carton labels.



Addendum

Common Frequencies Available – MHz

FREQUENCY	FREQUENCY CODE	FREQUENCY	FREQUENCY CODE	FREQUENCY	FREQUENCY CODE	FREQUENCY	FREQUENCY CODE
100.000000	1000	155.520000	1555	250.000000	2500		
106.250000	1062	156.250000	1562	312.500000	3125		
122.880000	1228	160.000000	1600	622.080000	6220		
125.000000	1250	200.000000	2000	644.531250	6445		
150.000000	1500	212.500000	2125				