

Amphenol®

953 Series ST II® Compatible Connectors & Adapters

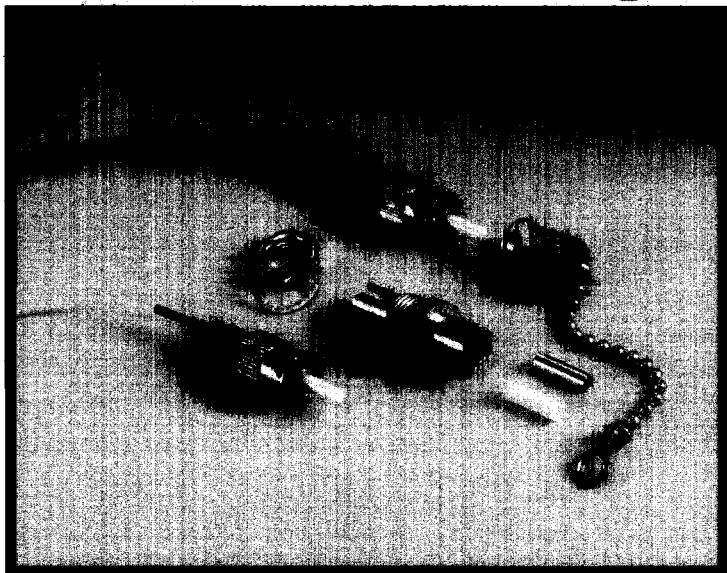

Applications

- ◆ Local Area Networks
- ◆ Premise Distribution
- ◆ Computer Peripheral Interconnections
- ◆ Telecommunication Networks
- ◆ Test and Instrumentation

The 953 series single mode and multimode connectors and adapters are precision ST II compatible interfaces manufactured to exceed industry performance specifications.

Features:

- The connector body and coupling nut are precision zinc die cast and nickel plated for superior strength and corrosion resistance. The enclosed spiral slotted coupling nut allows for easy mating in densely packed patch panels.
- The highly concentric precision zirconia ceramic ferrules are pre-radiused to minimize insertion loss and back reflection.
- All connectors are supplied with a 3mm diameter bend relief boot and a 900 μm bare fiber bend relief boot.
- The connectors utilize a crimp-on cable retention system for ease of termination and superior load carrying ability.
- Nickel plated zinc die cast ST adapters are available with either a high precision zirconia ceramic or a multimode phosphor bronze alignment sleeve for superior insertion loss performance.
- The 953 series connector can be field installed using the Amphenol Universal Termination Procedure (UTP) in five to seven minutes.

Specifications

Connection Loss:

- 9/125 μm fiber 0.19dB typical
- 62.5/125 μm fiber 0.13dB typical
- 50/125 μm fiber 0.14dB typical
- 100/140 μm fiber 0.10dB typical

Durability: $\leq 0.10\text{dB}$ change after 1000 mating cycles

Operating Temperature: -40°C to $+85^{\circ}\text{C}$

Intermateability:

Amphenol ST II compatible connectors and adapters are optically and mechanically compatible with AT&T ST, ST II connectors and their functional equivalents.

ST Connector 953-101-5306 (9/125 Fiber)

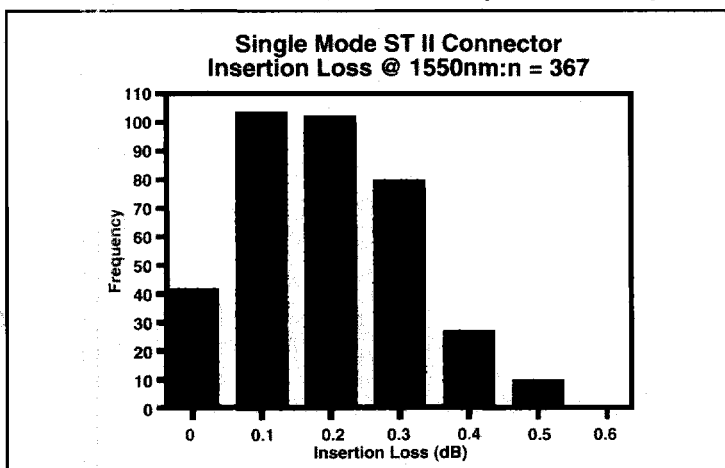

ST Connector 953-101-5310 (62.5/125 fiber)

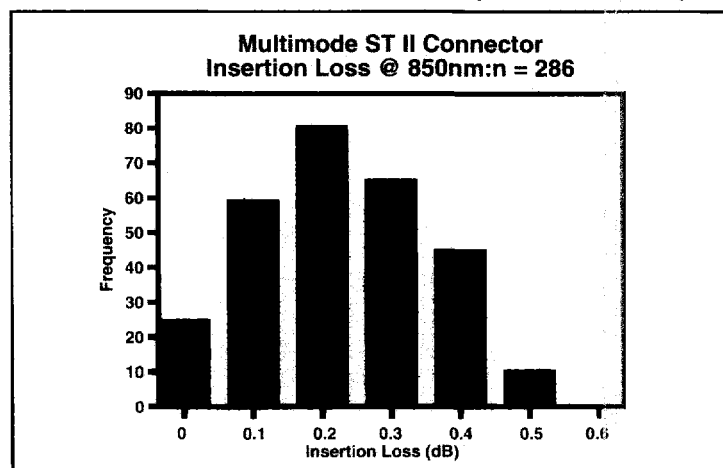

Order Information

Part Number	Description	Single Mode/Multimode
953-101-5305	ST Connector, Single Mode, 125 μm, Zirconia PC Ferrule, Die Cast	sm
953-101-5306	ST Connector, Single Mode, 126 μm, Zirconia PC Ferrule, Die Cast	sm
953-101-5307	ST Connector, Single Mode 127 μm, Zirconia PC Ferrule, Die Cast	sm
953-101-5308	ST Connector, Single Mode 128 μm, Zirconia PC Ferrule, Die Cast	sm
953-101-5310	ST Connector, Multimode 128 μm, Zirconia PC Ferrule, Die Cast	mm
953-101-5311	ST Connector, Multimode 144 μm, Zirconia PC Ferrule, Die Cast	mm
953-120-5003	ST Adapter, Die Cast, Phosphor Bronze Alignment Sleeve	mm
953-122-5003	ST Adapter, Die Cast, Zirconia Ceramic Alignment Sleeve	sm/mm
953-1061	ST Dust Cap and Chain	
927-100-5041	ST Designer's Kit	

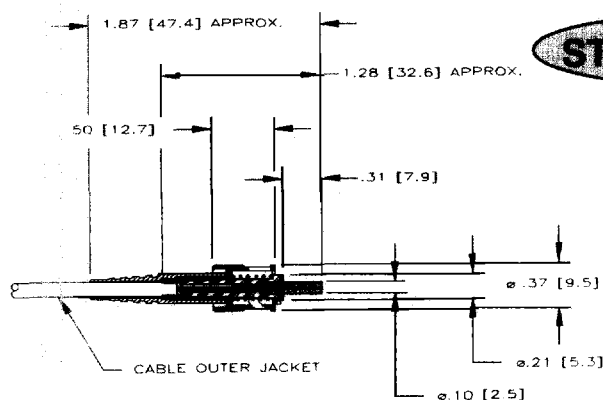

ST II Connector

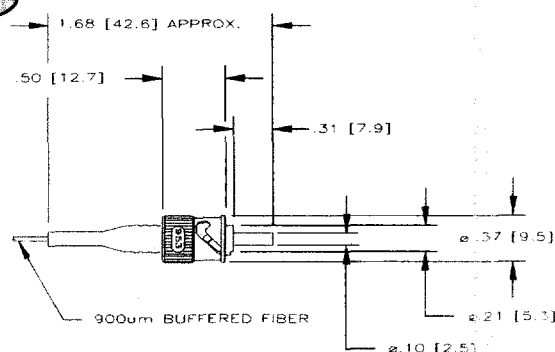

ST II Adapter

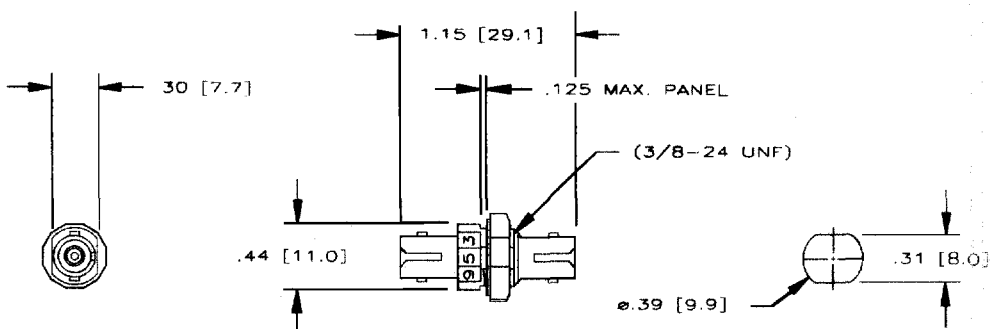

ST II Dust Cap

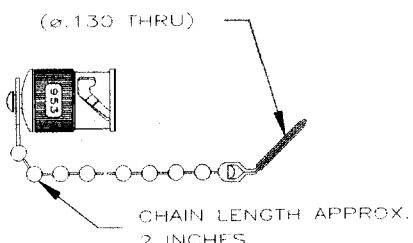

Amphenol Fiber Optic Products
 1925A Ohio Street
 Lisle, Illinois 60532
 Tel: (630) 810-5800 or (800) 944-6446
 Fax: (630) 810-5640

International Offices
 Australia (61 8) 341 0665
 Austria (43 1) 985 1511
 Belgium (32) 2 360 2366
 Canada (416) 291 4401
 England (44 1227) 773 200

France (33) 1 490 053000
 Germany (49) 7131 9290
 Hong Kong (852 2) 699 2663
 India (91 212) 790 363
 Italy (39 2) 939 04192

Japan (81 3) 3263 5611
 Netherlands (31) 30 63 58019
 Singapore (65) 743 3022
 Sweden (46) 859 077100
 Taiwan (886 3) 379 5677

Notice: Specifications are subject to change without notice. Contact your nearest Amphenol sales office for the latest specification. All statements, information and data given herein are believed to be accurate and reliable but are presented without guarantee, warranty or responsibility of any kind, express or implied. Statements or suggestions concerning possible use of our products are made without representation or warranty that any such use is free of patent infringement and are not recommendations to infringe any patent. The user should not assume that all safety measures are indicated or that other measures may not be required. **Amphenol** is a registered trademark.



Amphenol®
 Fiber Optic Products

Illuminating the world of fiber optics™