

# MH8S64PHC -7,-8,-10

536870912-BIT (8388608 - WORD BY 64-BIT) Synchronous DRAM

## DESCRIPTION

The MH8S64PHC is 8388608 - word by 64-bit Synchronous DRAM module. This consists of four industry standard 8Mx16 Synchronous DRAMs in TSOP and one industry standard EEPROM in TSSOP.

The mounting of TSOP on a card edge Dual Inline package provides any application where high densities and large quantities of memory are required.

This is a socket type - memory modules, suitable for easy interchange or addition of modules.

## FEATURES

	Frequency	CLK Access Time (Component SDRAM)
-7	100MHz	6.0ns(CL=3)
-8	100MHz	6.0ns(CL=3)
-10	100MHz	8.0ns(CL=3)

- Utilizes industry standard 8M x 16 Synchronous DRAMs TSOP and industry standard EEPROM in TSSOP
- 168-pin (84-pin dual in-line package)
- single 3.3V±0.3V power supply
- Clock frequency 100MHz
- Fully synchronous operation referenced to clock rising edge
- 4 bank operation controlled by BA0,1(Bank Address)
- /CAS latency- 2/3(programmable)
- Burst length- 1/2/4/8/Full Page(programmable)
- Burst type- sequential / interleave(programmable)
- Column access - random
- Auto precharge / All bank precharge controlled by A10
- Auto refresh and Self refresh
- 4096 refresh cycle /64ms
- LVTTTL Interface
- Discrete IC and module design conform to PC100 specification.  
(module Spec. Rev. 1.0 and SPD 1.2A(-7,-8), SPD1.0(-10))

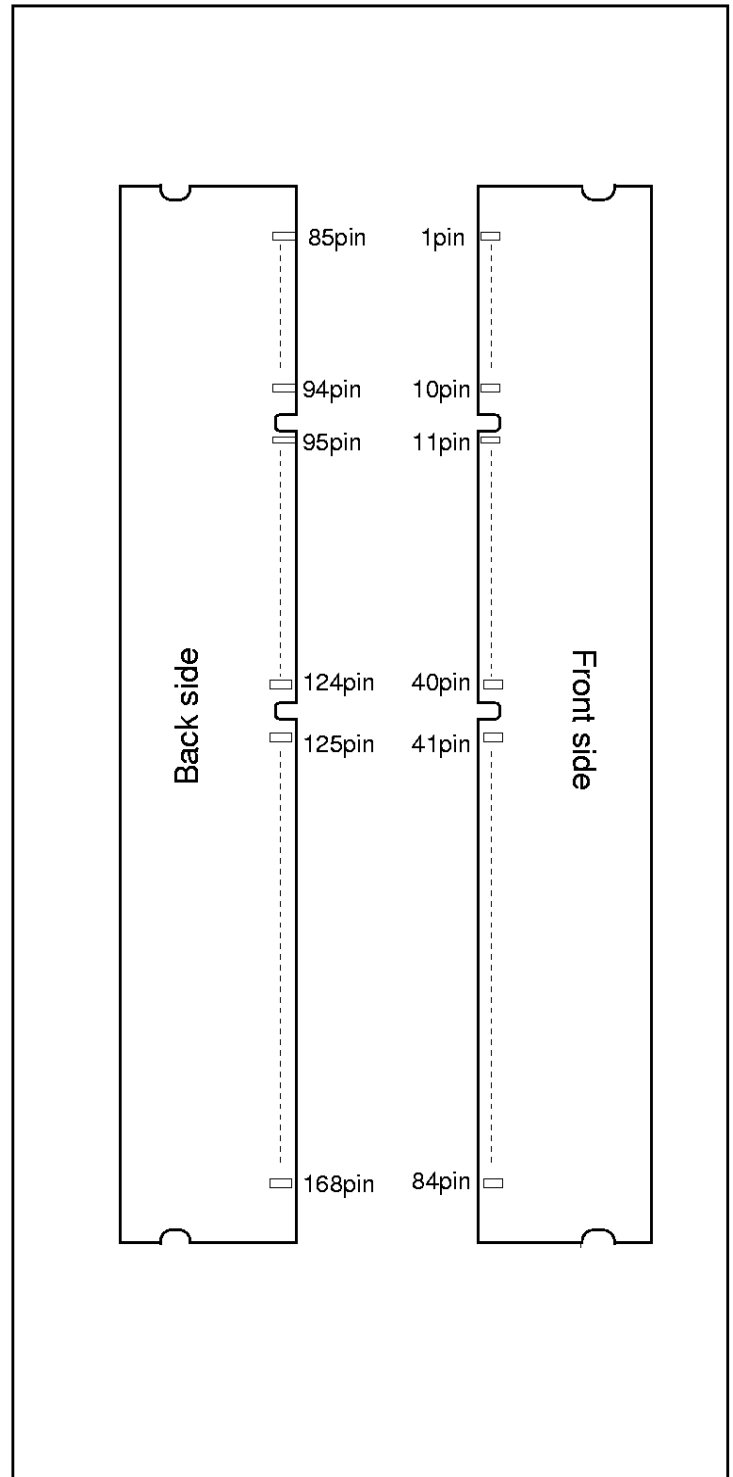

## APPLICATION

PC main memory

# MH8S64PHC -7,-8,-10

536870912-BIT (8388608 - WORD BY 64-BIT)SynchronousDRAM

PIN NO.	PIN NAME	PIN NO.	PIN NAME	PIN NO.	PIN NAME	PIN NO.	PIN NAME
1	VSS	43	VSS	85	VSS	127	VSS
2	DQ0	44	NC	86	DQ32	128	CKE0
3	DQ1	45	/S2	87	DQ33	129	NC
4	DQ2	46	DQMB2	88	DQ34	130	DQMB6
5	DQ3	47	DQMB3	89	DQ35	131	DQMB7
6	VDD	48	NC	90	VDD	132	NC
7	DQ4	49	VDD	91	DQ36	133	VDD
8	DQ5	50	NC	92	DQ37	134	NC
9	DQ6	51	NC	93	DQ38	135	NC
10	DQ7	52	NC	94	DQ39	136	NC
11	DQ8	53	NC	95	DQ40	137	NC
12	VSS	54	VSS	96	VSS	138	VSS
13	DQ9	55	DQ16	97	DQ41	139	DQ48
14	DQ10	56	DQ17	98	DQ42	140	DQ49
15	DQ11	57	DQ18	99	DQ43	141	DQ50
16	DQ12	58	DQ19	100	DQ44	142	DQ51
17	DQ13	59	VDD	101	DQ45	143	VDD
18	VDD	60	DQ20	102	VDD	144	DQ52
19	DQ14	61	NC	103	DQ46	145	NC
20	DQ15	62	NC	104	DQ47	146	NC
21	NC	63	NC	105	NC	147	NC
22	NC	64	VSS	106	NC	148	VSS
23	VSS	65	DQ21	107	VSS	149	DQ53
24	NC	66	DQ22	108	NC	150	DQ54
25	NC	67	DQ23	109	NC	151	DQ55
26	VDD	68	VSS	110	VDD	152	VSS
27	/WE0	69	DQ24	111	/CAS	153	DQ56
28	DQMB0	70	DQ25	112	DQMB4	154	DQ57
29	DQMB1	71	DQ26	113	DQMB5	155	DQ58
30	/S0	72	DQ27	114	NC	156	DQ59
31	NC	73	VDD	115	/RAS	157	VDD
32	VSS	74	DQ28	116	VSS	158	DQ60
33	A0	75	DQ29	117	A1	159	DQ61
34	A2	76	DQ30	118	A3	160	DQ62
35	A4	77	DQ31	119	A5	161	DQ63
36	A6	78	VSS	120	A7	162	VSS
37	A8	79	CK2	121	A9	163	CK3
38	A10	80	NC	122	BA0	164	NC
39	BA1	81	WP	123	A11	165	SA0
40	VDD	82	SDA	124	VDD	166	SA1
41	VDD	83	SCL	125	CK1	167	SA2
42	CK0	84	VDD	126	NC	168	VDD

NC = No Connection

# MH8S64PHC -7,-8,-10

536870912-BIT (8388608 - WORD BY 64-BIT) Synchronous DRAM

## Block Diagram

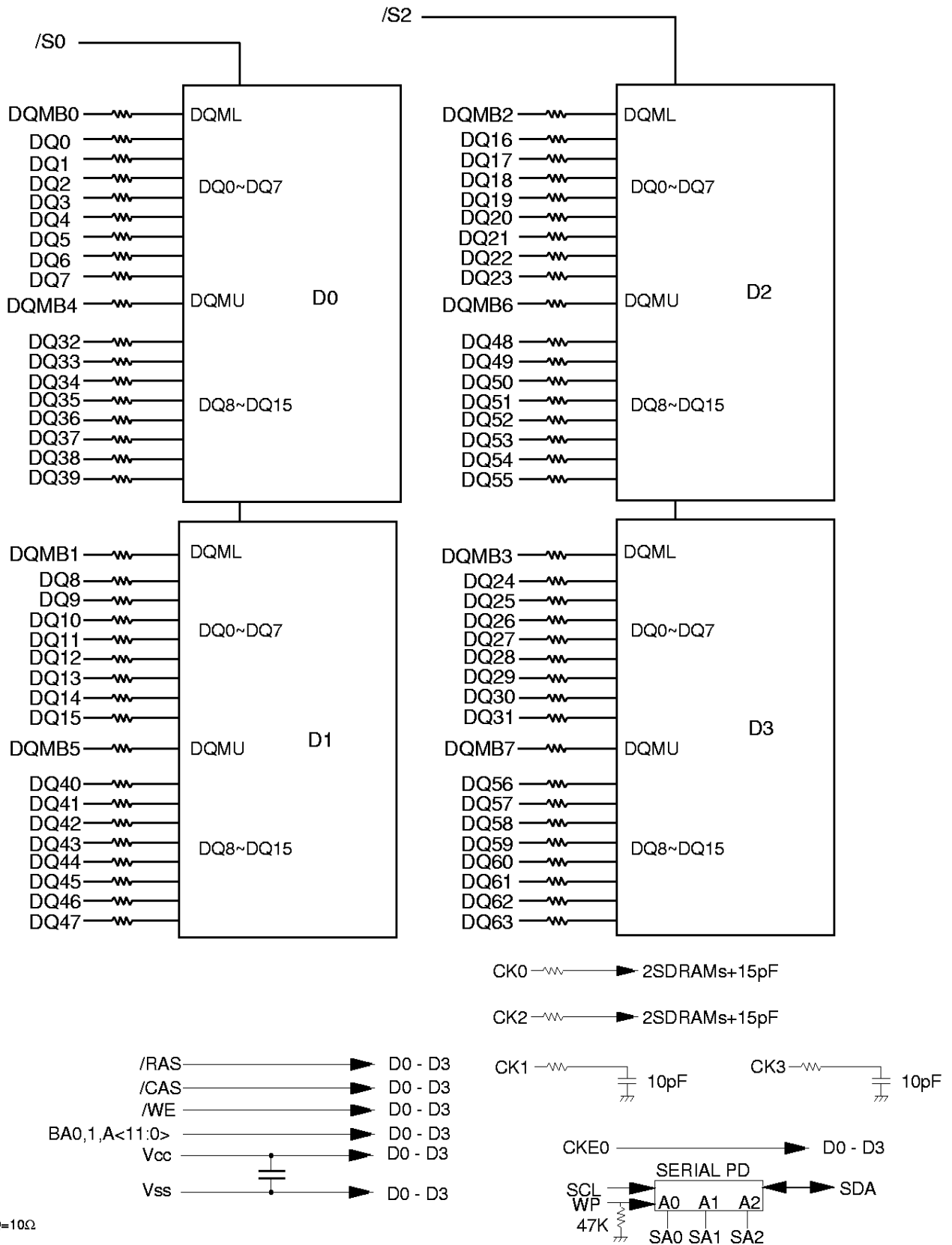

# MH8S64PHC -7,-8,-10

536870912-BIT (8388608 - WORD BY 64-BIT)SynchronousDRAM

## Serial Presence Detect Table I

Byte	Function described	SPD entry data	SPD DATA(hex)
0	Defines # bytes written into serial memory at module mfg	128	80
1	Total # bytes of SPD memory device	256 Bytes	08
2	Fundamental memory type	SDRAM	04
3	# Row Addresses on this assembly	A0-A11	0C
4	# Column Addresses on this assembly	A0-A8	09
5	# Module Banks on this assembly	1BANK	01
6	Data Width of this assembly...	x64	40
7	... Data Width continuation	0	00
8	Voltage interface standard of this assembly	LVTTTL	01
9	SDRAM Cycletime at Max. Supported CAS Latency (CL) Cycle time for CL=3	-7,-8,-10 10ns	A0
10	SDRAM Access from Clock tAC for CL=3	-7,-8 6ns	60
		-10 8ns	80
11	DIMM Configuration type (Non-parity,Parity,ECC)	Non-PARITY	00
12	Refresh Rate/Type	self refresh(15.625uS)	80
13	SDRAM width,Primary DRAM	x16	10
14	Error Checking SDRAM data width	N/A	00
15	Minimum Clock Delay,Back to Back Random Column Addresses	1	01
16	Burst Lengths Supported	1/2/4/8/Full page	8F
17	# Banks on Each SDRAM device	4bank	04
18	CAS# Latency	2/3	06
19	CS# Latency	0	01
20	Write Latency	0	01
21	SDRAM Module Attributes	non-buffered,non-registered	00
22	SDRAM Device Attributes:General	Precharge All,Auto precharge	0E
23	SDRAM Cycle time(2nd highest CAS latency) Cycle time for CL=2	-7 10ns	A0
		-8 13ns	D0
		-10 15ns	F0
24	SDRAM Access form Clock(2nd highest CAS latency) tAC for CL=2	-7 6ns	60
		-8 7ns	70
		-10 8ns	80
25	SDRAM Cycle time(3rd highest CAS latency)	N/A	00
26	SDRAM Access form Clock(3rd highest CAS latency)	N/A	00
27	Precharge to Active Minimum	-7,-8 20ns	14
		-10 30ns	1E
28	Row Active to Row Active Min.	-7,-8,-10 20ns	14
29	RAS to CAS Delay Min	-7,-8 20ns	14
		-10 30ns	1E
30	Active to Precharge Min	-7,-8 50ns	32
		-10 60ns	3C

# MH8S64PHC -7,-8,-10

536870912-BIT (8388608 - WORD BY 64-BIT)SynchronousDRAM

## Serial Presence Detect Table II

31	Density of each bank on module		64MByte	10
32	Command and Address signal input setup time	-7,-8	2ns	20
		-10	N/A	00
33	Command and Address signal input hold time	-7,-8	1ns	10
		-10	N/A	00
34	Data signal input setup time	-7,-8	2ns	20
		-10	N/A	00
35	Data signal input hold time	-7,-8	1ns	10
		-10	N/A	00
36-61	Superset Information (may be used in future)		option	00
62	SPD Revision	-7,-8	rev 1.2A	12
		-10	rev 1	01
63	Checksum for bytes 0-62		Check sum for -7	0D
			Check sum for -8	4D
			Check sum for -10	4A
64-71	Manufactures Jedec ID code per JEP-108E		MITSUBISHI	1CFFFFFFFFFFFFFF
72	Manufacturing location		Miyoshi,Japan	01
			Tajima,Japan	02
			NC,USA	03
			Germany	04
73-90	Manufactures Part Number		MH8S64PHC-7	4D48385336345048432D37202020202020
			MH8S64PHC-8	4D48385336345048432D38202020202020
			MH8S64PHC-10	4D48385336345048432D31302020202020
91-92	Revision Code		PCB revision	rrrr
93-94	Manufacturing date		year/week code	yyww
95-98	Assembly Serial Number		serial number	ssssssss
99-125	Manufacture Specific Data		option	00
126	Intel specification frequency	-7,-8	100MHz	64
		-10	66MHz	66
127	Intel specification CAS# Latency support	-7	CL=2/3,AP,CK0,2	AF
		-8	CL=3,AP,CK0,2	AD
		-10	CL=2/3	06
128+	Unused storage locations		open	00

## MH8S64PHC -7,-8,-10

536870912-BIT (8388608 - WORD BY 64-BIT)SynchronousDRAM

**PIN FUNCTION**

CK (CK0,2)	Input	Master Clock:All other inputs are referenced to the rising edge of CK
CKE0	Input	Clock Enable:CKE controls internal clock.When CKE is low,internal clock for the following cycle is ceased. CKE is also used to select auto / self refresh. After self refresh mode is started, CKE becomes asynchronous input.Self refresh is maintained as long as CKE is low.
/S (/S0,2)	Input	Chip Select: When /S is high,any command means No Operation.
/RAS,/CAS,/WE	Input	Combination of /RAS,/CAS,/WE defines basic commands.
A0-11	Input	A0-11 specify the Row/Column Address in conjunction with BA.The Row Address is specified by A0-11.The Column Address is specified by A0-8.A10 is also used to indicate precharge option.When A10 is high at a read / write command, an auto precharge is performed. When A10 is high at a precharge command, both banks are precharged.
BA0,1	Input	Bank Address:BA0,1 is not simply BA.BA0,1 specifies the bank to which a command is applied.BA0,1 must be set with ACT,PRE,READ,WRITE commands
DQ0-63	Input/Output	Data In and Data out are referenced to the rising edge of CK
DQMB0-7	Input	Din Mask/Output Disable:When DQMB is high in burst write.Din for the current cycle is masked.When DQMB is high in burst read,Dout is disabled at the next but one cycle.
Vdd,Vss	Power Supply	Power Supply for the memory mounted module.
SCL	Input	Serial clock for serial PD
SDA	Output	Serial data for serial PD
SA0-3	Input	Address input for serial PD

# MH8S64PHC -7,-8,-10

536870912-BIT (8388608 - WORD BY 64-BIT)SynchronousDRAM

## BASIC FUNCTIONS

The MH8S64PHC provides basic functions, bank(row) activate, burst read / write, bank(row) precharge, and auto / self refresh.

Each command is defined by control signals of /RAS, /CAS and /WE at CK rising edge. In addition to 3 signals, /S, CKE and A10 are used as chip select, refresh option, and precharge option, respectively.

To know the detailed definition of commands please see the command truth table.

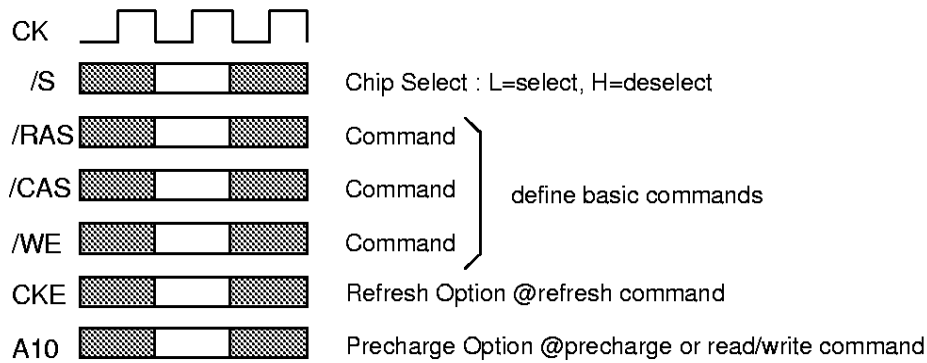

### Activate(ACT) [/RAS =L, /CAS = /WE =H]

ACT command activates a row in an idle bank indicated by BA0,1.

### Read(READ) [/RAS =H, /CAS =L, /WE =H]

READ command starts burst read from the active bank indicated by BA0,1. First output data appears after /CAS latency. When A10 =H at this command, the bank is deactivated after the burst read(auto-precharge, **READA**).

### Write(WRITE) [/RAS =H, /CAS = /WE =L]

WRITE command starts burst write to the active bank indicated by BA0,1. Total data length to be written is set by burst length. When A10 =H at this command, the bank is deactivated after the burst write(auto-precharge, **WRITEA**).

### Precharge(PRE) [/RAS =L, /CAS =H, /WE =L]

PRE command deactivates the active bank indicated by BA0,1. This command also terminates burst read / write operation. When A10 =H at this command, both banks are deactivated(precharge all, **PREA**).

### Auto-Refresh(REFA) [/RAS =/CAS =L, /WE =CKE =H]

REFA command starts auto-refresh cycle. Refresh address including bank address are generated internally. After this command, the banks are precharged automatically.

# MH8S64PHC -7,-8,-10

536870912-BIT (8388608 - WORD BY 64-BIT)SynchronousDRAM

## COMMAND TRUTH TABLE

COMMAND	MNEMONIC	CKE <sub>n-1</sub>	CKE <sub>n</sub>	/S	/RAS	/CAS	/WE	BA0,1	A11	A10	A0-9
Deselect	DESEL	H	X	H	X	X	X	X	X	X	X
No Operation	NOP	H	X	L	H	H	H	X	X	X	X
Row Adress Entry & Bank Activate	ACT	H	X	L	L	H	H	V	V	V	V
Single Bank Precharge	PRE	H	X	L	L	H	L	V	X	L	X
Precharge All Bank	PREA	H	X	L	L	H	L	X	X	H	X
Column Address Entry & Write	WRITE	H	X	L	H	L	L	V	X	L	V
Column Address Entry & Write with Auto-Precharge	WRITEA	H	X	L	H	L	L	V	X	H	V
Column Address Entry & Read	READ	H	X	L	H	L	H	V	X	L	V
Column Address Entry & Read with Auto Precharge	READA	H	X	L	H	L	H	V	X	H	V
Auto-Refresh	REFA	H	H	L	L	L	H	X	X	X	X
Self-Refresh Entry	REFS	H	L	L	L	L	H	X	X	X	X
Self-Refresh Exit	REFSX	L	H	H	X	X	X	X	X	X	X
		L	H	L	H	H	H	X	X	X	X
Burst Terminate	TERM	H	X	L	H	H	L	X	X	X	X
Mode Register Set	MRS	H	X	L	L	L	L	L	L	L	V*1

H =High Level, L = Low Level, V = Valid, X = Don't Care, n = CK cycle number

**NOTE:**

1.A7-9 = 0, A0-6 = Mode Address

# MH8S64PHC -7,-8,-10

536870912-BIT (8388608 - WORD BY 64-BIT)SynchronousDRAM

## FUNCTION TRUTH TABLE

Current State	/S	/RAS	/CAS	/WE	Address	Command	Action
IDLE	H	X	X	X	X	DESEL	NOP
	L	H	H	H	X	NOP	NOP
	L	H	H	L	BA	TBST	ILLEGAL*2
	L	H	L	X	BA,CA,A10	READ/WRITE	ILLEGAL*2
	L	L	H	H	BA,RA	ACT	Bank Active,Latch RA
	L	L	H	L	BA,A10	PRE/PREA	NOP*4
	L	L	L	H	X	REFA	Auto-Refresh*5
	L	L	L	L	Op-Code, Mode-Add	MRS	Mode Register Set*5
ROW ACTIVE	H	X	X	X	X	DESEL	NOP
	L	H	H	H	X	NOP	NOP
	L	H	H	L	BA	TBST	NOP
	L	H	L	H	BA,CA,A10	READ/READA	Begin Read,Latch CA, Determine Auto-Precharge
	L	H	L	L	BA,CA,A10	WRITE/ WRITEA	Begin Write,Latch CA, Determine Auto-Precharge
	L	L	H	H	BA,RA	ACT	Bank Active/ILLEGAL*2
	L	L	H	L	BA,A10	PRE/PREA	Precharge/Precharge All
	L	L	L	H	X	REFA	ILLEGAL
	L	L	L	L	Op-Code, Mode-Add	MRS	ILLEGAL
READ	H	X	X	X	X	DESEL	NOP(Continue Burst to END)
	L	H	H	H	X	NOP	NOP(Continue Burst to END)
	L	H	H	L	BA	TBST	Terminate Burst
	L	H	L	H	BA,CA,A10	READ/READA	Terminate Burst,Latch CA, Begin New Read,Determine Auto-Precharge*3
	L	H	L	L	BA,CA,A10	WRITE/WRITEA	Terminate Burst,Latch CA, Begin Write,Determine Auto- Precharge*3
	L	L	H	H	BA,RA	ACT	Bank Active/ILLEGAL*2
	L	L	H	L	BA,A10	PRE/PREA	Terminate Burst,Precharge
	L	L	L	H	X	REFA	ILLEGAL
	L	L	L	L	Op-Code, Mode-Add	MRS	ILLEGAL

# MH8S64PHC -7,-8,-10

536870912-BIT (8388608 - WORD BY 64-BIT)SynchronousDRAM

## FUNCTION TRUTH TABLE(continued)

Current State	/S	/RAS	/CAS	/WE	Address	Command	Action
WRITE	H	X	X	X	X	DESEL	NOP(Continue Burst to END)
	L	H	H	H	X	NOP	NOP(Continue Burst to END)
	L	H	H	L	BA	TBST	Terminate Burst
	L	H	L	H	BA,CA,A10	READ/READA	Terminate Burst,Latch CA, Begin Read,Determine Auto-Precharge*3
	L	H	L	L	BA,CA,A10	WRITE/ WRITEA	Terminate Burst,Latch CA, Begin Write,Determine Auto-Precharge*3
	L	L	H	H	BA,RA	ACT	Bank Active/ILLEGAL*2
	L	L	H	L	BA,A10	PRE/PREA	Terminate Burst,Precharge
	L	L	L	H	X	REFA	ILLEGAL
	L	L	L	L	Op-Code, Mode-Add	MRS	ILLEGAL
READ with AUTO PRECHARGE	H	X	X	X	X	DESEL	NOP(Continue Burst to END)
	L	H	H	H	X	NOP	NOP(Continue Burst to END)
	L	H	H	L	BA	TBST	ILLEGAL
	L	H	L	H	BA,CA,A10	READ/READA	ILLEGAL
	L	H	L	L	BA,CA,A10	WRITE/ WRITEA	ILLEGAL
	L	L	H	H	BA,RA	ACT	Bank Active/ILLEGAL*2
	L	L	H	L	BA,A10	PRE/PREA	ILLEGAL*2
	L	L	L	H	X	REFA	ILLEGAL
	L	L	L	L	Op-Code, Mode-Add	MRS	ILLEGAL
WRITE with AUTO PRECHARGE	H	X	X	X	X	DESEL	NOP(Continue Burst to END)
	L	H	H	H	X	NOP	NOP(Continue Burst to END)
	L	H	H	L	BA	TBST	ILLEGAL
	L	H	L	H	BA,CA,A10	READ/READA	ILLEGAL
	L	H	L	L	BA,CA,A10	WRITE/ WRITEA	ILLEGAL
	L	L	H	H	BA,RA	ACT	Bank Active/ILLEGAL*2
	L	L	H	L	BA,A10	PRE/PREA	ILLEGAL*2
	L	L	L	H	X	REFA	ILLEGAL
	L	L	L	L	Op-Code, Mode-Add	MRS	ILLEGAL

# MH8S64PHC -7,-8,-10

536870912-BIT (8388608 - WORD BY 64-BIT)SynchronousDRAM

## FUNCTION TRUTH TABLE(continued)

Current State	/S	/RAS	/CAS	/WE	Address	Command	Action
PRE - CHARGING	H	X	X	X	X	DESEL	NOP(Idle after tRP)
	L	H	H	H	X	NOP	NOP(Idle after tRP)
	L	H	H	L	BA	TBST	ILLEGAL*2
	L	H	L	X	BA,CA,A10	READ/WRITE	ILLEGAL*2
	L	L	H	H	BA,RA	ACT	ILLEGAL*2
	L	L	H	L	BA,A10	PRE/PREA	NOP*4(Idle after tRP)
	L	L	L	H	X	REFA	ILLEGAL
	L	L	L	L	Op-Code, Mode-Add	MRS	ILLEGAL
ROW ACTIVATING	H	X	X	X	X	DESEL	NOP(Row Active after tRCD)
	L	H	H	H	X	NOP	NOP(Row Active after tRCD)
	L	H	H	L	BA	TBST	ILLEGAL*2
	L	H	L	X	BA,CA,A10	READ/WRITE	ILLEGAL*2
	L	L	H	H	BA,RA	ACT	ILLEGAL*2
	L	L	H	L	BA,A10	PRE/PREA	ILLEGAL*2
	L	L	L	H	X	REFA	ILLEGAL
	L	L	L	L	Op-Code, Mode-Add	MRS	ILLEGAL
WRITE RE- COVERING	H	X	X	X	X	DESEL	NOP
	L	H	H	H	X	NOP	NOP
	L	H	H	L	BA	TBST	ILLEGAL*2
	L	H	L	X	BA,CA,A10	READ/WRITE	ILLEGAL*2
	L	L	H	H	BA,RA	ACT	ILLEGAL*2
	L	L	H	L	BA,A10	PRE/PREA	ILLEGAL*2
	L	L	L	H	X	REFA	ILLEGAL
	L	L	L	L	Op-Code, Mode-Add	MRS	ILLEGAL

# MH8S64PHC -7,-8,-10

536870912-BIT (8388608 - WORD BY 64-BIT)SynchronousDRAM

## FUNCTION TRUTH TABLE(continued)

Current State	/S	/RAS	/CAS	/WE	Address	Command	Action
RE-FRESHING	H	X	X	X	X	DESEL	NOP(Idle after tRC)
	L	H	H	H	X	NOP	NOP(Idle after tRC)
	L	H	H	L	BA	TBST	ILLEGAL
	L	H	L	X	BA,CA,A10	READ/WRITE	ILLEGAL
	L	L	H	H	BA,RA	ACT	ILLEGAL
	L	L	H	L	BA,A10	PRE/PREA	ILLEGAL
	L	L	L	H	X	REFA	ILLEGAL
	L	L	L	L	Op-Code, Mode-Add	MRS	ILLEGAL
MODE REGISTER SETTING	H	X	X	X	X	DESEL	NOP(Idle after tRSC)
	L	H	H	H	X	NOP	NOP(Idle after tRSC)
	L	H	H	L	BA	TBST	ILLEGAL
	L	H	L	X	BA,CA,A10	READ/WRITE	ILLEGAL
	L	L	H	H	BA,RA	ACT	ILLEGAL
	L	L	H	L	BA,A10	PRE/PREA	ILLEGAL
	L	L	L	H	X	REFA	ILLEGAL
	L	L	L	L	Op-Code, Mode-Add	MRS	ILLEGAL

### ABBREVIATIONS:

H = High Level, L = Low Level, X = Don't Care

BA = Bank Address, RA = Row Address, CA = Column Address, NOP = No Operation

### NOTES:

1. All entries assume that CKE was High during the preceding clock cycle and the current clock cycle.
2. ILLEGAL to bank in specified state; function may be legal in the bank indicated by BA, depending on the state of that bank.
3. Must satisfy bus contention, bus turn around, write recovery requirements.
4. NOP to bank precharging or in idle state. May precharge bank indicated by BA.
5. ILLEGAL if any bank is not idle.

ILLEGAL = Device operation and / or data-integrity are not guaranteed.

## FUNCTION TRUTH TABLE FOR CKE

Current State	CKE <sub>n-1</sub>	CKE <sub>n</sub>	/S	/RAS	/CAS	/WE	Add	Action
SELF - REFRESH*1	H	X	X	X	X	X	X	INVALID
	L	H	H	X	X	X	X	Exit Self-Refresh(Idle after tRC)
	L	H	L	H	H	H	X	Exit Self-Refresh(Idle after tRC)
	L	H	L	H	H	L	X	ILLEGAL
	L	H	L	H	L	X	X	ILLEGAL
	L	H	L	L	X	X	X	ILLEGAL
	L	L	X	X	X	X	X	NOP(Maintain Self-Refresh)
POWER DOWN	H	X	X	X	X	X	X	INVALID
	L	H	X	X	X	X	X	Exit Power Down to Idle
	L	L	X	X	X	X	X	NOP(Maintain Self-Refresh)
ALL BANKS IDLE*2	H	H	X	X	X	X	X	Refer to Function Truth Table
	H	L	L	L	L	H	X	Enter Self-Refresh
	H	L	H	X	X	X	X	Enter Power Down
	H	L	L	H	H	H	X	Enter Power Down
	H	L	L	H	H	L	X	ILLEGAL
	H	L	L	H	L	X	X	ILLEGAL
	H	L	L	L	X	X	X	ILLEGAL
	L	X	X	X	X	X	X	Refer to Current State = Power Down
ANY STATE other than listed above	H	H	X	X	X	X	X	Refer to Function Truth Table
	H	L	X	X	X	X	X	Begin CK0 Suspend at Next Cycle*3
	L	H	X	X	X	X	X	Exit CK0 Suspend at Next Cycle*3
	L	L	X	X	X	X	X	Maintain CK0 Suspend

### ABBREVIATIONS:

H = High Level, L = Low Level, X = Don't Care

### NOTES:

1. CKE Low to High transition will re-enable CK and other inputs **asynchronously**. A minimum setup time must be satisfied before any command other than EXIT.
2. Power-Down and Self-Refresh can be entered only from the All banks idle State.
3. Must be legal command.



# MH8S64PHC -7,-8,-10

536870912-BIT (8388608 - WORD BY 64-BIT)SynchronousDRAM

## POWER ON SEQUENCE

Before starting normal operation, the following power on sequence is necessary to prevent a SDRAM from damaged or malfunctioning.

1. Apply power and start clock. Attempt to maintain CKE high, DQMB0-7 high and NOP condition at the inputs.
2. Maintain stable power, stable clock, and NOP input conditions for a minimum of 500us.
3. Issue precharge commands for all banks. (PRE or PREA)
4. After all banks become idle state (after tRP), issue 8 or more auto-refresh commands.
5. Issue a mode register set command to initialize the mode register.

After these sequence, the SDRAM is idle state and ready for normal operation.

## MODE REGISTER

Burst Length, Burst Type and /CAS Latency can be programmed by setting the mode register(MRS). The mode register stores these date until the next MRS command, which may be issue when both banks are in idle state. After tRSC from a MRS command, the SDRAM is ready for new command.

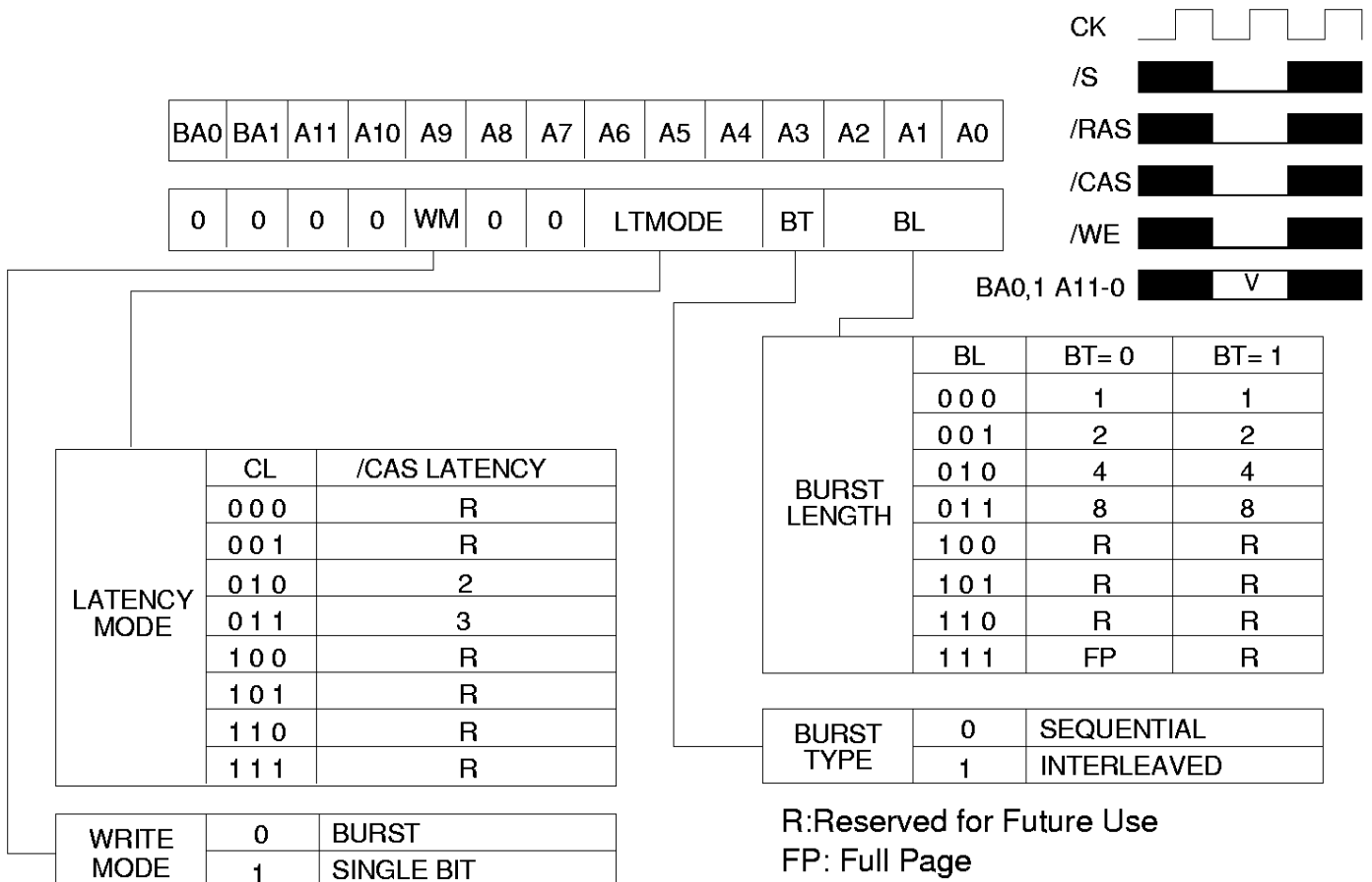

# MH8S64PHC -7,-8,-10

536870912-BIT (8388608 - WORD BY 64-BIT) Synchronous DRAM

## [ /CAS LATENCY ]

/CAS latency, CL, is used to synchronize the first output data with the CLK frequency, i.e., the speed of CLK determines which CL should be used. First output data is available after CL cycles from READ command.

/CAS Latency Timing (BL=4)

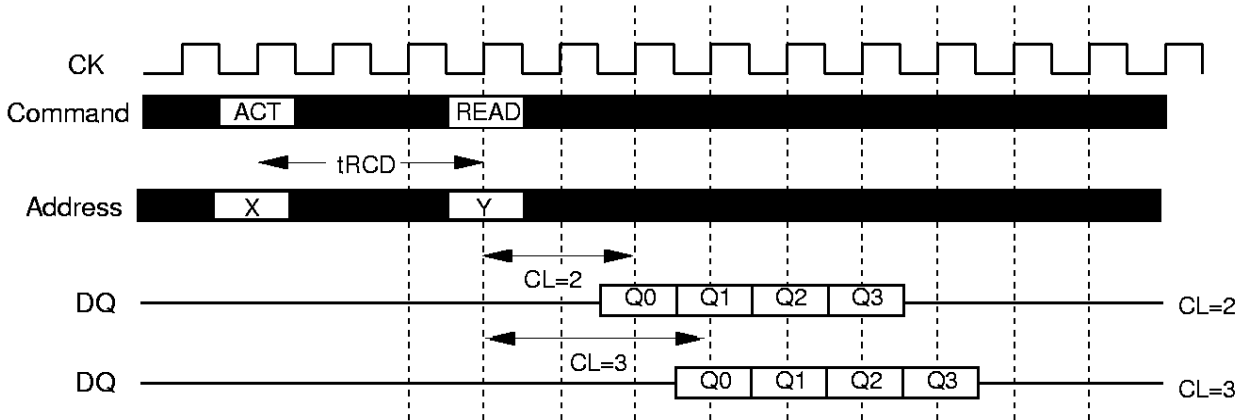

## [ BURST LENGTH ]

The burst length, BL, determines the number of consecutive writes or reads that will be automatically performed after the initial write or read command. For BL=1,2,4,8, full page the output data is tristated (Hi-Z) after the last read. For BL=FP (Full Page), the TBST (Burst Terminate) command should be issued to stop the output of data.

Burst Length Timing (CL=2)

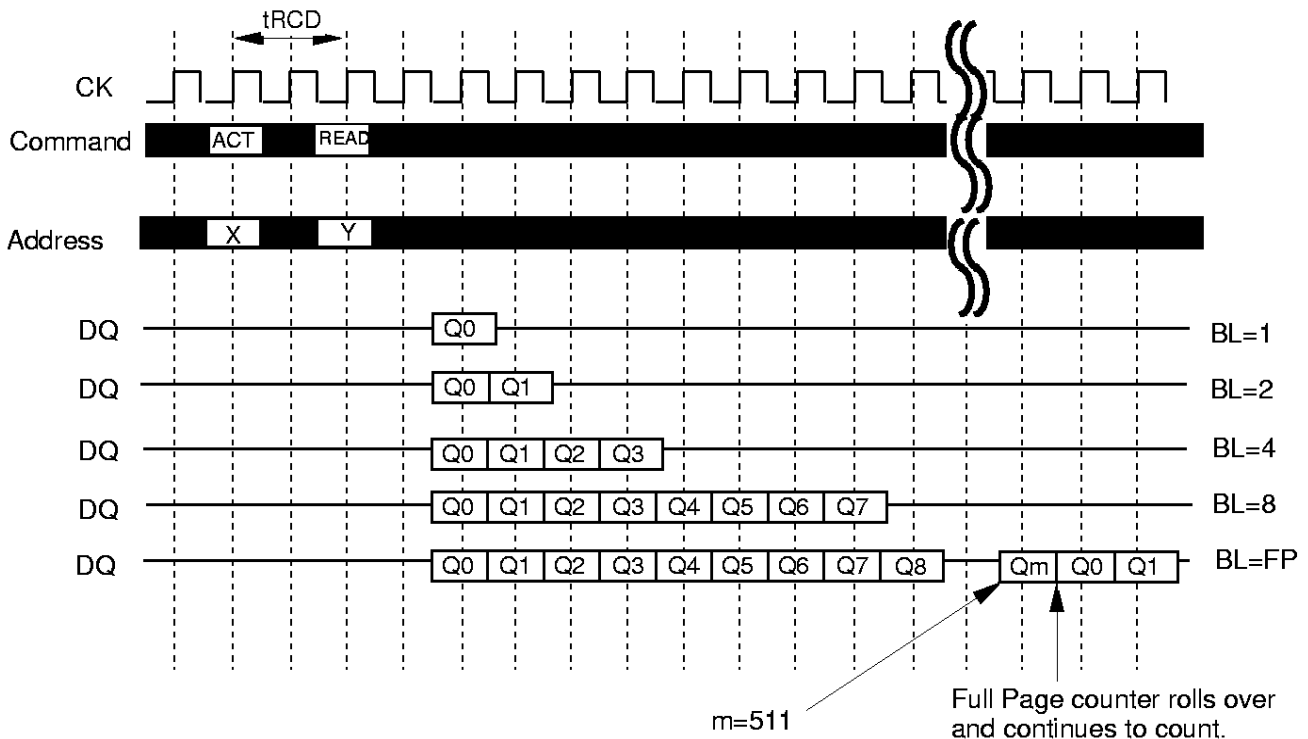

# MH8S64PHC -7,-8,-10

536870912-BIT (8388608 - WORD BY 64-BIT) Synchronous DRAM

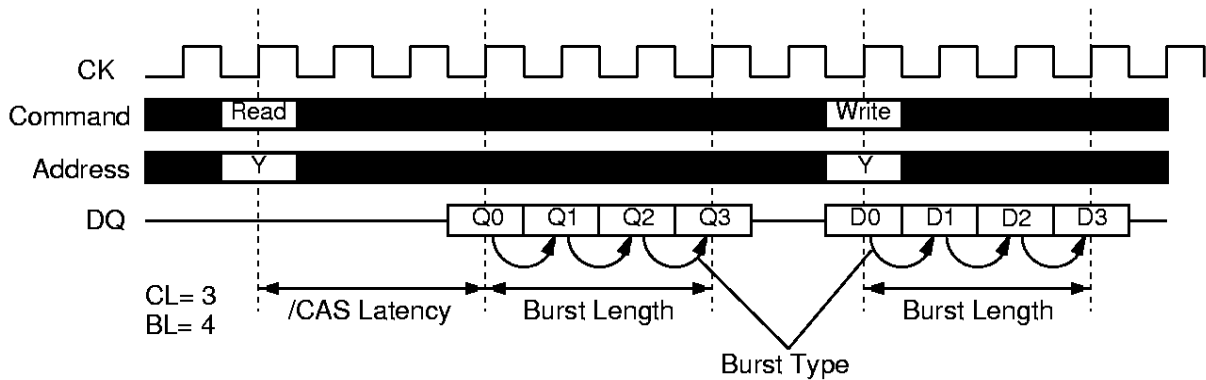

Initial Address			BL	Column Addressing															
A2	A1	A0		Sequential								Interleaved							
0	0	0	8	0	1	2	3	4	5	6	7	0	1	2	3	4	5	6	7
0	0	1		1	2	3	4	5	6	7	0	1	0	3	2	5	4	7	6
0	1	0		2	3	4	5	6	7	0	1	2	3	0	1	6	7	4	5
0	1	1		3	4	5	6	7	0	1	2	3	2	1	0	7	6	5	4
1	0	0		4	5	6	7	0	1	2	3	4	5	6	7	0	1	2	3
1	0	1		5	6	7	0	1	2	3	4	5	4	7	6	1	0	3	2
1	1	0		6	7	0	1	2	3	4	5	6	7	4	5	2	3	0	1
1	1	1		7	0	1	2	3	4	5	6	7	6	5	4	3	2	1	0
-	0	0	4	0	1	2	3					0	1	2	3				
-	0	1		1	2	3	0					1	0	3	2				
-	1	0		2	3	0	1					2	3	0	1				
-	1	1		3	0	1	2					3	2	1	0				
-	-	0	2	0	1							0	1						
-	-	1		1	0							1	0						

# MH8S64PHC -7,-8,-10

536870912-BIT (8388608 - WORD BY 64-BIT) Synchronous DRAM

## OPERATION DESCRIPTION

### BANK ACTIVATE

The SDRAM has four independent banks. Each bank is activated by the ACT command with the bank address (BA0,1). A row is indicated by the row address A11-0. The minimum activation interval between one bank and the other bank is  $t_{RRD}$ . The number of banks which are active concurrently is not limited.

### PRECHARGE

The PRE command deactivates indicated by BA. When both banks are active, the precharge all command (PREA, PRE + A10=H) is available to deactivate them at the same time. After  $t_{RP}$  from the precharge, an ACT command can be issued.

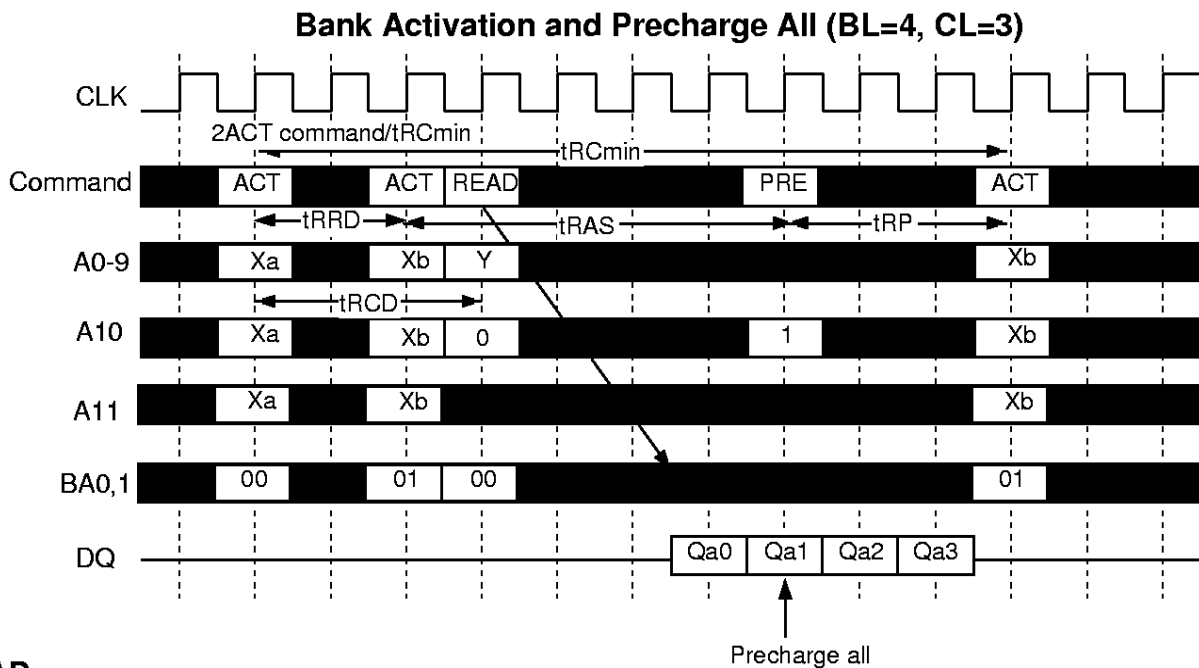

### READ

After  $t_{RCD}$  from the bank activation, a READ command can be issued. 1st output data is available after the /CAS Latency from the READ, followed by (BL-1) consecutive data when the Burst Length is BL. The start address is specified by A8-0, and the address sequence of burst data is defined by the Burst Type. A READ command may be applied to any active bank, so the row precharge time ( $t_{RP}$ ) can be hidden behind continuous output data (in case of BL=8) by interleaving the dual banks. When A10 is high at a READ command, the auto-precharge (READA) is performed. Any command (READ, WRITE, PRE, ACT) to the same bank is inhibited till the internal precharge is complete. The internal precharge start at BL after READA. The next ACT command can be issued after (BL +  $t_{RP}$ ) from the previous READA.

# MH8S64PHC -7,-8,-10

536870912-BIT (8388608 - WORD BY 64-BIT) Synchronous DRAM

## Multi Bank Interleaving READ (BL=4, CL=3)

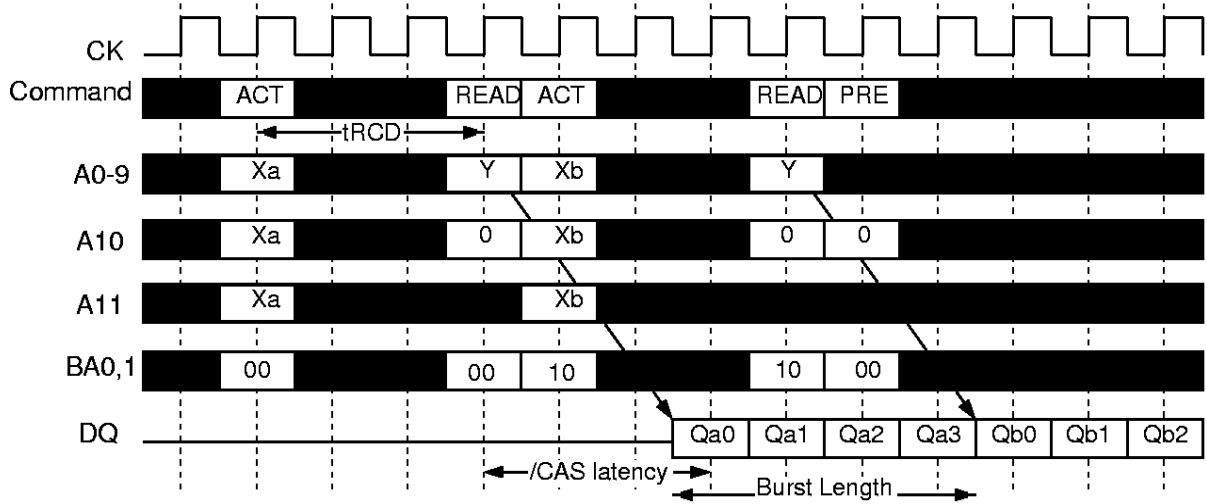

## READ with Auto-Precharge (BL=4, CL=3)

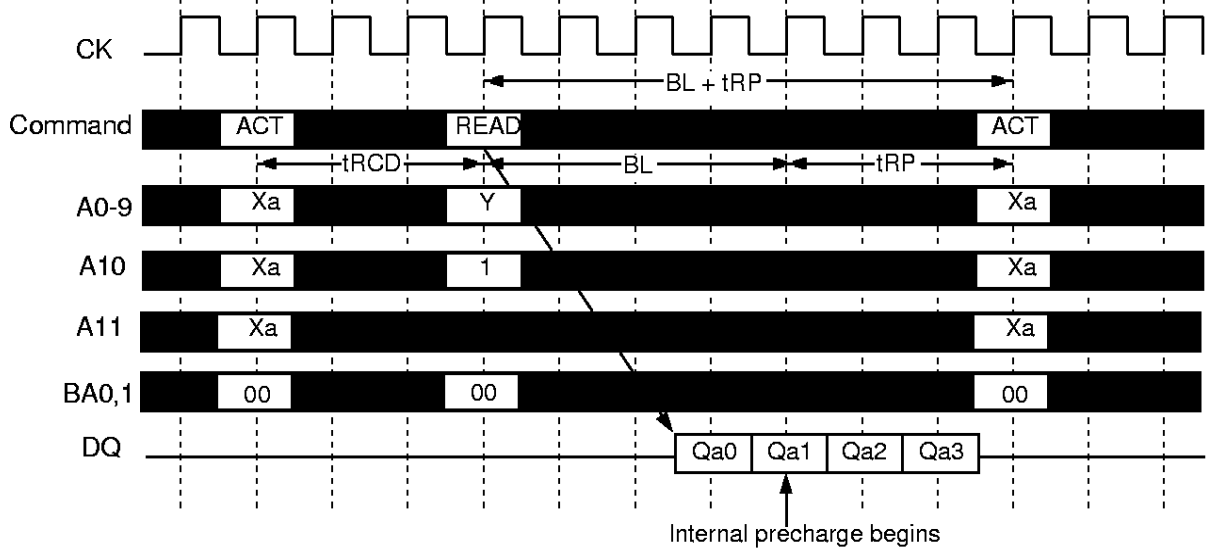

## READ Auto-Precharge Timing (BL=4)

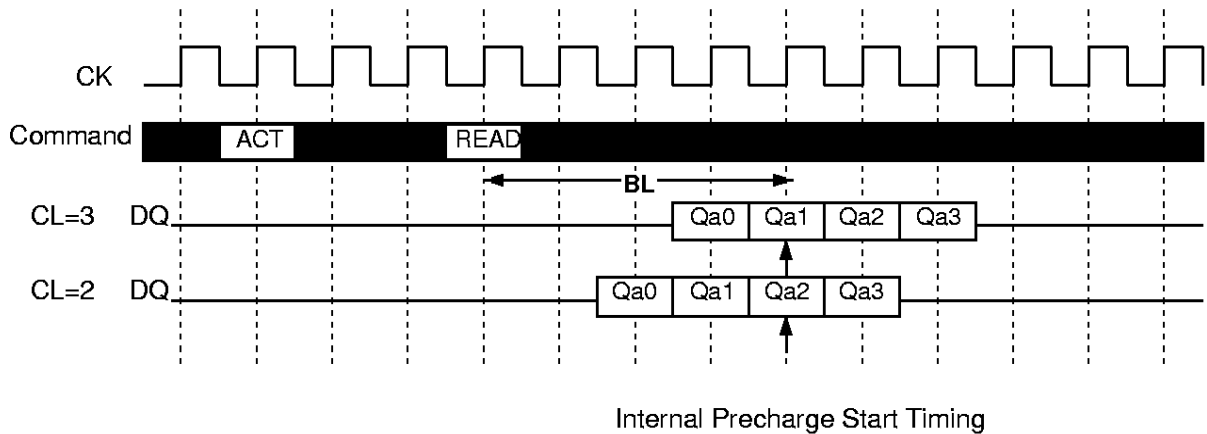

# MH8S64PHC -7,-8,-10

536870912-BIT (8388608 - WORD BY 64-BIT)SynchronousDRAM

## WRITE

After  $t_{RCD}$  from the bank activation, a WRITE command can be issued. 1st input data is set at the same cycle as the WRITE. Following(BL-1) data are written into the RAM, when the Burst Length is BL. The start address is specified by A8-0, and the address sequence of burst data is defined by the Burst Type. A WRITE command may be applied to any active bank, so the row precharge time( $t_{RP}$ ) can be hidden behind continuous input data by interleaving the multiple banks. From the last input data to the PRE command, the write recovery time ( $t_{WR}$ ) is required. When A10 is high at a WRITE command, the auto-precharge(WRITEA) is performed. Any command(READ, WRITE, PRE, ACT) to the same bank is inhibited till the internal precharge is complete. The internal precharge begins at  $t_{WR}$  after the last input data cycle. The next ACT command can be issued after  $t_{RP}$  from the internal precharge timing. The Mode Register can be WRITE command is issued and the remaining burst length is ignored. The read data burst length os unaffected while in this mode.

### Multi Bank Interleaving WRITE (BL=4)

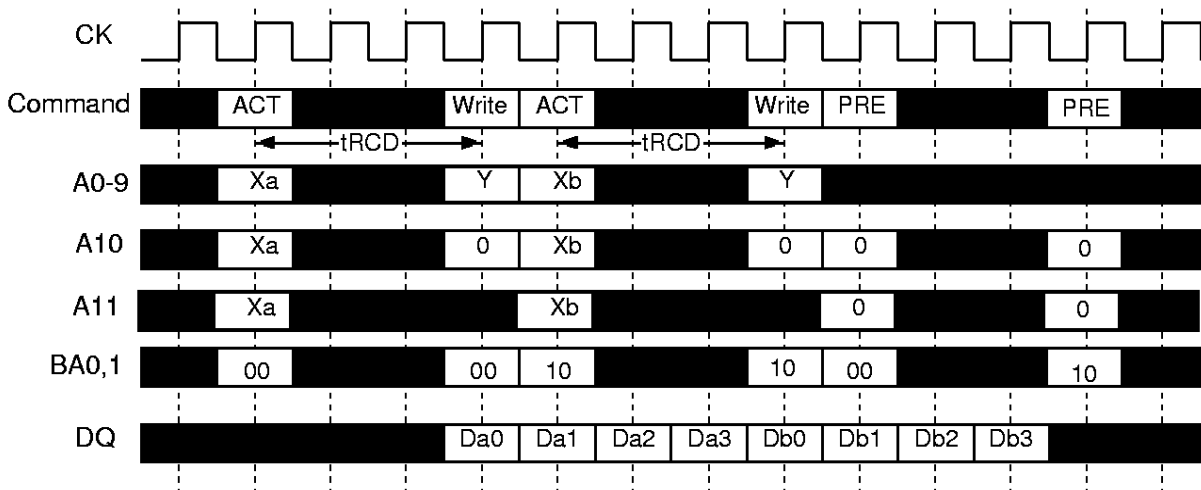

### WRITE with Auto-Precharge (BL=4)

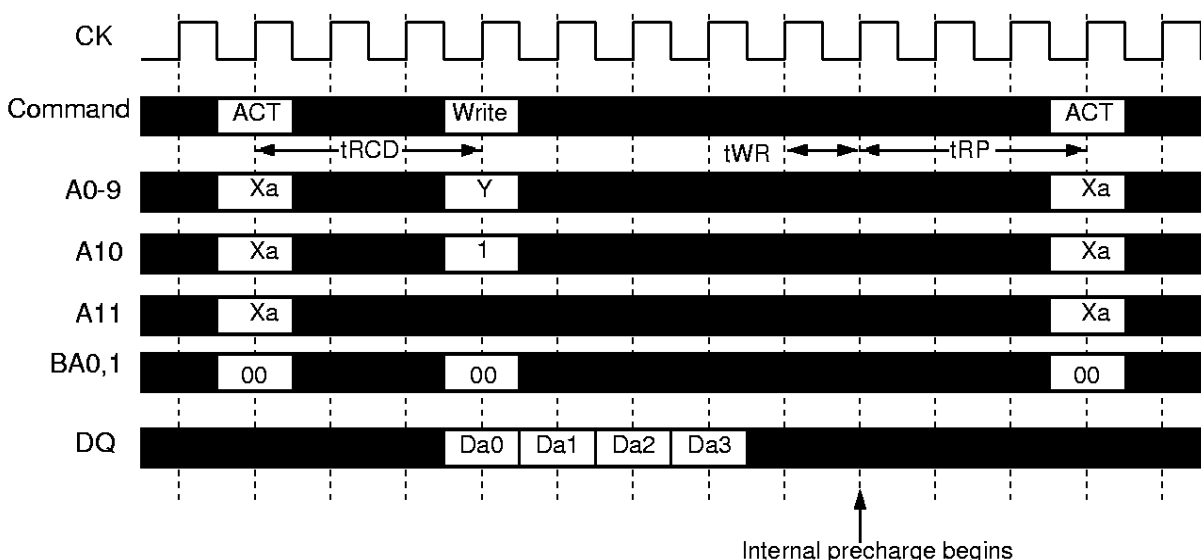

# MH8S64PHC -7,-8,-10

536870912-BIT (8388608 - WORD BY 64-BIT) Synchronous DRAM

## [ BURST WRITE ]

A burst write operation is enabled by setting A9=0 at MRS. A burst write starts in the same cycle as a write command set. (The latency of data input is 0.) The burst length can be set to 1, 2, 4, 8, and full-page, like burst read operations.

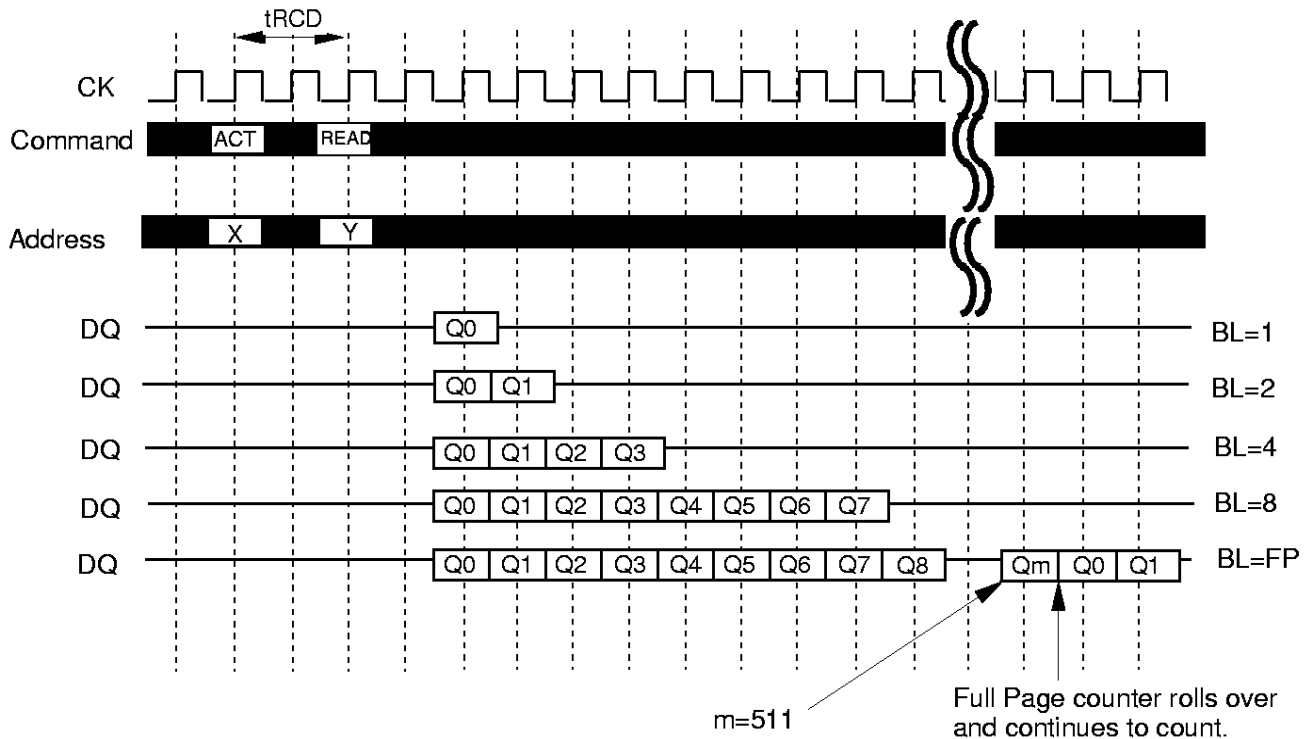

## [ SINGLE WRITE ]

A single write operation is enabled by setting A9=1 at MRS. In a single write operation, data is written only to the column address specified by the write command set cycle without regard to the burst length setting. (The latency of data input is 0.)

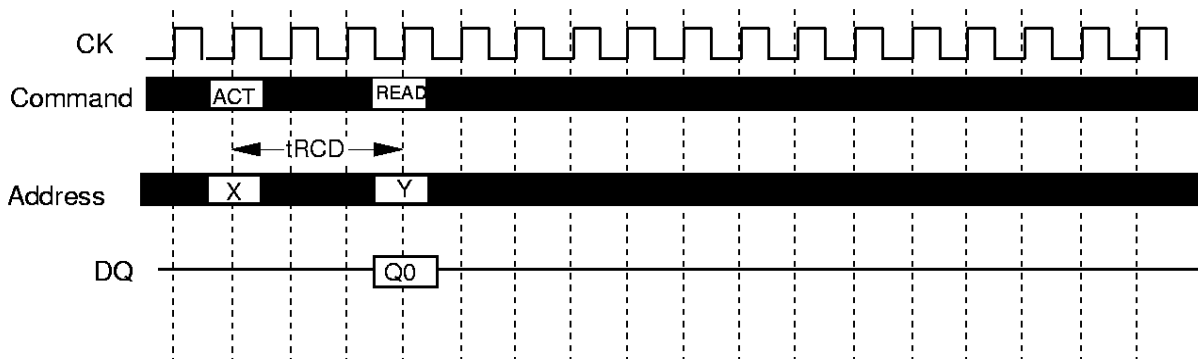

# MH8S64PHC -7,-8,-10

536870912-BIT (8388608 - WORD BY 64-BIT) Synchronous DRAM

## BURST INTERRUPTION

### [ Read Interrupted by Read ]

Burst read option can be interrupted by new read of any bank. Random column access is allowed. READ to READ interval is minimum 1 CK

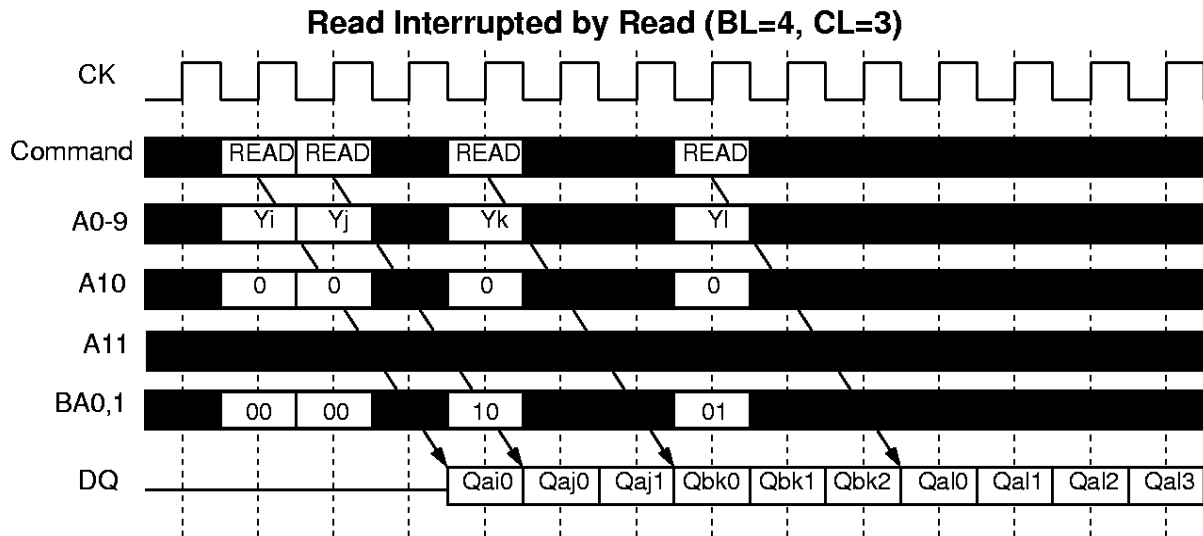

### [ Read Interrupted by Write ]

Burst read operation can be interrupted by write of the same or the other bank. Random column access is allowed. In this case, the DQ should be controlled adequately by using the DQMB0-7 to prevent the bus contention. The output is disabled automatically 1 cycle after WRITE assertion.

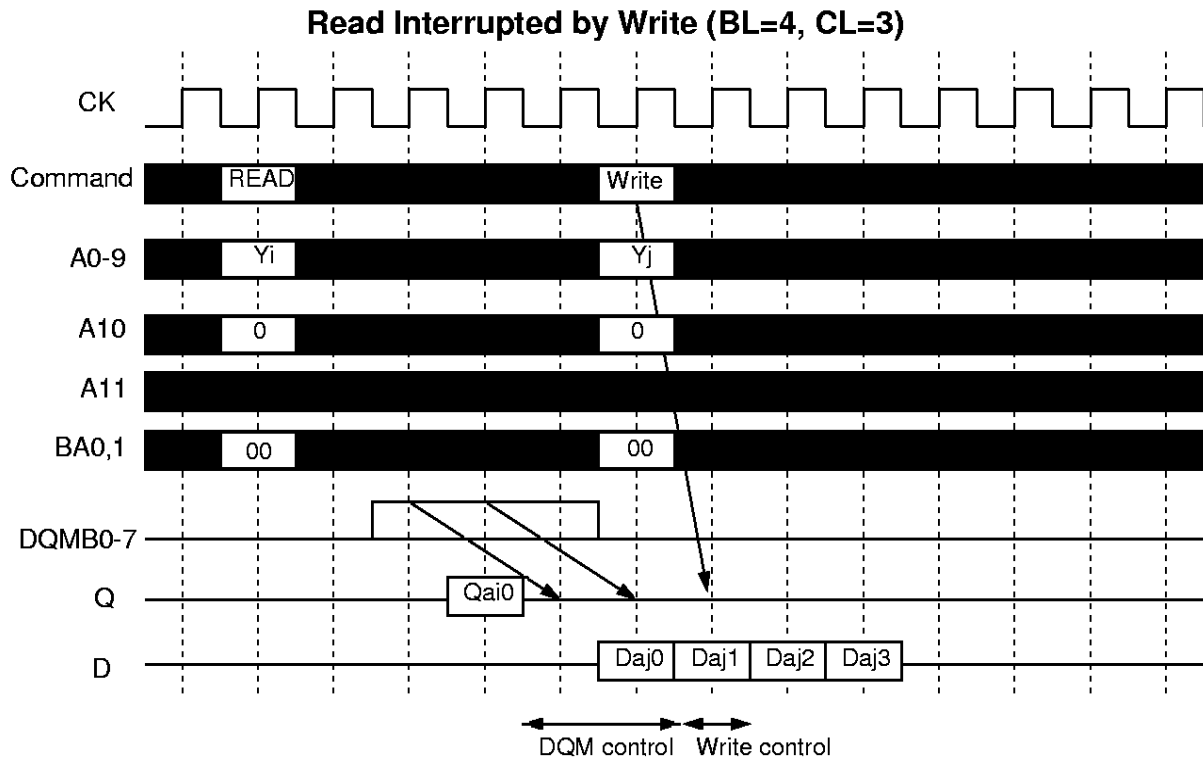

# MH8S64PHC -7,-8,-10

536870912-BIT (8388608 - WORD BY 64-BIT) Synchronous DRAM

## [ Read Interrupted by Precharge ]

Burst read operation can be interrupted by precharge of the same or the other bank. Read to PRE interval is minimum 1 CK. A PRE command output disable latency is equivalent to the /CAS Latency. As a result, READ to PRE interval determines valid data length to be output. The figure below shows examples of BL=4.

Read Interrupted by Precharge (BL=4)

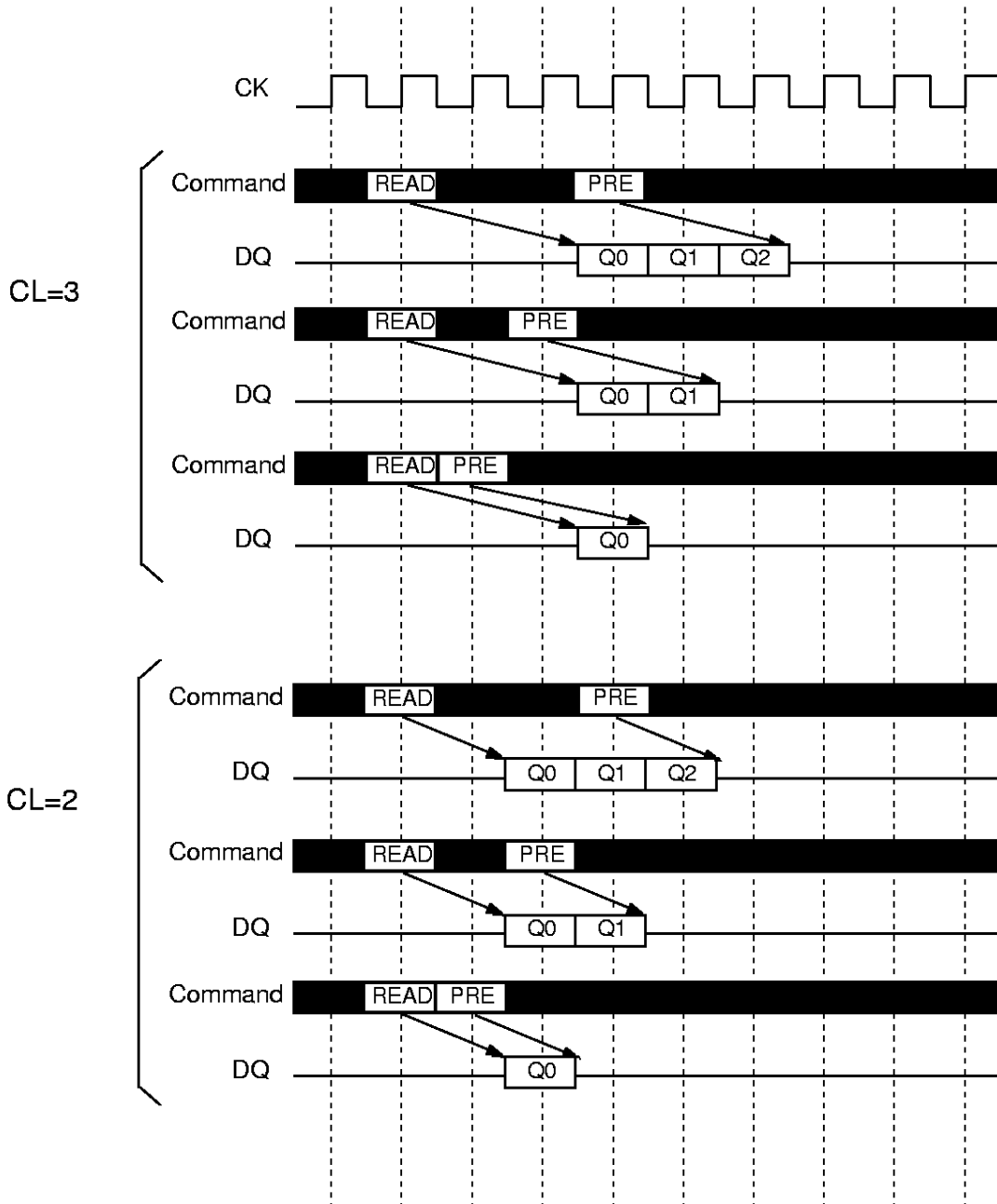

# MH8S64PHC -7,-8,-10

536870912-BIT (8388608 - WORD BY 64-BIT) Synchronous DRAM

## [ Read Interrupted by Burst Terminate ]

Similarly to the precharge, burst terminate command, TBST, can interrupt burst read operation and disable the data output. READ to TBST interval is minimum of 1 CK. TBST is mainly used to interrupt FP bursts. The figure below show examples, of how the output data is terminated with TBST.

### Read Interrupted by Burst Terminate (BL=4)

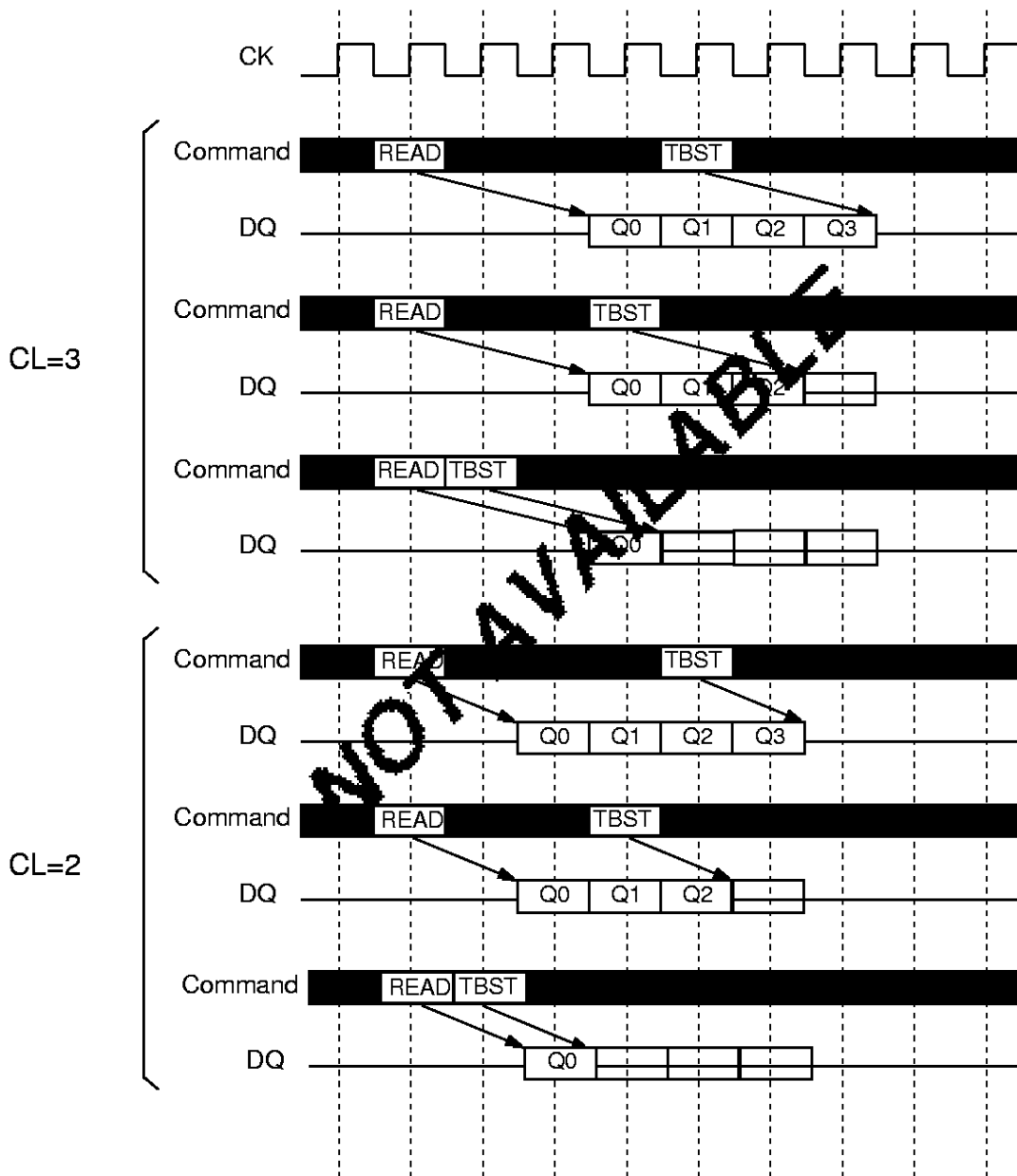

# MH8S64PHC -7,-8,-10

536870912-BIT (8388608 - WORD BY 64-BIT) Synchronous DRAM

## [ Write Interrupted by Write ]

Burst write operation can be interrupted by new write of the same or the other bank.  
Random column access is allowed. WRITE to WRITE interval is minimum 1 CK.

Write Interrupted by Write (BL=4)

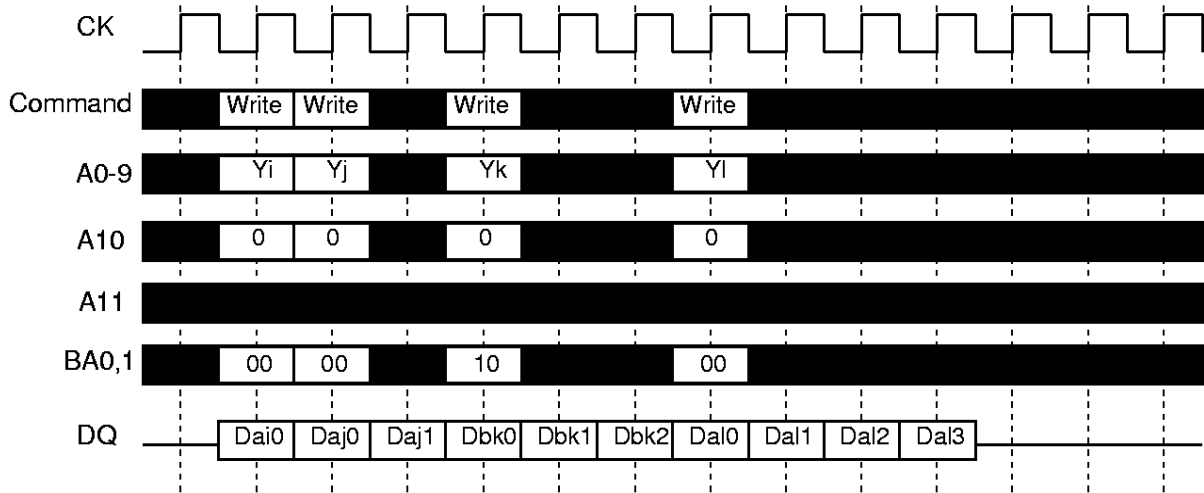

## [ Write Interrupted by Read ]

Burst write operation can be interrupted by read of the same or the other bank.  
Random column access is allowed. WRITE to READ interval is minimum 1 CK. The input data on DQ at the interrupting READ cycle is "don't care".

Write Interrupted by Read (BL=4, CL=3)

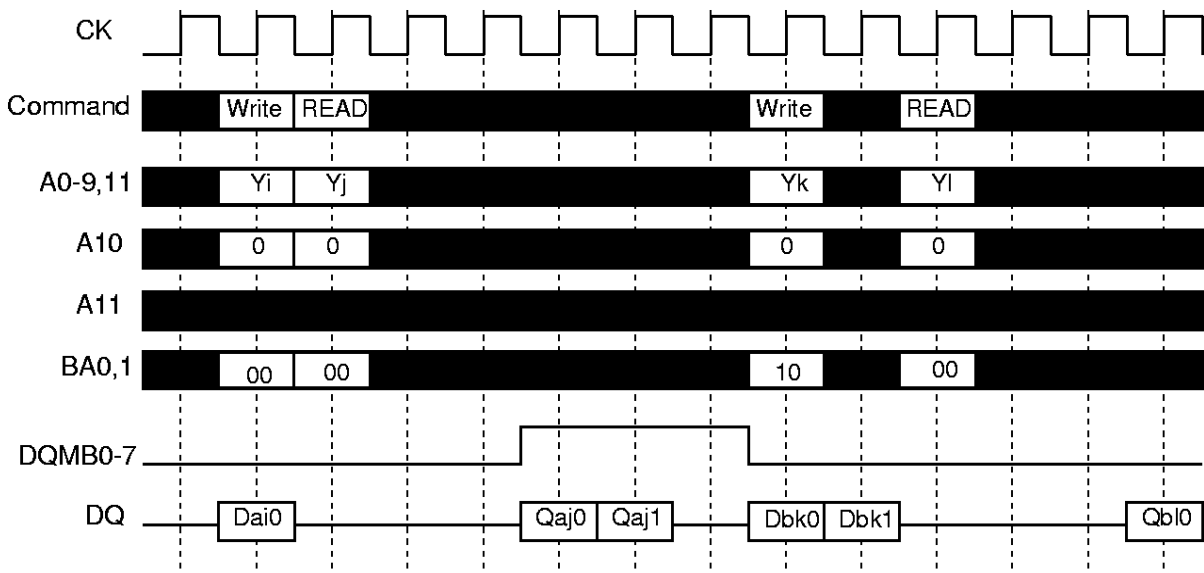

# MH8S64PHC -7,-8,-10

536870912-BIT (8388608 - WORD BY 64-BIT) Synchronous DRAM

## [ Write Interrupted by Precharge ]

Burst write operation can be interrupted by precharge of the same bank. Random column access is allowed. Because the write recovery time ( $t_{WR}$ ) is required from the last data to PRE command.

Write Interrupted by Precharge (BL=4)

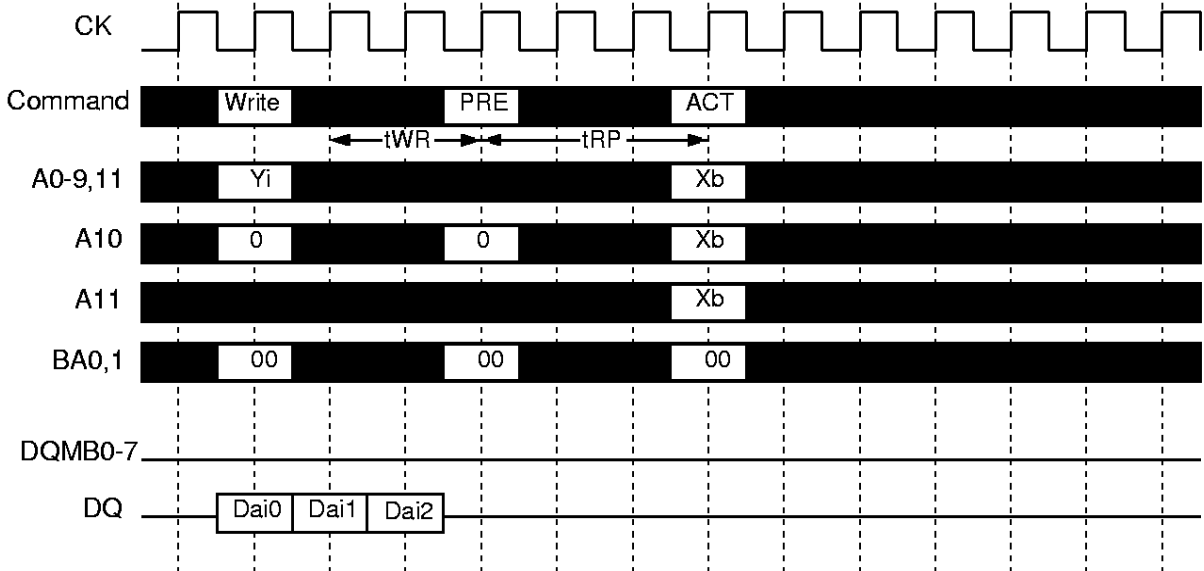

## [ Write Interrupted by Burst Terminate ]

A burst terminate command TBST can terminate burst write operation. In this case, the write recovery time is not required and the bank remains active (Please see the waveforms below). The WRITE to TBST minimum interval is 1CK.

Write Interrupted by Burst Terminate (BL=4)

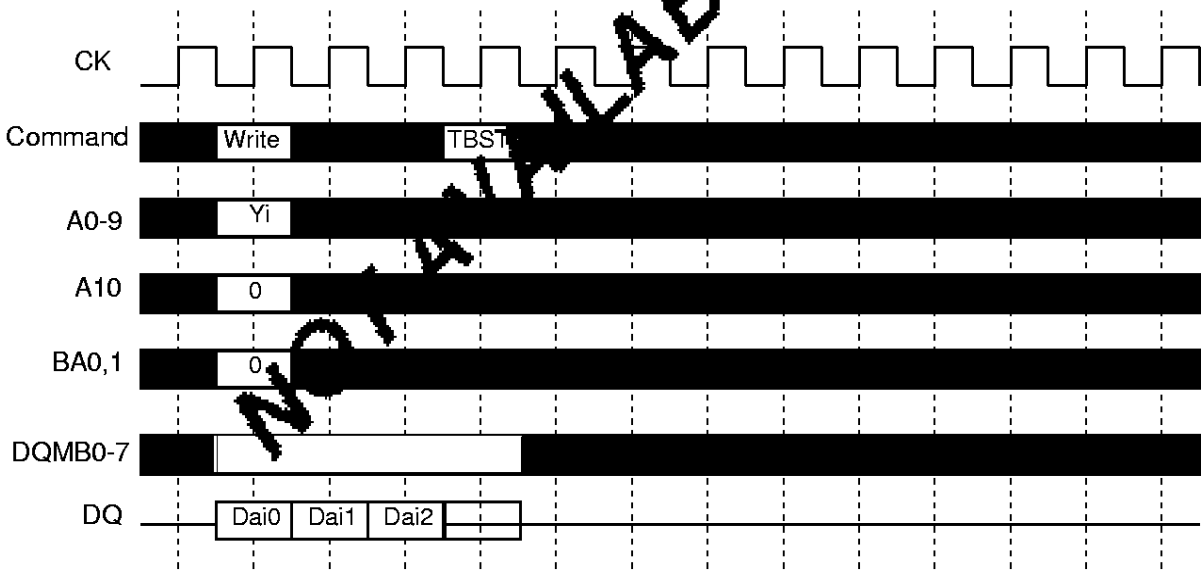

# MH8S64PHC -7,-8,-10

536870912-BIT (8388608 - WORD BY 64-BIT) Synchronous DRAM

## AUTO REFRESH

Single cycle of auto-refresh is initiated with a REFA(/CS=/RAS=/CAS=L, /WE=/CKE=H) command. The refresh address is generated internally. 4096 REFA cycles within 64ms refresh 128Mbit memory cells. The auto-refresh is performed on 4bank concurrently. Before performing an auto-refresh, all banks must be in the idle state. Auto-refresh to Auto-refresh interval is minimum tRC. Any command must not be supplied to the device before tRC from the REFA command.

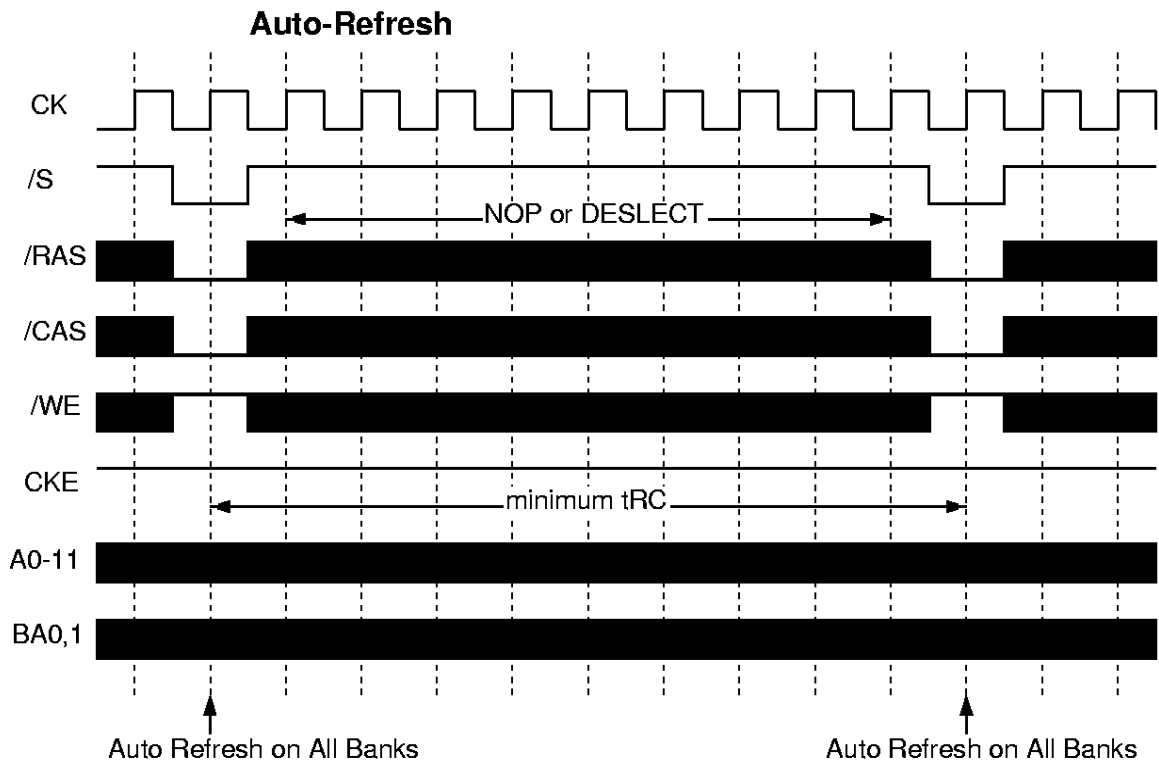

# MH8S64PHC -7,-8,-10

536870912-BIT (8388608 - WORD BY 64-BIT) Synchronous DRAM

## SELF REFRESH

Self-refresh mode is entered by issuing a REFS command ( $/CS=/RAS=/CAS=L$ ,  $/WE=H$ ,  $CKE=L$ ). Once the self-refresh is initiated, it is maintained as long as  $CKE$  is kept low. During the self-refresh mode,  $CKE$  is asynchronous and the only enabled input, all other inputs including  $CK$  are disabled and ignored, so that power consumption due to synchronous inputs is saved. To exit the self-refresh, supplying stable  $CK$  inputs, asserting  $DESEL$  or  $NOP$  command and then asserting  $CKE(REFSX)$  for longer than  $tSRX$ . After  $tRC$  from  $REFSX$  all banks are in the idle state and a new command can be issued after  $tRC$ , but  $DESEL$  or  $NOP$  commands must be asserted till then.

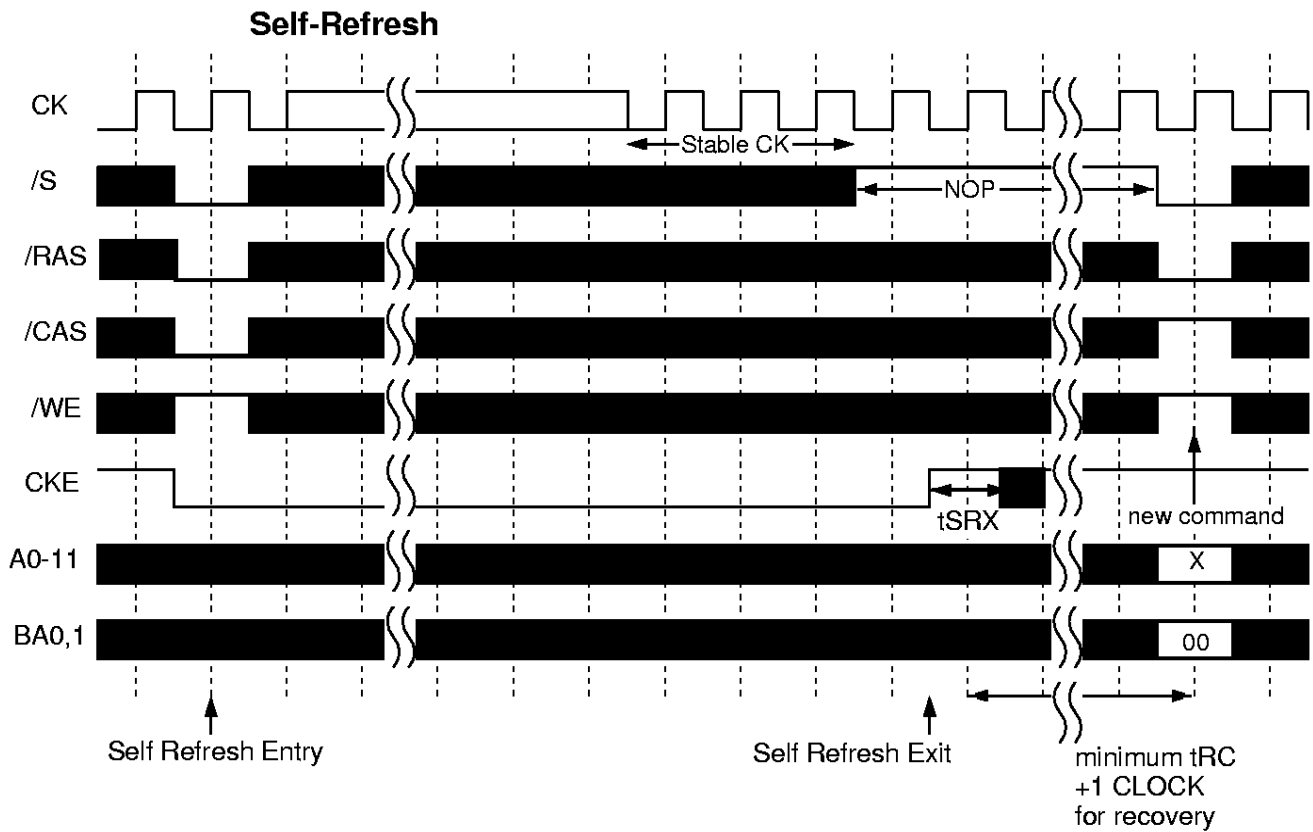

# MH8S64PHC -7,-8,-10

536870912-BIT (8388608 - WORD BY 64-BIT) Synchronous DRAM

## CLK SUSPEND

CKE controls the internal CLK at the following cycle. Figure below shows how CKE works. By negating CKE, the next internal CLK is suspended. The purpose of CLK suspend is power down, output suspend or input suspend. CKE is a synchronous input except during the self-refresh mode. CLK suspend can be performed either when the banks are active or idle, A command at the following cycle is ignored.

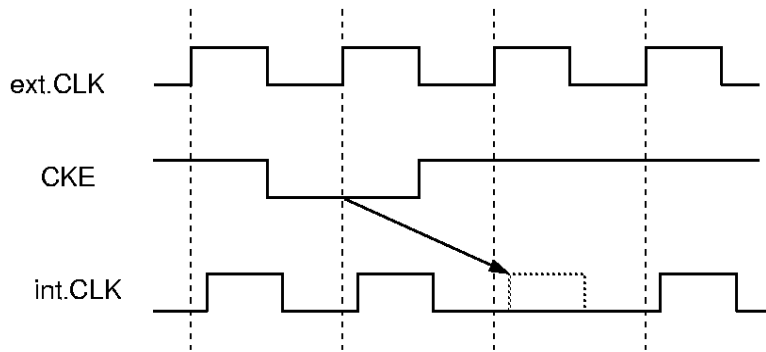

### Power Down by CKE

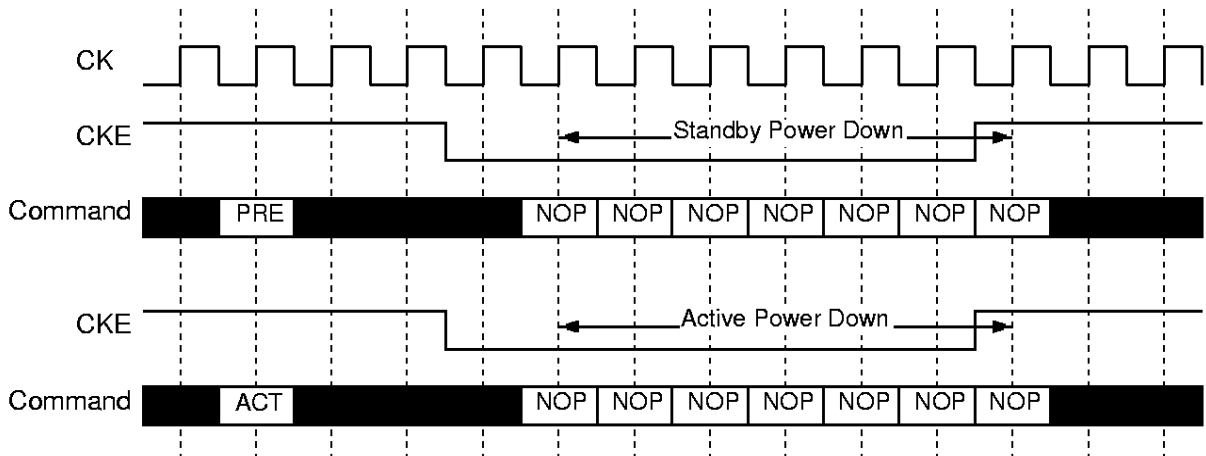

### DQ Suspend by CKE

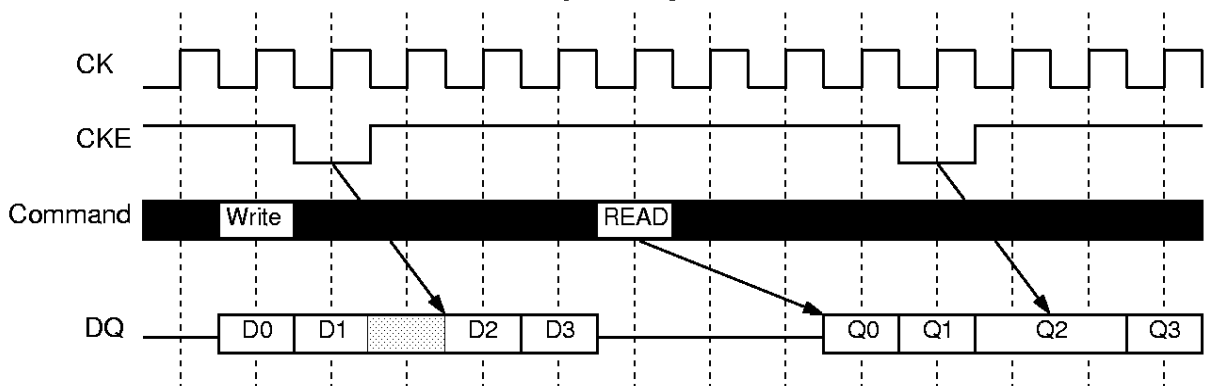

# MH8S64PHC -7,-8,-10

536870912-BIT (8388608 - WORD BY 64-BIT) Synchronous DRAM

## DQM CONTROL

DQMB0-7 is a dual function signal defined as the data mask for writes and the output disable for reads. During writes, DQMB0-7 masks input data word by word. DQMB0-7 to write mask latency is 0.

During reads, DQMB0-7 forces output to Hi-Z word by word. DQMB0-7 to output Hi-Z latency is 2.

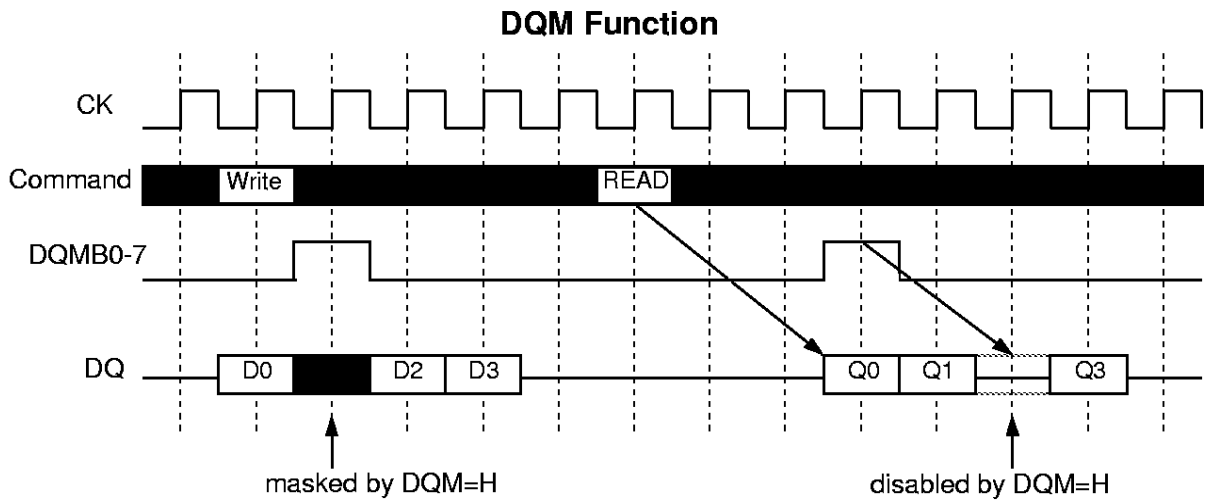

**MH8S64PHC -7,-8,-10**

536870912-BIT (8388608 - WORD BY 64-BIT) Synchronous DRAM

**ABSOLUTE MAXIMUM RATINGS**

Symbol	Parameter	Condition	Ratings	Unit
Vdd	Supply Voltage	with respect to Vss	-0.5 ~ 4.6	V
VI	Input Voltage	with respect to Vss	-0.5 ~ 4.6	V
VO	Output Voltage	with respect to Vss	-0.5 ~ 4.6	V
IO	Output Current		50	mA
Pd	Power Dissipation	Ta=25°C	4	W
Topr	Operating Temperature		0 ~ 70	°C
Tstg	Storage Temperature		-40 ~ 100	°C

**RECOMMENDED OPERATING CONDITION**

(Ta=0 ~ 70°C, unless otherwise noted)

Symbol	Parameter	Limits			Unit
		Min.	Typ.	Max.	
Vdd	Supply Voltage	3.0	3.3	3.6	V
Vss	Supply Voltage	0	0	0	V
VIH	High-Level Input Voltage all inputs	2.0		Vdd+0.3	V
VIL	Low-Level Input Voltage all inputs	-0.3		0.8	V

Note:\* VIH (max) = 5.5V for pulse width less than 10ns.

VIL (min) = -1.0V for pulse width less than 10ns.

**CAPACITANCE**

(Ta=0 ~ 70°C, Vdd = 3.3 ± 0.3V, Vss = 0V, unless otherwise noted)

Symbol	Parameter	Test Condition	Limits(max.)	Unit
CI(A)	Input Capacitance, address pin	VI = Vss f=1MHz Vi=25mVrms	37	pF
CI(C)	Input Capacitance, /RAS,/CAS,/WE		37	pF
CI(K)	Input Capacitance, CK pin		45	pF
CI(S)	Input Capacitance, /CS pin		37	pF
CI(E)	Input Capacitance, CKE pin		37	pF
CI(M)	Input Capacitance, DQM pin		15	pF
CI/O	Input Capacitance, I/O pin		15	pF

# MH8S64PHC -7,-8,-10

536870912-BIT (8388608 - WORD BY 64-BIT)SynchronousDRAM

## AVERAGE SUPPLY CURRENT from Vdd

(Ta=0 ~70°C, Vdd = 3.3 ± 0.3V, Vss = 0V, unless otherwise noted)

Parameter	Symbol	Test Condition	Limits (max)		Unit	Note
			-7, -8	-10		
operating current one bank active (discrete)	Icc1	tRC=min.tCLK=min, BL=1, CL=3	540	420	mA	*1
precharge standby current in non power-down mode /CS>Vcc-0.2V	Icc2N	tCLK=15ns, CKE = H, VIH > Vcc - 0.2V, VIL < 0.2V	100	100	mA	*1
	Icc2NS	CLK=L & CKE=H, VIH > Vcc - 0.2V, VIL < 0.2V all input signals are fixed.	60	60	mA	*1
precharge standby current in power-down mode /CS>Vcc-0.2V	Icc2P	tCLK = 15ns, CKE = L	8	8	mA	*1
	Icc2PS	CLK = L, CKE = L	4	4	mA	*1
active standby current	Icc3N	CKE=H, tCLK=15ns	160	160	mA	*1
	Icc3NS	CKE=H, CLK=L	140	140	mA	*1
burst current	Icc4	tCLK=min, BL=4, CL=3 Aall banks active	640	640	mA	*1
auto-refresh current	Icc5	tRC=min, tCLK=min	800	800	mA	*1
self-refresh current	Icc6	CKE <0.2V	8	8	mA	*1,2
			3.2	3.2	mA	

Note1:Icc(max) is specified at the output open condition.

Note2:Low Power version

## AC OPERATING CONDITIONS AND CHARACTERISTICS

(Ta=0 ~ 70°C, Vdd = 3.3 ± 0.3V, Vss = 0V, unless otherwise noted)

Symbol	Parameter	Test Condition	Limits		Unit
			Min.	Max.	
VOH(DC)	High-Level Output Voltage(DC)	IOH=-2mA	2.4		V
VOL(DC)	Low-Level Output Voltage(DC)	IOL=2mA		0.4	V
IOZ	Off-stare Output Current	Q floating VO=0 ~ Vdd	-10	10	µA
Ii	Input Current	VIH=0 ~ Vdd+0.3V	-40	40	µA

# MH8S64PHC -7,-8,-10

536870912-BIT (8388608 - WORD BY 64-BIT) Synchronous DRAM

## AC TIMING REQUIREMENTS (SDRAM Component)

(Ta=0 ~ 70°C, Vdd = 3.3 ± 0.3V, Vss = 0V, unless otherwise noted)

Input Pulse Levels: 0.8V to 2.0V

Input Timing Measurement Level: 1.4V

Symbol	Parameter	Limits						Unit	
		-7		-8		-10			
		Min.	Max.	Min.	Max.	Min.	Max.		
tCLK	CK cycle time	CL=2	10		13		15		ns
		CL=3	10		10		10		ns
tCH	CK High pulse width	3		3		4		ns	
tCL	CK Low pulse width	3		3		4		ns	
tT	Transition time of CK	1	10	1	10	1	10	ns	
tIS	Input Setup time(all inputs)	2		2		3		ns	
tIH	Input Hold time(all inputs)	1		1		1		ns	
tRC	Row cycle time	70		70		90		ns	
tRCD	Row to Column Delay	20		20		30		ns	
tRAS	Row Active time	50	100K	50	100K	60	100K	ns	
tRP	Row Precharge time	20		20		30		ns	
tWR	Write Recovery time	20		20		15		ns	
tRRD	Act to Act Deley time	20		20		20		ns	
tRSC	Mode Register Set Cycle time	20		20		20		ns	
tSRX	Self Refresh Exit time	10		10		10		ns	
tPDE	Power Down Exit time	10		10		10		ns	
tREF	Refresh Interval time		64		64		64	ms	

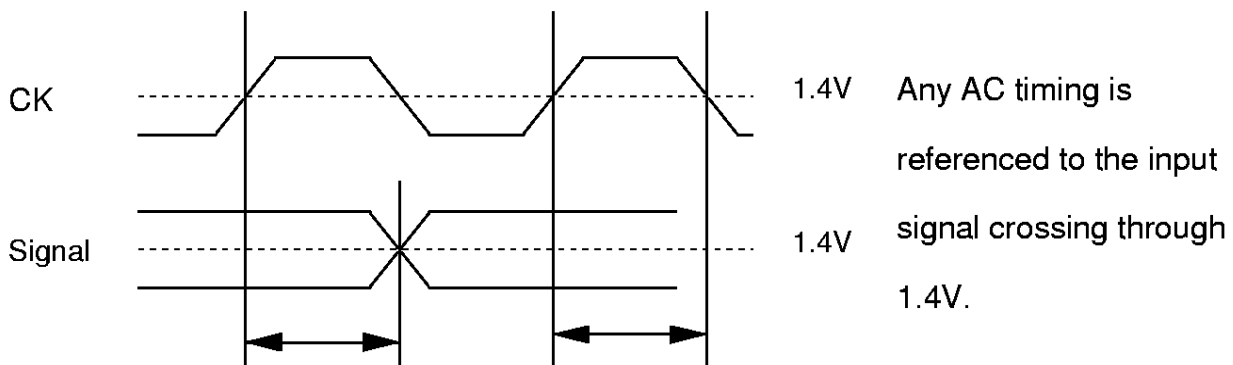

# MH8S64PHC -7,-8,-10

536870912-BIT (8388608 - WORD BY 64-BIT) Synchronous DRAM

## SWITCHING CHARACTERISTICS (SDRAM Component)

( $T_a=0 \sim 70^\circ\text{C}$ ,  $V_{dd} = 3.3 \pm 0.3\text{V}$ ,  $V_{ss} = 0\text{V}$ , unless otherwise note3)

Symbol	Parameter	Limits						Unit	
		-7		-8		-10			
		Min.	Max.	Min.	Max.	Min.	Max.		
tAC	Access time from CK	CL=2		6		7		8	ns
		CL=3		6		6		8	ns
tOH	Output Hold time from CK	3		3		3		ns	
tOLZ	Delay time, output low impedance from CK	0		0		0		ns	
tOHZ	Delay time, output high impedance from CK	3	6	3	6	3	8	ns	

Note:3 If  $t_r$ (clock rising time) is longer than 1ns,  $(t_r/2-0.5)\text{ns}$  should be added to parameter.

### Output Load Condition

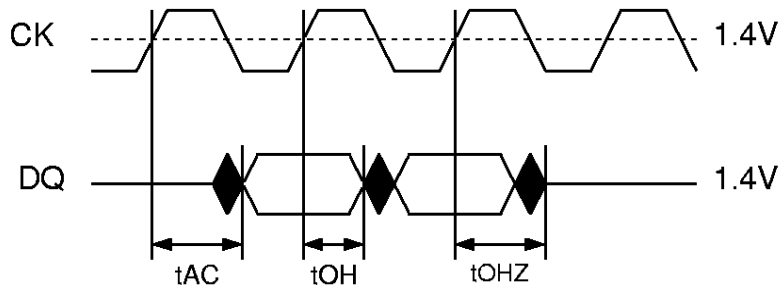
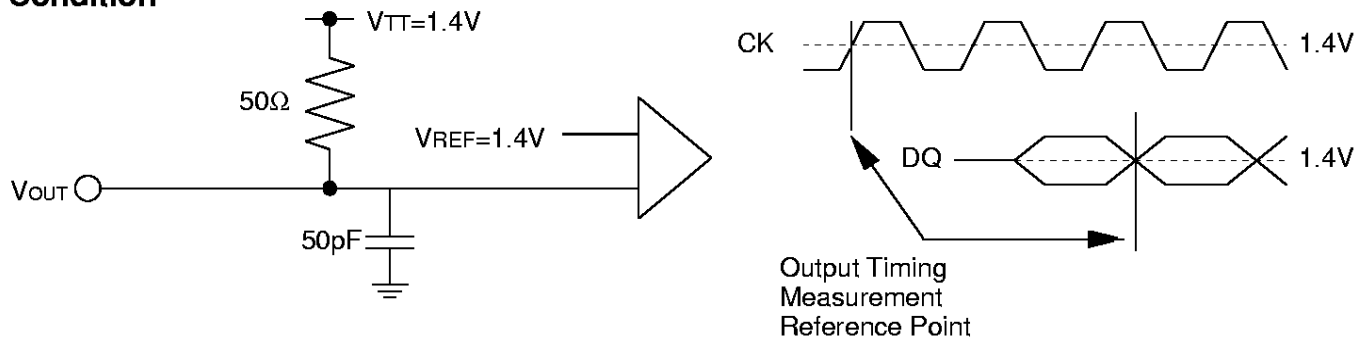

# MH8S64PHC -7,-8,-10

536870912-BIT (8388608 - WORD BY 64-BIT) Synchronous DRAM

## Burst Write (single bank) @BL=4

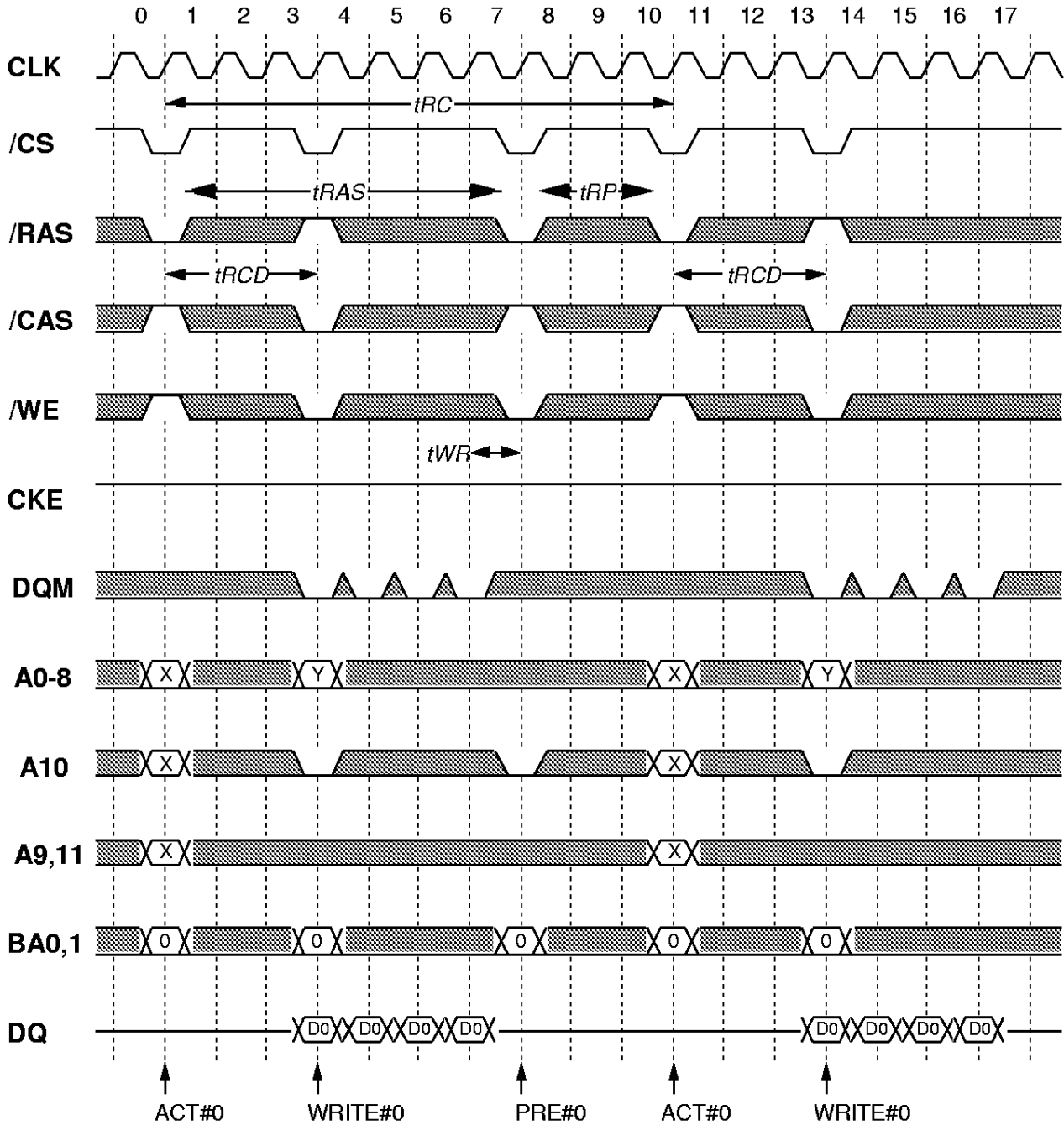

*Italic parameter* indicates minimum case

# MH8S64PHC -7,-8,-10

536870912-BIT (8388608 - WORD BY 64-BIT) Synchronous DRAM

## Burst Write (multi bank) @BL=4

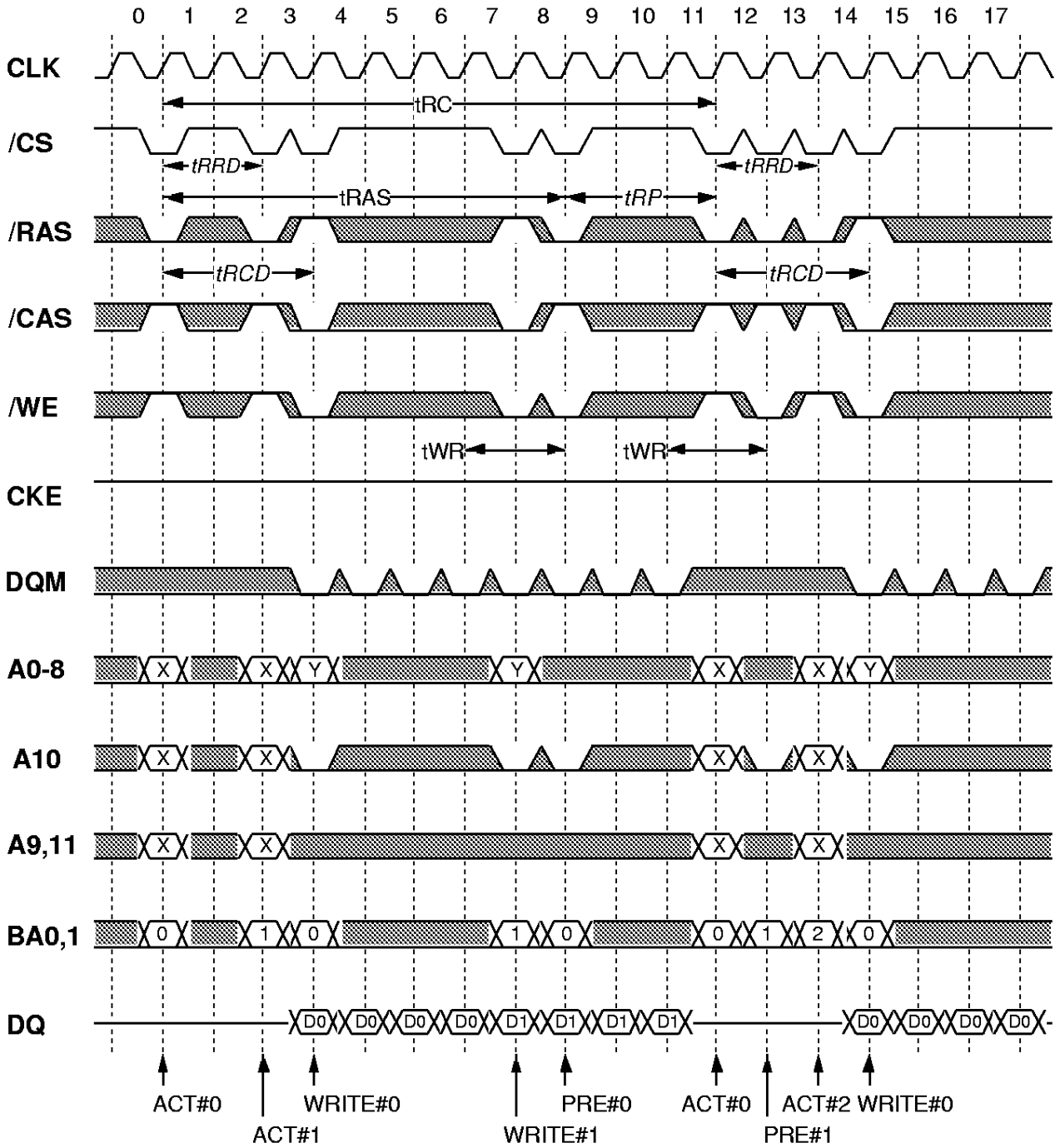

*Italic parameter* indicates minimum case

# MH8S64PHC -7,-8,-10

536870912-BIT (8388608 - WORD BY 64-BIT) Synchronous DRAM

## Burst Read (single bank) @BL=4 CL=3

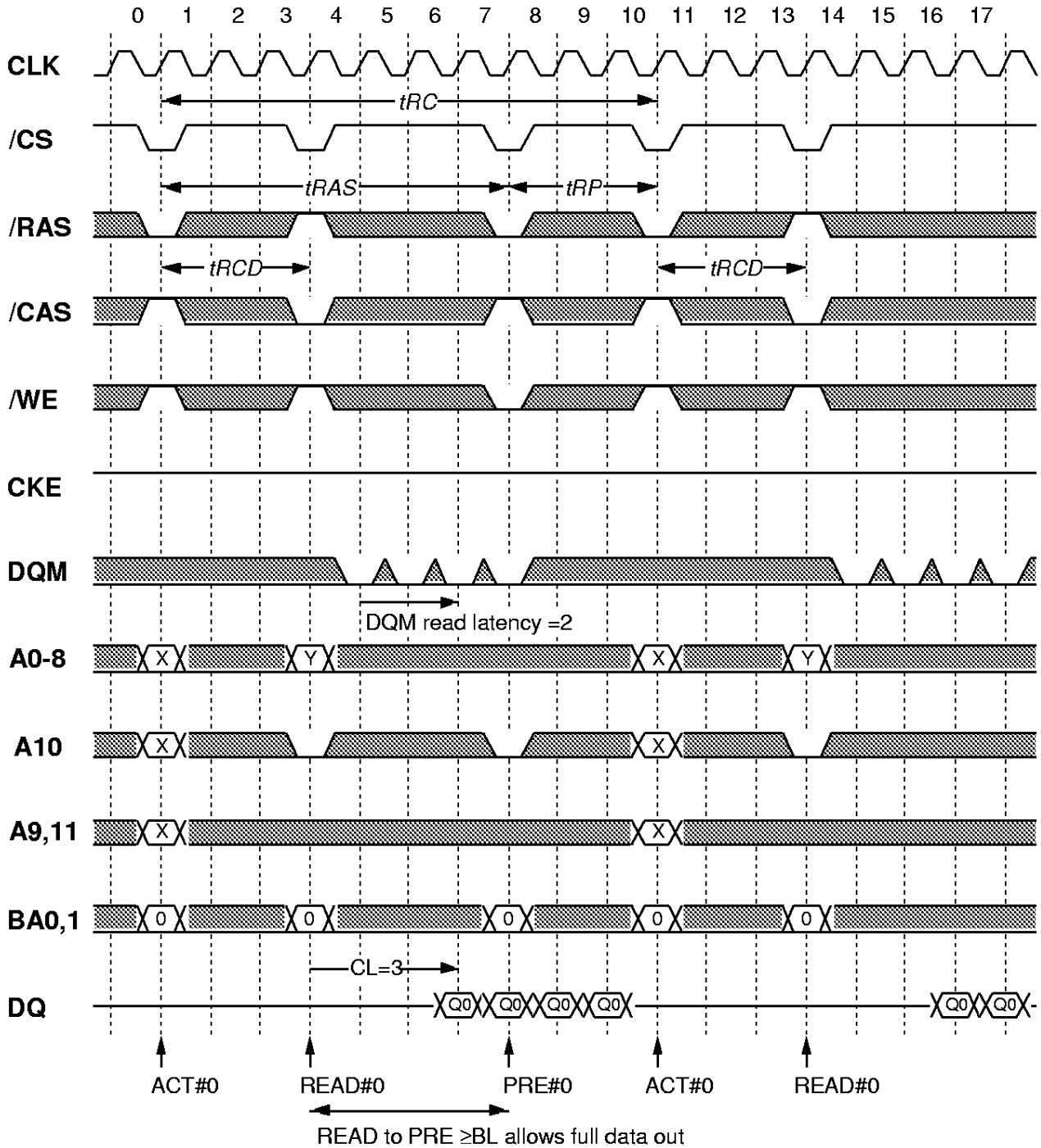

*Italic parameter* indicates minimum case

# MH8S64PHC -7,-8,-10

536870912-BIT (8388608 - WORD BY 64-BIT) Synchronous DRAM

## Burst Read (multiple bank) @BL=4 CL=3

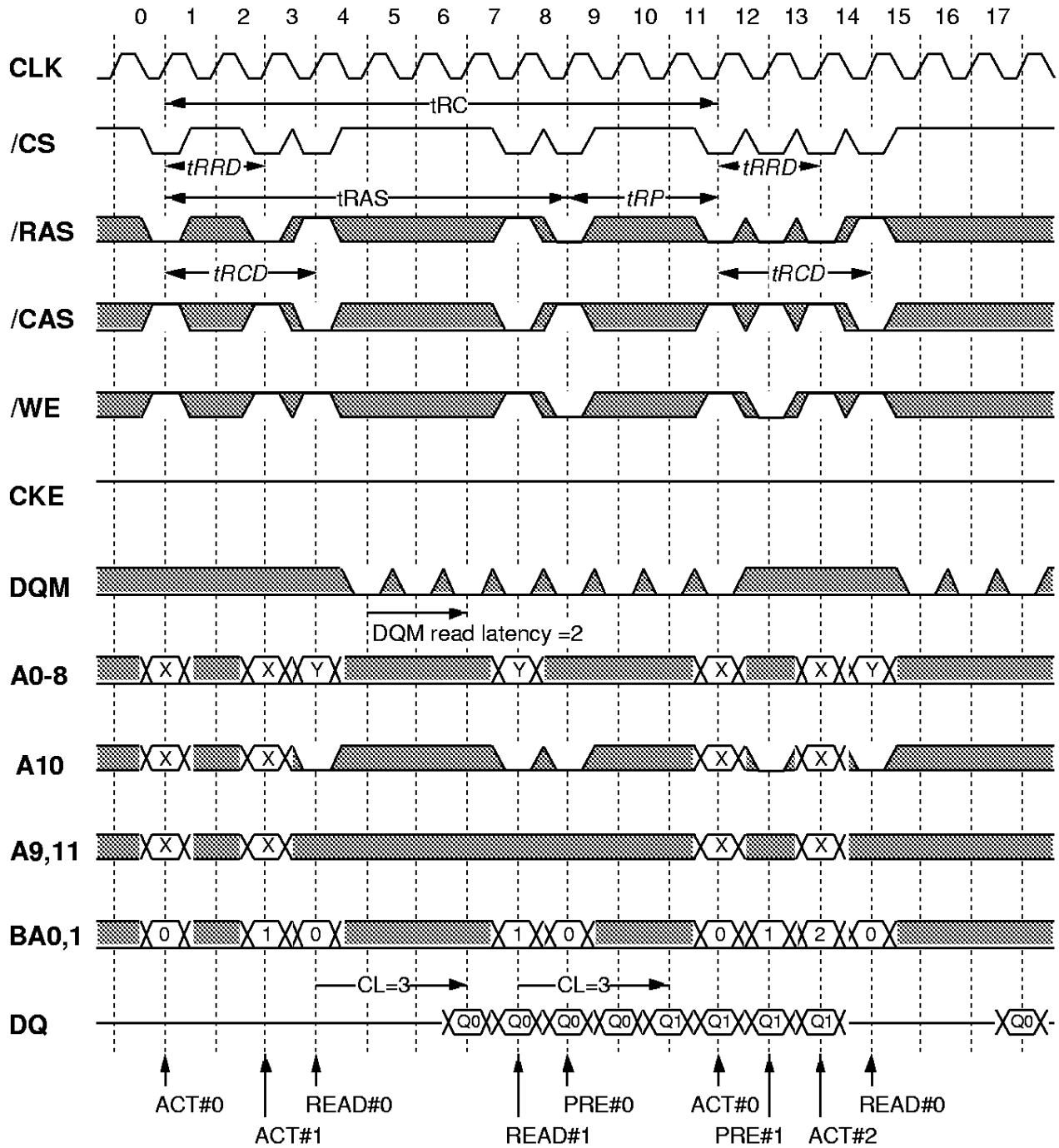

*Italic parameter* indicates minimum case

# MH8S64PHC -7,-8,-10

536870912-BIT (8388608 - WORD BY 64-BIT) Synchronous DRAM

## Burst Write (multi bank) with Auto-Precharge @BL=4

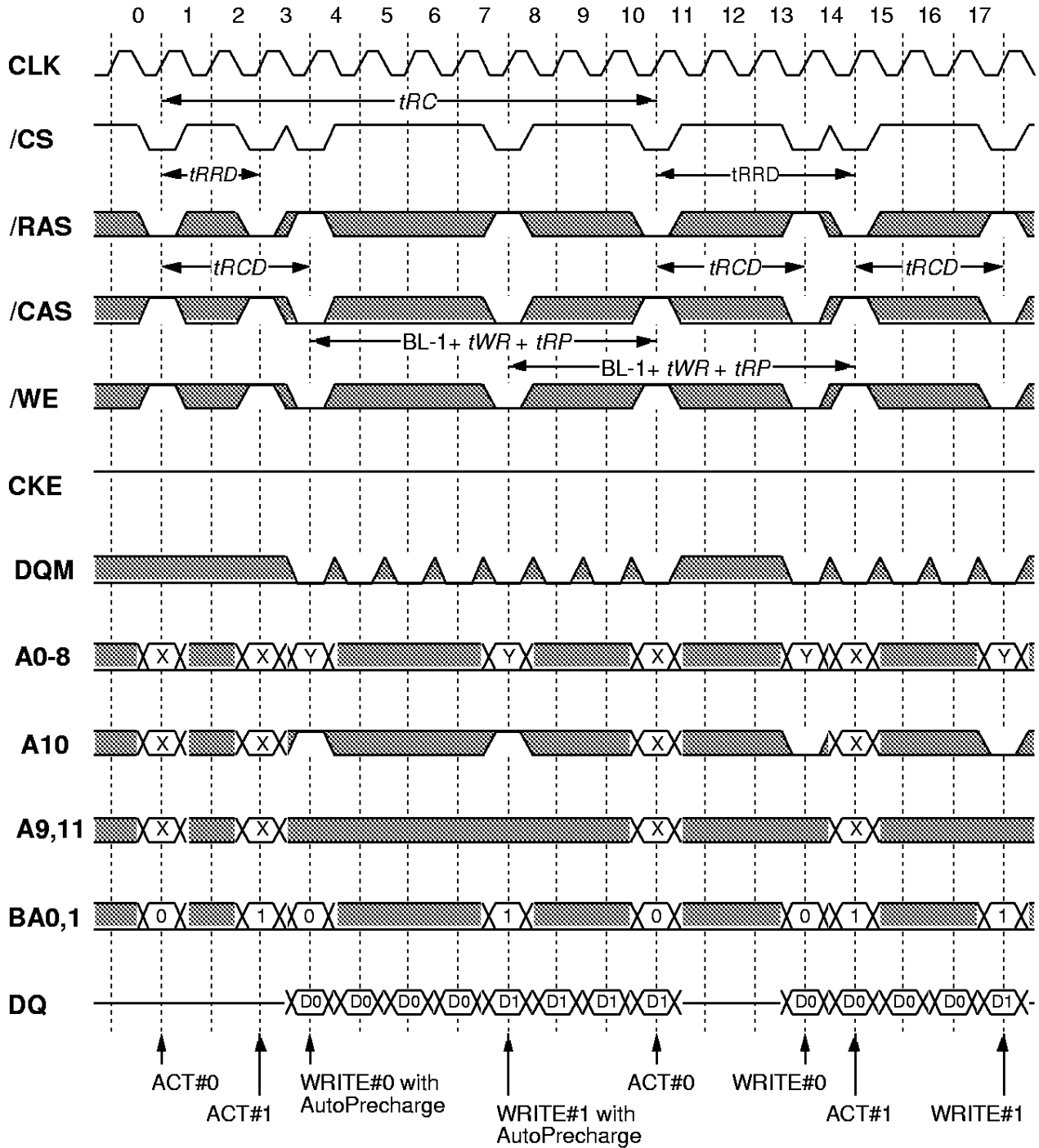

*Italic parameter* indicates minimum case



# MH8S64PHC -7,-8,-10

536870912-BIT (8388608 - WORD BY 64-BIT) Synchronous DRAM

## Page Mode Burst Write (multi bank) @BL=4

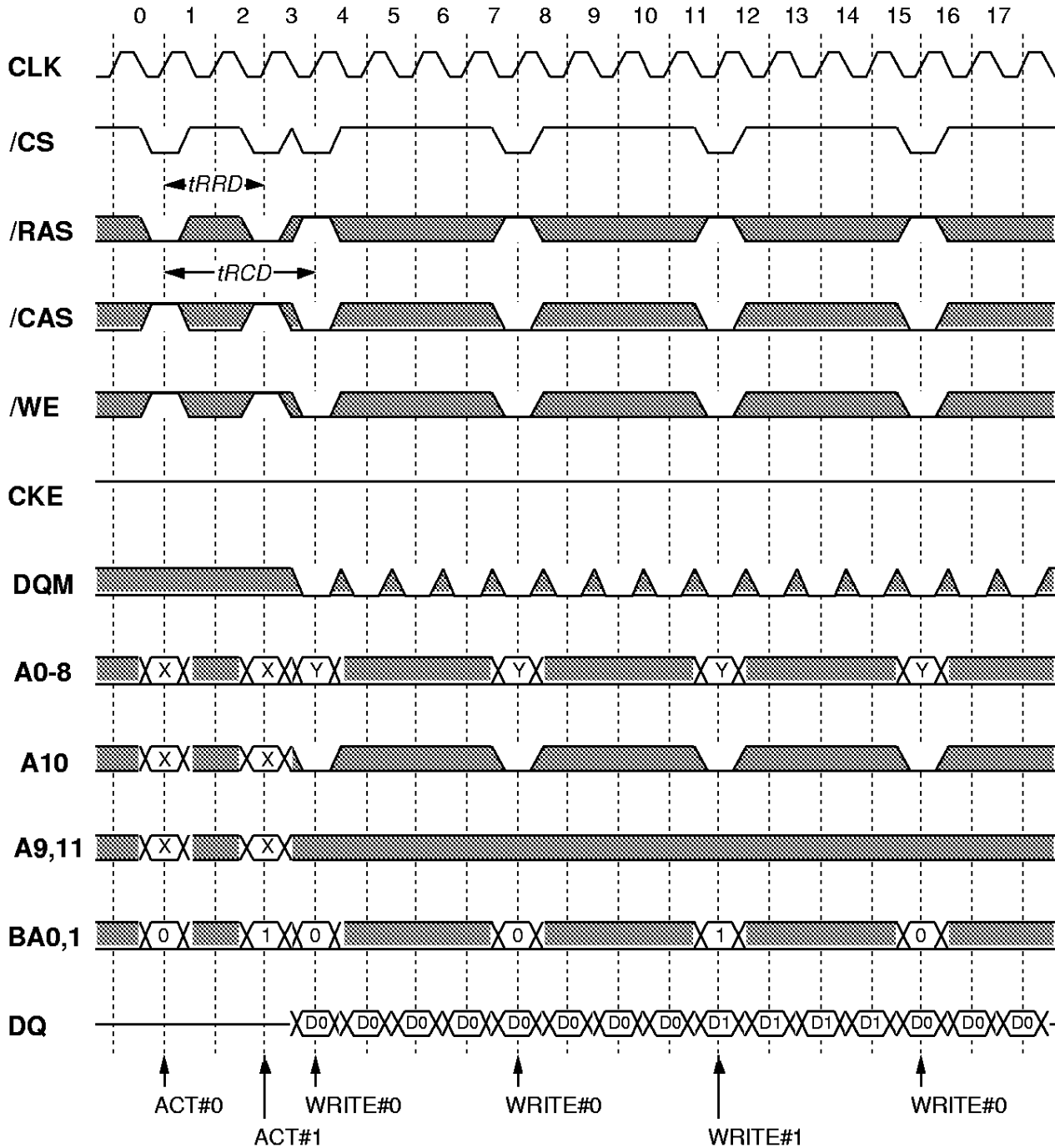

*Italic parameter* indicates minimum case

# MH8S64PHC -7,-8,-10

536870912-BIT (8388608 - WORD BY 64-BIT) Synchronous DRAM

## Page Mode Burst Read (multi bank) @BL=4 CL=3

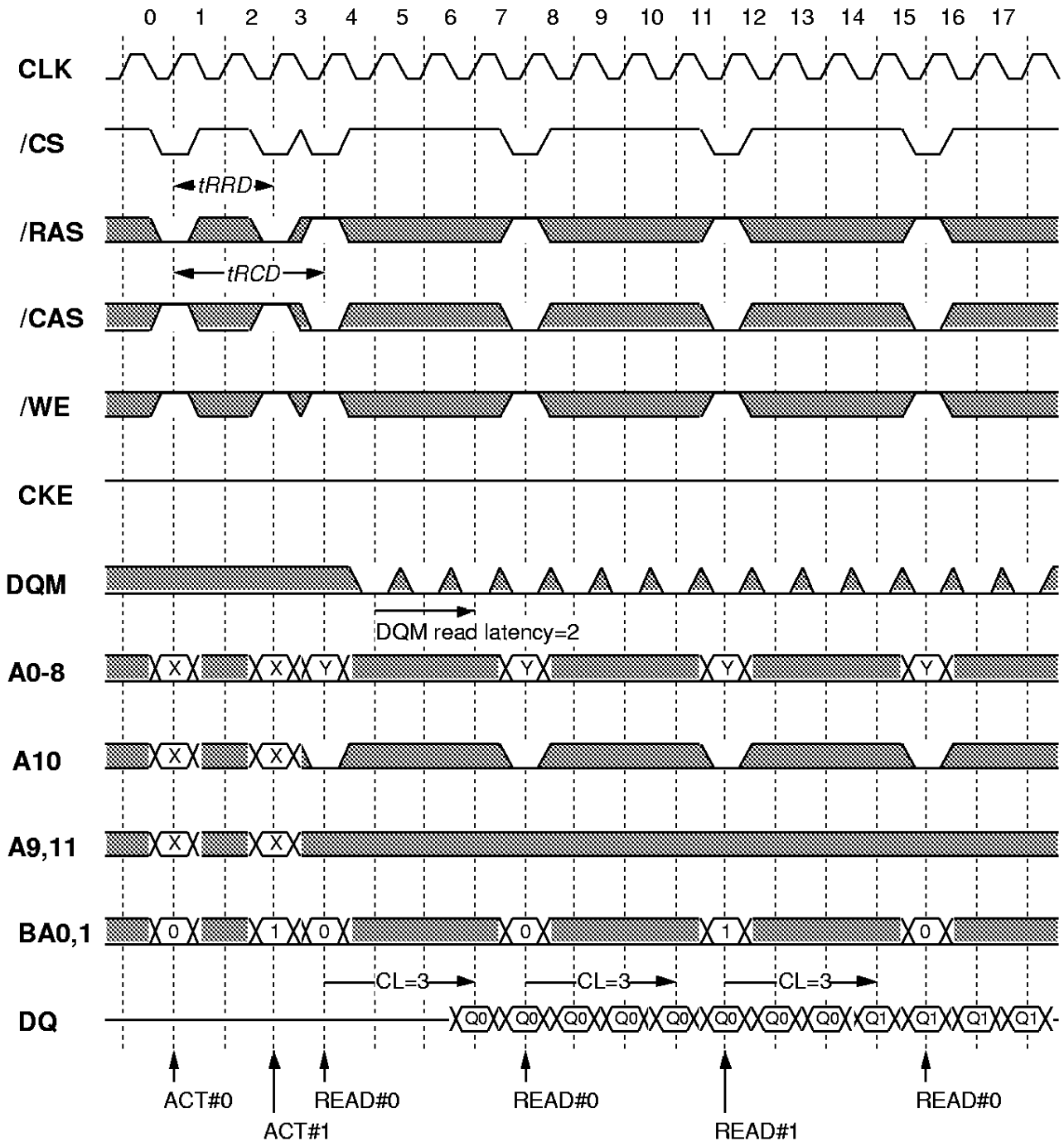

*Italic parameter* indicates minimum case

# MH8S64PHC -7,-8,-10

536870912-BIT (8388608 - WORD BY 64-BIT) Synchronous DRAM

## Write Interrupted by Write / Read @BL=4

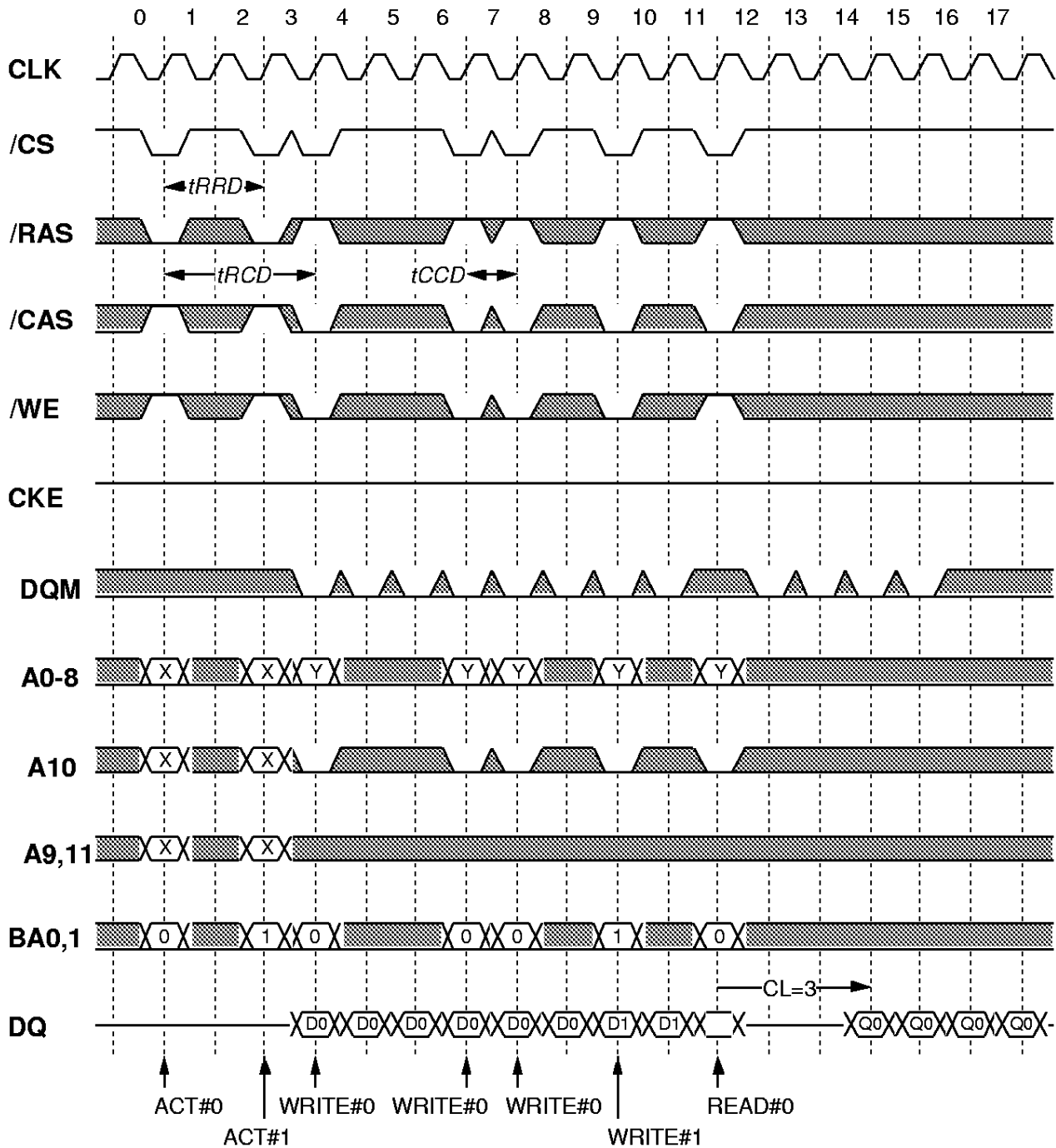

Burst Write can be interrupted by Write or Read of any active bank.

*Italic parameter* indicates minimum case

# MH8S64PHC -7,-8,-10

536870912-BIT (8388608 - WORD BY 64-BIT) Synchronous DRAM

## Read Interrupted by Read / Write @BL=4 CL=3

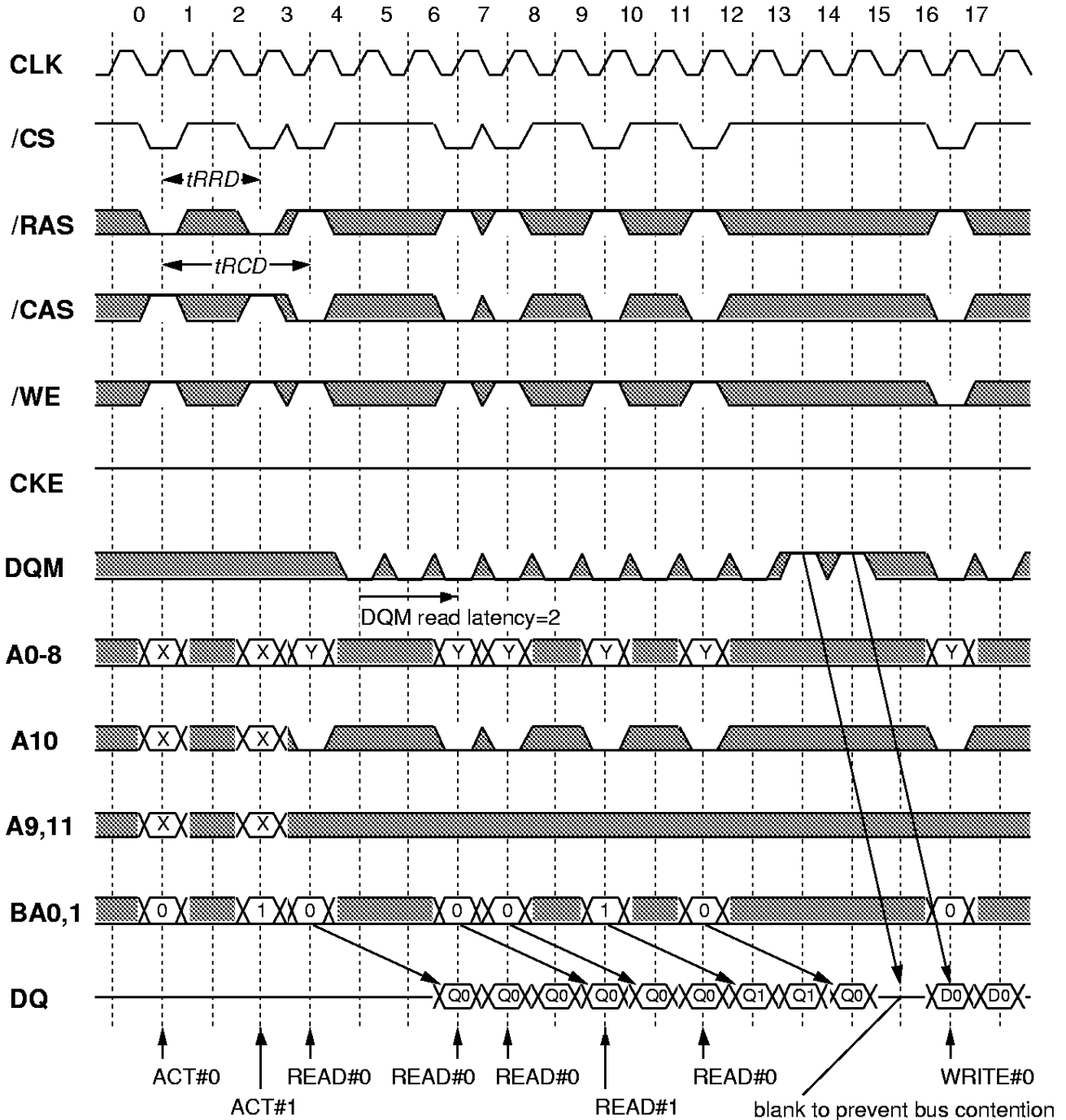

Burst Read can be interrupted by Read or Write of any active bank.

*Italic parameter* indicates minimum case

# MH8S64PHC -7,-8,-10

536870912-BIT (8388608 - WORD BY 64-BIT) Synchronous DRAM

## Write Interrupted by Precharge @BL=4

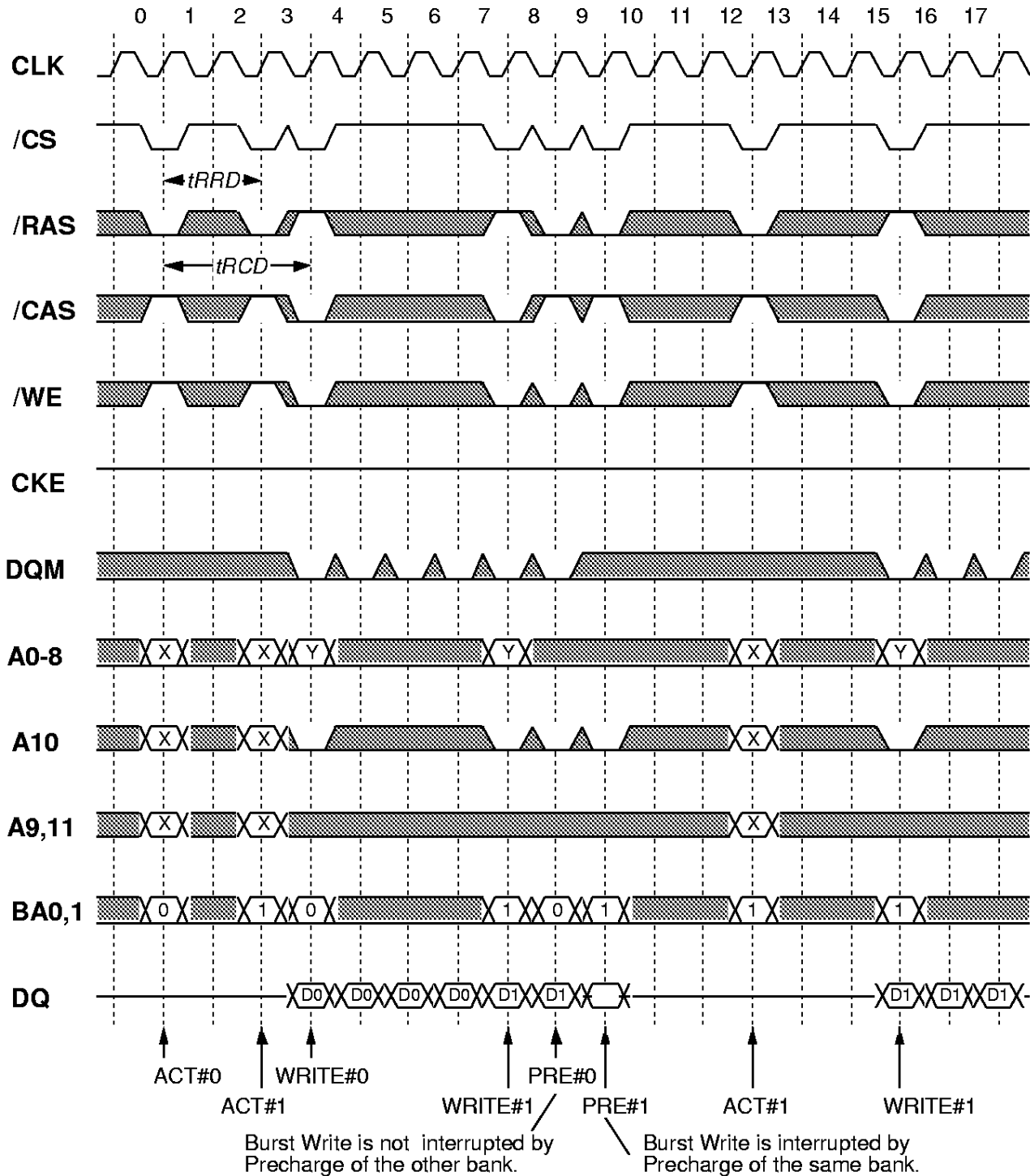

*Italic parameter* indicates minimum case

# MH8S64PHC -7,-8,-10

536870912-BIT (8388608 - WORD BY 64-BIT) Synchronous DRAM

## Read Interrupted by Precharge @BL=4 CL=3

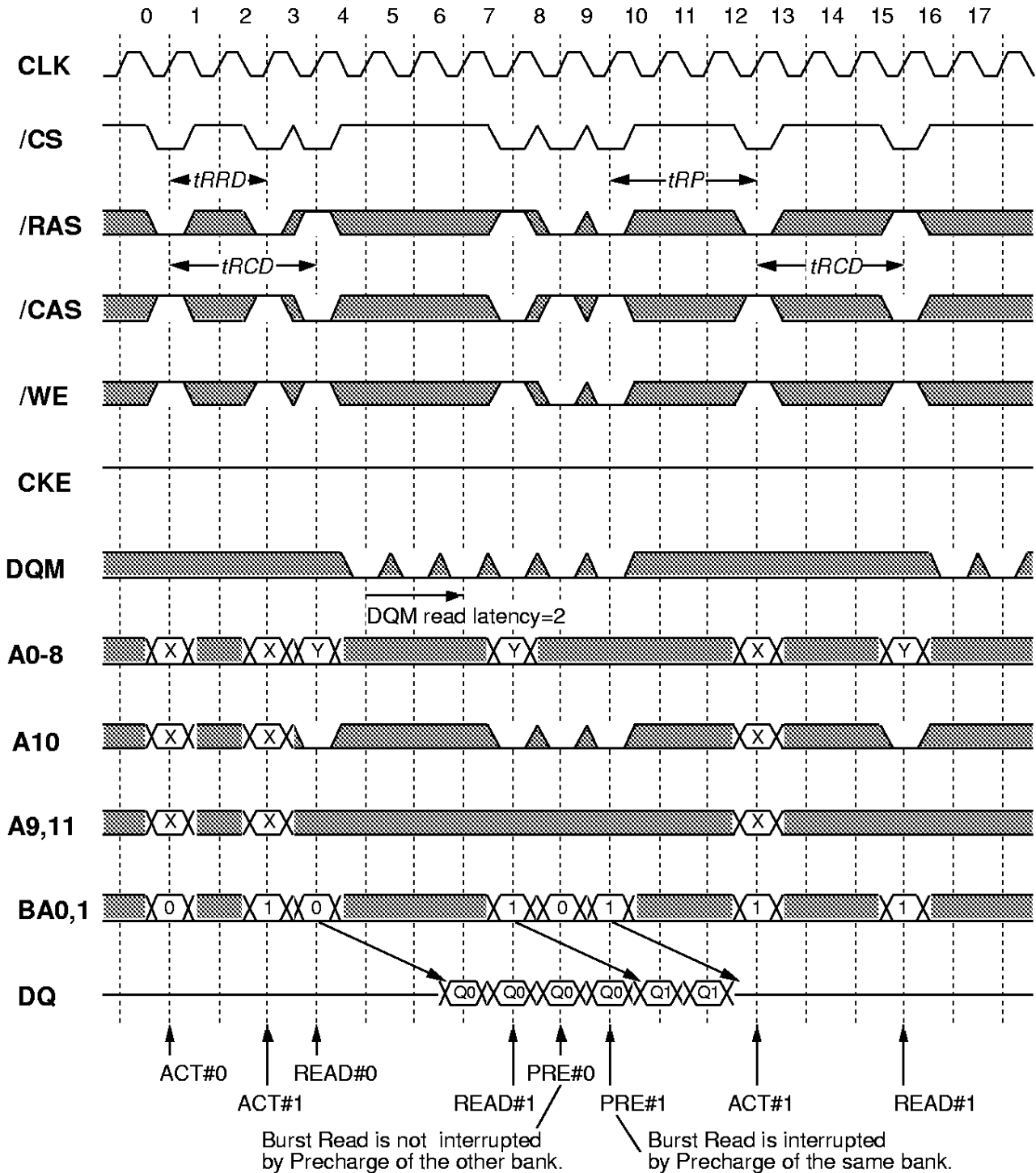

*Italic parameter* indicates minimum case

# MH8S64PHC -7,-8,-10

536870912-BIT (8388608 - WORD BY 64-BIT) Synchronous DRAM

## Mode Register Setting

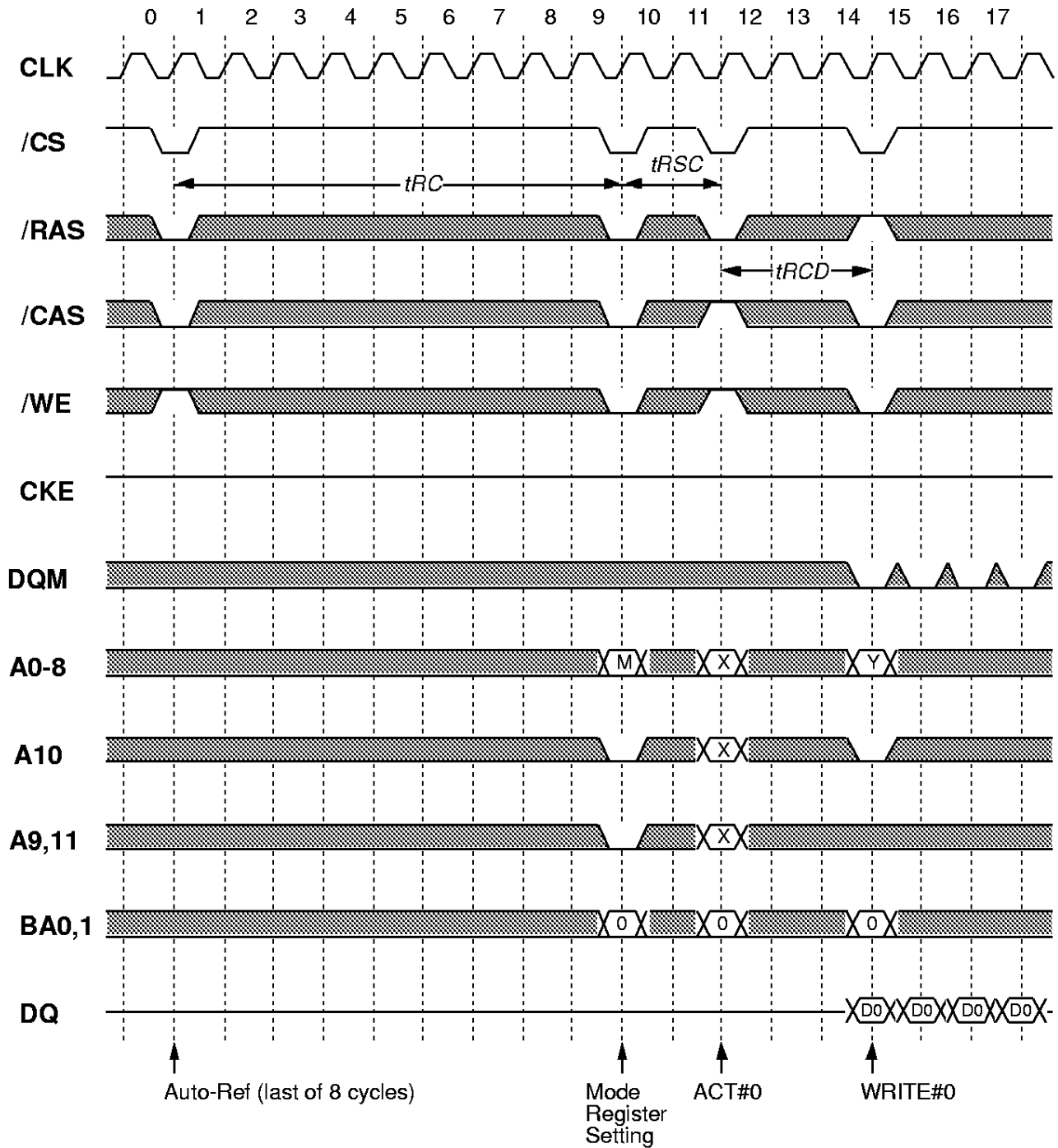

*Italic parameter* indicates minimum case

# MH8S64PHC -7,-8,-10

536870912-BIT (8388608 - WORD BY 64-BIT) Synchronous DRAM

## Auto-Refresh @BL=4

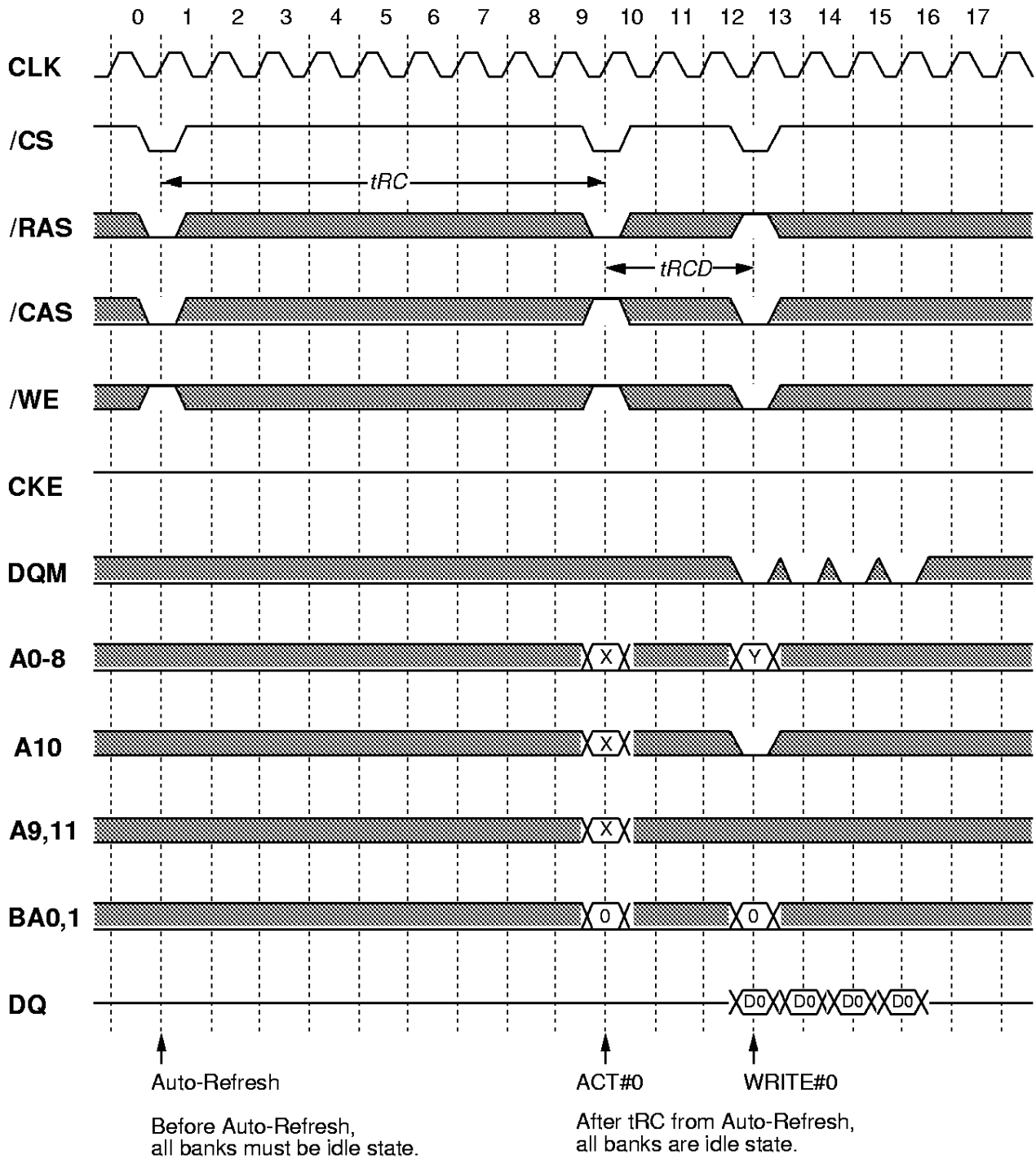

*Italic parameter* indicates minimum case

# MH8S64PHC -7,-8,-10

536870912-BIT (8388608 - WORD BY 64-BIT) Synchronous DRAM

## Self-Refresh

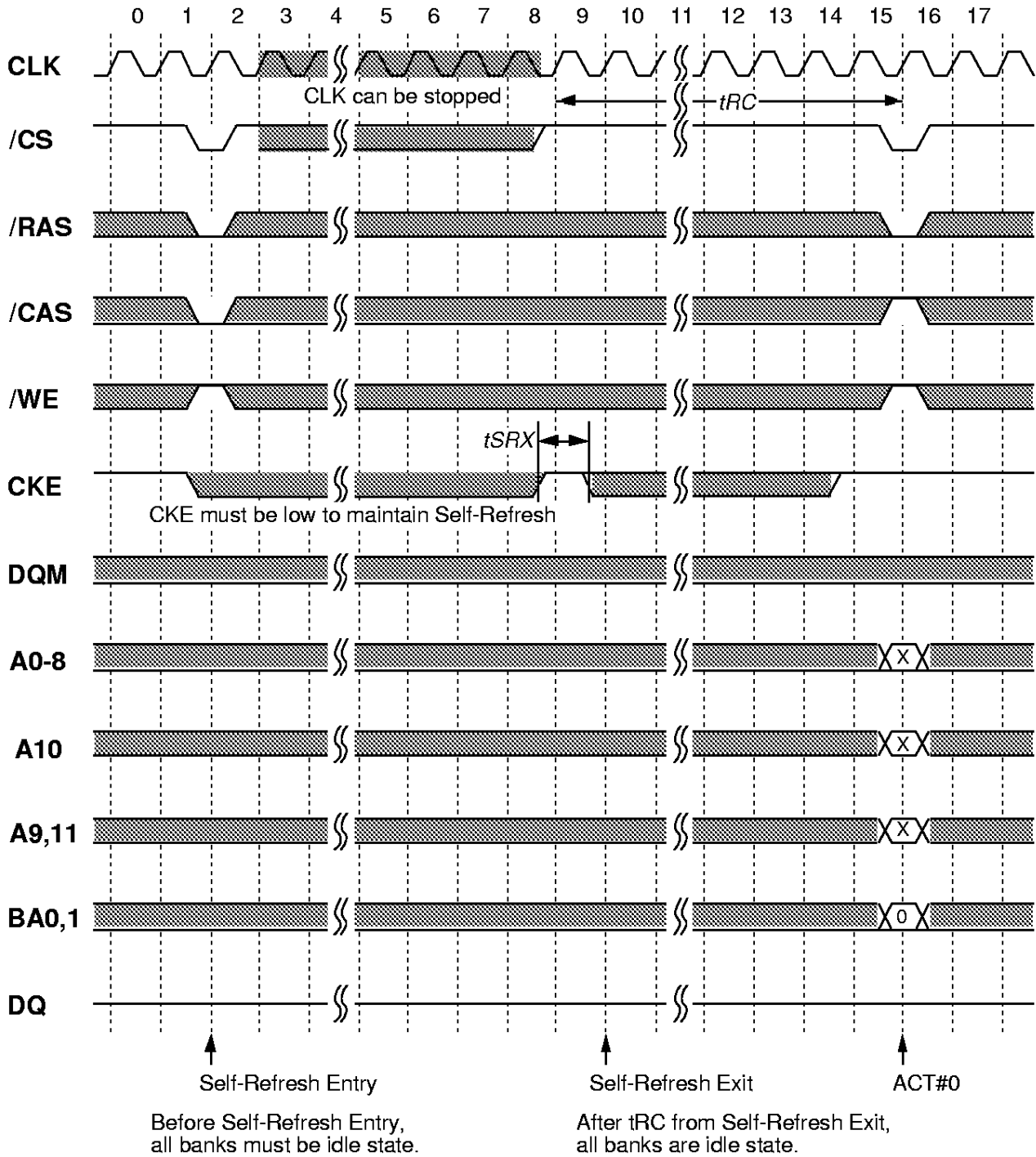

*Italic parameter* indicates minimum case

# MH8S64PHC -7,-8,-10

536870912-BIT (8388608 - WORD BY 64-BIT) Synchronous DRAM

## DQM Write Mask @BL=4

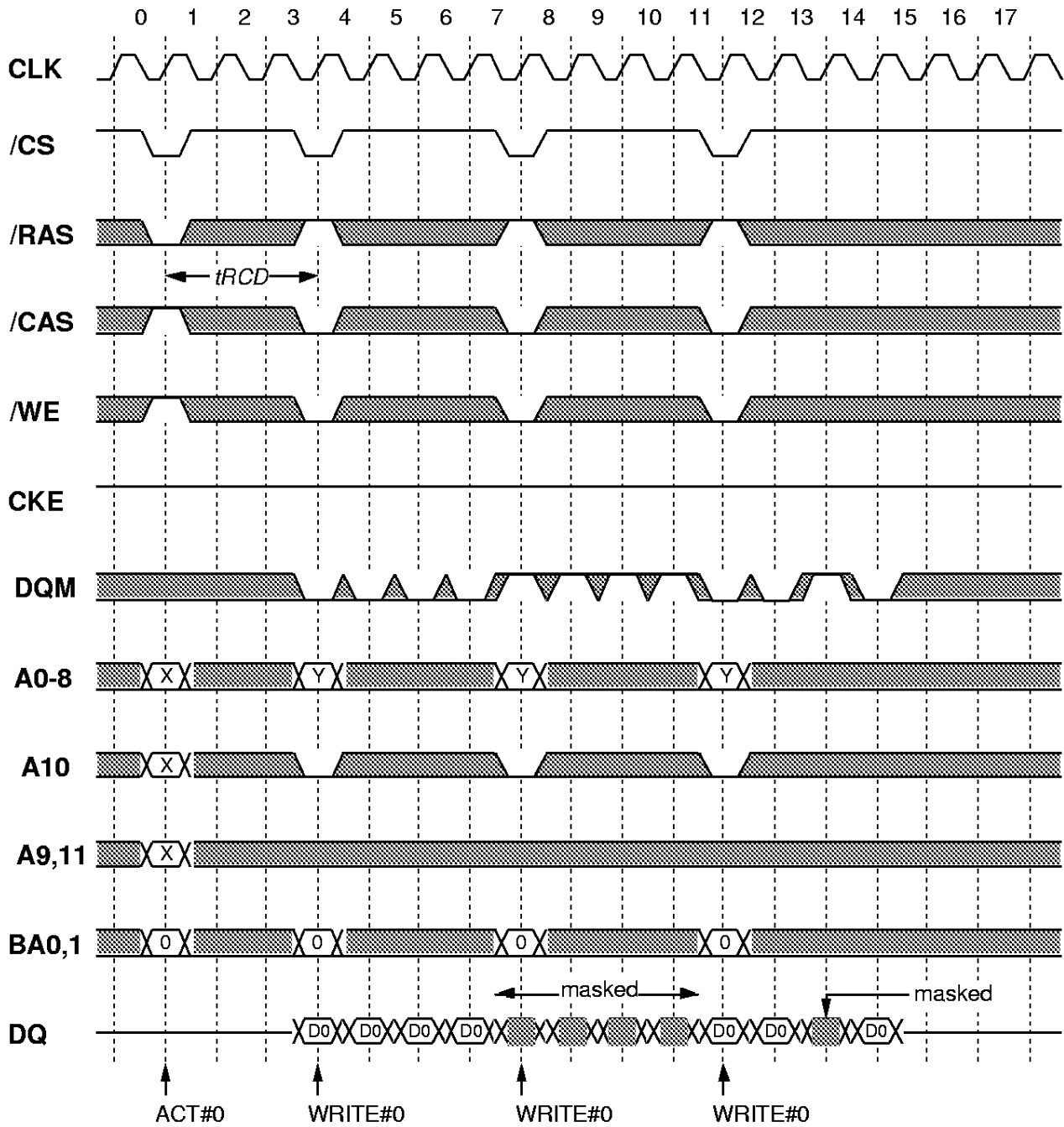

*Italic parameter* indicates minimum case

# MH8S64PHC -7,-8,-10

536870912-BIT (8388608 - WORD BY 64-BIT) Synchronous DRAM

## DQM Read Mask @BL=4 CL=3

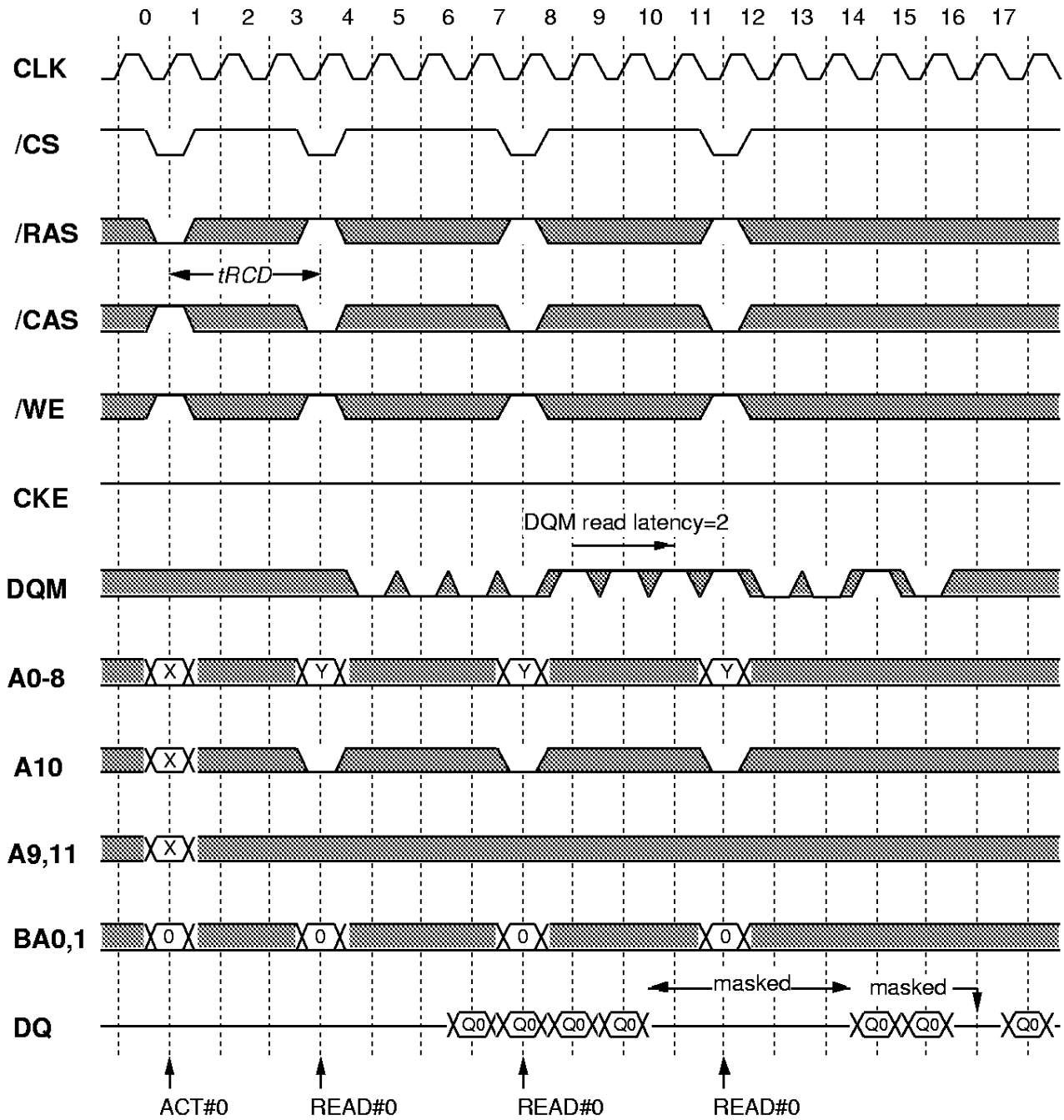

*Italic parameter* indicates minimum case

# MH8S64PHC -7,-8,-10

536870912-BIT (8388608 - WORD BY 64-BIT) Synchronous DRAM

## Power Down

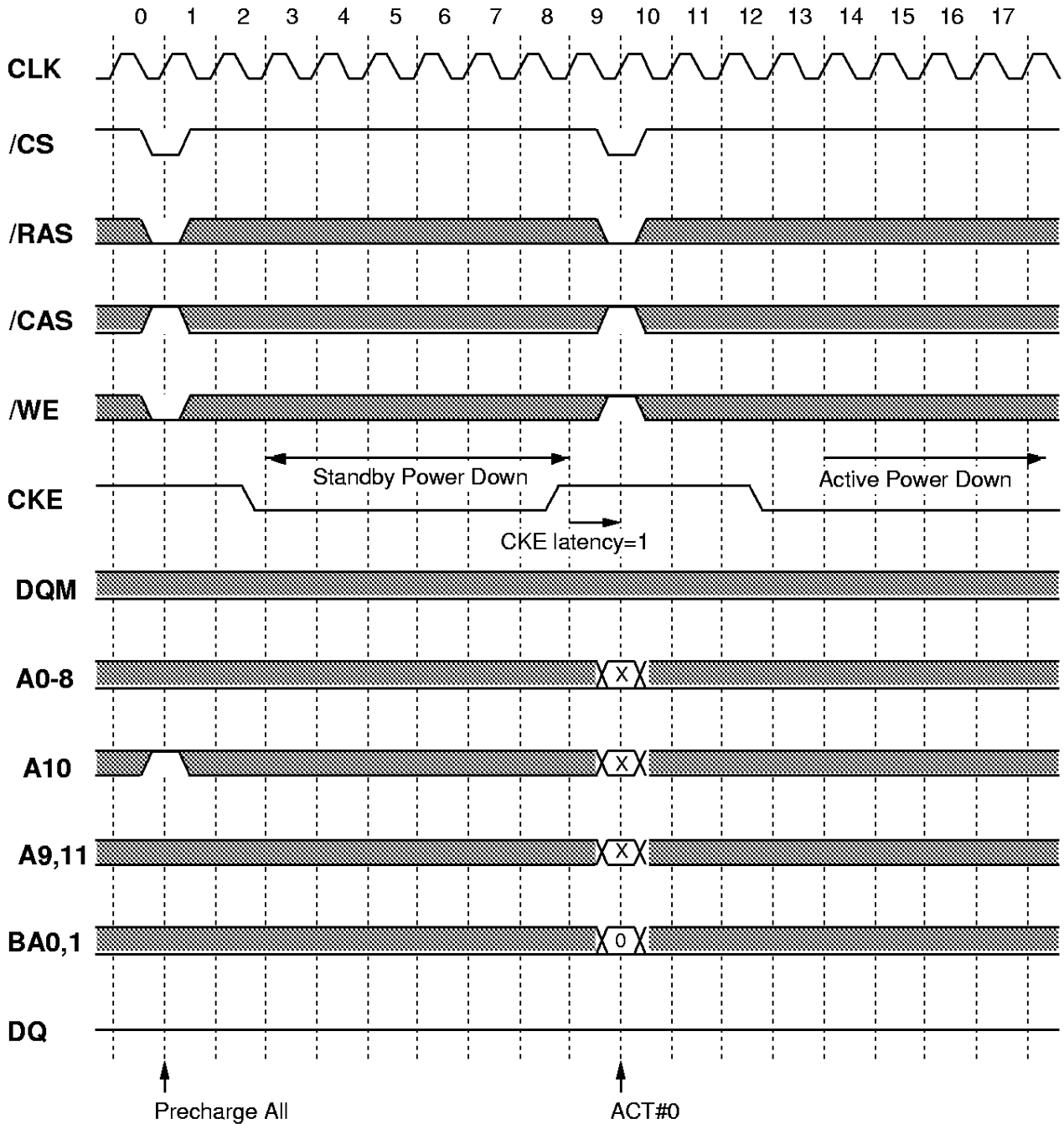

*Italic parameter* indicates minimum case

# MH8S64PHC -7,-8,-10

536870912-BIT (8388608 - WORD BY 64-BIT) Synchronous DRAM

## CLK Suspend @BL=4 CL=3

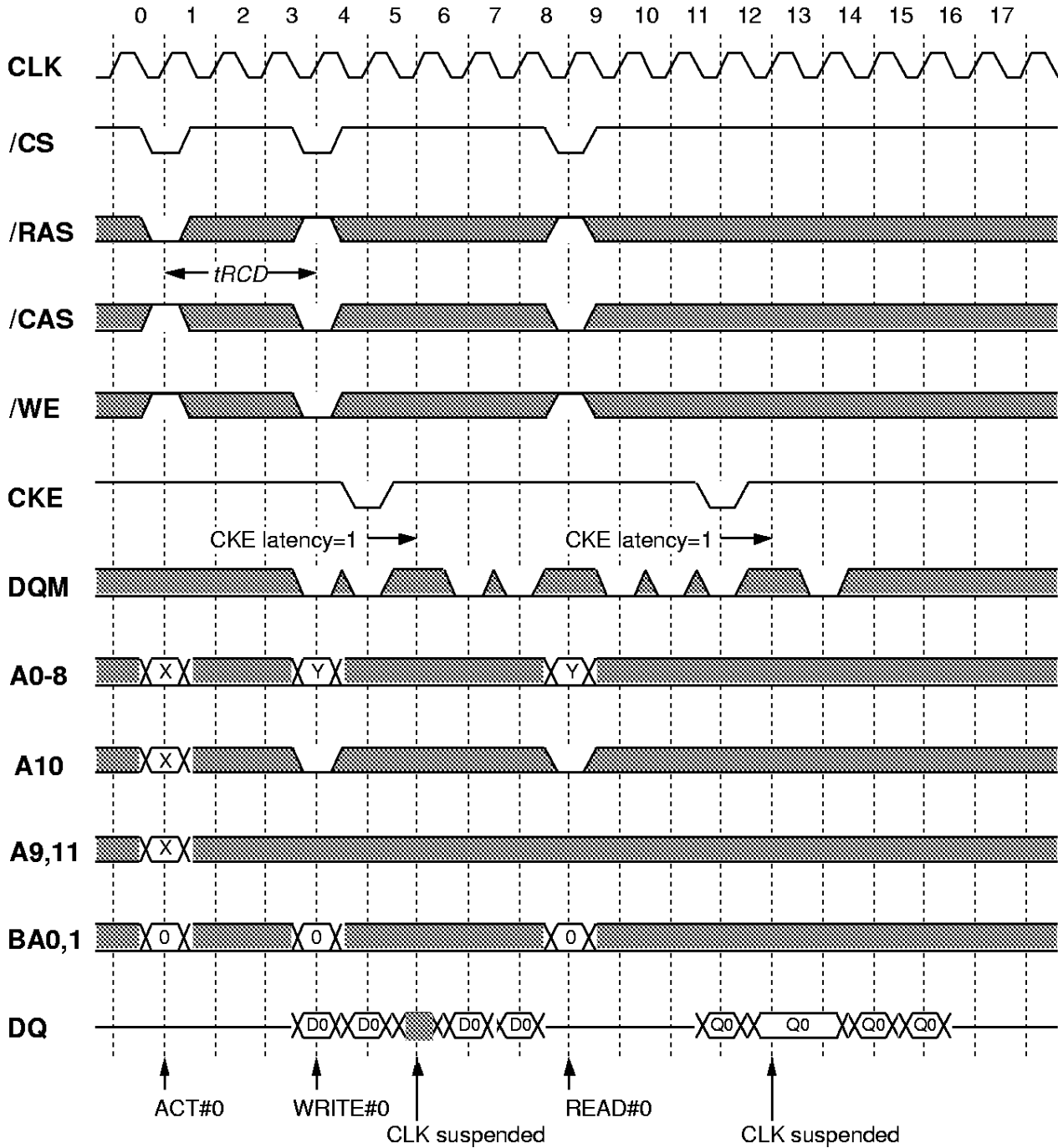

*Italic parameter* indicates minimum case

# MH8S64PHC -7,-8,-10

536870912-BIT (8388608 - WORD BY 64-BIT) Synchronous DRAM

## OUTLINE

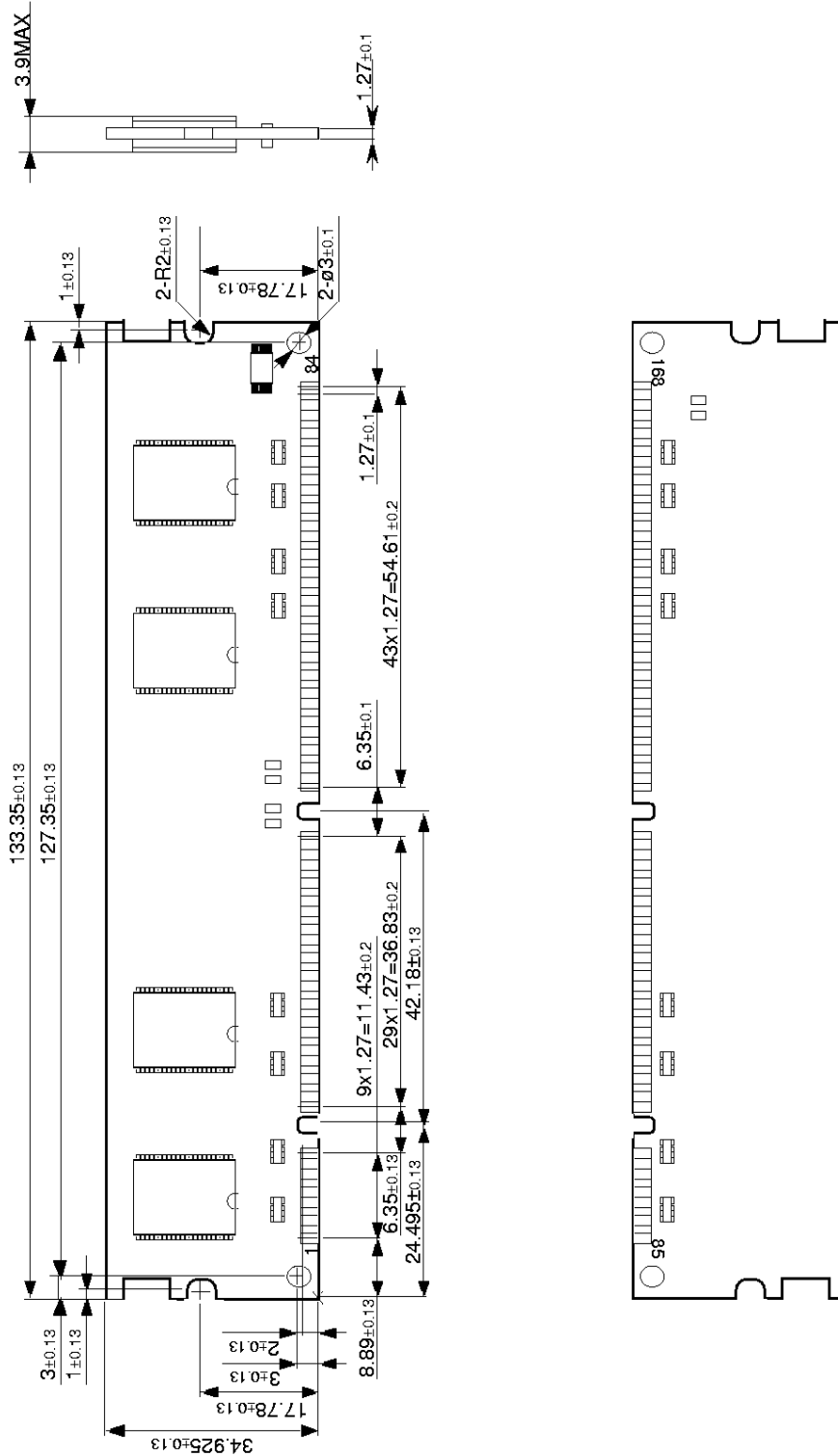

## Keep safety first in your circuit designs!

Mitsubishi Electric Corporation puts the maximum effort into making semiconductor products better and more reliable, but there is always the possibility that trouble may occur with them. Trouble with semiconductors consideration to safety when making your circuit designs, with appropriate measures such as (i) placement of substitutive, auxiliary circuits, (ii) use of non-flammable material or (iii) prevention against any malfunction or mishap.

## Notes regarding these materials

1. These materials are intended as a reference to assist our customers in the selection of the Mitsubishi semiconductor product best suited to the customer's application; they do not convey any license under any intellectual property rights, or any other rights, belonging to Mitsubishi Electric Corporation or a third party.
2. Mitsubishi Electric Corporation assumes no responsibility for any damage, or infringement of any third-party's rights, originating in the use of any product data, diagrams, charts or circuit application examples contained in these materials.
3. All information contained in these materials, including product data, diagrams and charts, represent information on products at the time of publication of these materials, and are subject to change by Mitsubishi Electric Corporation without notice due to product improvements or other reasons. It is therefore recommended that customers contact Mitsubishi Electric Corporation or an authorized Mitsubishi Semiconductor product distributor for the latest product information before purchasing a product listed herein.
4. Mitsubishi Electric Corporation semiconductors are not designed or manufactured for use in a device or system that is used under circumstances in which human life is potentially at stake. Please contact Mitsubishi Electric Corporation or an authorized Mitsubishi Semiconductor product distributor when considering the use of a product contained herein for special applications, such as apparatus or systems for transportation, vehicular, medical, aerospace, nuclear, or undersea repeater use.
5. The prior written approval of Mitsubishi Electric Corporation is necessary to reprint or reproduce in whole or in part these materials.
6. If these products or technologies are subject to the Japanese export control restrictions, they must be exported under a license from the Japanese government and cannot be imported into a country other than the approved destination.  
Any diversion or reexport contrary to the export control laws and regulations of Japan and/or the country of destination is prohibited.
7. Please contact Mitsubishi Electric Corporation or an authorized Mitsubishi Semiconductor product distributor for further details on these materials or the products contained therein.