

TWINAX CONTACT

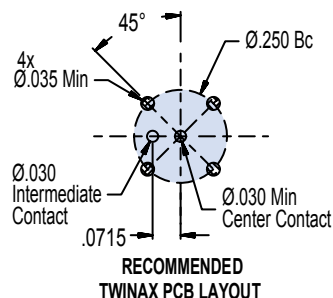

QUADRAX CONTACT

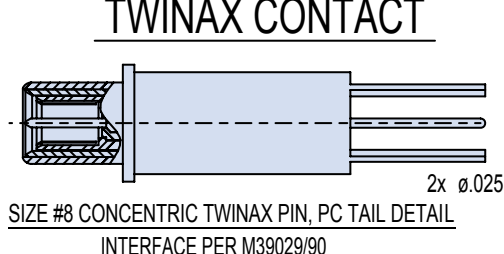
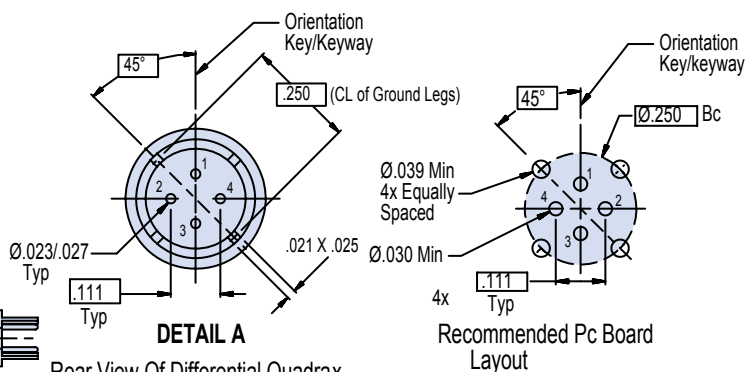
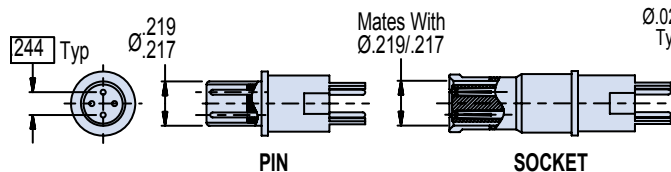

Rear View Of Differential Quadax
Pin Contact (Rear) Shown
Pin no's are for ref only and shall
not be marked.
(Ref. Diferential Pairs: 1 & 3; 2 & 4)