

# HOA1874

## Transmissive Sensor

### FEATURES

- Choice of phototransistor or photodarlington output
- Three sensitivity ranges
- Choice of metal can package or plastic molded components
- 0.120 in. (3.05 mm) slot width

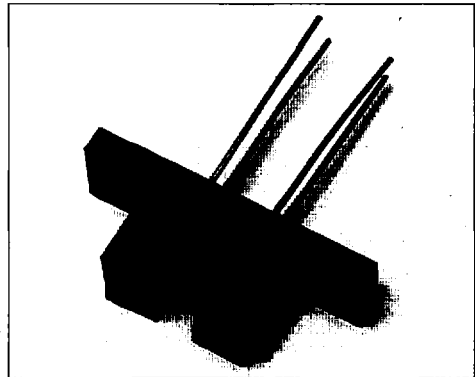

INFR4-5TIF

### DESCRIPTION

The HOA1874 series consists of an infrared emitting diode facing an NPN silicon phototransistor (HOA1874-001, -002, -011, -012) or photodarlington (HOA1874-003, -013) encased in a black thermoplastic housing. Detector switching takes place whenever an opaque object passes through the slot between emitter and detector. The HOA1874-001, -002, and -003 have a 0.050 in. (1.27 mm) dia. detector aperture and employ metal can packaged components, while the HOA1874-011, -012, and -013 have a 0.060 in. (1.52 mm) dia. detector aperture and contain plastic molded components. For additional component information see SE1450, SD1440, SD1410, SEP8506, SDP8406, and SDP8106.

HOA1874-001, 002, 003 housing material is acetal copolymer. HOA1874-011, 012, 013 housing material is polyester. Housings are soluble in chlorinated hydrocarbons and ketones. Recommended cleaning agents are methanol and isopropanol.

### OUTLINE DIMENSIONS in inches (mm)

Tolerance 3 plc decimals  $\pm 0.010(0.25)$   
2 plc decimals  $\pm 0.020(0.51)$

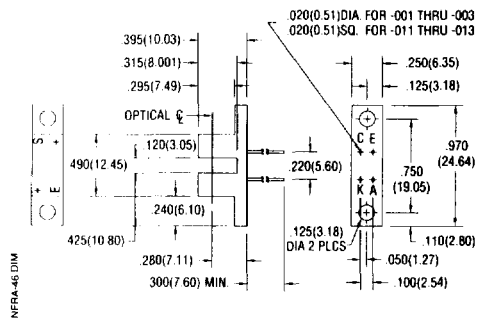

# Honeywell

Honeywell reserves the right to make changes in order to improve design and supply the best products possible.

# HOA1874

## Transmissive Sensor

### ELECTRICAL CHARACTERISTICS (25°C unless otherwise noted)

PARAMETER	SYMBOL	MIN	TYP	MAX	UNITS	TEST CONDITIONS
<b>IR EMITTER</b>						
Forward Voltage	$V_F$			1.6	V	$I_F=20\text{ mA}$
Reverse Leakage Current	$I_R$			10	$\mu\text{A}$	$V_R=3\text{ V}$
<b>DETECTOR</b>						
Collector-Emitter Breakdown Voltage	$V_{(BR)CEO}$				V	$I_C=100\text{ }\mu\text{A}$
HOA1874-001, -002, -011, -012		30				
HOA1874-003, -013		15				
Emitter-Collector Breakdown Voltage	$V_{(BR)ECO}$	5.0			V	$I_E=100\text{ }\mu\text{A}$
Collector Dark Current	$I_{CEO}$				nA	$V_{CE}=10\text{ V}$
HOA1874-001, -002, -011, -012				100		$I_F=0$
HOA1874-003, -013				250		
<b>COUPLED CHARACTERISTICS</b>						
On-State Collector Current	$I_{C(ON)}$				mA	$V_{CE}=5\text{ V}$
HOA1874-001, -011		0.3				$I_F=20\text{ mA}$
HOA1874-002, -012		1.8				
HOA1874-003, -013		4.0				
Collector-Emitter Saturation Voltage	$V_{CE(SAT)}$				V	$I_F=20\text{ mA}$
HOA1874-001, -011				0.4		$I_C=40\text{ }\mu\text{A}$
HOA1874-002, -012				0.4		$I_C=230\text{ }\mu\text{A}$
HOA1874-003, -013				1.1		$I_C=500\text{ }\mu\text{A}$
Rise And Fall Time	$t_r, t_f$				$\mu\text{s}$	$V_{CC}=5\text{ V}, I_C=1\text{ mA}$
HOA1874-001, -002, -011, -012			15			$R_L=1000\text{ }\Omega$
HOA1874-003, -013			75			$R_L=100\text{ }\Omega$

### ABSOLUTE MAXIMUM RATINGS

(25°C Free-Air Temperature unless otherwise noted)

<b>Operating Temperature Range</b>	
HOA1874-001, -002, -003	-55°C to 100°C
HOA1874-011, -012, -013	-40°C to 85°C
<b>Storage Temperature Range</b>	
HOA1874-001, -002, -003	-55°C to 125°C
HOA1874-011, -012, -013	-40°C to 85°C
<b>Soldering Temperature</b>	
HOA1874-001, -002, -003	260°C (10 sec)
HOA1874-011, -012, -013	240°C (5 sec)

### IR EMITTER

<b>Power Dissipation</b>	
HOA1874-001, -002, -003	75 mW <sup>(1)</sup>
HOA1874-011, -012, -013	100 mW <sup>(2)</sup>
Reverse Voltage	3 V
Continuous Forward Current	50 mA

### ABSOLUTE MAXIMUM RATINGS (continued)

	<b>DETECTOR</b>	<b>TRANS.</b>	<b>DARLINGTON</b>
Collector-Emitter Voltage	30 V	15 V	15 V
Emitter-Collector Voltage	5 V	5 V	5 V
<b>Power Dissipation</b>			
HOA1874-001, -002, -003	75 mW <sup>(1)</sup>	75 mW <sup>(1)</sup>	75 mW <sup>(1)</sup>
HOA1874-011, -012, -013	100 mW <sup>(2)</sup>	100 mW <sup>(2)</sup>	100 mW <sup>(2)</sup>
Collector DC Current	30 mA	30 mA	30 mA

### Notes

- Derate linearly at 0.71 mW/°C above 25°C.
- Derate linearly at 0.78 mW/°C above 25°C.

Honeywell reserves the right to make changes in order to improve design and supply the best products possible.

# Honeywell



# HOA1874

## Transmissive Sensor

### SCHEMATIC

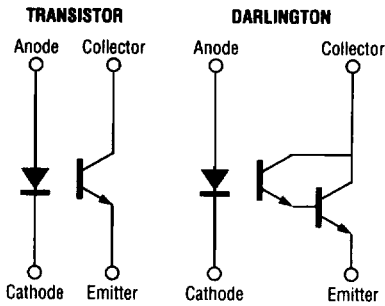

Fig. 2 Non-Saturated Switching Time vs Load Resistance

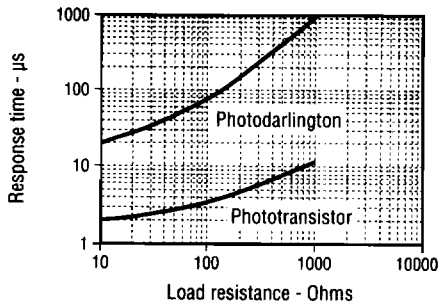
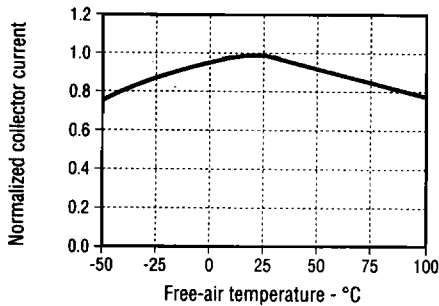

Fig. 4 Collector Current vs Ambient Temperature



All Performance Curves Show Typical Values

Fig. 1 IRED Forward Bias Characteristics

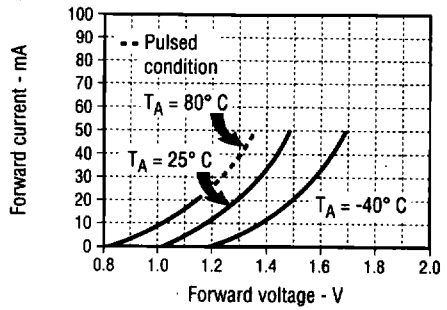
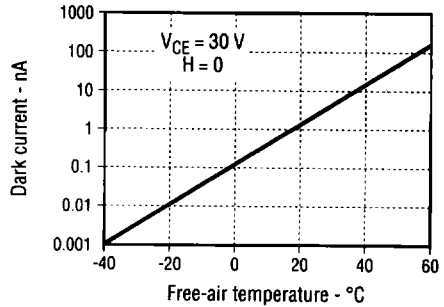

Fig. 3 Detector Dark Current vs Temperature



**Honeywell**

Honeywell reserves the right to make changes in order to improve design and supply the best products possible.