

# SED1345

## CMOS VIDEO - LCD INTERFACE (VLI)

### ● 8 Levels of Gray Scale

#### ■ DESCRIPTION

The SED1345 is a video-LCD interface (VLI) developed for a dot matrix LCD display system. It converts separate video signals for CRT display into signals for LCD.

The SED1345 can use a conventional LCD driver to display data at eight gradation levels corresponding to digital video signal data I, R, G and B. The on-chip color pallet for gradation display allows setting of any gradation level for each of the 16 colors on the CRT display.

A 640 × 480 dot panel with eight gradation levels can be driven using only 256K bits of frame buffer memory. This leads to a significant reduction in system memory cost.

With the SED1345, the user can select not only a display size but a display area to configure a display panel of flexible size from 640 × 200 dots to 640 × 480 dots (maximum). These LCD display sizes are compatible with various display modes such as CGA® and EGA®.

#### ■ FEATURES

- Low-power CMOS technology
- TTL-compatible signal input
- LCD display size:
  - Horizontal: ..... 640 dots
  - Vertical: ..... 200, 350, 400, 480 lines
- Supports 8 levels of gray shade
- Supports single panel and dual panel
- LCD driver interface: 4 bits bus and 4 bits × 2 bus
- Register programming by 4 bits
- Maximum dot clock: ..... 30 MHz
- Supports 40KB SRAM frame buffer
- Duty cycle: ..... 1/200 to 1/480
- Power-on clear function
- Single power supply: ..... 5V ± 5%
- Package: ..... QFP5-80 pin (FOA)

#### ■ SYSTEM BLOCK DIAGRAM

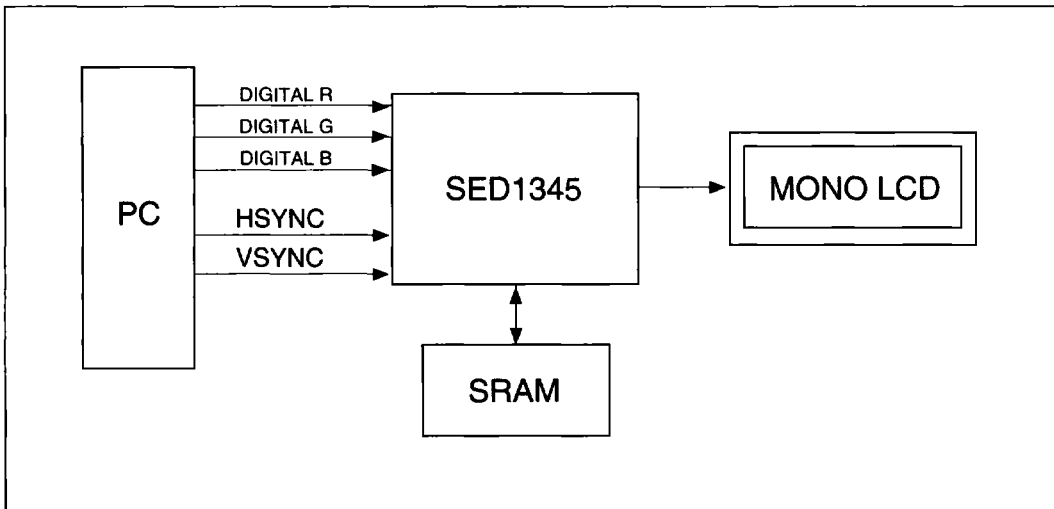

■ BLOCK DIAGRAM

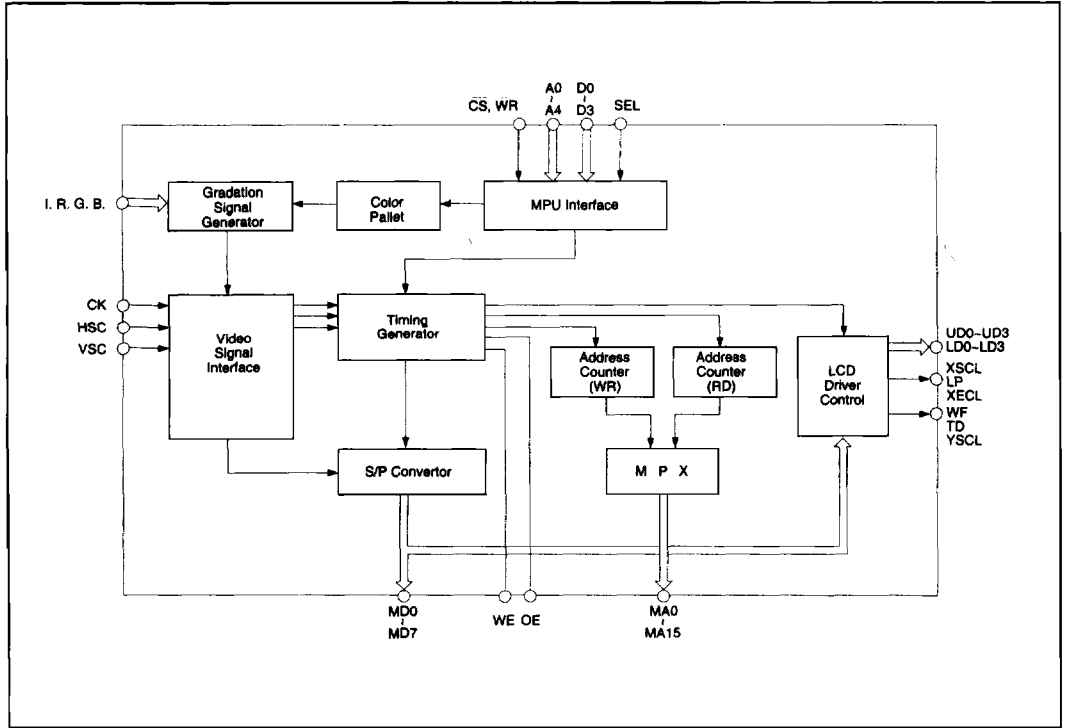

■ PIN OUT

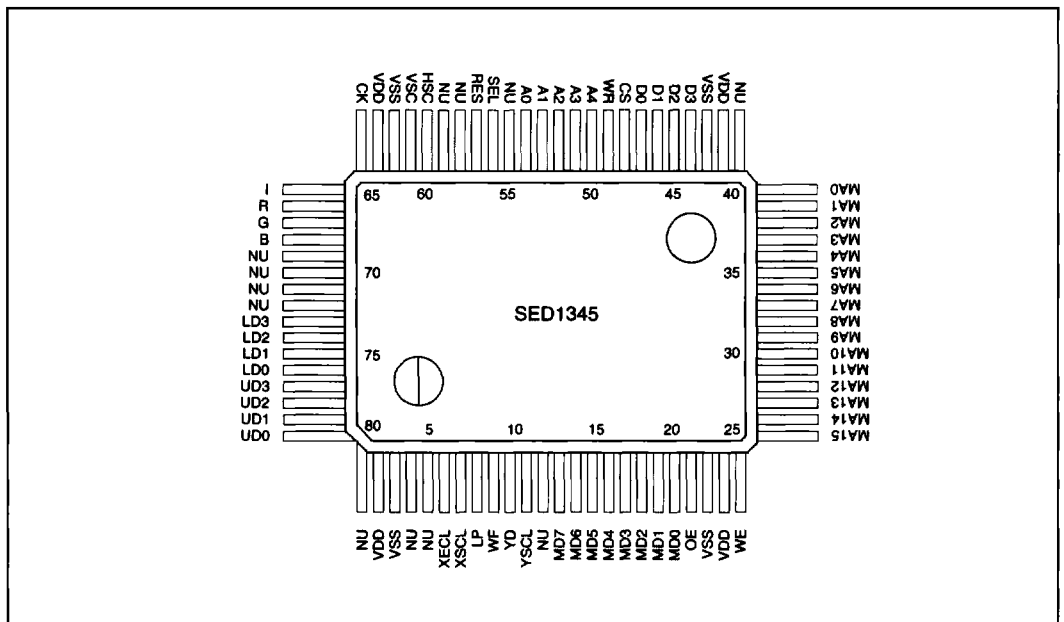

## ■ PIN OUT

No.	Name	No.	Name	No.	Name	No.	Name
1	NU	21	OE	41	NU	61	VSC
2	VDD	22	VSS	42	VDD	62	VSS
3	VSS	23	VDD	43	VSS	63	VDD
4	NU	24	WE	44	D3	64	CK
5	NU	25	MA15	45	D2	65	I
6	XECL	26	MA14	46	D1	66	R
7	XSCL	27	MA13	47	D0	67	G
8	LP	28	MA12	48	CS	68	B
9	WF	29	MA11	49	WR	69	NU
10	YD	30	MA10	50	A4	70	NU
11	YSCL	31	MA9	51	A3	71	NU
12	NU	32	MA8	52	A2	72	NU
13	MD7	33	MA7	53	A1	73	LD3
14	MD6	34	MA6	54	A0	74	LD2
15	MD5	35	MA5	55	NU	75	LD1
16	MD4	36	MA4	56	SEL	76	LD0
17	MD3	37	MA3	57	RES	77	UD3
18	MD2	38	MA2	58	NU	78	UD2
19	MD1	39	MA1	59	NU	79	UD1
20	MD0	40	MA0	60	HSC	80	UD0

Note: NU = Pin is Not Used

The NU pin is wired to the IC chip inside the package, and must be held open.

## ■ PIN DESCRIPTION

Pin Name	Pin No.	Function
VDD	2, 23, 42, 63	+5V power
VSS	3, 22, 43, 62	GND
UD0 to UD3	80 to 77	Data bus output to X-driver
LD0 to LD3	76 to 73	Data bus output to X-driver
XSCL	7	Shift clock output to X-driver
LP	8	Latch pulse output
XECL	6	Enable shift clock output to X-driver
WF	9	LCD AC signal output
YD	10	Scanning start data output to Y-driver
YSCL	11	Shift clock output to Y-driver
I, R, G, B	65 to 68	Video data input
CK	64	Dot clock input
HSC	60	Horizontal sync signal input
VSC	61	Vertical sync signal input
MA0 to MA15	40 to 25	Address bus output to frame buffer memory
MD0 to MD7	20 to 13	Data bus input/output to frame buffer memory
WE	24	Write enable signal output
OE	21	Output enable signal output
D0 to D3	47 to 44	Data bus input for writing registers
A0 to A4	54 to 50	Address bus input/output for writing registers
CS	48	Chip select signal input
WR	49	Write signal input
SEL	56	Register write mode selection input (ROM/MPU)
RES	57	Reset signal input

■ ELECTRICAL CHARACTERISTICS

● Absolute Maximum Ratings

(V<sub>SS</sub> = 0V)

Parameter	Symbol	Condition	Ratings	Unit
Supply Voltage	V <sub>DD</sub>	Based on V <sub>SS</sub>	-0.3 to 7.0	V
Input Voltage	V <sub>I</sub>		-0.3 to V <sub>DD</sub> +0.3	V
Output Voltage	V <sub>O</sub>		-0.3 to V <sub>DD</sub> +0.3	V
I/O Voltage	V <sub>I/O</sub>		-0.3 to V <sub>DD</sub> +0.3	V
Output Current/Pin	I <sub>O</sub>		-10 to 10	mA
Power Dissipation	P <sub>D</sub>		250	mW
Operating Temperature	T <sub>opr</sub>		0 to 70	°C
Storage Temperature	T <sub>stg</sub>		-65 to 150	°C
Soldering Temperature and Time	T <sub>sol</sub>		260°C, 10s (at lead)	—

● Recommended Operating Conditions

(V<sub>SS</sub> = 0V)

Parameter	Symbol	Condition	Min	Typ	Max	Unit
Supply Voltage	V <sub>DD</sub>		4.75	5.00	5.25	V

● DC Characteristics

(V<sub>DD</sub> = 5V±5%, V<sub>SS</sub> = 0V, T<sub>a</sub> = 0 to 70°C)

Parameter	Symbol	Condition	Min	Typ	Max	Unit
Average Operating Current Consumption	I <sub>opr</sub>	f <sub>clk</sub> =24MHz	—	—	40	mA
High Voltage Input Voltage 1	V <sub>IH1</sub>	*1	2.0	—	V <sub>DD</sub> +0.3	V
Low Level Input Voltage 1	V <sub>IL1</sub>		-0.3	—	0.8	V
High Level Input Voltage 2	V <sub>IH2</sub>	*2	4.0	—	V <sub>DD</sub> +0.3	V
Low Level Input Voltage 2	V <sub>IL2</sub>		-0.3	—	0.8	V
High Level Input Voltage 3	V <sub>IH3</sub>	*3	3.0	—	V <sub>DD</sub> +0.3	V
Low Level Input Voltage 3	V <sub>IL3</sub>		-3.0	—	0.6	V
High Level Output Voltage	V <sub>OH</sub>	I <sub>OH</sub> = -2mA	4.35	—	—	V
Low Level Output Voltage	V <sub>OL</sub>	I <sub>OL</sub> = 6mA	—	—	0.4	V
Input Current Leakage	I <sub>LI</sub>	V <sub>I</sub> = 0V to V <sub>DD</sub>	-1	—	1	μA
I/O Current Leakage	I <sub>LI/O</sub>	V <sub>I/O</sub> = 0V to V <sub>DD</sub>	-1	—	1	μA

\*1 Pad: I, R, G, B, CK, HSC, VSC, MD0 to MD7, A0 to A4,  $\overline{CS}$ ,  $\overline{WR}$

\*2 Pad: D0 to D3, SEL

\*3 Pad:  $\overline{RES}$

(V<sub>DD</sub> = 5V±5%, V<sub>SS</sub> = 0V, T<sub>a</sub> = 0 to 70°C)

Parameter	Symbol	Condition	Min	Typ	Max	Unit
Output Rise Time	t <sub>ri</sub>	CL = 150pF	—	—	50	ns
Output Fall Time	t <sub>fl</sub>	CL = 150pF	—	—	50	ns

● AC CHARACTERISTICS  
 ○ LCD Interface Timing Chart

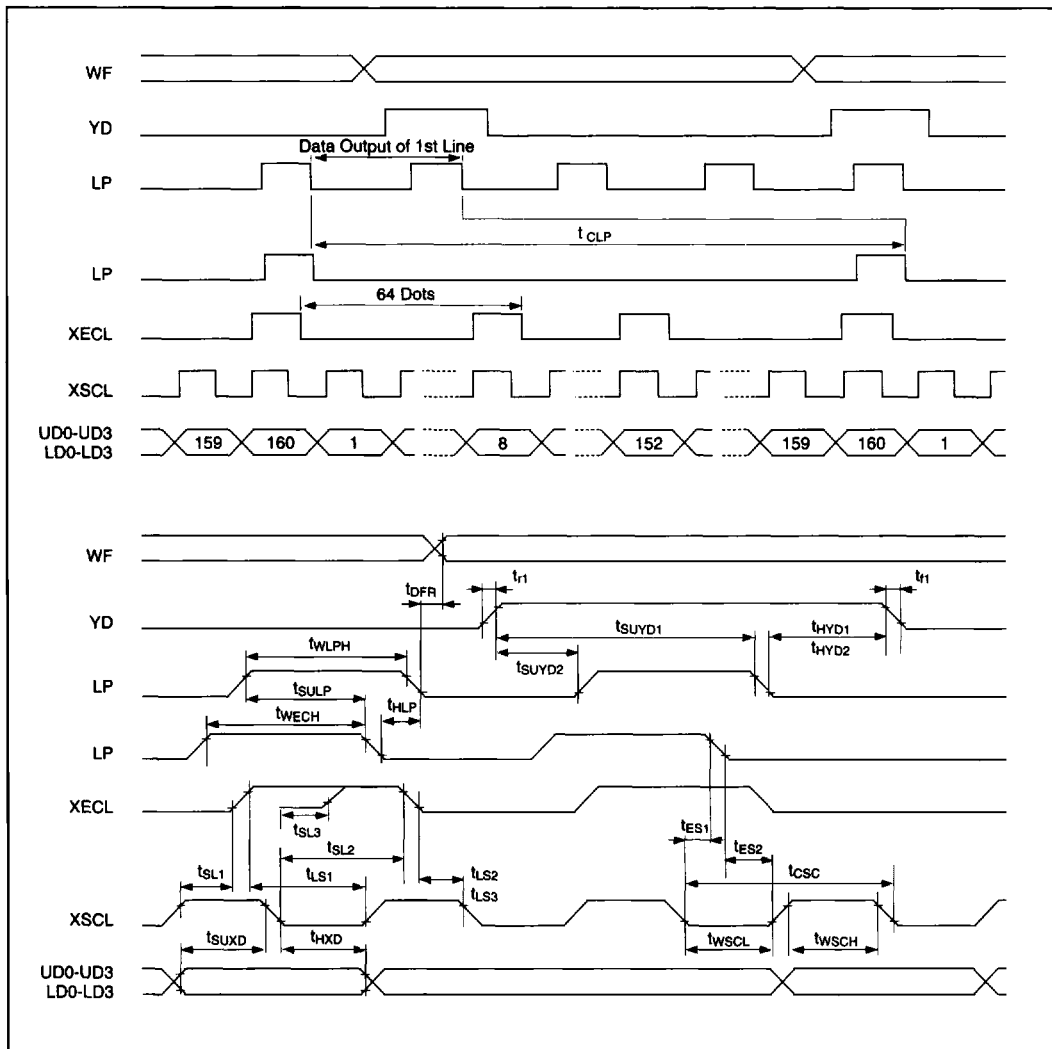

Output Signal Reference Level: "H" = V<sub>DD</sub> × 0.8V  
 "L" = V<sub>DD</sub> × 0.2V

o X Driver

(VDD = 5V±5%, VSS = 0V, Ta = 0 to 70°C)

Parameter	Symbol	Condition	Min	Typ	Max	Unit		
XSCL Cycle Time	tcsc	S6 = "H"	2t1	—	—	ns		
		S6 = "L"	4t1					
XSCL "H" Pulse Width	twSCH	S6 = "H"	t1-20	—	—	ns		
		S6 = "L"	2t1-20					
XSCL "L" Pulse Width	twSCL	S6 = "H"	t1-20	—	—	ns		
		S6 = "L"	2t1-20					
UD0-3, LD0-3 Setup Time before XSCL	tsUXD	S6 = "H"	t1-30	—	—	ns		
		S6 = "L"	2t1-30					
UD0-3, LD0-3 Hold Time after XSCL	thXD	S6 = "H"	21-30	—	—	ns		
		S6 = "L"	2t1-30					
XSCL to LP Time	tSL1	S5 = "H"	S6 = "H"	0.5t1-30	—	—	ns	
			S6 = "L"	t1-30				
XSCL to LP Time	tSL2		S6 = "H"	t1-20	—	—	ns	
			S6 = "L"	2t1-20				
LP to XSCL Time	tLS1		S6 = "H"	1.5t1-50	—	—	ns	
			S6 = "L"	3t1-50				
LP to XSCL Time	tLS2		S6 = "H"	t1-20	—	—	ns	
			S6 = "L"	2t1-20				
XSCL to LP Time	tSL3		S5 = "L"	S6 = "H"	0.5t1-40	—	—	ns
				S6 = "L"	t1-40			
LP to XSCL Time	tLS3	S6 = "H"		0.5t1-40	—	—	ns	
		S6 = "L"		t1-40				
LP Cycle Time	tCLP	S0 = "H"		320t1	—	—	ns	
		S0 = "L"		640t1				
LP, YSCL "H" Pulse Width	twLPH	S5 = "H"	S6 = "H"	1.5t1-50	—	—	ns	
			S6 = "L"	3t1-50				
		S5 = "L"	S6 = "H"	t1-40	—	—	ns	
			S6 = "L"	2t1-40				
LP Setup Time before XECL	tsULP	S5 = "H", S6 = "H"	t1-50	—	—	ns		
LP Hold Time after XECL	thLP	S5 = "H", S6 = "H"	0.5t1-40	—	—	ns		
XSCL to XECL Time	tes1	S5 = "H", S6 = "H"	0.5t1-30	—	—	ns		
XECL to XSCL Time	tes2	S5 = "H", S6 = "H"	0.5t1-40	—	—	ns		
XECL "H" Pulse Width	tWECH	S5 = "H", S6 = "H"	1.5t1-50	—	—	ns		
WF Output Delay Time After LP, YSCL	tDFR	S5 = "H", S6 = "H"	—	—	100	ns		

t1 = 2tclk (tclk = dot clock cycle)

o Y Driver

(V<sub>DD</sub> = 5V±5%, V<sub>SS</sub> = 0V, T<sub>a</sub> = 0 to 70°C)

Parameter	Symbol	Condition	Min*	Typ	Max	Unit	
YD Setup Time before LP, YSCL	tsUYD1	S5 = "H"	S0 = "H"	142t1-100	—	—	ns
			S0 = "L"	302t1-100			
YD Hold Time after LP, YSCL	thYD1		S0 = "H"	18t1-100	—	—	ns
			S0 = "L"	18t1-100			
YD Setup Time before LP, YSCL	tsUYD2	S5 = "L"	S0 = "H"	S6 = "H"	—	—	ns
				S6 = "L"			
			S0 = "L"	S6 = "H"	301.5t1-100		
				S6 = "L"	301t1-100		
YD Hold Time after LP, YSCL	thYD2		S0 = "H"	S6 = "H"	—	—	ns
				S6 = "L"			
			S0 = "L"	S6 = "H"	17.5t1-100		
				S6 = "L"	17t1-100		

t1=2t<sub>CCK</sub> (t<sub>CCK</sub> = dot clock cycle)

(V<sub>DD</sub> = 5V±5%, V<sub>SS</sub> = 0V, T<sub>a</sub> = 0 to 70°C)

Parameter	Symbol	Condition	Min	Typ	Max	Unit
CK Cycle Time	t <sub>CCK</sub>		33	—	—	ns
CK "H" Pulse Width	tw <sub>CCKW</sub>		12	—	—	ns
CK "L" Pulse Width	tw <sub>CCKL</sub>		12	—	—	ns
Input Rise Time	tr <sub>2</sub>		—	—	5	ns
Input Fall Time	tf <sub>2</sub>		—	—	5	ns
VD Setup Time Before CK	ts <sub>VD</sub>		16	—	—	ns
VD Hold Time After CK	th <sub>VD</sub>		2	—	—	ns
CK Setup Time Before HSC	ts <sub>UCK</sub>		20	—	—	ns
CK Hold Time After HSC	th <sub>CK</sub>		0	—	—	ns
HSC Setup Time Before VSC	ts <sub>UVH</sub>		80	—	—	ns
HSC Hold Time After VSC	th <sub>VM</sub>		0	—	—	ns
Active Pulse Width HSC	t <sub>WH1</sub>		8t <sub>CCK</sub>	—	—	ns
Non-Active Pulse Width HSC	t <sub>WH2</sub>		64t <sub>CCK</sub>	—	—	ns

- Memory Interface
- Read Cycle

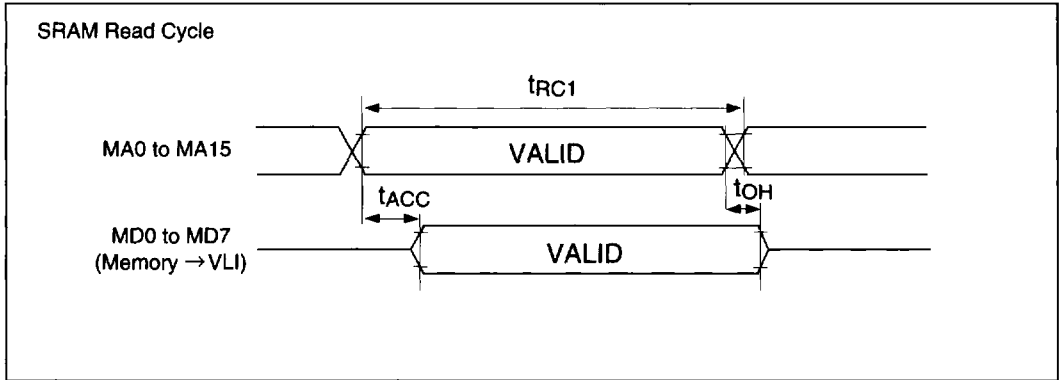

( $V_{DD} = 5V \pm 5\%$ ,  $V_{SS} = 0V$ ,  $T_a = 0$  to  $70^\circ C$ )

Parameter	Symbol	Condition	Min	Typ	Max	Unit
Read Cycle Time	$t_{RC1}$		$4t_{CCK}$	—	—	ns
Address Access Time	$t_{ACC}$		—	—	$4t_{CCK} - 17$	ns
Output Hold Time	$t_{OH}$		10	—	—	ns



○ Write Cycle

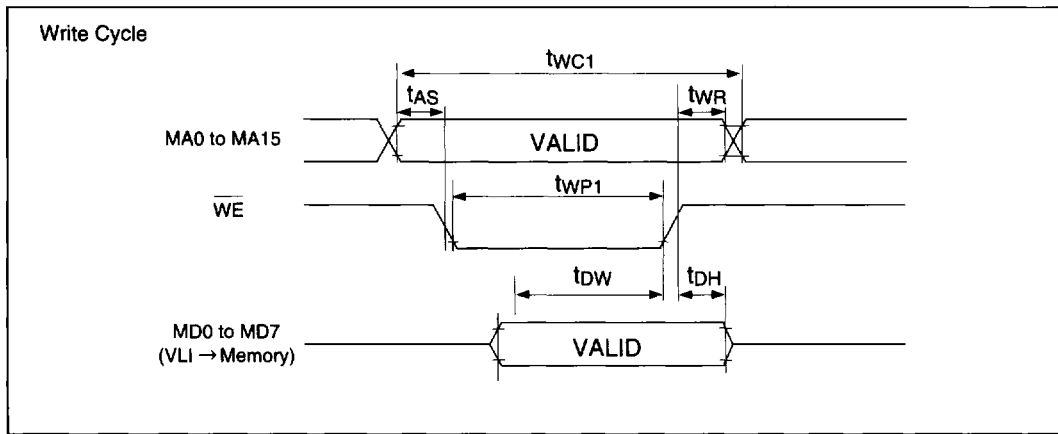

(VDD = 5V±5%, VSS = 0V, Ta = 0 to 70°C)

Parameter	Symbol	Condition	Min*	Typ	Max	Unit
Write Cycle Time	tWC1		4tCCK	—	—	ns
Write Pulse Width	tWP1		3tCCK-13	—	—	ns
Address Setup Time	tAS		0.5tCCK-14	—	—	ns
Address Hold Time	tWR		0.5tCCK-14	—	—	ns
Data Setup Time	tdw		3tCCK-38	—	—	ns
Data Hold Time	tDH		5	—	—	ns

Input/Output Signal Reference Level: "H" = 2.0V "L" = 0.8V

\*tCCK is the cycle time of dot clock (tCCK = 1/fCK).

- Register Program
  - Write Data Using MPU

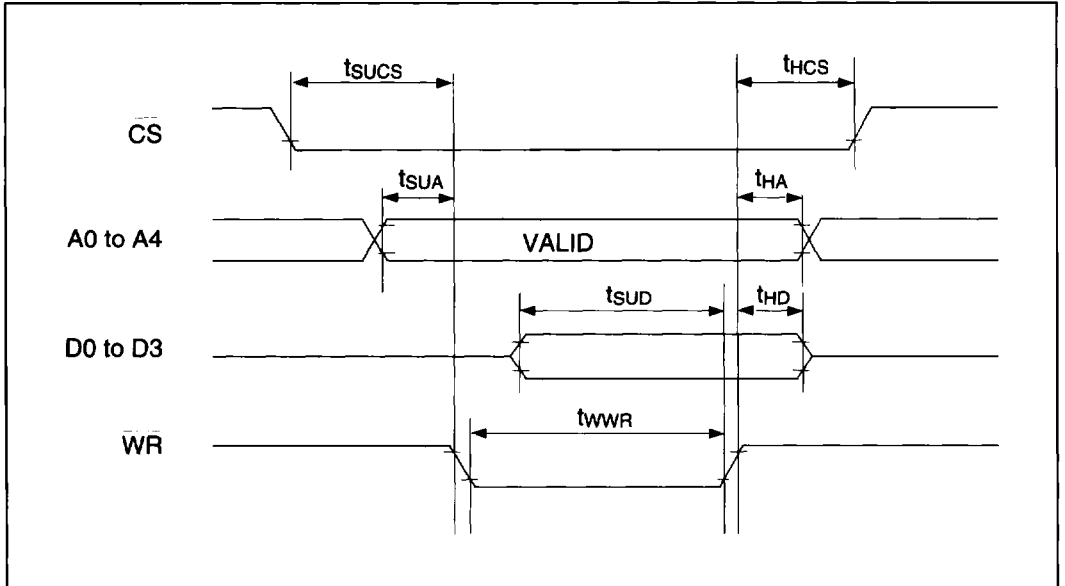

(VDD = 5V±5%, VSS = 0V, Ta = 0 to 70°C)

Parameter	Symbol	Condition	Min	Typ	Max	Unit
$\overline{CS}$ Setup Time	$t_{sucs}$		50	—	—	ns
$\overline{CS}$ Hold Time	$t_{hcs}$		50	—	—	ns
A0–A4 Setup Time	$t_{sua}$		50	—	—	ns
A0–A4 Hold Time	$t_{ha}$		50	—	—	ns
D0–D3 Setup Time	$t_{sud}$		100	—	—	ns
D0–D3 Hold Time	$t_{hd}$		50	—	—	ns
$\overline{WR}$ Pulse Width	$t_{wwr}$		50	—	—	ns

● Write Data Using ROM

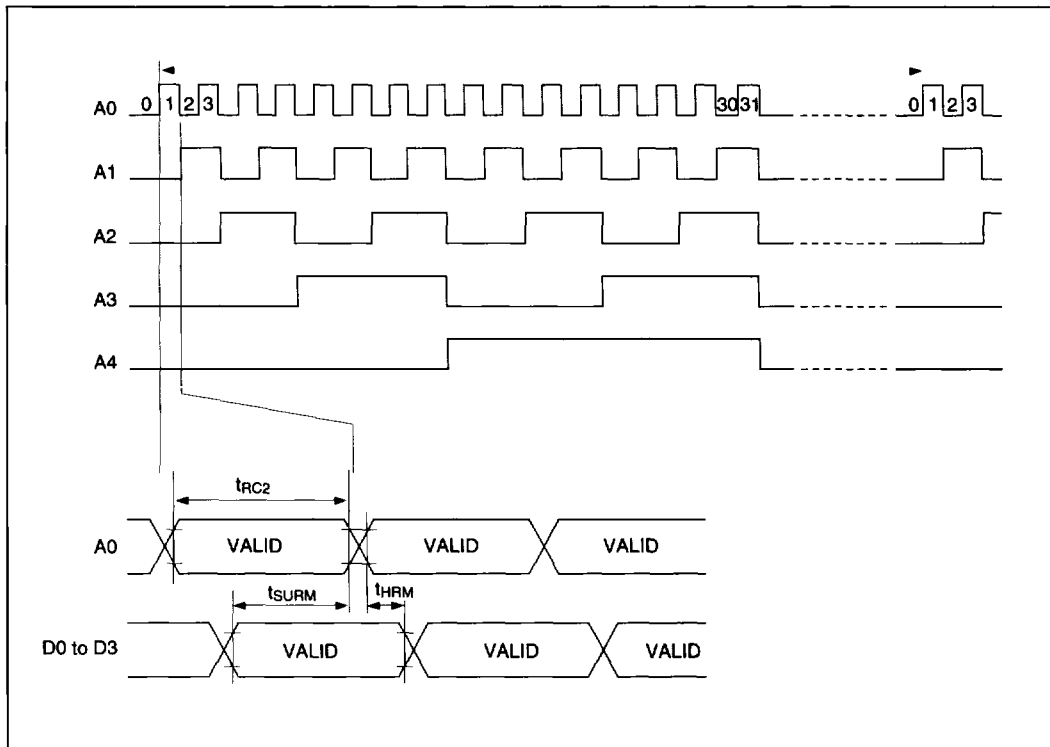

Input/output signal level identification voltages:

"H" level – 2.0V

"L" level – 0.8V

( $V_{DD} = 5V \pm 5\%$ ,  $V_{SS} = 0V$ ,  $T_a = 0$  to  $70^\circ C$ )

Parameter	Symbol	Condition	Min*	Typ	Max	Unit
ROM Read Cycle Time	$t_{RC2}$		81-100	—	—	ns
D0 to D3 Setup Time	$t_{SURM}$		100	—	—	ns
D0 to D3 Hold Time	$t_{HRM}$		10	—	—	ns

\*  $t_1 = 2t_{CLK}$  ( $t_{CLK}$  is a cycle time of dot clock)

● Reset Input

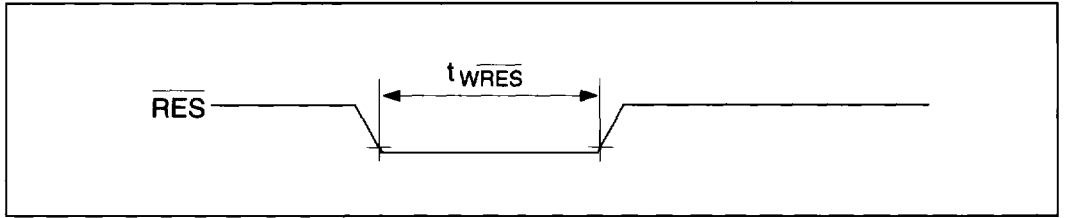

(VDD = 5V±5%, VSS = 0V, Ta = 0 to 70°C)

Parameter	Symbol	Condition	Min	Typ	Max	Unit
RES Pulse Width	twRES		1.0	—	—	ns

Input signal reference level: "H" = 2.0V "L" = 0.8V

t<sub>CK</sub> is a cycle time of dot clock (t<sub>CK</sub> = 1/f<sub>CK</sub>)

● System Configuration

