

Technical Data

S1633 Series

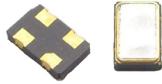

Description

The 3.3V S1633 is a crystal-controlled, low-current, low voltage oscillator providing precise rise and fall times to drive high performance applications. The miniature, low profile leadless ceramic package has gold-plated contact pads, ideal for today's pick-and-place SMT environments. These oscillators are contained in a rugged, subcompact 3.2x5mm package ideal for high density applications requiring tight frequency stability over a range of operating conditions.

Applications & Features

- Miniature, 1.3mm high ceramic package ideal for SMT applications
- 3.3V operation
- Extended frequency range and low jitter for a variety of networking, computing and communications applications requiring compact size or low power
- Low-power standby function included
- Perfect for high density, low power switches, routers, base stations, and storage devices
- Ideal for 802.11 applications
- Anywhere small size, low power, surface mountability are a priority
- Available on tape & reel; 16mm tape, 1000pcs per reel

Frequency Range:	1.8432 MHz to 125 MHz (as specified)
Frequency Stability:	±25ppm, ±50ppm over all conditions; calibration tolerance, operating temperature, rated input (supply) voltage changes, load change, aging*, shock and vibration
Aging*:	1 year @ 25°C average ambient operating temperature
Temperature Range:	
Operating:	-20 to +70°C or -40 to +85°C (as specified)
Storage:	-55 to +125°C
Supply Voltage:	3.3V ±5%
Supply Current:	
Oscillation:	15mA max (1.8432 to 39.9999 MHz) 10mA max (40 to 59.9999 MHz) 40mA max (60 to 79.9999 MHz) 55mA max (80 to 125 MHz)
Stand-by:	0.01mA max (1.8432 to 125 MHz)
Output (LVCMOS / LVTTTL Compatible)	
Symmetry:	45/55% measured @ 50% V _{DD} (-20 to +70°C) 45/55% measured @ 50% V _{DD} (-40 to +85°C, up to 79.9999 MHz) 40/60% measured @ 50% V _{DD} (-40 to +85°C, 80 to 125 MHz)
Rise & Fall Times:	7ns max (1.8432 to 39.9999 MHz) 5ns max (40 to 79.9999 MHz) 3ns max (80 to 125 MHz)
Logic 0:	10% V _{DD} max
Logic 1:	90% V _{DD} min
Load:	15pF max or 10LSTTL
Jitter (1.8432 to 80 MHz):	5ps RMS (1-sigma) max, accumulated in 20,000 adjacent periods 1.5ps RMS (1-sigma) max phase jitter computed in 10 kHz~20 MHz freq. band 50ps peak-to-peak max total jitter, sampled in 100,000 random periods
Jitter (80 to 125 MHz):	3ps RMS (1-sigma) max, accumulated in 20,000 adjacent periods 1ps RMS (1-sigma) max phase jitter computed in 10 kHz~20 MHz freq. band 30ps peak-to-peak max total jitter, sampled in 100,000 random periods
Standby Function (pad 1):	
Oscillation:	V _{IN} ≥ 2.2V or open
Stand-by:	V _{IN} ≤ 0.8V (output is high impedance)
Oscillation Output Delay:	10ms max
Standby Output Delay:	0.1µs max
Internal Pullup Resistance:	50KΩ min
Mechanical:	
Shock:	MIL-STD-883, Method 2002, Condition B
Solderability:	MIL-STD-883, Method 2003
Solvent Resistance:	MIL-STD-202, Method 215
Terminal Strength:	MIL-STD-883, Method 2004, Condition D
Gross Leak:	MIL-STD-883, Method 1014, Condition C
Fine Leak:	MIL-STD-883, Method 1014, Condition A2 (R _I = 2x10 ⁻⁸ atm cc/s)
Environmental:	
Thermal Shock:	MIL-STD-883, Method 1011, Condition A
Moisture Resistance:	MIL-STD-883, Method 1004
Vibration:	MIL-STD-883, Method 2007, Condition A
Resistance to Soldering Heat:	MIL-STD-202, Method 210, Condition I or J

Technical Data

S1633 Series

Package Details

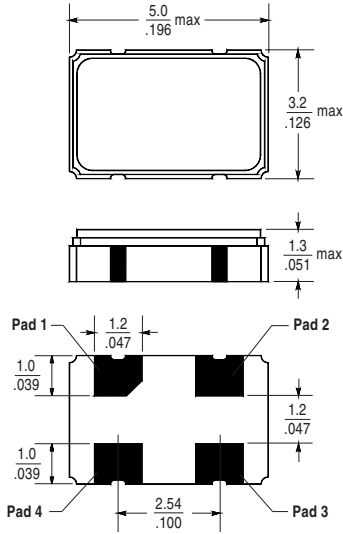

Pad Functions:

Pad 1: En/Disable (Standby) Pad 3: Output
Pad 2: GND Pad 4: VDD

Marking Format (exact location of items may vary)

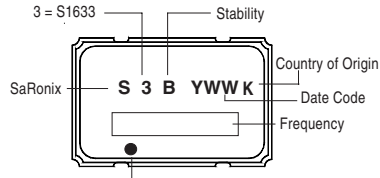

Recommended Land Pattern

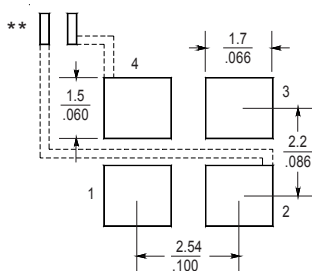

** External high frequency power supply decoupling required.

Scale: None (Dimensions in $\frac{\text{mm}}{\text{inches}}$)

Part Numbering Guide

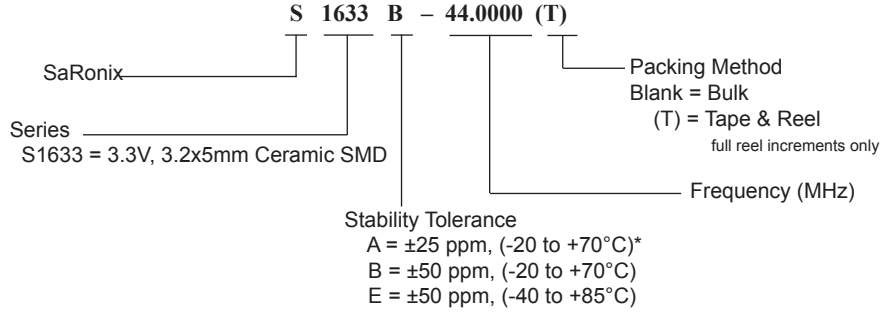

*(Confirm availability by frequency)

Output Waveform

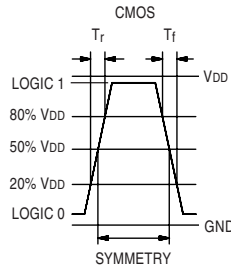

Solder Reflow Guide

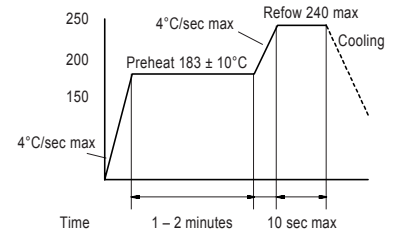

Test Circuit

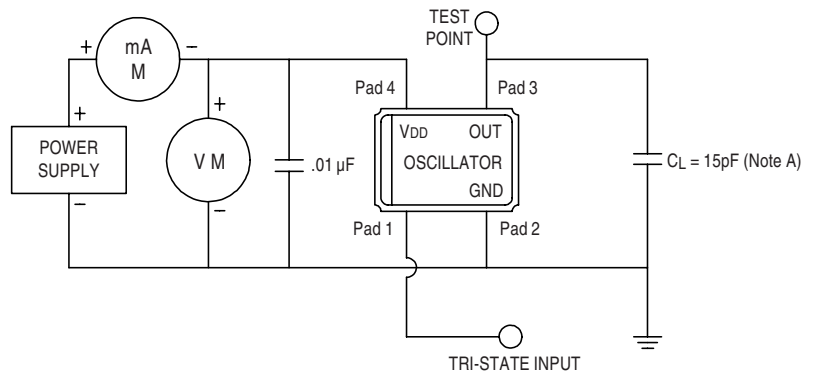

Note A: C_L includes probe and jig capacitance.

*All specifications subject to changes without notice