

**SINGLE N-CHANNEL HIGH SIDE INTELLIGENT POWER DEVICE**

**GENERAL DESCRIPTION**

The μPD166007 device is an N-channel high-side switch with charge pump, current controlled input, diagnostic feedback with load current sense and embedded protection functions.

**FEATURES**

- Built-in charge pump
- Low on-state resistance
- Short-circuit protection
  - Shutdown by short-circuit detection
- Over-temperature protection
  - Shutdown with auto-restart on cooling
- Small multi-chip package: JEDEC 5-pin TO-252

**PACKAGE DRAWING (unit: mm)**

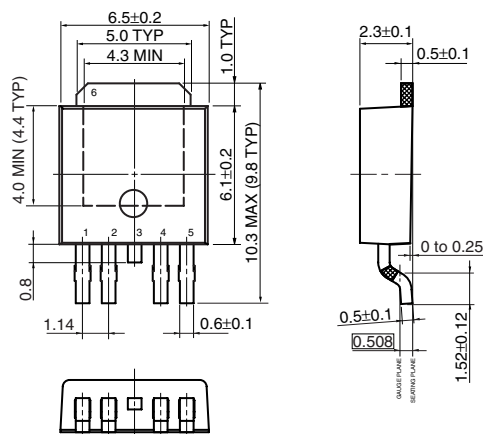

NOTE  
1. No Plating area

<R> (MSL: 3, profile acc. J-STD-20C)

- Built-in diagnostic function
  - Proportional load current sensing
  - Defined fault signal in case of thermal shutdown and/or short circuit shutdown

**<R> ORDERING INFORMATION**

Part Number	Lead plating	Packing	Package
μPD166007T1F-E1-AY <sup>Note</sup>	Sn	Tape 2500 p/reel	5-pin TO-252 (MP-3ZK)

**Note** Pb-free (This product does not contain Pb in the external electrode.)

**<R> QUALITY GRADE**

Part Number	Quality Grade
μPD166007T1F-E1-AY	Special

Please refer to "Quality Grades on NEC Semiconductor Devices" (Document No. C11531E) published by NEC Corporation to know the specification of quality grade on the devices and its recommended applications.

**APPLICATION**

- Light bulb (to 55 W) switching
- Switching of all types of 14 V DC grounded loads, such as inductor, resistor and capacitor
- Replacement for fuse and relay

The information in this document is subject to change without notice. Before using this document, please confirm that this is the latest version.  
Not all products and/or types are available in every country. Please check with an NEC Electronics sales representative for availability and additional information.

<R> BLOCK DIAGRAM

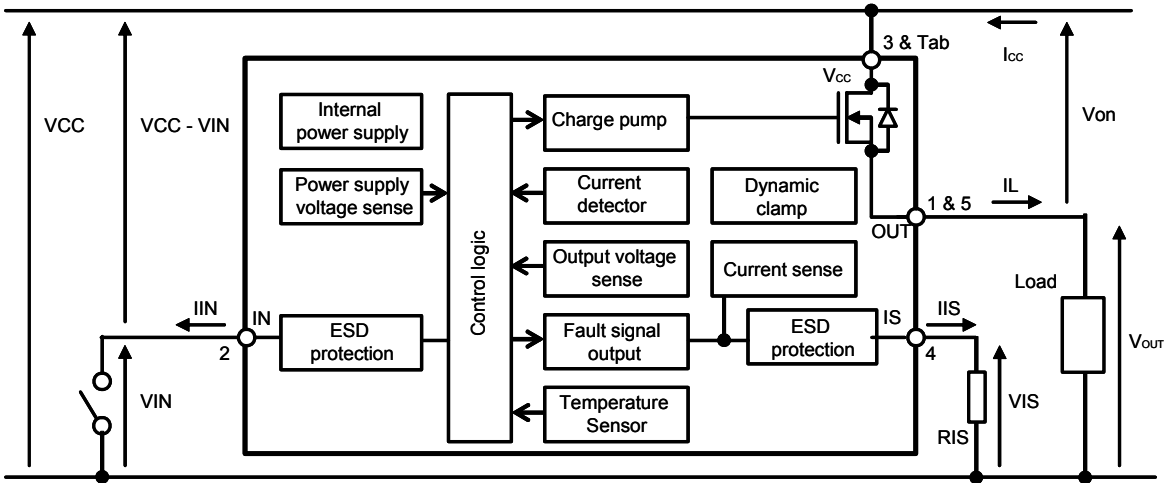

PIN CONFIGURATION

Pin No.	Terminal Name	Function
1	OUT	Output to load: pin 1 and 5 must be externally shorted.
2	IN	Input; activates the power switch, if shorted to ground.
3&Tab	V <sub>CC</sub>	Supply Voltage: tab and pin 3 are internally shorted.
4	I <sub>S</sub>	Sense Output: diagnostic feedback <sup>Note</sup>
5	OUT	Output to load: pin 1 and 5 must be externally shorted.

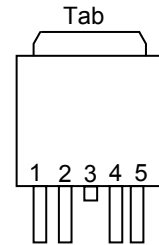

**Note** If current sense and diagnostic features are not used, IS terminal has to be connected to GND via resistor.

**ABSOLUTE MAXIMUM RATING (Ta = 25°C, unless otherwise specified)**

Parameter	Symbol	Test Conditions	Rating	Unit	
V <sub>CC</sub> voltage	V <sub>CC1</sub>		28	V	
V <sub>CC</sub> voltage for full short circuit protection	V <sub>CC2</sub>		18	V	
V <sub>CC</sub> voltage (Load Dump)	V <sub>CC3</sub>	R <sub>I</sub> = 1 Ω, R <sub>L</sub> = 1.5 Ω, t <sub>d</sub> = 400 ms, R <sub>IS</sub> = 1 kΩ, I <sub>N</sub> = low or high	36	V	
Load current	I <sub>L</sub>	DC, T <sub>C</sub> = 25°C	30	A	
Load current (short circuit current)	I <sub>L(SC)</sub>		Self Limited	A	
Power dissipation	P <sub>D</sub>	T <sub>C</sub> = 25°C	59	W	
Channel temperature	T <sub>ch</sub>		-40 to +150	°C	
Storage temperature	T <sub>stg</sub>		-55 to +150	°C	
Electric discharge capability (Human Body Model)	V <sub>ESD</sub>	R = 1.5 kΩ, C = 100pF	IN, IS	±2.0	kV
			OUT	±4.0	kV
Voltage of IN pin (DC)	V <sub>IN</sub>	V <sub>CC</sub> = 14 V	V <sub>CC</sub> +14 V, V <sub>CC</sub> -28 V	V	
Voltage of IS pin (DC)	V <sub>IS</sub>	V <sub>CC</sub> = 14 V	V <sub>CC</sub> +14 V, V <sub>CC</sub> -28 V	V	

**RECOMMENDED OPERATING CONDITIONS**

Parameter	Symbol	Test Conditions	Min.	Typ.	Max.	Unit
Power supply voltage	V <sub>CC</sub>	T <sub>ch</sub> = -40 to 150°C	8		18	V

**THERMAL CHARACTERISTICS**

Parameter	Symbol	Test Conditions	Min.	Typ.	Max.	Unit
Thermal Resistance	R <sub>th(ch-a)</sub>	Device on 50 mm x 50 mm x 1.5 mm epoxy PCB FR4 with 6 cm <sup>2</sup> of 70 μm copper area		45	55	°C/W

**ELECTRICAL CHARACTERISTICS (V<sub>CC</sub> = 12 V, T<sub>ch</sub> = 25°C, unless otherwise specified)**

Parameter	Symbol	Test Conditions	Min.	Typ.	Max.	Unit
Required current capability of Input switch	I <sub>IH</sub>	T <sub>ch</sub> = -40 to 150°C		0.7	2.2	mA
Input current for turn-off	I <sub>IL</sub>				10	μA
Standby Current	I <sub>CC(off)</sub>	I <sub>in</sub> = 0 A	T <sub>ch</sub> = 25°C	4	6	μA
			T <sub>ch</sub> = -40 to 150°C	4	15	μA
On State Resistance	R <sub>on</sub>	I <sub>L</sub> = 7.5 A	T <sub>ch</sub> = 25°C	8	10	mΩ
			T <sub>ch</sub> = 150°C	14	18	
Turn On Time	T <sub>on</sub>	R <sub>L</sub> = 2.2 Ω, T <sub>ch</sub> = -40 to 150°C		200	400	μs
Turn Off Time	T <sub>off</sub>			250	700	μs
Rise time	T <sub>r</sub>	refer to page 15		150	300	μs
Fall time	T <sub>f</sub>			100	500	μs
Slew rate on	dV/dton	25 to 50% V <sub>OUT</sub> , R <sub>L</sub> = 2.2 Ω, T <sub>ch</sub> = -40 to 150°C, refer to page 15		0.2	0.6	V/μs
Slew rate off	-dV/dtoff	50 to 25% V <sub>OUT</sub> , R <sub>L</sub> = 2.2 Ω, T <sub>ch</sub> = -40 to 150°C, refer to page 15		0.2	0.5	V/μs

**PROTECTION FUNCTIONS (V<sub>CC</sub> = 12 V, T<sub>ch</sub> = 25°C, unless otherwise specified)**

Parameter	Symbol	Test Conditions	Min.	Typ.	Max.	Unit	
Output voltage drop at reverse battery condition <b>Note</b>	V <sub>ds(rev)</sub>	V <sub>CC</sub> = -12 V, I <sub>L</sub> = -7.5 A, R <sub>IS</sub> = 1 kΩ	T <sub>ch</sub> = 25°C		0.8	0.84	V
			T <sub>ch</sub> = 150°C		0.6	0.63	V
Short circuit detection current	<b>Note</b> I <sub>L6, 3(SC)</sub>	V <sub>CC</sub> - V <sub>IN</sub> = 6 V, V <sub>on</sub> = 3 V	T <sub>ch</sub> = -40°C		50	120	A
			T <sub>ch</sub> = 25°C		50		
			T <sub>ch</sub> = 150°C	20	45		
	<b>Note</b> I <sub>L6, 6(SC)</sub>	V <sub>CC</sub> - V <sub>IN</sub> = 6 V, V <sub>on</sub> = 6 V	T <sub>ch</sub> = -40°C		35	110	
			T <sub>ch</sub> = 25°C		35		
			T <sub>ch</sub> = 150°C	10	35		
	I <sub>L12, 3(SC)</sub>	V <sub>CC</sub> - V <sub>IN</sub> = 12 V, V <sub>on</sub> = 3 V	T <sub>ch</sub> = -40°C		110	180	
			T <sub>ch</sub> = 25°C	76	105		
			T <sub>ch</sub> = 150°C	50	95		
	<b>Note</b> I <sub>L12, 6(SC)</sub>	V <sub>CC</sub> - V <sub>IN</sub> = 12 V, V <sub>on</sub> = 6 V	T <sub>ch</sub> = -40°C		90	160	
			T <sub>ch</sub> = 25°C		85		
			T <sub>ch</sub> = 150°C	40	80		
	<b>Note</b> I <sub>L12, 12(SC)</sub>	V <sub>CC</sub> - V <sub>IN</sub> = 12 V, V <sub>on</sub> = 12 V	T <sub>ch</sub> = -40°C		55	120	
			T <sub>ch</sub> = 25°C		50		
			T <sub>ch</sub> = 150°C	10	45		
	<b>Note</b> I <sub>L18, 3(SC)</sub>	V <sub>CC</sub> - V <sub>IN</sub> = 18 V, V <sub>on</sub> = 3 V	T <sub>ch</sub> = -40°C		130	200	
			T <sub>ch</sub> = 25°C		125		
			T <sub>ch</sub> = 150°C	60	110		
	<b>Note</b> I <sub>L18, 6(SC)</sub>	V <sub>CC</sub> - V <sub>IN</sub> = 18 V, V <sub>on</sub> = 6 V	T <sub>ch</sub> = -40°C		110	170	
			T <sub>ch</sub> = 25°C		110		
			T <sub>ch</sub> = 150°C	50	100		
	<b>Note</b> I <sub>L18, 12(SC)</sub>	V <sub>CC</sub> - V <sub>IN</sub> = 18 V, V <sub>on</sub> = 12 V	T <sub>ch</sub> = -40°C		75	120	
			T <sub>ch</sub> = 25°C		70		
			T <sub>ch</sub> = 150°C	30	65		
<b>Note</b> I <sub>L18, 18(SC)</sub>	V <sub>CC</sub> - V <sub>IN</sub> = 18 V, V <sub>on</sub> = 18 V	T <sub>ch</sub> = -40°C		50	90		
		T <sub>ch</sub> = 25°C		50			
		T <sub>ch</sub> = 150°C	5	45			
Output clamp voltage (inductive load switch off)	V <sub>on(CL)</sub>	I <sub>L</sub> = 40 mA	30	34	40	V	
Over load detection voltage	V <sub>ON(OvL)</sub>	T <sub>ch</sub> = -40 to 150°C	0.65	1	1.45	V	
Turn-on check delay after input current positive slope	t <sub>d(OC)</sub>	T <sub>ch</sub> = -40 to 150°C	0.8	1.9	3.5	ms	
Thermal shutdown temperature	T <sub>th</sub>		150	175		°C	
Thermal hysteresis	ΔT <sub>th</sub>			10		°C	

**Note** Not subject to production test, specified by design.

**DIAGNOSTIC CHARACTERISTICS (V<sub>CC</sub> = 12 V, T<sub>ch</sub> = 25°C, unless otherwise specified)**

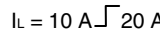
Parameter	Symbol	Test Conditions	Min.	Typ.	Max.	Unit					
Current sense ratio	K <sub>ILIS</sub>	$K_{ILIS} = I_L / I_{IS}$ $V_{IS} < V_{OUT} - 6 V, I_{IS} < I_{IS,lim}$									
							I <sub>L</sub> = 30 A	T <sub>ch</sub> = -40°C	8300	9350	11000
								T <sub>ch</sub> = 25°C	8300	9400	10600
								T <sub>ch</sub> = 150°C	8300	9450	10000
							I <sub>L</sub> = 7.5 A	T <sub>ch</sub> = -40°C	7500	9400	11400
								T <sub>ch</sub> = 25°C	8000	9500	10800
								T <sub>ch</sub> = 150°C	8200	9550	10200
							I <sub>L</sub> = 2.5 A	T <sub>ch</sub> = -40°C	6100	9600	14200
								T <sub>ch</sub> = 25°C	6500	9600	12800
T <sub>ch</sub> = 150°C	7600	9600	11500								
Sense current offset current	I <sub>IS,offset</sub>	V <sub>IN</sub> = 0 V, I <sub>L</sub> = 0 A	0		60	μA					
Sense current under fault condition	I <sub>IS,fault</sub>	Under fault conditions 8 V < V <sub>CC</sub> - V <sub>IS</sub> < 12 V, T <sub>ch</sub> = -40 to 150°C	3.5	6.0	12.0	mA					
Sense current saturation current	I <sub>IS,lim</sub>	V <sub>IS</sub> < V <sub>out</sub> - 6 V, T <sub>ch</sub> = -40 to 150°C	3.5	7.0	12.0	mA					
Fault sense signal delay after short circuit detection <small>Note</small>	t <sub>sdelay(fault)</sub>	T <sub>ch</sub> = -40 to 150°C		2	6	μs					
Sense current leakage current	I <sub>IS(LL)</sub>	I <sub>IN</sub> = 0 A		0.1	0.5	μA					
Current sense settling time after input current positive slope <small>Note</small>	t <sub>son(IS)</sub>	T <sub>ch</sub> = -40 to 150°C			250	1000	μs				
Current sense settling time during on condition <small>Note</small>	T <sub>sic(IS)</sub>							I <sub>L</sub> = 10 A 	50	100	μs

**Note** Not subject to production test, specified by design.

FEATURES DESCRIPTION

Driver Circuit (On-Off Control)

The high-side output is turned on, if the input pin is shorted to ground. The input current is below  $I_{IH}$ . The high-side output is turned off, if the input pin is open or the input current is below  $I_{IL}$ .  $R_{in0}$  is 130 Ω typ. ESD protection diode: 46 V typ.

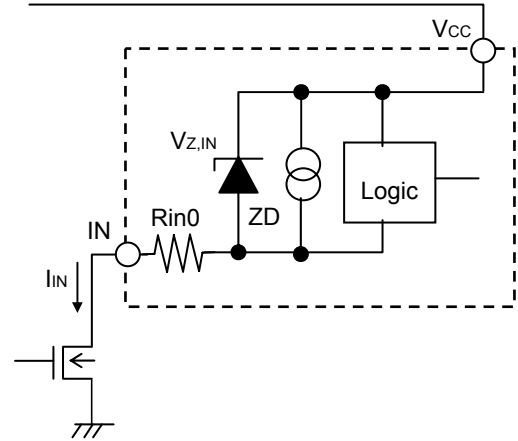
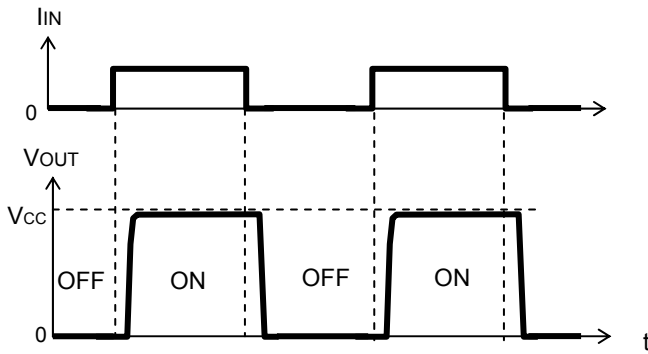

Switching a resistive load

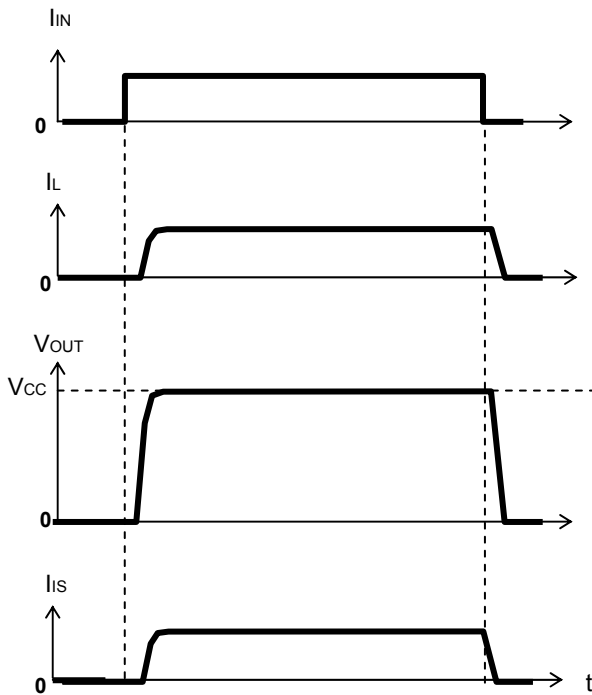

Switching lamps

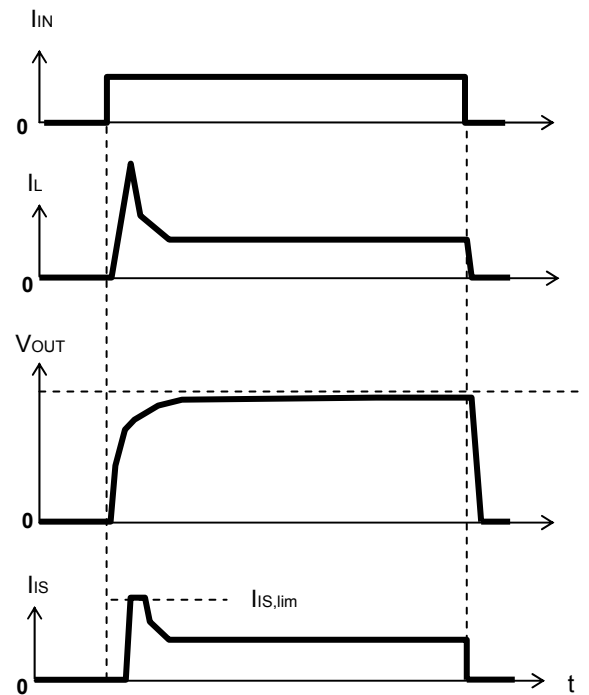

Switching an inductive load

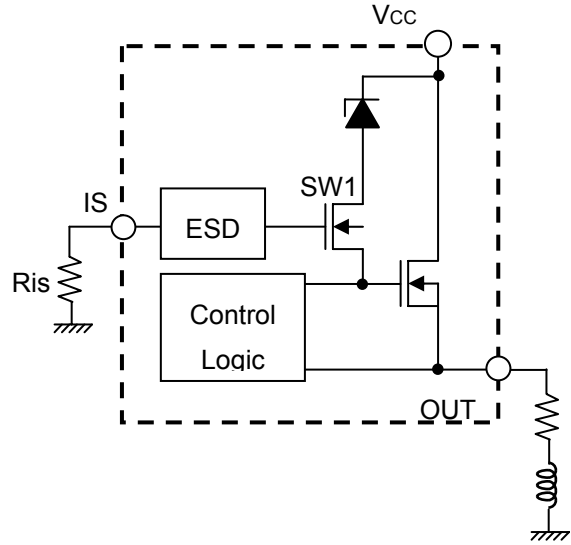
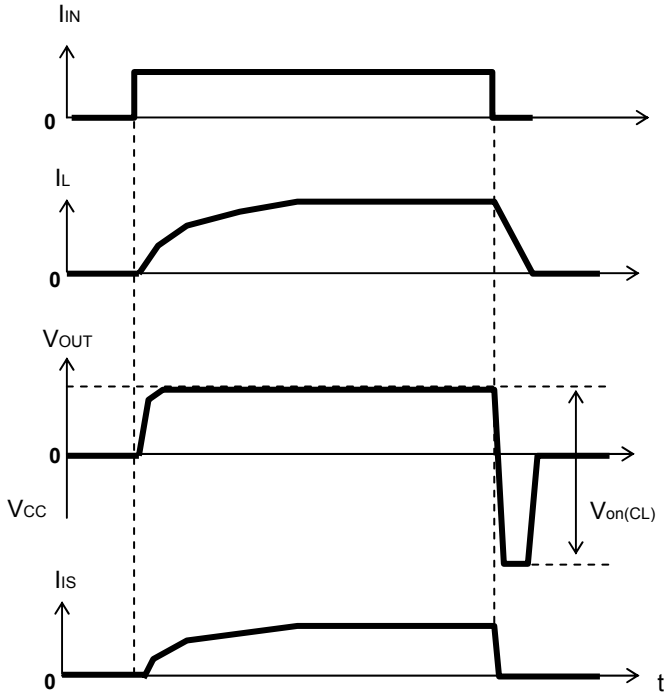

Dynamic clamp operation at inductive load switch off

The dynamic clamp circuit works only when the inductive load is switched off. When the inductive load is switched off, the voltage of  $OUT$  falls below 0 V. The gate voltage of  $SW1$  is then nearly equal to GND because the  $I_S$  terminal is connected to GND via an external resistor. Next, the voltage at the source of  $SW1$  (= gate of output MOS) falls below the GND voltage.  $SW1$  is turned on, and the clamp diode is connected to the gate of the output MOS, activating the dynamic clamp circuit.

When the over-voltage is applied to  $V_{CC}$ , the gate voltage and source voltage of  $SW1$  are both nearly equal to GND.  $SW1$  is not turned on, the clamp diode is not connected to the gate of the output MOS, and the dynamic clamp circuit is not activated.

**Short circuit protection**

Case 1: IN pin is shorted to ground in an overload condition, which includes a short circuit condition.

The device shuts down automatically when either or both of following conditions (a, b) is detected. The sense current is fixed at  $I_{IS, fault}$ . Shutdown is latched until the next reset via input.

- (a)  $I_L > I_{L(sc)}$
- (b)  $V_{on} > V_{on(OvL)}$  after  $t_{d(OC)}$

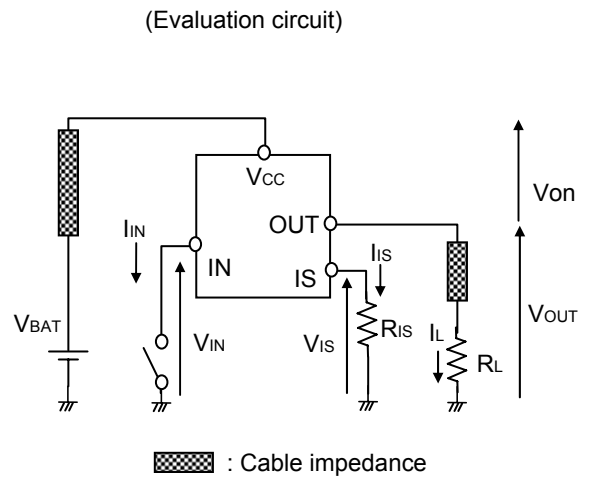
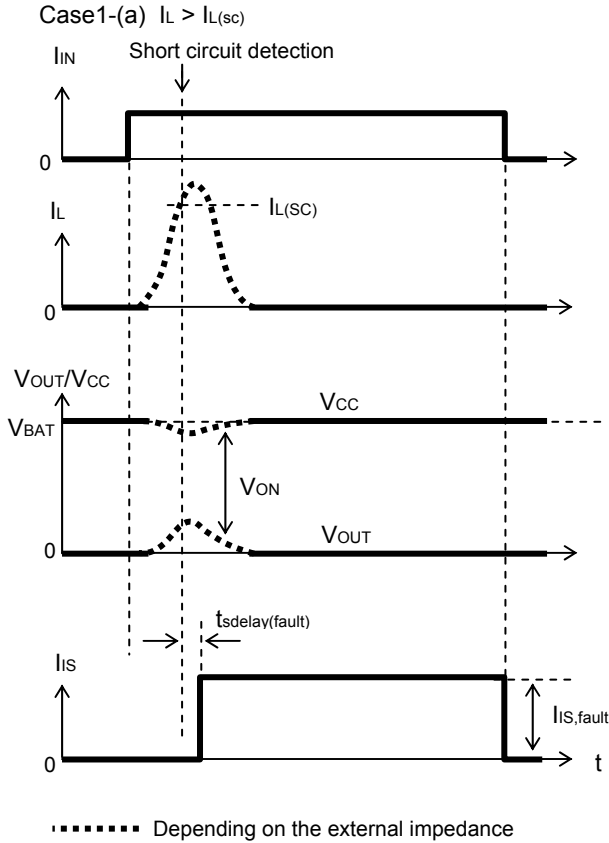

$t_{sdelay(fault)}$ : Fault sense signal delay after short circuit detection  
 $I_{L(sc)}$ : Short circuit detection current

**Typical Short circuit detection current characteristics**

The short circuit detection current changes according  $V_{CC}$  voltage and  $V_{on}$  voltage for the purpose of to be strength of the robustness under short circuit condition.

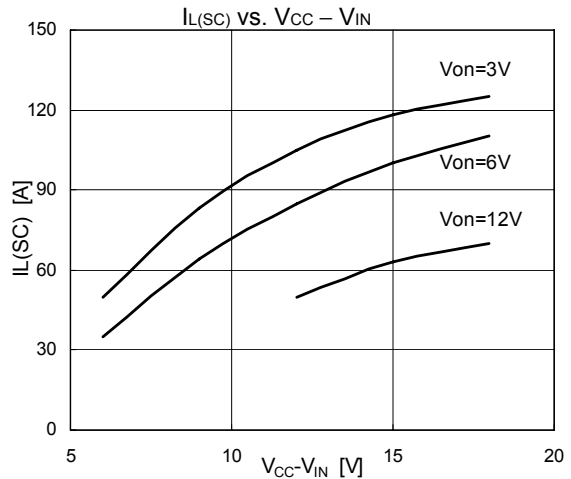
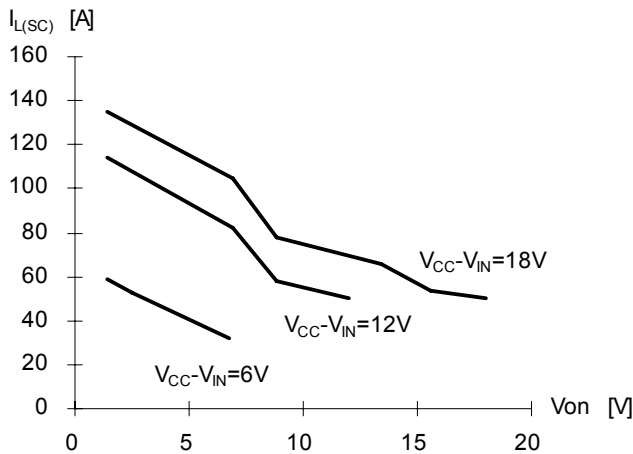

Case1-(b)  $V_{on} > V_{on(OvL)}$  after  $t_{d(oc)}$

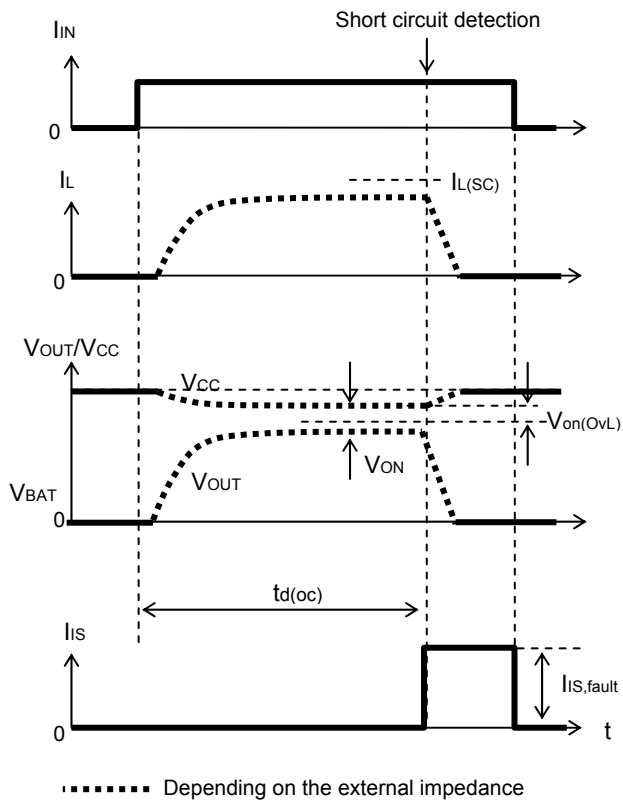

(Evaluation circuit)

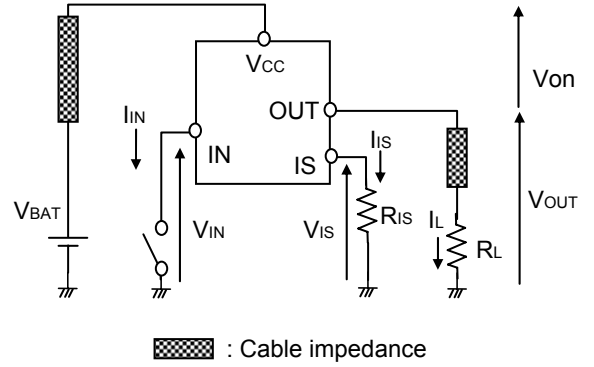

$t_{d(oc)}$ : Turn-on check delay after input current positive slope

Case 2: Short circuit during on-condition

The device shuts down automatically when either or both of following conditions (a, b) is detected. The sense current is fixed at  $I_{IS, fault}$ . Shutdown is latched until the next reset via input.

- (a)  $I_L > I_{L(sc)}$
- (b)  $V_{on} > V_{on(OVL)}$  after  $t_{d(oc)}$

Case2-(a)  $I_L > I_{L(sc)}$

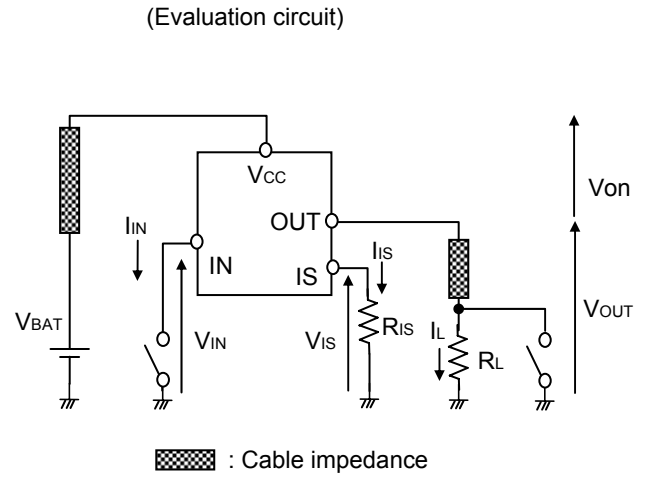
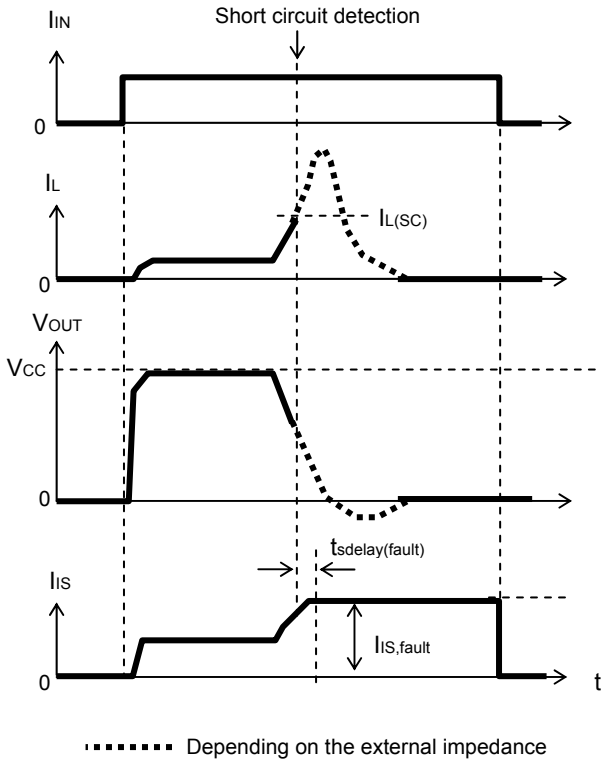

$t_{sdelay(fault)}$ : Fault sense signal delay after short circuit detection  
 $I_{L(SC)}$ : short circuit detection current



**Over-temperature protection**

The output is switched off if over-temperature is detected. The device switches on again after it cools down.

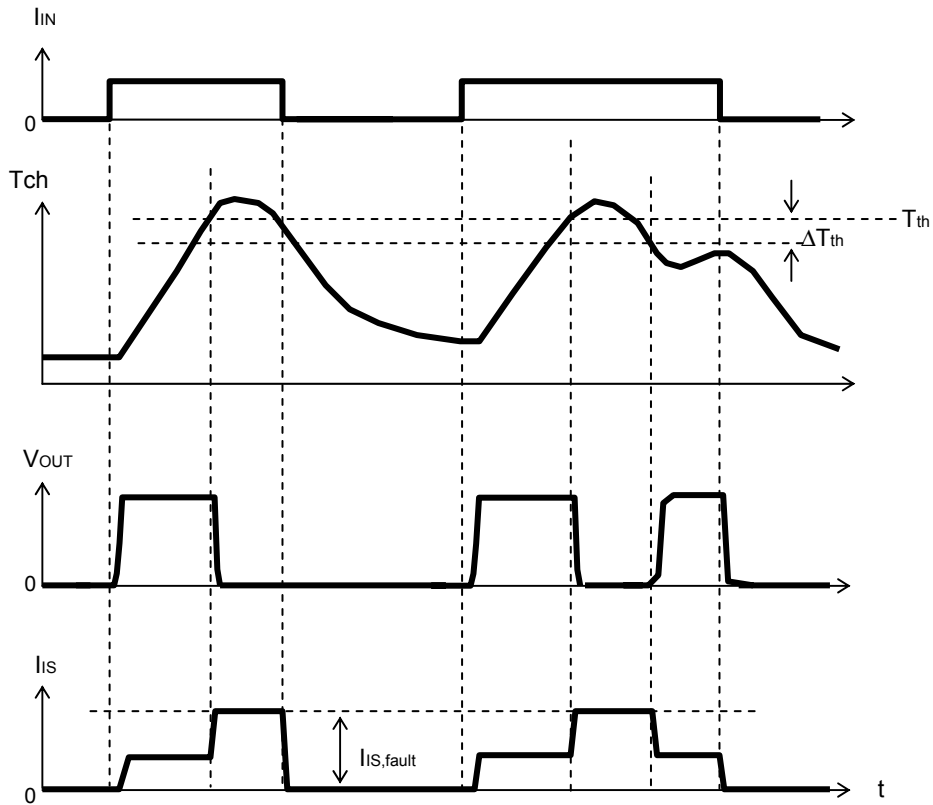

**Power dissipation under reverse battery condition**

In the case of a reverse battery condition, the intrinsic body diode causes power dissipation. Additional power is dissipated by the internal resistor. The following is the formula for estimation of total power dissipation Pd(rev) in a reverse battery condition.

$$P_{d(rev)} = V_{ds(rev)} \times I_L + (V_{CC} - V_f - I_{in(rev)} \times R_{in}) \times I_{in(rev)} + (V_{CC} - I_{is(rev)} \times R_{is}) \times I_{is(rev)}$$

$$I_{in(rev)} = (V_{CC} - (V_f + V_{f,IN})) / (R_{in0} + R_{in})$$

$$I_{is(rev)} = (V_{CC} - V_{f,IS}) / (R_{is0} + R_{is})$$

- V<sub>f,IN</sub>: Forward voltage of V<sub>Z,IN</sub>
- V<sub>f,IS</sub>: Forward voltage of V<sub>Z,IS</sub>
- V<sub>f</sub>: Forward voltage of parasitic diode of external input switch

The reverse current through the intrinsic body diode has to be limited by the connected load. The current through sense pin IN is limited by R<sub>in0</sub> 130 Ω typ.. (Please refer to Current sense output). The current through input pin IS is limited by R<sub>is0</sub> 130 Ω typ. and external R<sub>is</sub>. (Please refer to Driver Circuit (On-Off Control)).

**Device behavior at low voltage condition**

If the voltage supply goes down, the device cannot keep a fully ON state under 4.6 V(typ.), and Von voltage is going to increase. Then, if Von voltage goes over Von(OvL), the device shuts down the output. Shutdown is latched until the next reset via input. Shutdown does not work during td(oc) after input is active. VON(OvL) goes down under 4.6 V.

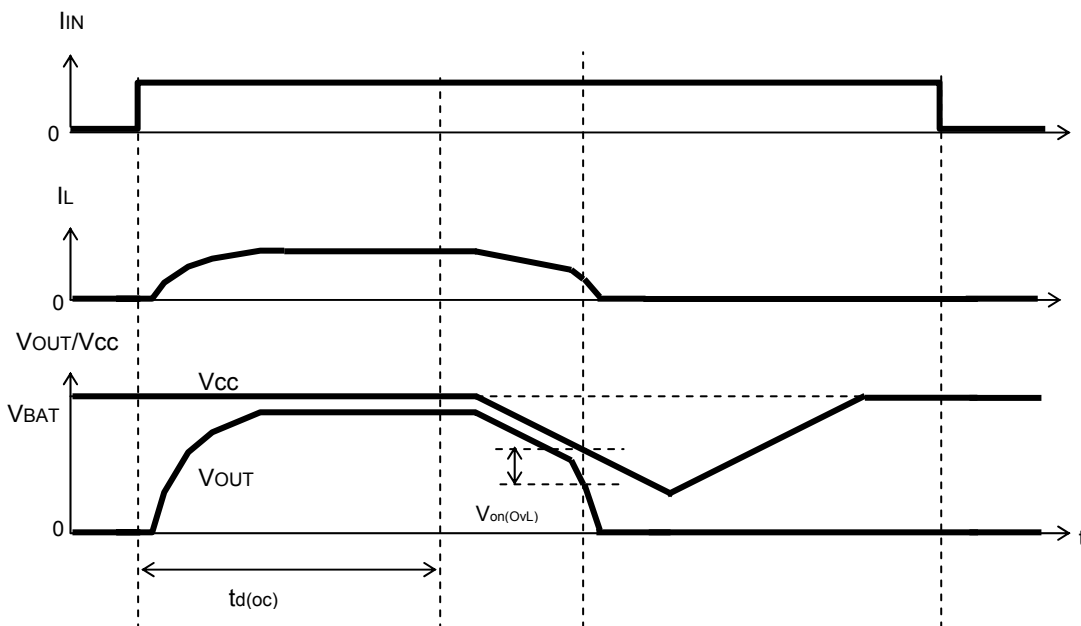

**Over load detection voltage characteristics under low voltage supply condition**

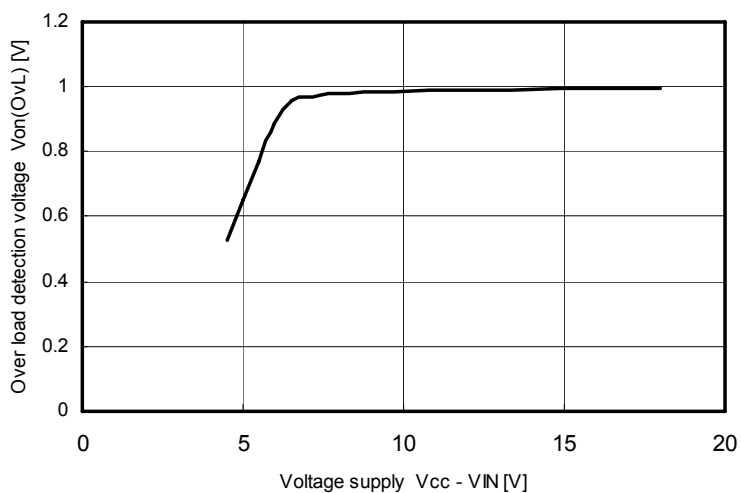

**Current sense output**

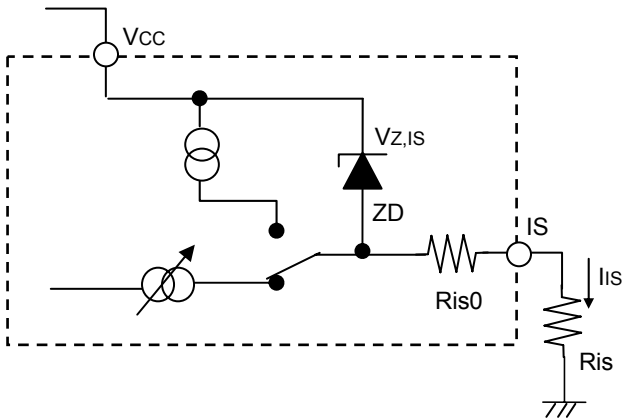

Ris0 is 130 Ω typ.  $V_{z,IS} = 46\text{ V (typ.)}$ ,  $R_{IS} = 1\text{ k}\Omega$  nominal. IS can be only driven by the internal circuit as long as  $V_{IS} < V_{out} - 6\text{ V}$ . Ris should be less than 20 kΩ for any application. Even If current sense and diagnostic features are not used, Ris has to be connected.

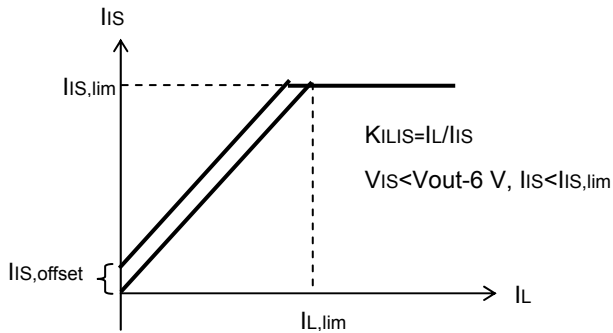

**Current sense ratio**

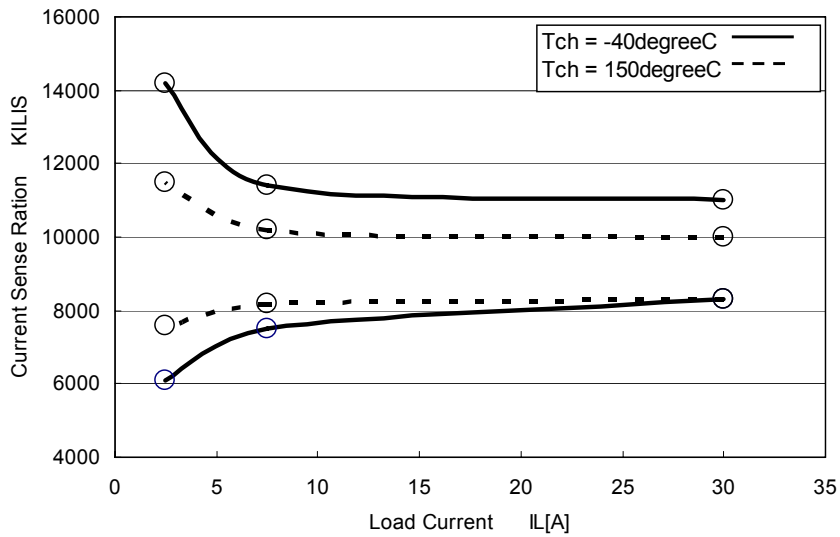

Measurement condition

Switching waveform of OUT Terminal

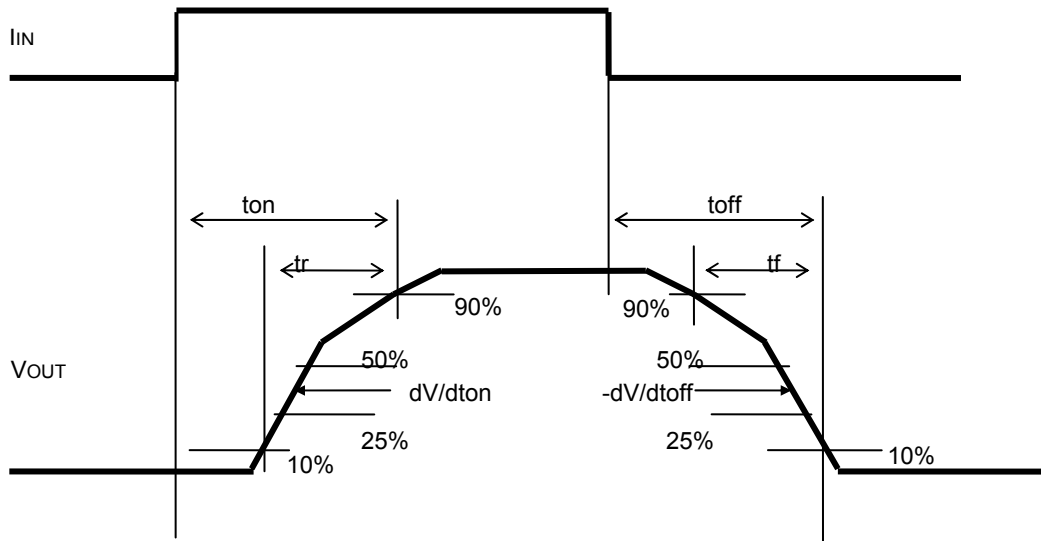

Switching waveform of IS terminal

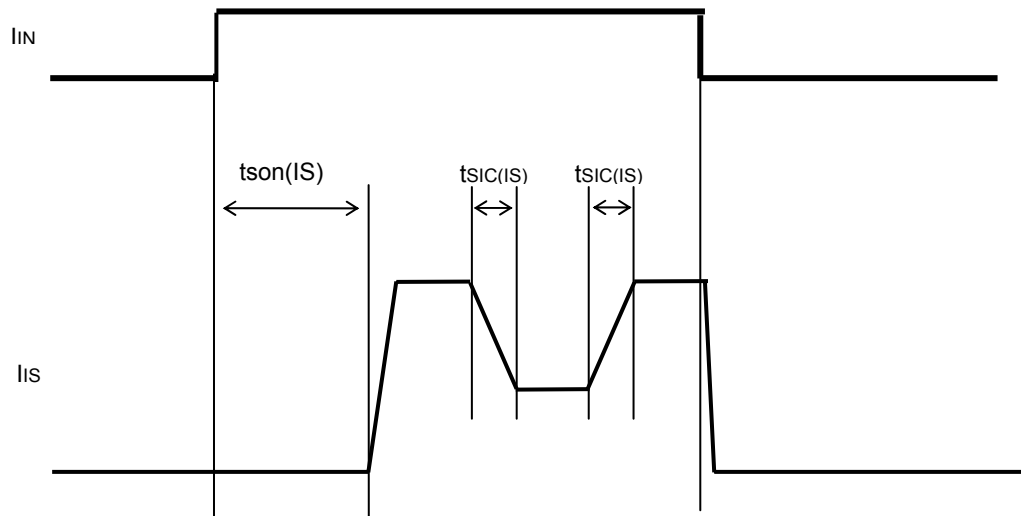

Truth table

Input Current	State	Output	Sense Current
L	-	OFF	$I_{S(LL)}$
H	Normal Operation	ON	$I_{L/KILIS}$
	Over-temperature or Short circuit	OFF	$I_{S, fault}$
	Open Load	ON	$I_{S, offset}$

Application example in principle

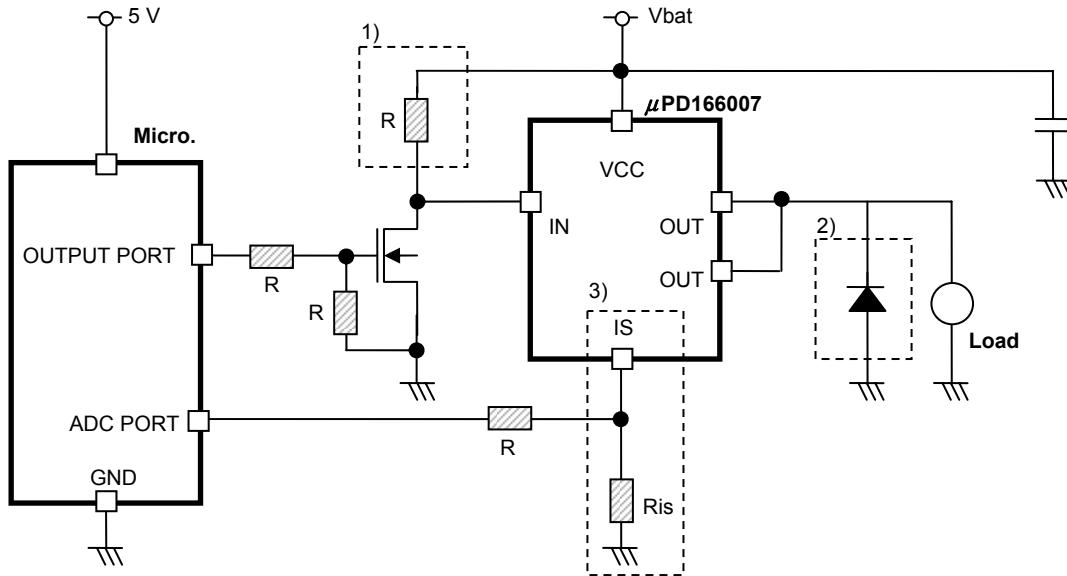

- 1) In order to prevent leakage current through at IN terminal via PCB, it is recommended to pull up the IN terminal to VCC using around 1 to 10 kΩ (approx.) resistor.
- 2) If output current is over destruction current characteristics for inductive load at a single off, it must be connected through an external component for protection purpose.
- 3) If current sense and diagnostic features are not used, IS terminal has to be connected to GND via resistor.

TYPICAL CHARACTERISTICS

REQUIRED CURRENT CAPABILITY OF INPUT SWITCH VS. AMBIENT TEMPERATURE

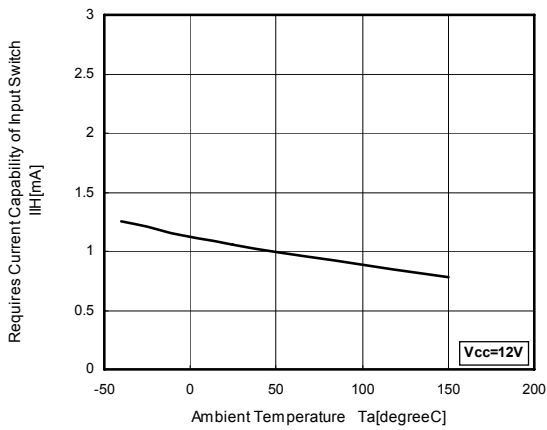

INPUT CURRENT FOR TURN OFF VS. AMBIENT TEMPERATURE

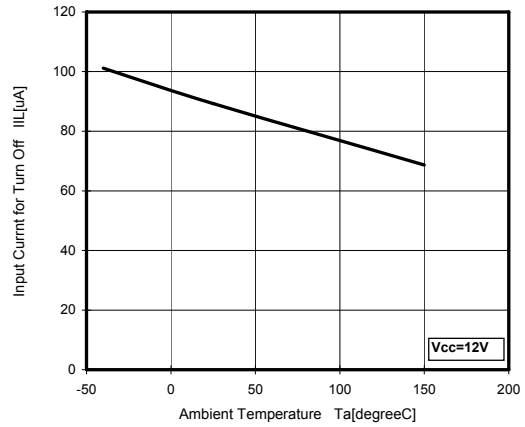

STANDBY CURRENT VS. AMBIENT TEMPERATURE

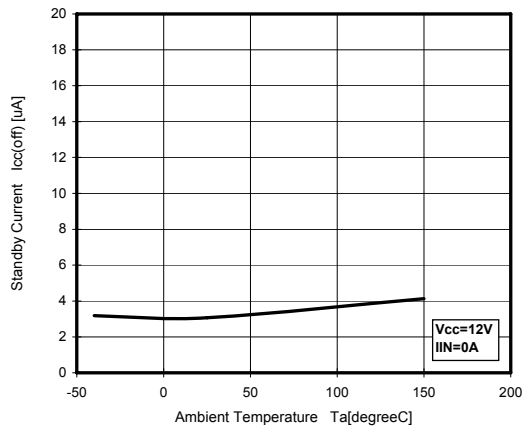

TURN ON TIME VS. AMBIENT TEMPERATURE

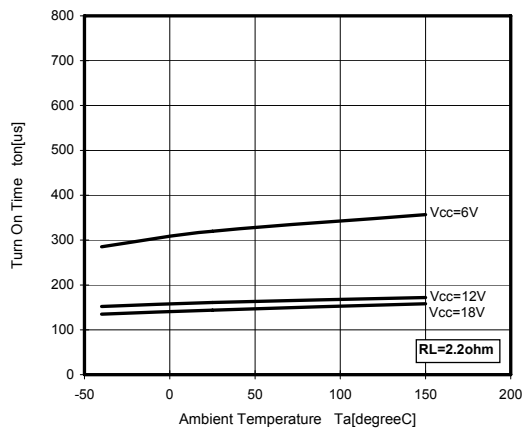

TURN OFF TIME VS. AMBIENT TEMPERATURE

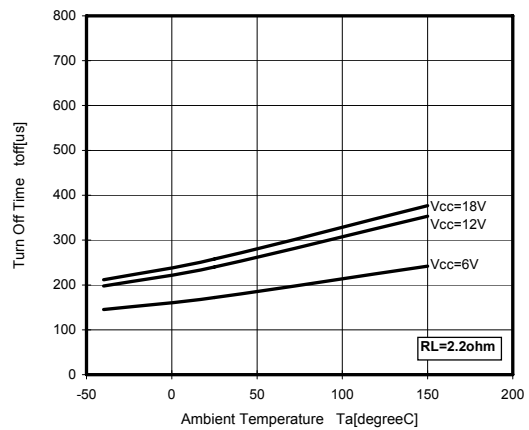

RISE TIME VS. AMBIENT TEMPERATURE

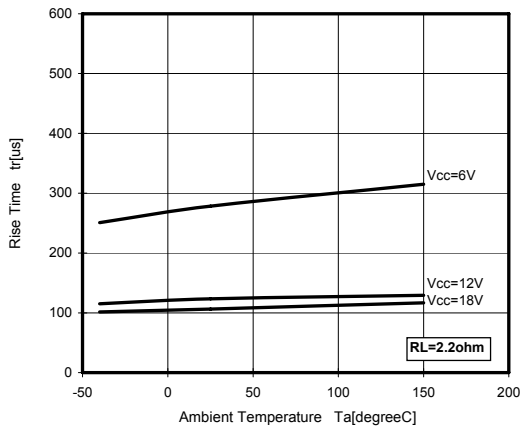

FALL TIME VS. AMBIENT TEMPERATURE

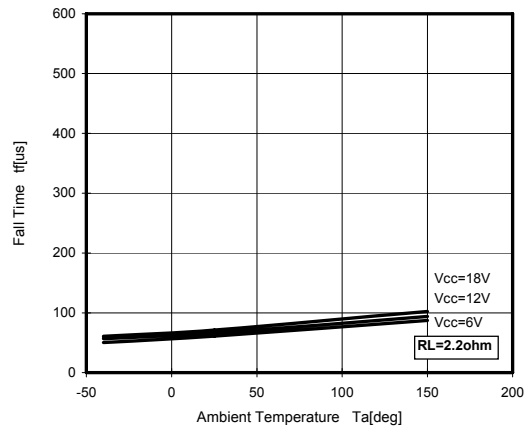

OUTPUT CLAMP VOLTAGE (INDUCTIVE LOAD SWITCH OFF) VS. AMBIENT TEMPERATURE

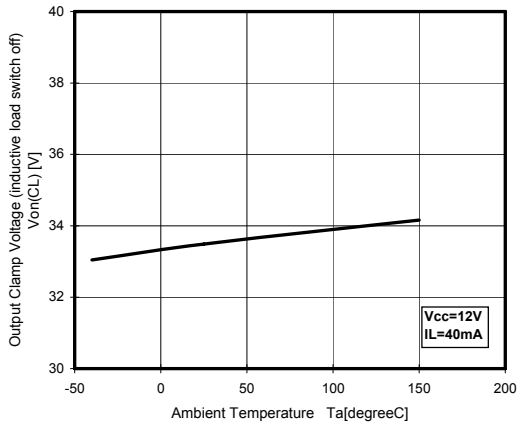

SENSE CURRENT OFFSET CURRENT VS. AMBIENT TEMPERATURE

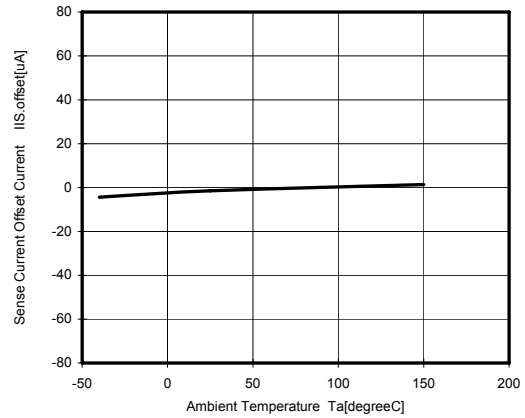

SENSE CURRENT LEAKAGE CURRENT VS. AMBIENT TEMPERATURE

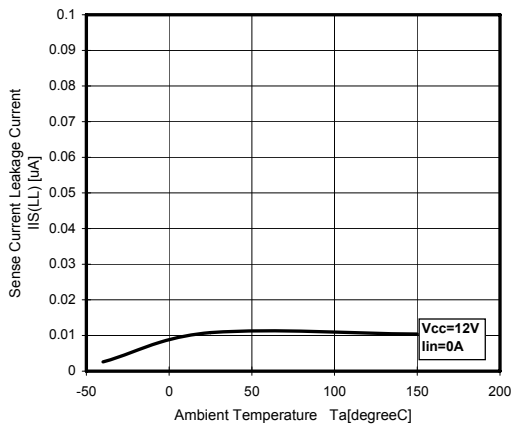

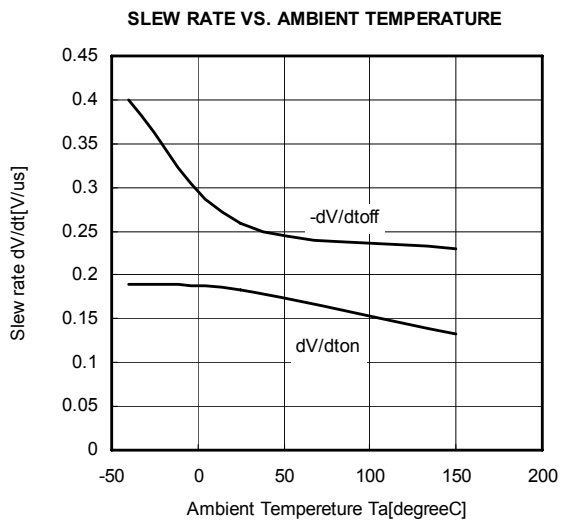
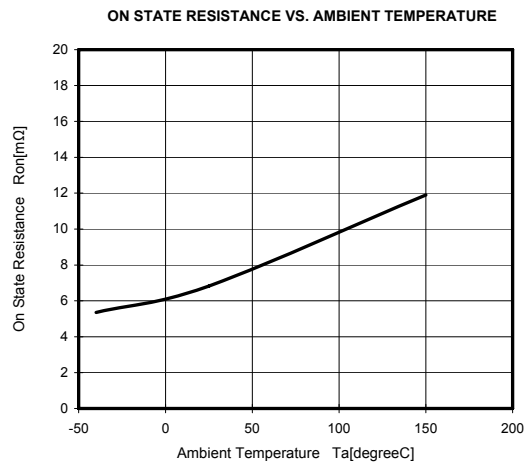
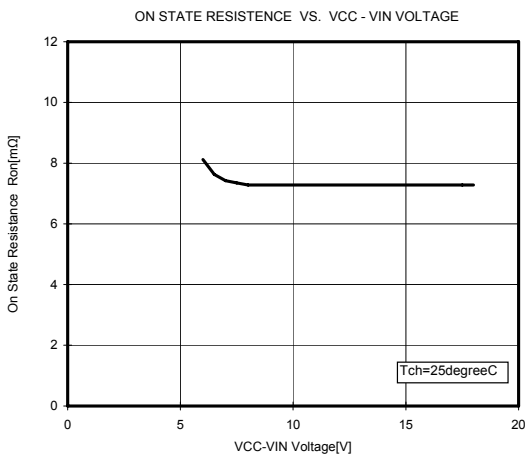
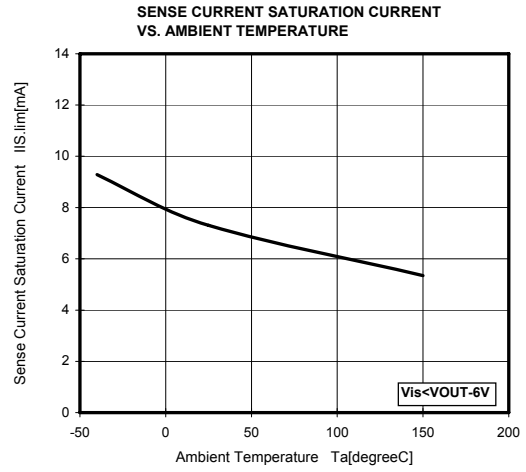
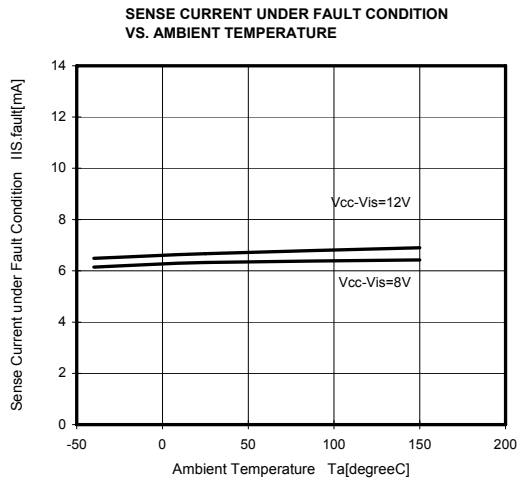

THERMAL CHARACTERISTICS

TRANSIENT THERMAL RESISTANCE vs. PULSE WIDTH

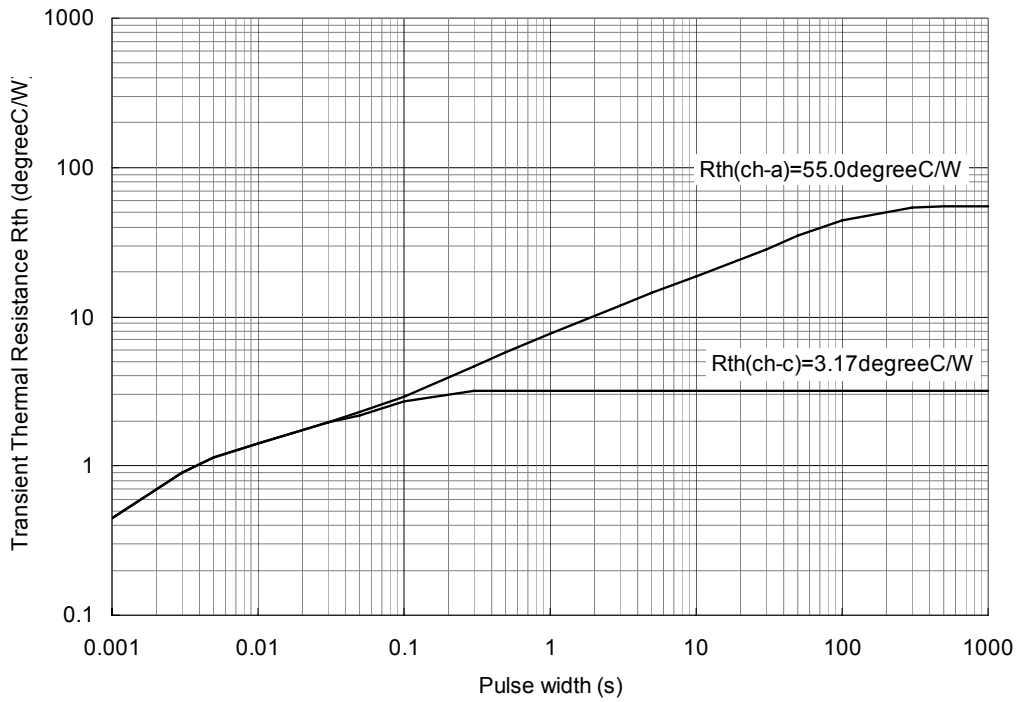

<R> MAXIMUM ALLOWABLE LOAD INDUCTANCE FOR A SINGLE SWITCH OFF

INDUCTIVE LOAD SWITCH-OFF ENERGY DISSIPATION FOR A SINGLE PULSE

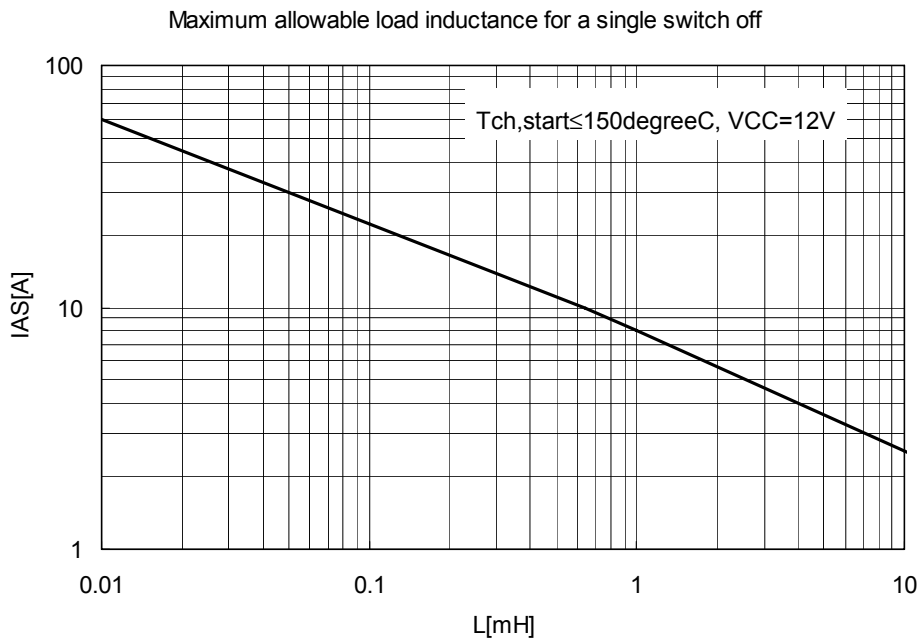

The energy dissipation for an inductive load switch-off single pulse in device (EAS1) is estimated by the following formula as \$R\_L = 0 \Omega\$.

$$EAS1 = \frac{1}{2} \cdot I^2 \cdot L \left( \frac{V_{on}(CL)}{V_{on}(CL) - V_{CC}} \right)$$

<R> **TAPING INFORMATION**

This is one type (E1) of direction of the device in the career tape.

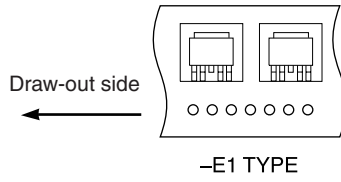

<R> **MARKING INFORMATION**

This figure indicates the marking items and arrangement. However, details of the letterform, the size and the position aren't indicated.

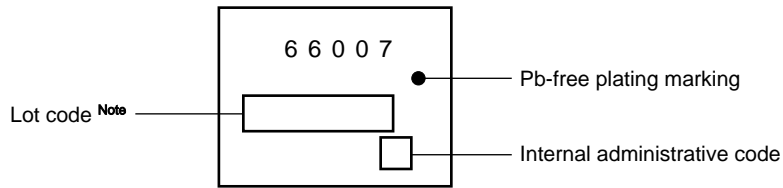

**Note** Composition of the lot code

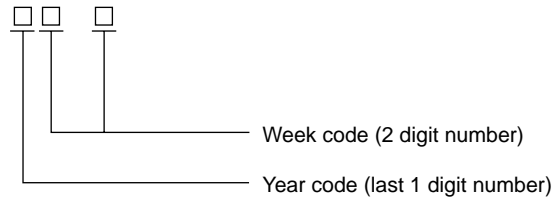

**REVISION HISTORY**

Revision	Major changes since last version	Page
1 <sup>st</sup> edition	Released 1 <sup>st</sup> edition November 2006	
2 <sup>nd</sup> edition	Released 2 <sup>nd</sup> edition April 2007	
	Revised ton, tr characteristics	3
	Add dV/dton, -dV/dtoff characteristics	3
	Add V <sub>ON(OVL)</sub> characteristics	4
	Add t <sub>ai(OC)</sub> characteristics	4
	Add explanation device behavior at switching a inductive load	7
	Add Short circuit protection Case 1-(b)	9
	Add Short circuit protection Case 2-(b)	11
	Add explanation device behavior at low voltage condition	13
	Revised Measurement condition waveform	15
	Revised application example in principle	16
	Add maximum allowable load inductance for a single switch off	20
3 <sup>rd</sup> edition	Released 3 <sup>rd</sup> edition December 2008	
	Add description MSL to Features, revised Ordering information	1
	Revised Block diagram	2
	Revised Maximum allowable load inductance for a single switch off graph	20
	Add Taping information, Marking information	21

## NOTES FOR CMOS DEVICES

**① VOLTAGE APPLICATION WAVEFORM AT INPUT PIN**

Waveform distortion due to input noise or a reflected wave may cause malfunction. If the input of the CMOS device stays in the area between  $V_{IL}$  (MAX) and  $V_{IH}$  (MIN) due to noise, etc., the device may malfunction. Take care to prevent chattering noise from entering the device when the input level is fixed, and also in the transition period when the input level passes through the area between  $V_{IL}$  (MAX) and  $V_{IH}$  (MIN).

**② HANDLING OF UNUSED INPUT PINS**

Unconnected CMOS device inputs can be cause of malfunction. If an input pin is unconnected, it is possible that an internal input level may be generated due to noise, etc., causing malfunction. CMOS devices behave differently than Bipolar or NMOS devices. Input levels of CMOS devices must be fixed high or low by using pull-up or pull-down circuitry. Each unused pin should be connected to  $V_{DD}$  or GND via a resistor if there is a possibility that it will be an output pin. All handling related to unused pins must be judged separately for each device and according to related specifications governing the device.

**③ PRECAUTION AGAINST ESD**

A strong electric field, when exposed to a MOS device, can cause destruction of the gate oxide and ultimately degrade the device operation. Steps must be taken to stop generation of static electricity as much as possible, and quickly dissipate it when it has occurred. Environmental control must be adequate. When it is dry, a humidifier should be used. It is recommended to avoid using insulators that easily build up static electricity. Semiconductor devices must be stored and transported in an anti-static container, static shielding bag or conductive material. All test and measurement tools including work benches and floors should be grounded. The operator should be grounded using a wrist strap. Semiconductor devices must not be touched with bare hands. Similar precautions need to be taken for PW boards with mounted semiconductor devices.

**④ STATUS BEFORE INITIALIZATION**

Power-on does not necessarily define the initial status of a MOS device. Immediately after the power source is turned ON, devices with reset functions have not yet been initialized. Hence, power-on does not guarantee output pin levels, I/O settings or contents of registers. A device is not initialized until the reset signal is received. A reset operation must be executed immediately after power-on for devices with reset functions.

**⑤ POWER ON/OFF SEQUENCE**

In the case of a device that uses different power supplies for the internal operation and external interface, as a rule, switch on the external power supply after switching on the internal power supply. When switching the power supply off, as a rule, switch off the external power supply and then the internal power supply. Use of the reverse power on/off sequences may result in the application of an overvoltage to the internal elements of the device, causing malfunction and degradation of internal elements due to the passage of an abnormal current.

The correct power on/off sequence must be judged separately for each device and according to related specifications governing the device.

**⑥ INPUT OF SIGNAL DURING POWER OFF STATE**

Do not input signals or an I/O pull-up power supply while the device is not powered. The current injection that results from input of such a signal or I/O pull-up power supply may cause malfunction and the abnormal current that passes in the device at this time may cause degradation of internal elements. Input of signals during the power off state must be judged separately for each device and according to related specifications governing the device.

- **The information in this document is current as of December, 2008. The information is subject to change without notice. For actual design-in, refer to the latest publications of NEC Electronics data sheets or data books, etc., for the most up-to-date specifications of NEC Electronics products. Not all products and/or types are available in every country. Please check with an NEC Electronics sales representative for availability and additional information.**
- No part of this document may be copied or reproduced in any form or by any means without the prior written consent of NEC Electronics. NEC Electronics assumes no responsibility for any errors that may appear in this document.
- NEC Electronics does not assume any liability for infringement of patents, copyrights or other intellectual property rights of third parties by or arising from the use of NEC Electronics products listed in this document or any other liability arising from the use of such products. No license, express, implied or otherwise, is granted under any patents, copyrights or other intellectual property rights of NEC Electronics or others.
- Descriptions of circuits, software and other related information in this document are provided for illustrative purposes in semiconductor product operation and application examples. The incorporation of these circuits, software and information in the design of a customer's equipment shall be done under the full responsibility of the customer. NEC Electronics assumes no responsibility for any losses incurred by customers or third parties arising from the use of these circuits, software and information.
- While NEC Electronics endeavors to enhance the quality, reliability and safety of NEC Electronics products, customers agree and acknowledge that the possibility of defects thereof cannot be eliminated entirely. To minimize risks of damage to property or injury (including death) to persons arising from defects in NEC Electronics products, customers must incorporate sufficient safety measures in their design, such as redundancy, fire-containment and anti-failure features.
- NEC Electronics products are classified into the following three quality grades: "Standard", "Special" and "Specific".

The "Specific" quality grade applies only to NEC Electronics products developed based on a customer-designated "quality assurance program" for a specific application. The recommended applications of an NEC Electronics product depend on its quality grade, as indicated below. Customers must check the quality grade of each NEC Electronics product before using it in a particular application.

"Standard": Computers, office equipment, communications equipment, test and measurement equipment, audio and visual equipment, home electronic appliances, machine tools, personal electronic equipment and industrial robots.

"Special": Transportation equipment (automobiles, trains, ships, etc.), traffic control systems, anti-disaster systems, anti-crime systems, safety equipment and medical equipment (not specifically designed for life support).

"Specific": Aircraft, aerospace equipment, submersible repeaters, nuclear reactor control systems, life support systems and medical equipment for life support, etc.

The quality grade of NEC Electronics products is "Standard" unless otherwise expressly specified in NEC Electronics data sheets or data books, etc. If customers wish to use NEC Electronics products in applications not intended by NEC Electronics, they must contact an NEC Electronics sales representative in advance to determine NEC Electronics' willingness to support a given application.

(Note)

- (1) "NEC Electronics" as used in this statement means NEC Electronics Corporation and also includes its majority-owned subsidiaries.
- (2) "NEC Electronics products" means any product developed or manufactured by or for NEC Electronics (as defined above).