

Description

Description

The M16C/62N group of single-chip microcomputers are built using the high-performance silicon gate CMOS process using a M16C/60 Series CPU core and are packaged in a 100-pin plastic molded QFP. These single-chip microcomputers operate using sophisticated instructions featuring a high level of instruction efficiency. With 1M bytes of address space, low voltage (2.4V(mask ROM version is 2.2V) to 3.6V), they are capable of executing instructions at high speed. They also feature a built-in multiplier and DMAC, making them ideal for controlling office, communications, industrial equipment, and other high-speed processing applications.

The M16C/62N group includes a wide range of products with different internal memory types and sizes and various package types.

Features

- Memory capacity ROM (See Figure 1.1.4. ROM Expansion)
RAM 10K to 20K bytes
- Shortest instruction execution time 62.5ns (f(XIN)=16MHz, VCC=3.0V to 3.6V)
142.9ns (f(XIN)=7MHz, VCC=2.4V to 3.6V without software wait)
- Supply voltage 3.0V to 3.6V (f(XIN)=16MHz, without software wait)
2.4V to 3.6V (f(XIN)=7MHz, without software wait)
2.2V to 3.6V (f(XIN)=7MHz, with software one-wait) :mask ROM version
- Low power consumption 34.0mW (VCC = 3V, f(XIN)=10MHz, without software wait)
66.0mW (VCC = 3.3V, f(XIN)=16MHz, without software wait)
- Interrupts 25 internal and 8 external interrupt sources, 4 software interrupt sources; 7 levels (including key input interrupt)
- Multifunction 16-bit timer 5 output timers + 6 input timers
- Serial I/O 5 channels (3 for UART or clock synchronous, 2 for clock synchronous)
- DMAC 2 channels (trigger: 25 sources)
- A-D converter 10 bits X 8 channels (Expandable up to 18 channels)
- D-A converter 8 bits X 2 channels
- CRC calculation circuit 1 circuit
- Watchdog timer 1 line
- Programmable I/O 87 lines
- Input port 1 line (P85 shared with $\overline{\text{NMI}}$ pin)
- Memory expansion Available (to 4M bytes)
- Chip select output 4 lines
- Clock generating circuit 2 built-in clock generation circuits
(built-in feedback resistor, and external ceramic or quartz oscillator)

Applications

Audio, cameras, office equipment, communications equipment, portable equipment

-----Table of Contents-----

Central Processing Unit (CPU)	11	Timer	81
Reset	14	Serial I/O	111
Processor Mode	25	A-D Converter	152
Clock Generating Circuit	39	D-A Converter	162
Protection	48	CRC Calculation Circuit	164
Interrupts	49	Programmable I/O Ports	166
Watchdog Timer	69	Electrical characteristics	176
DMAC	71	Flash memory version	191

Description

Pin Configuration

Figures 1.1.1 and 1.1.2 show the pin configurations (top view).

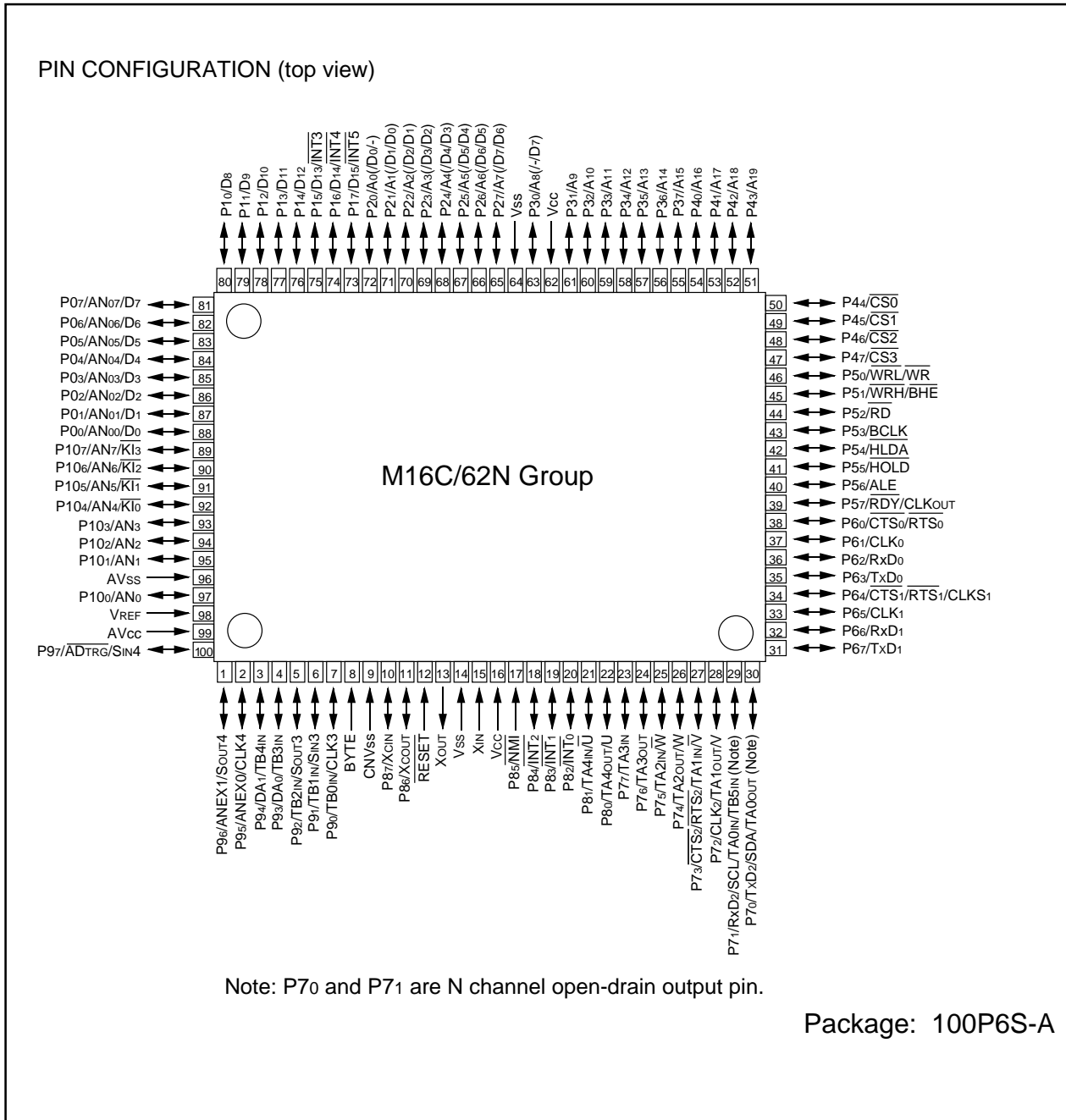

Figure 1.1.1. Pin configuration (top view)

Description

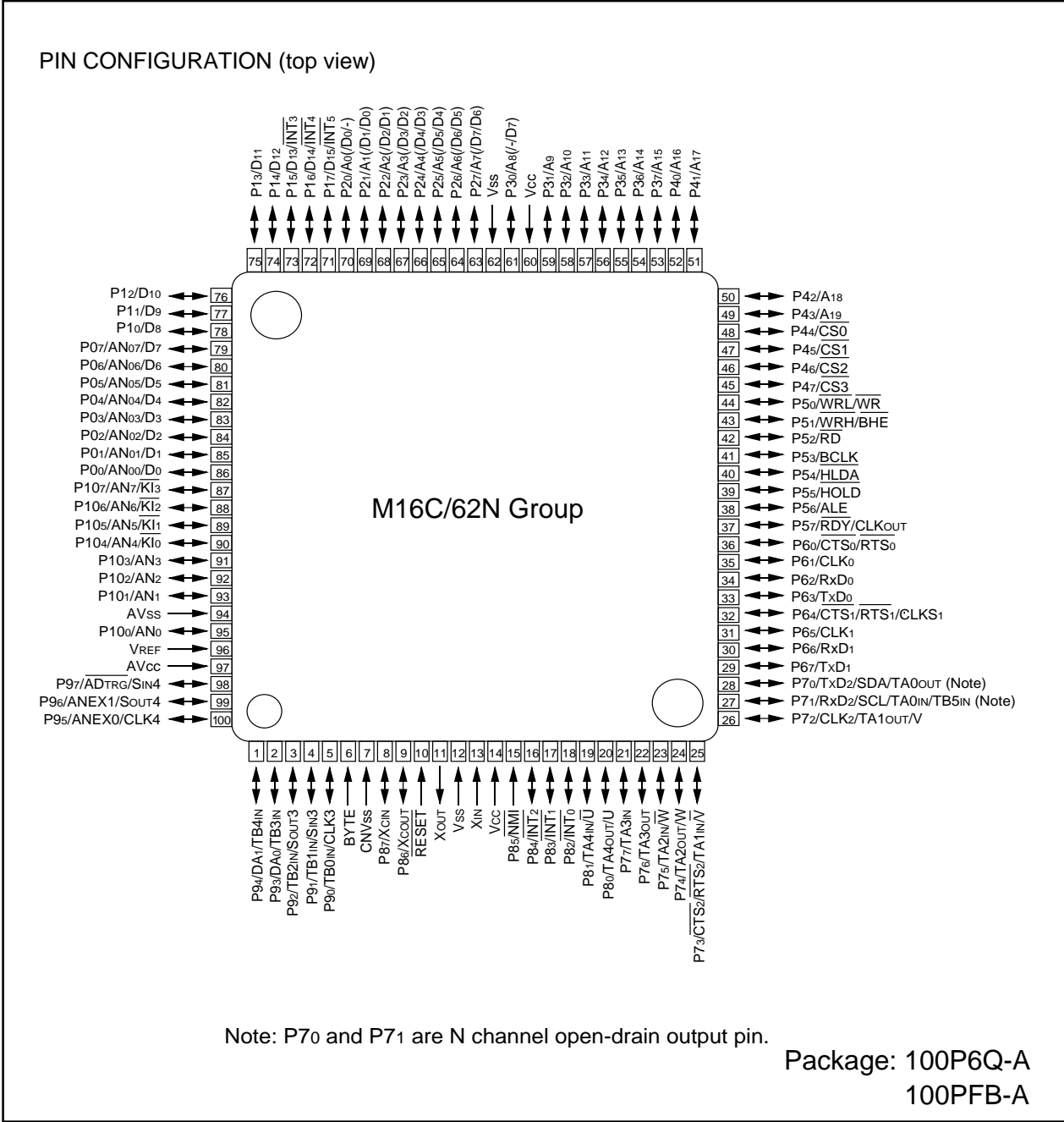

Figure 1.1.2. Pin configuration (top view)

Description

Block Diagram

Figure 1.1.3 is a block diagram of the M16C/62N group.

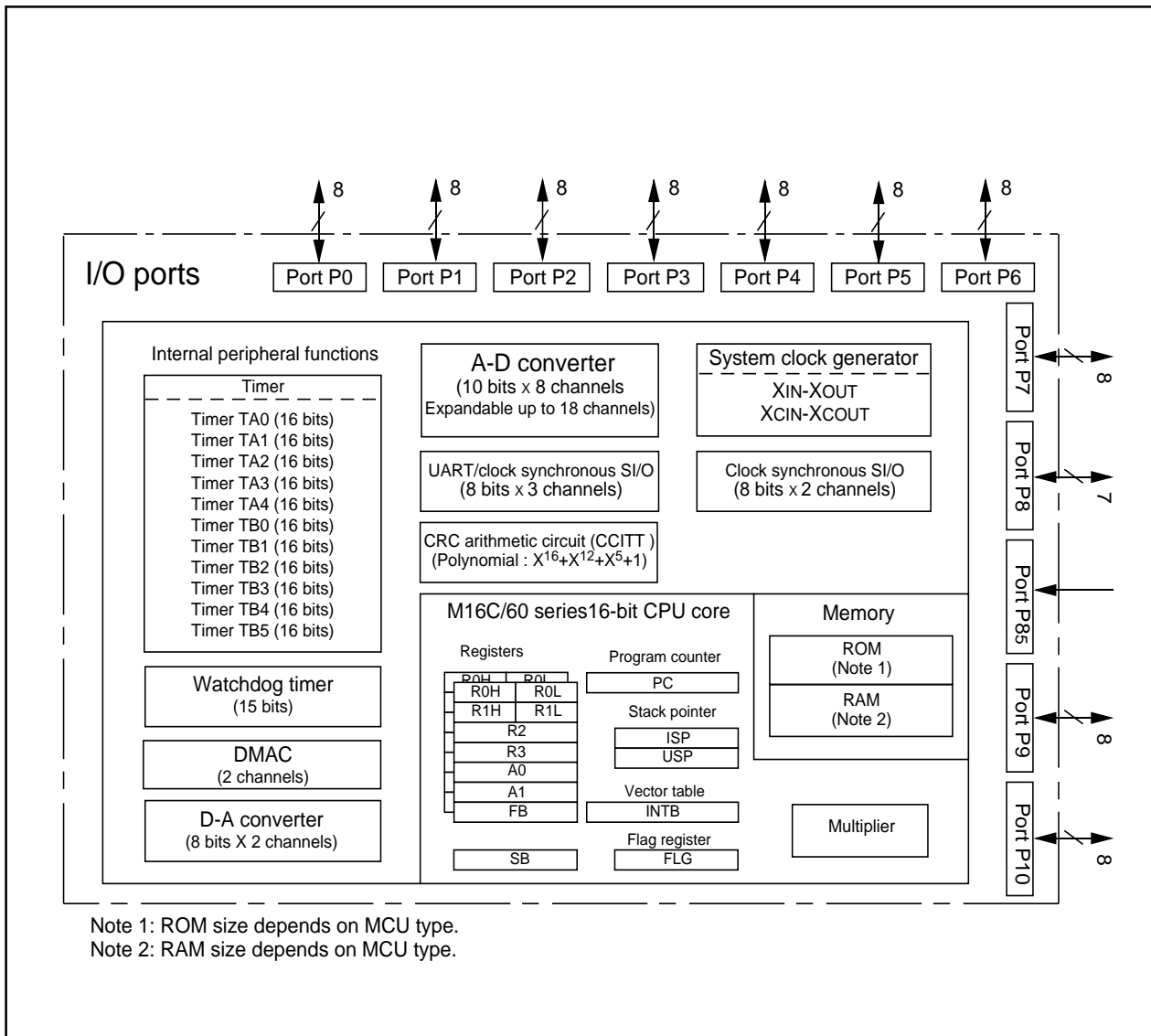

Figure 1.1.3. Block diagram of M16C/62N group

Description

Performance Outline

Table 1.1.1 is a performance outline of M16C/62N group.

Table 1.1.1. Performance outline of M16C/62N group

Item		Performance
Number of basic instructions		91 instructions
Shortest instruction execution time		62.5ns($f(X_{IN})=16\text{MHz}$, $V_{CC}=3.0\text{V}$ to 3.6V) 142.9ns($f(X_{IN})=7\text{MHz}$, $V_{CC}=2.4\text{V}$ to 3.6V , without software wait)
Memory capacity	ROM	(See the figure 1.1.4. ROM Expansion)
	RAM	10K to 20K bytes
I/O port	P0 to P10 (except P85)	8 bits x 10, 7 bits x 1
Input port	P85	1 bit x 1
Multifunction timer	TA0, TA1, TA2, TA3, TA4	16 bits x 5
	TB0, TB1, TB2, TB3, TB4, TB5	16 bits x 6
Serial I/O	UART0, UART1, UART2	(UART or clock synchronous) x 3
	SI/O3, SI/O4	(Clock synchronous) x 2
A-D converter		10 bits x (8 x 2 + 2) channels
D-A converter		8 bits x 2
DMAC		2 channels (trigger: 25 sources)
CRC calculation circuit		CRC-CCITT
Watchdog timer		15 bits x 1 (with prescaler)
Interrupt		25 internal and 8 external sources, 4 software sources, 7 levels
Clock generating circuit		2 built-in clock generation circuits (built-in feedback resistor, and external ceramic or quartz oscillator)
Supply voltage		3.0V to 3.6V ($f(X_{IN})=16\text{MHz}$, without software wait) 2.4V to 3.6V ($f(X_{IN})=7\text{MHz}$, without software wait) 2.2V to 3.6V ($f(X_{IN})=7\text{MHz}$, with software one-wait):mask ROM version
Power consumption		34.0mW ($V_{CC}=3\text{V}$, $f(X_{IN})=10\text{MHz}$, without software wait) 66.0mW ($V_{CC}=3.3\text{V}$, $f(X_{IN})=16\text{MHz}$, without software wait)
I/O characteristics	I/O withstand voltage	3.3V
	Output current	1mA
Memory expansion		Available (to 4M bytes)
Device configuration		CMOS high performance silicon gate
Package		100-pin plastic molded QFP

Description

Mitsubishi plans to release the following products in the M16C/62N group:

- (1) Support for mask ROM version and flash memory version
- (2) ROM capacity
- (3) Package

- 100P6S-A : Plastic molded QFP (mask ROM and flash memory versions)
- 100P6Q-A : Plastic molded QFP (mask ROM and flash memory versions)
- 100PFB-A : Plastic molded QFP (mask ROM and flash memory versions)

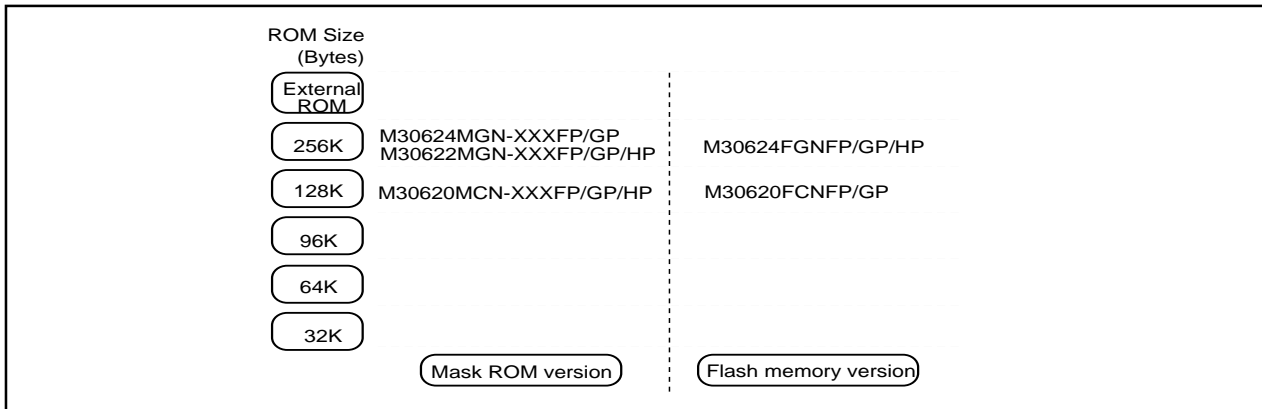

Figure 1.1.4. ROM expansion

The M16C/62N group products currently supported are listed in Table 1.1.2.

Table 1.1.2. M16C/62N group

As of August 2002

Type No.	ROM capacity	RAM capacity	Package type	Remarks
M30620MCN-XXXFP	128K bytes	10K bytes	100P6S-A	Mask ROM version
M30620MCN-XXXGP			100P6Q-A	
M30620MCN-XXXHP **			100PFB-A	
M30622MGN-XXXFP	256K bytes	12K bytes	100P6S-A	
M30622MGN-XXXGP			100P6Q-A	
M30622MGN-XXXHP **			100PFB-A	
M30624MGN-XXXFP	256K bytes	20K bytes	100P6S-A	Flash memory version
M30624MGN-XXXGP			100P6Q-A	
M30620FCNFP	128K bytes	10K bytes	100P6S-A	
M30620FCNGP			100P6Q-A	
M30624FGNFP	256K bytes	20K bytes	100P6S-A	
M30624FGNGP			100P6Q-A	
M30624FGNHP **			100PFB-A	

** : Under development

Description

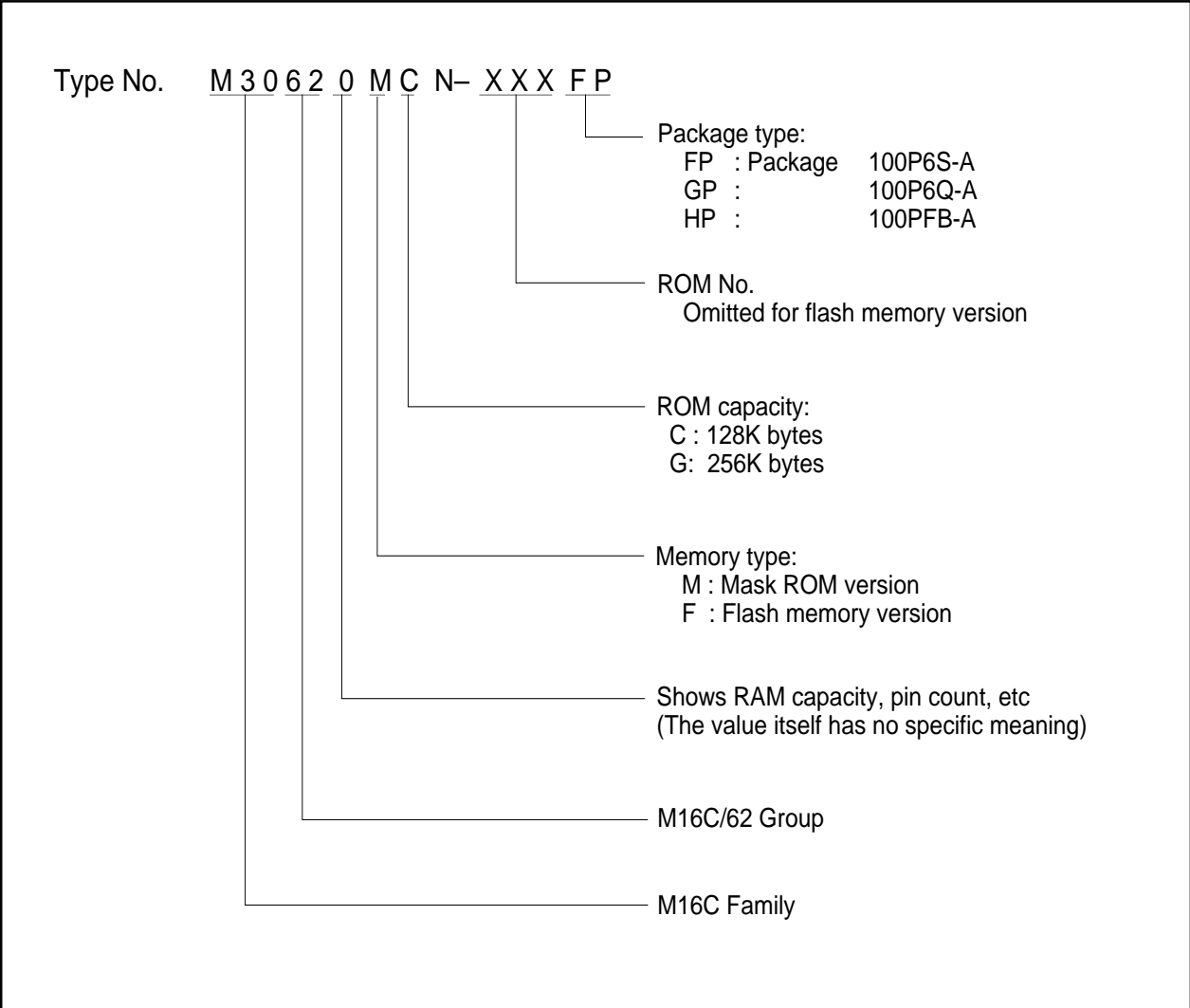

Figure 1.1.5. Type No., memory size, and package

Pin Description

Pin Description

Pin name	Signal name	I/O type	Function
Vcc, Vss	Power supply input		Supply 2.2V to 3.6 V (mask ROM version), 2.4V to 3.6 V (flash memory version) to the Vcc pin. Supply 0 V to the Vss pin.
CNVss	CNVss	Input	This pin switches between processor modes. Connect this pin to the Vss pin when after a reset you want to start operation in single-chip mode (memory expansion mode) or the Vcc pin when starting operation in microprocessor mode.
RESET	Reset input	Input	A "L" on this input resets the microcomputer.
XIN XOUT	Clock input Clock output	Input Output	These pins are provided for the main clock generating circuit. Connect a ceramic resonator or crystal between the XIN and the XOUT pins. To use an externally derived clock, input it to the XIN pin and leave the XOUT pin open.
BYTE	External data bus width select input	Input	This pin selects the width of an external data bus. A 16-bit width is selected when this input is "L"; an 8-bit width is selected when this input is "H". This input must be fixed to either "H" or "L". Connect this pin to the Vss pin when not using external data bus.
AVcc	Analog power supply input		This pin is a power supply input for the A-D converter. Connect this pin to Vcc.
AVss	Analog power supply input		This pin is a power supply input for the A-D converter. Connect this pin to Vss.
VREF	Reference voltage input	Input	This pin is a reference voltage input for the A-D converter.
P0 ₀ to P0 ₇	I/O port P0	Input/output	This is an 8-bit CMOS I/O port. It has an input/output port direction register that allows the user to set each pin for input or output individually. When used for input in single-chip mode, the port can be set to have or not have a pull-up resistor in units of four bits by software. In memory expansion and microprocessor modes, selection of the internal pull-resistor is not available. When used for single-chip mode, P0 also function as A-D converter extended input pins as selected by software.
D ₀ to D ₇		Input/output	When set as a separate bus, these pins input and output data (D ₀ –D ₇).
P1 ₀ to P1 ₇	I/O port P1	Input/output	This is an 8-bit I/O port equivalent to P0. P1 ₅ to P1 ₇ also function as external interrupt pins as selected by software.
D ₈ to D ₁₅		Input/output	When set as a separate bus, these pins input and output data (D ₈ –D ₁₅).
P2 ₀ to P2 ₇	I/O port P2	Input/output	This is an 8-bit I/O port equivalent to P0.
A ₀ to A ₇		Output	These pins output 8 low-order address bits (A ₀ –A ₇).
A ₀ /D ₀ to A ₇ /D ₇		Input/output	If the external bus is set as an 8-bit wide multiplexed bus, these pins input and output data (D ₀ –D ₇) and output 8 low-order address bits (A ₀ –A ₇) separated in time by multiplexing.
A ₀ A ₁ /D ₀ to A ₇ /D ₆		Output Input/output	If the external bus is set as a 16-bit wide multiplexed bus, these pins input and output data (D ₀ –D ₆) and output address (A ₁ –A ₇) separated in time by multiplexing. They also output address (A ₀).
P3 ₀ to P3 ₇	I/O port P3	Input/output	This is an 8-bit I/O port equivalent to P0.
A ₈ to A ₁₅		Output	These pins output 8 middle-order address bits (A ₈ –A ₁₅).
A ₈ /D ₇ , A ₉ to A ₁₅		Input/output Output	If the external bus is set as a 16-bit wide multiplexed bus, these pins input and output data (D ₇) and output address (A ₈) separated in time by multiplexing. They also output address (A ₉ –A ₁₅).
P4 ₀ to P4 ₇	I/O port P4	Input/output	This is an 8-bit I/O port equivalent to P0.
A ₁₆ to A ₁₉ , CS ₀ to CS ₃		Output Output	These pins output A ₁₆ –A ₁₉ and CS ₀ –CS ₃ signals. A ₁₆ –A ₁₉ are 4 high-order address bits. CS ₀ –CS ₃ are chip select signals used to specify an access space.

Pin Description

Pin Description

Pin name	Signal name	I/O type	Function
P50 to P57	I/O port P5	Input/output	This is an 8-bit I/O port equivalent to P0. In single-chip mode, P57 in this port outputs a divide-by-8 or divide-by-32 clock of XIN or a clock of the same frequency as XCIN as selected by software.
\overline{WRL} / \overline{WR} , \overline{WRH} / \overline{BHE} , RD, BCLK, HLDA, HOLD, ALE, RDY		Output Output Output Output Output Input Output Input	Output \overline{WRL} , \overline{WRH} (\overline{WR} and \overline{BHE}), RD, BCLK, HLDA, and ALE signals. \overline{WRL} and \overline{WRH} , and \overline{BHE} and \overline{WR} can be switched using software control. ■ \overline{WRL} , \overline{WRH} , and RD selected With a 16-bit external data bus, data is written to even addresses when the \overline{WRL} signal is "L" and to the odd addresses when the \overline{WRH} signal is "L". Data is read when RD is "L". ■ \overline{WR} , \overline{BHE} , and RD selected Data is written when \overline{WR} is "L". Data is read when \overline{RD} is "L". Odd addresses are accessed when \overline{BHE} is "L". Use this mode when using an 8-bit external data bus. While the input level at the HOLD pin is "L", the microcomputer is placed in the hold state. While in the hold state, HLDA outputs a "L" level. ALE is used to latch the address. While the input level of the RDY pin is "L", the microcomputer is in the ready state.
P60 to P67	I/O port P6	Input/output	This is an 8-bit I/O port equivalent to P0. When used for input in single-chip, memory expansion, and microprocessor modes, the port can be set to have or not have a pull-up resistor in units of four bits by software. Pins in this port also function as UART0 and UART1 I/O pins as selected by software.
P70 to P77	I/O port P7	Input/output	This is an 8-bit I/O port equivalent to P6 (P70 and P71 are N channel open-drain output). Pins in this port also function as timer A0–A3, timer B5 or UART2 I/O pins as selected by software.
P80 to P84, P86, P87, P85	I/O port P8 I/O port P85	Input/output Input/output Input/output Input	P80 to P84, P86, and P87 are I/O ports with the same functions as P6. Using software, they can be made to function as the I/O pins for timer A4 and the input pins for external interrupts. P86 and P87 can be set using software to function as the I/O pins for a sub clock generation circuit. In this case, connect a quartz oscillator between P86 (XCOUT pin) and P87 (XCIN pin). P85 is an input-only port that also functions for NMI. The NMI interrupt is generated when the input at this pin changes from "H" to "L". The NMI function cannot be cancelled using software. The pull-up cannot be set for this pin.
P90 to P97	I/O port P9	Input/output	This is an 8-bit I/O port equivalent to P6. Pins in this port also function as SI/O3, 4 I/O pins, Timer B0–B4 input pins, D-A converter output pins, A-D converter extended input pins, or A-D trigger input pins as selected by software.
P100 to P107	I/O port P10	Input/output	This is an 8-bit I/O port equivalent to P6. Pins in this port also function as A-D converter input pins as selected by software. Furthermore, P104–P107 also function as input pins for the key input interrupt function.

Operation of Functional Blocks

The M16C/62N group accommodates certain units in a single chip. These units include ROM and RAM to store instructions and data and the central processing unit (CPU) to execute arithmetic/logic operations. Also included are peripheral units such as timers, serial I/O, D-A converter, DMAC, CRC calculation circuit, A-D converter, and I/O ports.

The following explains each unit.

Memory

Figure 1.3.1 is a memory map of the M16C/62N group. The address space extends the 1M bytes from address 00000_{16} to $FFFFFF_{16}$. From $FFFFFF_{16}$ down is ROM. For example, in the M30620MCN-XXXFP, there is 128K bytes of internal ROM from $E0000_{16}$ to $FFFFFF_{16}$. The vector table for fixed interrupts such as the reset and $\overline{\text{NMI}}$ are mapped to $FFFDC_{16}$ to $FFFFFF_{16}$. The starting address of the interrupt routine is stored here. The address of the vector table for timer interrupts, etc., can be set as desired using the internal register (INTB). See the section on interrupts for details.

From 00400_{16} up is RAM. For example, in the M30620MCN-XXXFP, 12K bytes of internal RAM is mapped to the space from 00400_{16} to $033FF_{16}$. In addition to storing data, the RAM also stores the stack used when calling subroutines and when interrupts are generated.

The SFR area is mapped to 00000_{16} to $003FF_{16}$. This area accommodates the control registers for peripheral devices such as I/O ports, A-D converter, serial I/O, and timers, etc. Figures 1.6.1 to 1.6.3 are location of peripheral unit control registers. Any part of the SFR area that is not occupied is reserved and cannot be used for other purposes.

The special page vector table is mapped to $FFE00_{16}$ to $FFFDB_{16}$. If the starting addresses of subroutines or the destination addresses of jumps are stored here, subroutine call instructions and jump instructions can be used as 2-byte instructions, reducing the number of program steps.

In memory expansion mode and microprocessor mode, a part of the spaces are reserved and cannot be used. For example, in the M30620MCN-XXXFP, the following spaces cannot be used.

- The space between 03400_{16} and $03FFF_{16}$ (Memory expansion and microprocessor modes)
- The space between $D0000_{16}$ and $DFFFF_{16}$ (Memory expansion mode)

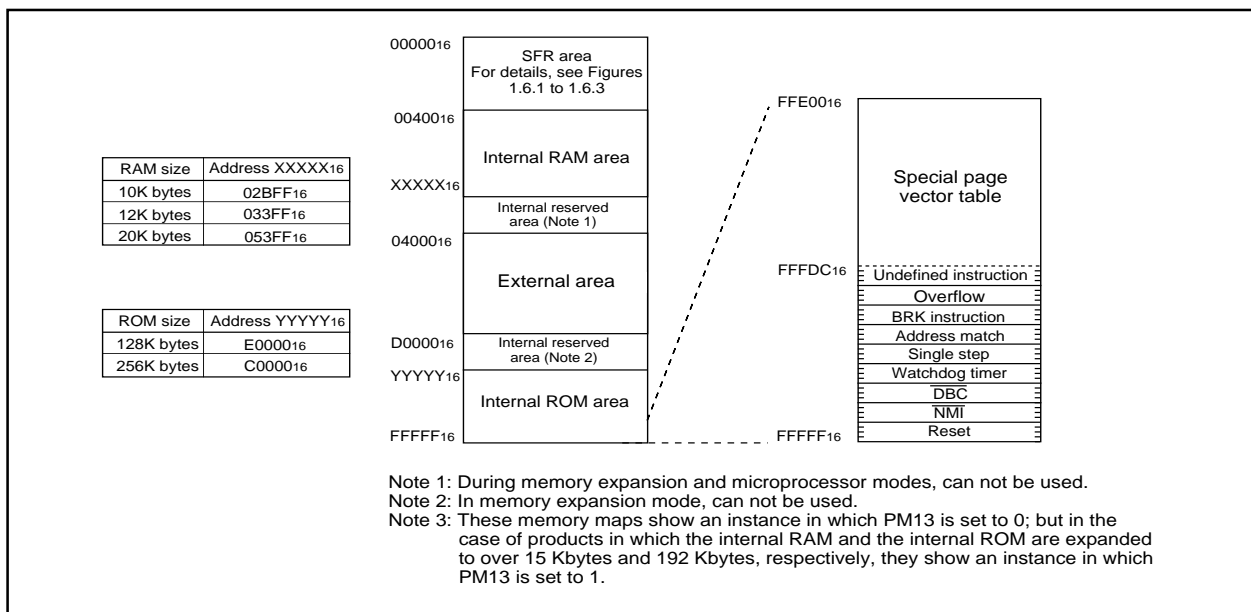

Figure 1.3.1. Memory map

Central Processing Unit (CPU)

The CPU has a total of 13 registers shown in Figure 1.4.1. Seven of these registers (R0, R1, R2, R3, A0, A1, and FB) come in two sets; therefore, these have two register banks.

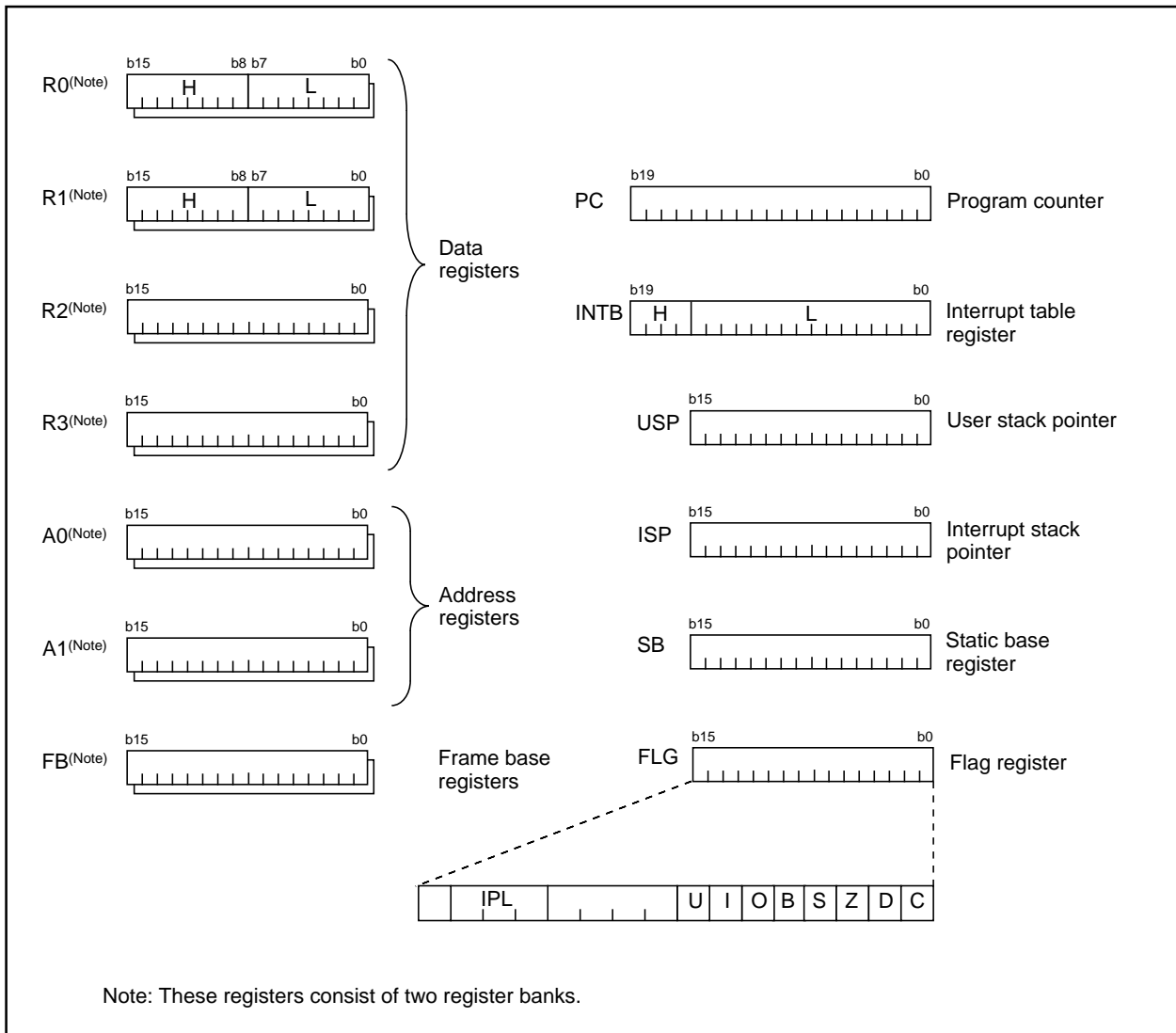

Figure 1.4.1. Central processing unit register

(1) Data registers (R0, R0H, R0L, R1, R1H, R1L, R2, and R3)

Data registers (R0, R1, R2, and R3) are configured with 16 bits, and are used primarily for transfer and arithmetic/logic operations.

Registers R0 and R1 each can be used as separate 8-bit data registers, high-order bits as (R0H/R1H), and low-order bits as (R0L/R1L). In some instructions, registers R2 and R0, as well as R3 and R1 can use as 32-bit data registers (R2R0/R3R1).

(2) Address registers (A0 and A1)

Address registers (A0 and A1) are configured with 16 bits, and have functions equivalent to those of data registers. These registers can also be used for address register indirect addressing and address register relative addressing.

In some instructions, registers A1 and A0 can be combined for use as a 32-bit address register (A1A0).

(3) Frame base register (FB)

Frame base register (FB) is configured with 16 bits, and is used for FB relative addressing.

(4) Program counter (PC)

Program counter (PC) is configured with 20 bits, indicating the address of an instruction to be executed.

(5) Interrupt table register (INTB)

Interrupt table register (INTB) is configured with 20 bits, indicating the start address of an interrupt vector table.

(6) Stack pointer (USP/ISP)

Stack pointer comes in two types: user stack pointer (USP) and interrupt stack pointer (ISP), each configured with 16 bits.

Your desired type of stack pointer (USP or ISP) can be selected by a stack pointer select flag (U flag).

This flag is located at the position of bit 7 in the flag register (FLG).

(7) Static base register (SB)

Static base register (SB) is configured with 16 bits, and is used for SB relative addressing.

(8) Flag register (FLG)

Flag register (FLG) is configured with 11 bits, each bit is used as a flag. Figure 1.4.2 shows the flag register (FLG). The following explains the function of each flag:

• Bit 0: Carry flag (C flag)

This flag retains a carry, borrow, or shift-out bit that has occurred in the arithmetic/logic unit.

• Bit 1: Debug flag (D flag)

This flag enables a single-step interrupt.

When this flag is "1", a single-step interrupt is generated after instruction execution. This flag is cleared to "0" when the interrupt is acknowledged.

• Bit 2: Zero flag (Z flag)

This flag is set to "1" when an arithmetic operation resulted in 0; otherwise, cleared to "0".

• Bit 3: Sign flag (S flag)

This flag is set to "1" when an arithmetic operation resulted in a negative value; otherwise, cleared to "0".

• Bit 4: Register bank select flag (B flag)

This flag chooses a register bank. Register bank 0 is selected when this flag is "0"; register bank 1 is selected when this flag is "1".

• Bit 5: Overflow flag (O flag)

This flag is set to "1" when an arithmetic operation resulted in overflow; otherwise, cleared to "0".

• Bit 6: Interrupt enable flag (I flag)

This flag enables a maskable interrupt.

An interrupt is disabled when this flag is "0", and is enabled when this flag is "1". This flag is cleared to "0" when the interrupt is acknowledged.

- **Bit 7: Stack pointer select flag (U flag)**

Interrupt stack pointer (ISP) is selected when this flag is “0” ; user stack pointer (USP) is selected when this flag is “1”.

This flag is cleared to “0” when a hardware interrupt is acknowledged or an INT instruction of software interrupt Nos. 0 to 31 is executed.

- **Bits 8 to 11: Reserved area**

- **Bits 12 to 14: Processor interrupt priority level (IPL)**

Processor interrupt priority level (IPL) is configured with three bits, for specification of up to eight processor interrupt priority levels from level 0 to level 7.

If a requested interrupt has priority greater than the processor interrupt priority level (IPL), the interrupt is enabled.

- **Bit 15: Reserved area**

The C, Z, S, and O flags are changed when instructions are executed. See the software manual for details.

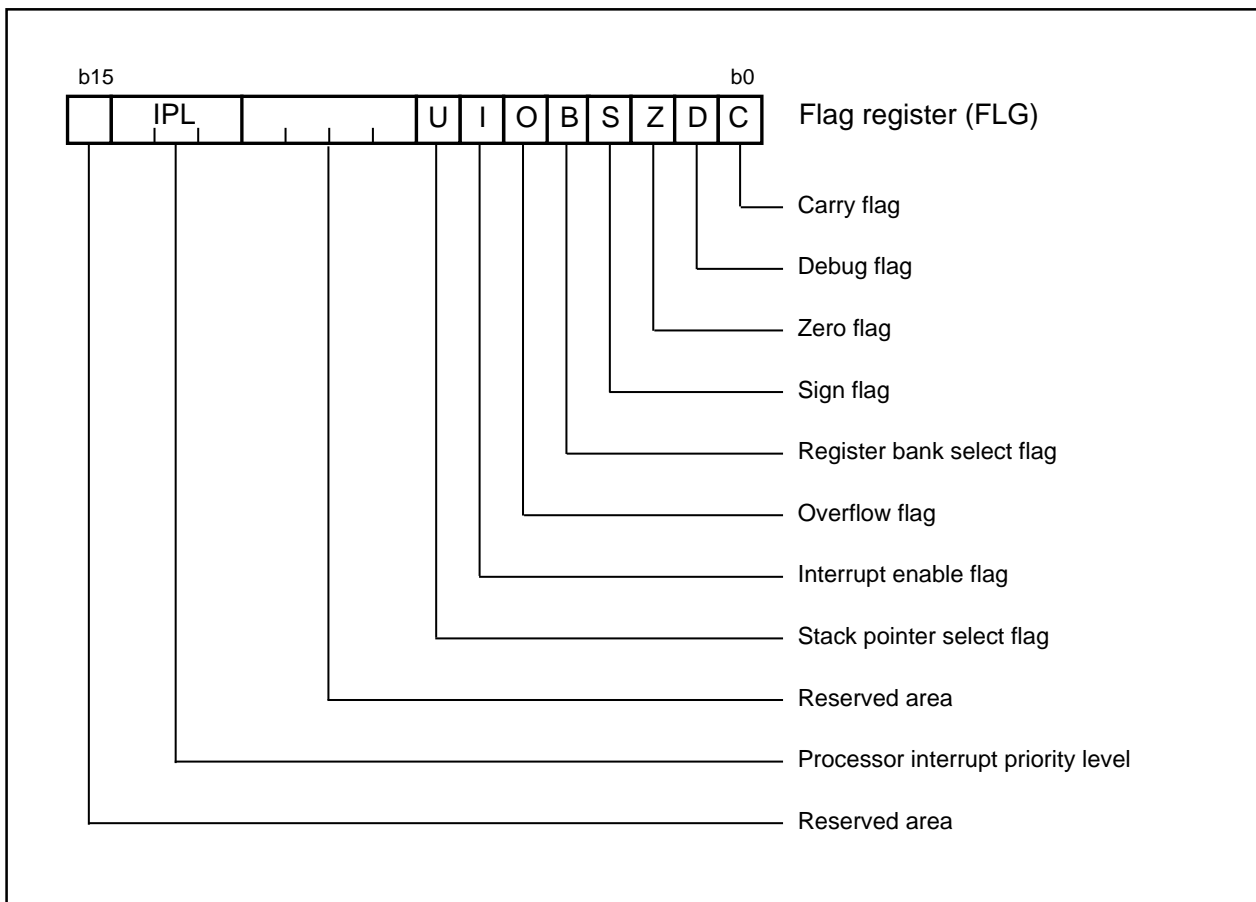

Figure 1.4.2. Flag register (FLG)

Reset

Reset

There are two kinds of resets; hardware and software. In both cases, operation is the same after the reset. (See "Software Reset" for details of software resets.) This section explains on hardware resets.

When the supply voltage is in the range where operation is guaranteed, a reset is effected by holding the reset pin level "L" (0.2V_{CC} max.) for at least 20 cycles. When the reset pin level is then returned to the "H" level while main clock is stable, the reset status is cancelled and program execution resumes from the address in the reset vector table.

The RAM is undefined at power on. The initial values must therefore be set. When a reset signal is applied while the CPU is writing a value to the RAM, the value may be set as unknown due to the termination of the CPU access.

Figure 1.5.1 shows the example reset circuit. Figure 1.5.2 shows the reset sequence.

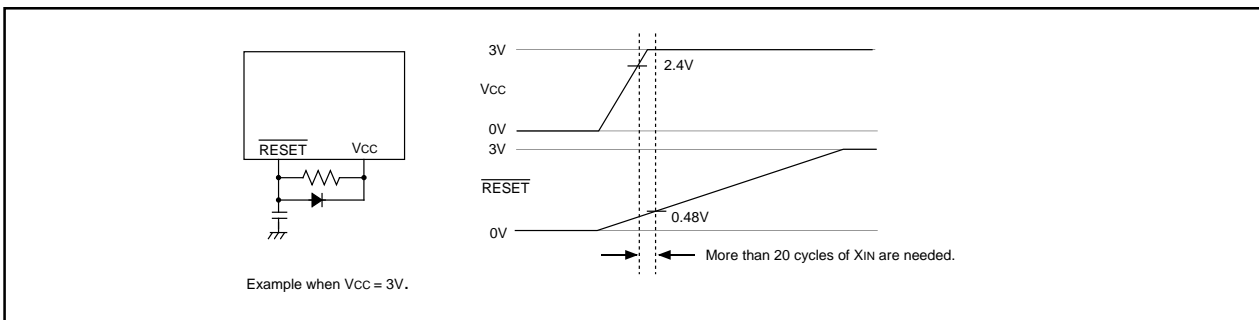

Figure 1.5.1. Example reset circuit

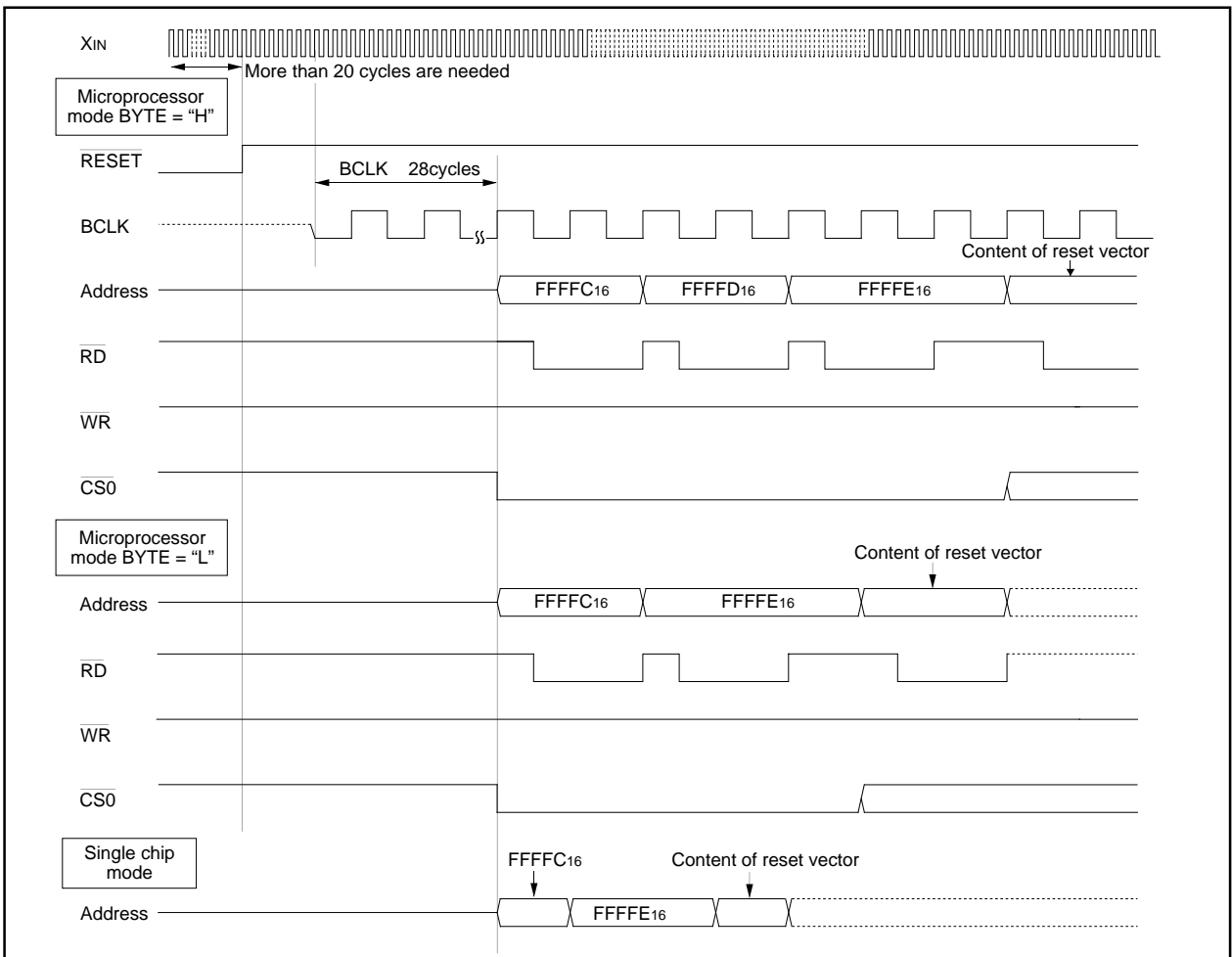

Figure 1.5.2. Reset sequence

Table 1.5.1 shows the statuses of the other pins while the $\overline{\text{RESET}}$ pin level is "L". Figures 1.5.3 and 1.5.4 show the internal status of the microcomputer immediately after the reset is cancelled.

Table 1.5.1. Pin status when $\overline{\text{RESET}}$ pin level is "L"

Pin name	Status		
	CNVss = Vss	CNVss = Vcc	
		BYTE = Vss	BYTE = Vcc
P0	Input port (floating)	Data input (floating)	Data input (floating)
P1	Input port (floating)	Data input (floating)	Input port (floating)
P2, P3, P40 to P43	Input port (floating)	Address output (undefined)	Address output (undefined)
P44	Input port (floating)	$\overline{\text{CS0}}$ output ("H" level is output)	$\overline{\text{CS0}}$ output ("H" level is output)
P45 to P47	Input port (floating)	Input port (floating) (pull-up resistor is on)	Input port (floating) (pull-up resistor is on)
P50	Input port (floating)	$\overline{\text{WR}}$ output ("H" level is output)	$\overline{\text{WR}}$ output ("H" level is output)
P51	Input port (floating)	$\overline{\text{BHE}}$ output (undefined)	$\overline{\text{BHE}}$ output (undefined)
P52	Input port (floating)	$\overline{\text{RD}}$ output ("H" level is output)	$\overline{\text{RD}}$ output ("H" level is output)
P53	Input port (floating)	BCLK output	BCLK output
P54	Input port (floating)	$\overline{\text{HLDA}}$ output (The output value depends on the input to the HOLD pin)	$\overline{\text{HLDA}}$ output (The output value depends on the input to the HOLD pin)
P55	Input port (floating)	HOLD input (floating)	HOLD input (floating)
P56	Input port (floating)	ALE output ("L" level is output)	ALE output ("L" level is output)
P57	Input port (floating)	$\overline{\text{RDY}}$ input (floating)	$\overline{\text{RDY}}$ input (floating)
P6, P7, P80 to P84, P86, P87, P9, P10	Input port (floating)	Input port (floating)	Input port (floating)

(1) Processor mode register 0 (Note)	(000416)...	0016	(29) UART1 transmit interrupt control register	(005316)...	XXXXXXXX?000
(2) Processor mode register 1	(000516)...	0000000X	(30) UART1 receive interrupt control register	(005416)...	XXXXXXXX?000
(3) System clock control register 0	(000616)...	01001000	(31) Timer A0 interrupt control register	(005516)...	XXXXXXXX?000
(4) System clock control register 1	(000716)...	00100000	(32) Timer A1 interrupt control register	(005616)...	XXXXXXXX?000
(5) Chip select control register	(000816)...	00000001	(33) Timer A2 interrupt control register	(005716)...	XXXXXXXX?000
(6) Address match interrupt enable register	(000916)...	XXXXXXXX00	(34) Timer A3 interrupt control register	(005816)...	XXXXXXXX?000
(7) Protect register	(000A16)...	XXXXXXXX00	(35) Timer A4 interrupt control register	(005916)...	XXXXXXXX?000
(8) Data bank register	(000B16)...	0016	(36) Timer B0 interrupt control register	(005A16)...	XXXXXXXX?000
(9) Watchdog timer control register	(000F16)...	000???	(37) Timer B1 interrupt control register	(005B16)...	XXXXXXXX?000
(10) Address match interrupt register 0	(001016)...	0016	(38) Timer B2 interrupt control register	(005C16)...	XXXXXXXX?000
	(001116)...	0016	(39) INT0 interrupt control register	(005D16)...	XXXX00?000
	(001216)...	XXXXXXXX0000	(40) INT1 interrupt control register	(005E16)...	XXXX00?000
(11) Address match interrupt register 1	(001416)...	0016	(41) INT2 interrupt control register	(005F16)...	XXXX00?000
	(001516)...	0016	(42) Timer B3,4,5 count start flag	(034016)...	000XXXXX
	(001616)...	XXXXXXXX0000	(43) Three-phase PWM control register 0	(034816)...	0016
(12) DMA0 control register	(002C16)...	000000?000	(44) Three-phase PWM control register 1	(034916)...	0016
(13) DMA1 control register	(003C16)...	000000?000	(45) Three-phase output buffer register 0	(034A16)...	0016
(14) INT3 interrupt control register	(004416)...	XXXX0?0000	(46) Three-phase output buffer register 1	(034B16)...	0016
(15) Timer B5 interrupt control register	(004516)...	XXXXXXXX?000	(47) Timer B3 mode register	(035B16)...	00??0000
(16) Timer B4 interrupt control register	(004616)...	XXXXXXXX?000	(48) Timer B4 mode register	(035C16)...	00?X0000
(17) Timer B3 interrupt control register	(004716)...	XXXXXXXX?000	(49) Timer B5 mode register	(035D16)...	00?X0000
(18) SI/O4 interrupt control register	(004816)...	XXXX0?0000	(50) Interrupt cause select register	(035F16)...	0016
(19) SI/O3 interrupt control register	(004916)...	XXXX0?0000	(51) SI/O3 control register	(036216)...	4016
(20) Bus collision detection interrupt control register	(004A16)...	XXXXXXXX?000	(52) SI/O4 control register	(036616)...	4016
(21) DMA0 interrupt control register	(004B16)...	XXXXXXXX?000	(53) UART2 special mode register 3	(037516)...	0016
(22) DMA1 interrupt control register	(004C16)...	XXXXXXXX?000	(54) UART2 special mode register 2	(037616)...	0016
(23) Key input interrupt control register	(004D16)...	XXXXXXXX?000	(55) UART2 special mode register	(037716)...	8016
(24) A-D conversion interrupt control register	(004E16)...	XXXXXXXX?000	(56) UART2 transmit/receive mode register	(037816)...	0016
(25) UART2 transmit interrupt control register	(004F16)...	XXXXXXXX?000	(57) UART2 transmit/receive control register 0	(037C16)...	00001000
(26) UART2 receive interrupt control register	(005016)...	XXXXXXXX?000	(58) UART2 transmit/receive control register 1	(037D16)...	00000010
(27) UART0 transmit interrupt control register	(005116)...	XXXXXXXX?000			
(28) UART0 receive interrupt control register	(005216)...	XXXXXXXX?000			

x : Nothing is mapped to this bit
? : Undefined

The content of other registers are undefined when the microcomputer is reset. The initial values must therefore be set. The RAM is undefined at power on. The initial values must therefore be set. When a reset signal is applied while the CPU is writing a value to the RAM, the value may be set as unknown due to the termination of the CPU access.

Note : When the VCC level is applied to the CNVSS pin, it is 0316 at a reset.

Figure 1.5.3. Device's internal status after a reset is cleared

Reset

(59) Count start flag	(0380 ₁₆)...	00 ₁₆	(85) A-D control register 1	(03D7 ₁₆)...	00 ₁₆
(60) Clock prescaler reset flag	(0381 ₁₆)...	0x	(86) D-A control register	(03DC ₁₆)...	00 ₁₆
(61) One-shot start flag	(0382 ₁₆)...	00x	(87) Port P0 direction register	(03E2 ₁₆)...	00 ₁₆
(62) Trigger select flag	(0383 ₁₆)...	00 ₁₆	(88) Port P1 direction register	(03E3 ₁₆)...	00 ₁₆
(63) Up-down flag	(0384 ₁₆)...	00 ₁₆	(89) Port P2 direction register	(03E6 ₁₆)...	00 ₁₆
(64) Timer A0 mode register	(0396 ₁₆)...	00 ₁₆	(90) Port P3 direction register	(03E7 ₁₆)...	00 ₁₆
(65) Timer A1 mode register	(0397 ₁₆)...	00 ₁₆	(91) Port P4 direction register	(03EA ₁₆)...	00 ₁₆
(66) Timer A2 mode register	(0398 ₁₆)...	00 ₁₆	(92) Port P5 direction register	(03EB ₁₆)...	00 ₁₆
(67) Timer A3 mode register	(0399 ₁₆)...	00 ₁₆	(93) Port P6 direction register	(03EE ₁₆)...	00 ₁₆
(68) Timer A4 mode register	(039A ₁₆)...	00 ₁₆	(94) Port P7 direction register	(03EF ₁₆)...	00 ₁₆
(69) Timer B0 mode register	(039B ₁₆)...	00??	(95) Port P8 direction register	(03F2 ₁₆)...	00x
(70) Timer B1 mode register	(039C ₁₆)...	00?x	(96) Port P9 direction register	(03F3 ₁₆)...	00 ₁₆
(71) Timer B2 mode register	(039D ₁₆)...	00?x	(97) Port P10 direction register	(03F6 ₁₆)...	00 ₁₆
(72) UART0 transmit/receive mode register	(03A0 ₁₆)...	00 ₁₆	(98) Pull-up control register 0	(03FC ₁₆)...	00 ₁₆
(73) UART0 transmit/receive control register 0	(03A4 ₁₆)...	000010	(99) Pull-up control register 1 (Note1)	(03FD ₁₆)...	00 ₁₆
(74) UART0 transmit/receive control register 1	(03A5 ₁₆)...	0000010	(100) Pull-up control register 2	(03FE ₁₆)...	00 ₁₆
(75) UART1 transmit/receive mode register	(03A8 ₁₆)...	00 ₁₆	(101) Port control register	(03FF ₁₆)...	00 ₁₆
(76) UART1 transmit/receive control register 0	(03AC ₁₆)...	000010	(102) Data registers (R0/R1/R2/R3)		0000 ₁₆
(77) UART1 transmit/receive control register 1	(03AD ₁₆)...	0000010	(103) Address registers (A0/A1)		0000 ₁₆
(78) UART transmit/receive control register 2	(03B0 ₁₆)...	x00000	(104) Frame base register (FB)		0000 ₁₆
(79) Flash identification register (Note2)	(03B4 ₁₆)...	00 ₁₆	(105) Interrupt table register (INTB)		00000 ₁₆
(80) Flash memory control register 0 (Note2)	(03B7 ₁₆)...	xx00001	(106) User stack pointer (USP)		0000 ₁₆
(81) DMA0 cause select register	(03B8 ₁₆)...	00 ₁₆	(107) Interrupt stack pointer (ISP)		0000 ₁₆
(82) DMA1 cause select register	(03BA ₁₆)...	00 ₁₆	(108) Static base register (SB)		0000 ₁₆
(83) A-D control register 2	(03D4 ₁₆)...	0000xx	(109) Flag register (FLG)		0000 ₁₆
(84) A-D control register 0	(03D6 ₁₆)...	0000???			

x : Nothing is mapped to this bit
? : Undefined

The content of other registers are undefined when the microcomputer is reset. The initial values must therefore be set. The RAM is undefined at power on. The initial values must therefore be set. When a reset signal is applied while the CPU is writing a value to the RAM, the value may be set as unknown due to the termination of the CPU access.

Note 1: When the VCC level is applied to the CNVSS pin, it is 02₁₆ at a reset.
Note 2: This register is only exist in flash memory version.

Figure 1.5.4. Device's internal status after a reset is cleared

0340 ₁₆	Timer B3, 4, 5 count start flag (TBSR)	0380 ₁₆	Count start flag (TABSR)
0341 ₁₆		0381 ₁₆	Clock prescaler reset flag (CPSRF)
0342 ₁₆		0382 ₁₆	One-shot start flag (ONSF)
0343 ₁₆	Timer A1-1 register (TA11)	0383 ₁₆	Trigger select register (TRGSR)
0344 ₁₆		0384 ₁₆	Up-down flag (UDF)
0345 ₁₆	Timer A2-1 register (TA21)	0385 ₁₆	
0346 ₁₆		0386 ₁₆	Timer A0 (TA0)
0347 ₁₆	Timer A4-1 register (TA41)	0387 ₁₆	
0348 ₁₆	Three-phase PWM control register 0(INVC0)	0388 ₁₆	Timer A1 (TA1)
0349 ₁₆	Three-phase PWM control register 1(INVC1)	0389 ₁₆	
034A ₁₆	Three-phase output buffer register 0(IDB0)	038A ₁₆	Timer A2 (TA2)
034B ₁₆	Three-phase output buffer register 1(IDB1)	038B ₁₆	
034C ₁₆	Dead time timer(DTT)	038C ₁₆	Timer A3 (TA3)
034D ₁₆	Timer B2 interrupt occurrence frequency set counter(ICTB2)	038D ₁₆	
034E ₁₆		038E ₁₆	Timer A4 (TA4)
034F ₁₆		038F ₁₆	
0350 ₁₆		0390 ₁₆	Timer B0 (TB0)
0351 ₁₆	Timer B3 register (TB3)	0391 ₁₆	
0352 ₁₆		0392 ₁₆	Timer B1 (TB1)
0353 ₁₆	Timer B4 register (TB4)	0393 ₁₆	
0354 ₁₆		0394 ₁₆	Timer B2 (TB2)
0355 ₁₆	Timer B5 register (TB5)	0395 ₁₆	
0356 ₁₆		0396 ₁₆	Timer A0 mode register (TA0MR)
0357 ₁₆		0397 ₁₆	Timer A1 mode register (TA1MR)
0358 ₁₆		0398 ₁₆	Timer A2 mode register (TA2MR)
0359 ₁₆		0399 ₁₆	Timer A3 mode register (TA3MR)
035A ₁₆		039A ₁₆	Timer A4 mode register (TA4MR)
035B ₁₆	Timer B3 mode register (TB3MR)	039B ₁₆	Timer B0 mode register (TB0MR)
035C ₁₆	Timer B4 mode register (TB4MR)	039C ₁₆	Timer B1 mode register (TB1MR)
035D ₁₆	Timer B5 mode register (TB5MR)	039D ₁₆	Timer B2 mode register (TB2MR)
035E ₁₆		039E ₁₆	
035F ₁₆	Interrupt cause select register (IFSR)	039F ₁₆	
0360 ₁₆	SI/O3 transmit/receive register (S3TRR)	03A0 ₁₆	UART0 transmit/receive mode register (U0MR)
0361 ₁₆		03A1 ₁₆	UART0 bit rate generator (U0BRG)
0362 ₁₆	SI/O3 control register (S3C)	03A2 ₁₆	
0363 ₁₆	SI/O3 bit rate generator (S3BRG)	03A3 ₁₆	UART0 transmit buffer register (U0TB)
0364 ₁₆	SI/O4 transmit/receive register (S4TRR)	03A4 ₁₆	
0365 ₁₆		03A5 ₁₆	UART0 transmit/receive control register 0 (U0C0)
0366 ₁₆	SI/O4 control register (S4C)	03A6 ₁₆	UART0 transmit/receive control register 1 (U0C1)
0367 ₁₆	SI/O4 bit rate generator (S4BRG)	03A7 ₁₆	UART0 receive buffer register (U0RB)
0368 ₁₆		03A8 ₁₆	
0369 ₁₆		03A9 ₁₆	UART1 transmit/receive mode register (U1MR)
036A ₁₆		03AA ₁₆	UART1 bit rate generator (U1BRG)
036B ₁₆		03AB ₁₆	UART1 transmit buffer register (U1TB)
036C ₁₆		03AC ₁₆	UART1 transmit/receive control register 0 (U1C0)
036D ₁₆		03AD ₁₆	UART1 transmit/receive control register 1 (U1C1)
036E ₁₆		03AE ₁₆	
036F ₁₆		03AF ₁₆	UART1 receive buffer register (U1RB)
0370 ₁₆		03B0 ₁₆	UART transmit/receive control register 2 (U2CON)
0371 ₁₆		03B1 ₁₆	
0372 ₁₆		03B2 ₁₆	
0373 ₁₆		03B3 ₁₆	
0374 ₁₆		03B4 ₁₆	Flash identification register (FIDR) (Note1)
0375 ₁₆	UART2 special mode register 3(U2SMR3)	03B5 ₁₆	
0376 ₁₆	UART2 special mode register 2(U2SMR2)	03B6 ₁₆	
0377 ₁₆	UART2 special mode register (U2SMR)	03B7 ₁₆	Flash memory control register 0 (FMR0) (Note1)
0378 ₁₆	UART2 transmit/receive mode register (U2MR)	03B8 ₁₆	DMA0 request cause select register (DM0SL)
0379 ₁₆	UART2 bit rate generator (U2BRG)	03B9 ₁₆	
037A ₁₆		03BA ₁₆	DMA1 request cause select register (DM1SL)
037B ₁₆	UART2 transmit buffer register (U2TB)	03BB ₁₆	
037C ₁₆	UART2 transmit/receive control register 0 (U2C0)	03BC ₁₆	
037D ₁₆	UART2 transmit/receive control register 1 (U2C1)	03BD ₁₆	CRC data register (CRCD)
037E ₁₆		03BE ₁₆	CRC input register (CRCIN)
037F ₁₆	UART2 receive buffer register (U2RB)	03BF ₁₆	

Note 1: This register is only exist in flash memory version.
Note 2: Locations in the SFR area where nothing is allocated are reserved areas. Do not access these areas for read or write.

Figure 1.6.2. Location of peripheral unit control registers (2)

03C0 ₁₆	A-D register 0 (AD0)
03C1 ₁₆	
03C2 ₁₆	A-D register 1 (AD1)
03C3 ₁₆	
03C4 ₁₆	A-D register 2 (AD2)
03C5 ₁₆	
03C6 ₁₆	A-D register 3 (AD3)
03C7 ₁₆	
03C8 ₁₆	A-D register 4 (AD4)
03C9 ₁₆	
03CA ₁₆	A-D register 5 (AD5)
03CB ₁₆	
03CC ₁₆	A-D register 6 (AD6)
03CD ₁₆	
03CE ₁₆	A-D register 7 (AD7)
03CF ₁₆	
03D0 ₁₆	
03D1 ₁₆	
03D2 ₁₆	
03D3 ₁₆	
03D4 ₁₆	A-D control register 2 (ADCON2)
03D5 ₁₆	
03D6 ₁₆	A-D control register 0 (ADCON0)
03D7 ₁₆	A-D control register 1 (ADCON1)
03D8 ₁₆	D-A register 0 (DA0)
03D9 ₁₆	
03DA ₁₆	D-A register 1 (DA1)
03DB ₁₆	
03DC ₁₆	D-A control register (DACON)
03DD ₁₆	
03DE ₁₆	
03DF ₁₆	
03E0 ₁₆	Port P0 (P0)
03E1 ₁₆	Port P1 (P1)
03E2 ₁₆	Port P0 direction register (PD0)
03E3 ₁₆	Port P1 direction register (PD1)
03E4 ₁₆	Port P2 (P2)
03E5 ₁₆	Port P3 (P3)
03E6 ₁₆	Port P2 direction register (PD2)
03E7 ₁₆	Port P3 direction register (PD3)
03E8 ₁₆	Port P4 (P4)
03E9 ₁₆	Port P5 (P5)
03EA ₁₆	Port P4 direction register (PD4)
03EB ₁₆	Port P5 direction register (PD5)
03EC ₁₆	Port P6 (P6)
03ED ₁₆	Port P7 (P7)
03EE ₁₆	Port P6 direction register (PD6)
03EF ₁₆	Port P7 direction register (PD7)
03F0 ₁₆	Port P8 (P8)
03F1 ₁₆	Port P9 (P9)
03F2 ₁₆	Port P8 direction register (PD8)
03F3 ₁₆	Port P9 direction register (PD9)
03F4 ₁₆	Port P10 (P10)
03F5 ₁₆	
03F6 ₁₆	Port P10 direction register (PD10)
03F7 ₁₆	
03F8 ₁₆	
03F9 ₁₆	
03FA ₁₆	
03FB ₁₆	
03FC ₁₆	Pull-up control register 0 (PUR0)
03FD ₁₆	Pull-up control register 1 (PUR1)
03FE ₁₆	Pull-up control register 2 (PUR2)
03FF ₁₆	Port control register (PCR)

Note : Locations in the SFR area where nothing is allocated are reserved areas. Do not access these areas for read or write.

Figure 1.6.3. Location of peripheral unit control registers (3)

Memory Space Expansion Features

Here follows the description of the memory space expansion features.

With the processor running in memory expansion mode or in microprocessor mode, the memory space expansion features provide the means of expanding the accessible space. The memory space expansion features run in one of the three modes given below.

- (1) Normal mode (no expansion)
- (2) Memory space expansion mode (to be referred as expansion mode)

Use bits 5 and 4 (PM15, PM14) of processor mode register 1 to select a desired mode. The external memory area the chip select signal indicates is different in mode so that the accessible memory space varies. Table 1.7.1 shows how to set individual modes and corresponding accessible memory spaces. For external memory area the chip select signal indicates, see Table 1.10.1 on page 31.

Table 1.7.1. The way of setting memory space expansion mode and corresponding memory space

Expansion mode	How to set PM15 and PM14	Accessible memory space
Normal mode (no expansion)	0, 0	Up to 1M byte
Expansion mode	1, 1	Up to 4M bytes

Here follows the description of individual modes.

(1) Normal mode (a mode with memory not expanded)

'Normal mode' means a mode in which memory is not expanded.

Figure 1.7.1 shows the memory maps and the chip select areas in normal mode.

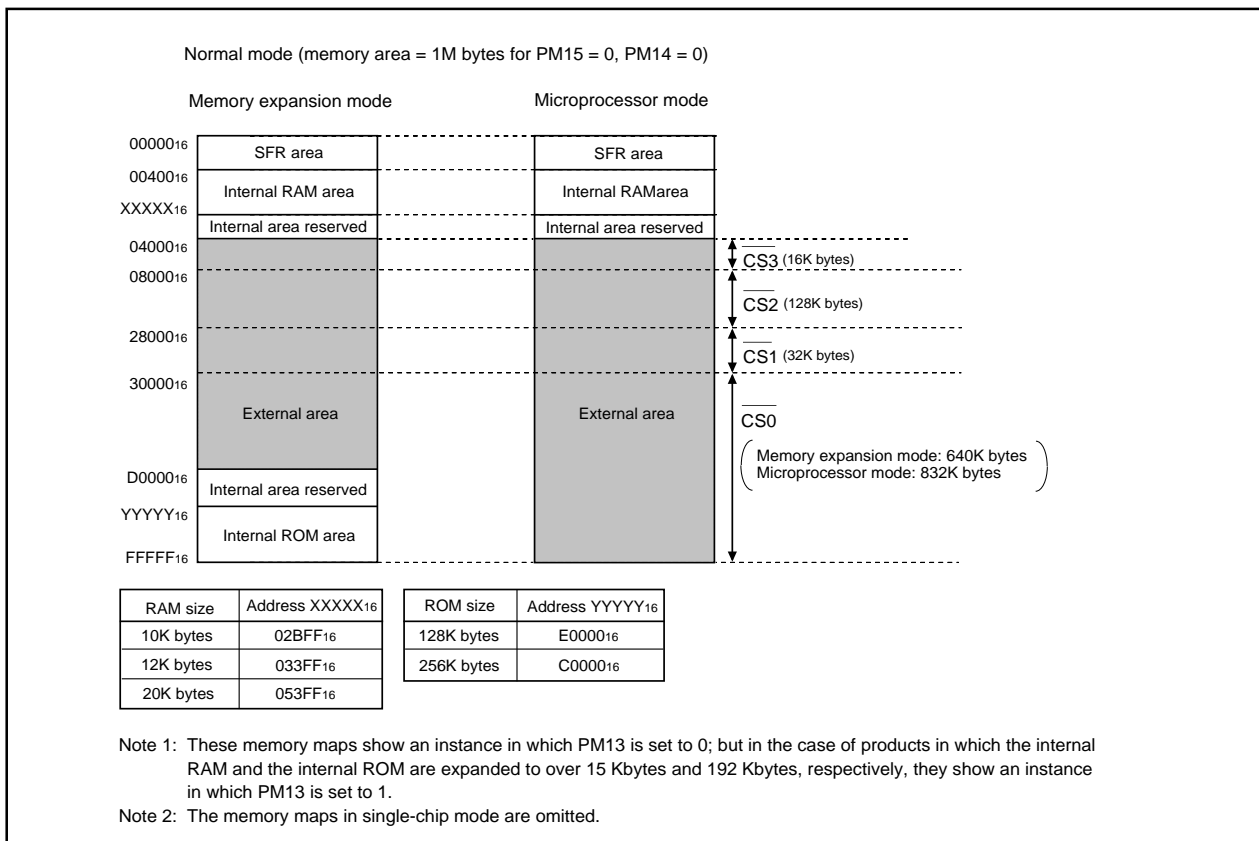

Figure 1.7.1. The memory maps and the chip select areas in normal mode

(2) Expansion mode

In expansion mode, the data bank register (0000B₁₆) goes effective. Figure 1.7.2 shows the data bank register.

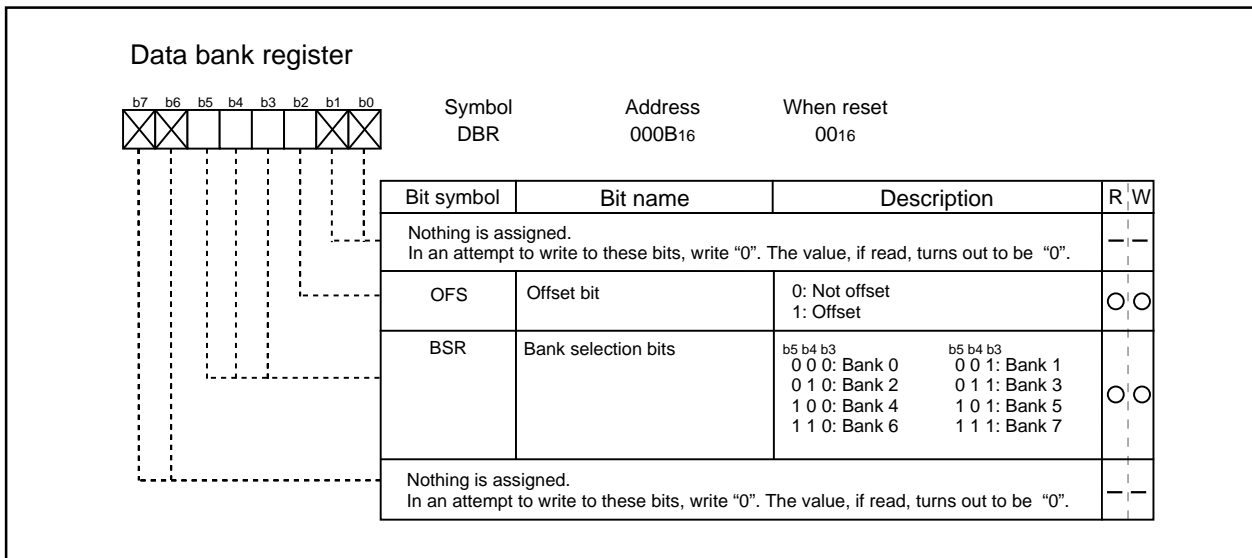

Figure 1.7.2. Data bank register

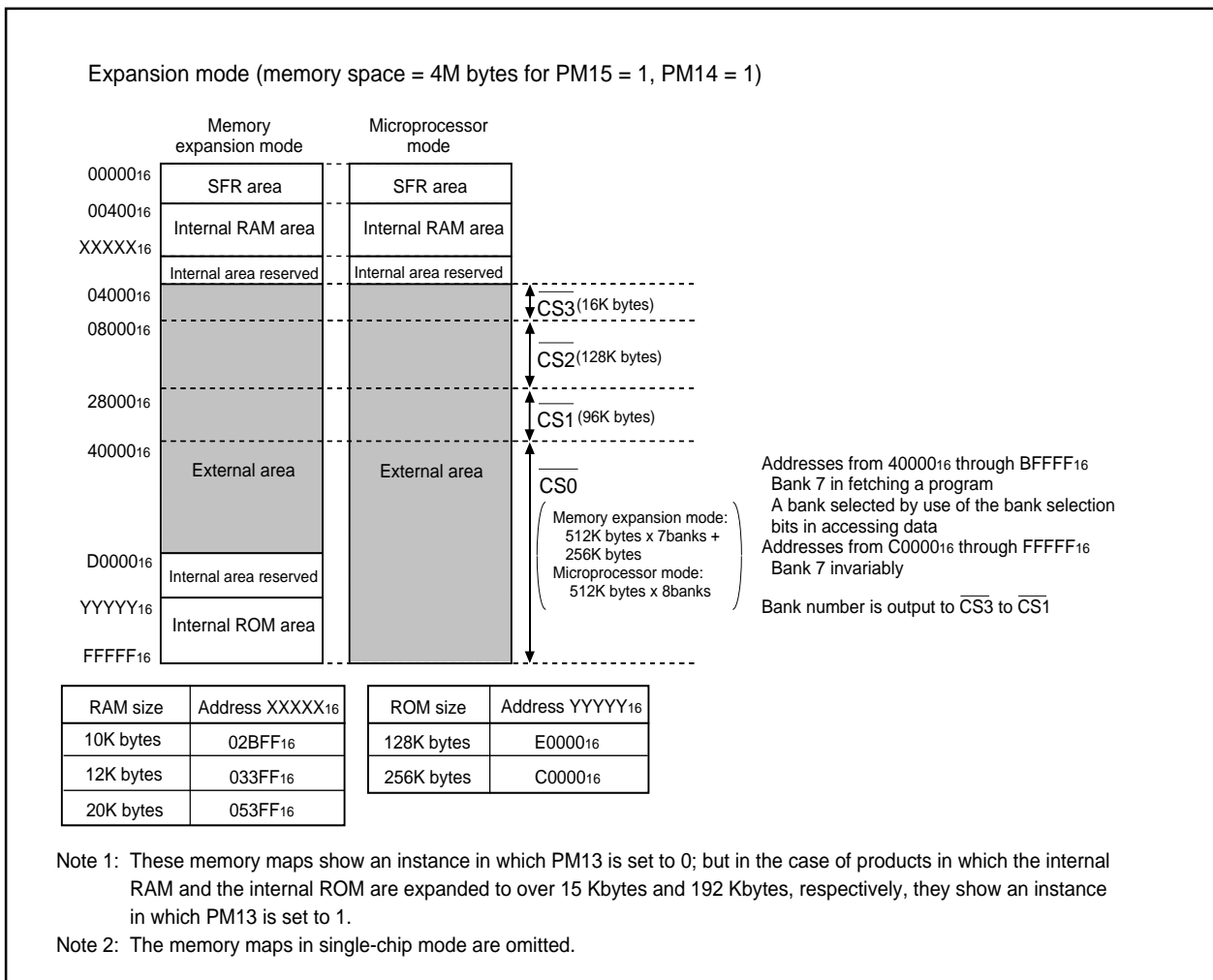

Figure 1.7.3. Memory location and chip select area in expansion mode 2

The data bank register is made up of the bank selection bits (bits 5 through 3) and the offset bit (bit 2). The bank selection bits are used to set a bank number for accessing data lying between 40000₁₆ and BFFFF₁₆. Assigning 1 to the offset bit provides the means to set offsets covering 40000₁₆.

Figure 1.7.3 shows the memory location and chip select areas in expansion mode.

The area relevant to $\overline{CS0}$ ranges from 40000₁₆ through FFFFF₁₆. As for the area from 40000₁₆ through BFFFF₁₆, the bank number set by use of the bank selection bits are output from the output terminals $\overline{CS3}$ - $\overline{CS1}$ only in accessing data. In fetching a program, bank 7 (111₂) is output from $\overline{CS3}$ - $\overline{CS1}$. As for the area from C0000₁₆ through FFFFF₁₆, bank 7 (111₂) is output from $\overline{CS3}$ - $\overline{CS1}$ without regard to accessing data or to fetching a program.

In accessing an area irrelevant to $\overline{CS0}$, a chip select signal $\overline{CS3}$ (4000₁₆ - 7FFF₁₆), $\overline{CS2}$ (8000₁₆ - 27FFF₁₆), and $\overline{CS1}$ (28000₁₆ - 3FFFF₁₆) is output depending on the address as in the past.

Figure 1.7.4 shows an example of connecting the MCU with a 4-M byte ROM and to a 128-K byte SRAM. Connect the chip select of 4-M byte ROM with $\overline{CS0}$. Connect M16C's $\overline{CS3}$, $\overline{CS2}$, and $\overline{CS1}$ with address inputs AD21, AD20, and AD19 respectively. Connect M16C's output A19 with address input AD18. Figure 1.7.5 shows the relationship between addresses of the 4-M byte ROM and those of M16C.

In this mode, memory is banked every 512 K bytes, so that data access in different banks requires switching over banks. However, data on bank boundaries when offset bit = 0 can be accessed successively by setting the offset bit to 1, because in which case the memory address is offset by 40000₁₆. For example, two bytes of data located at addresses 0FFFF₁₆ and 100000₁₆ of 4-Mbyte ROM can be accessed successively without having to change the bank bit by setting the offset bit to 1 and then accessing addresses 07FFF₁₆ and 800000₁₆.

On the other hand, the SRAM's chip select assumes that $\overline{CS0}=1$ (not selected) and $\overline{CS2}=0$ (selected), so connect $\overline{CS0}$ with S2 and $\overline{CS2}$ with S1. If the SRAM doesn't have a bipolar chip select input terminal, decode $\overline{CS0}$ and $\overline{CS2}$ externally.

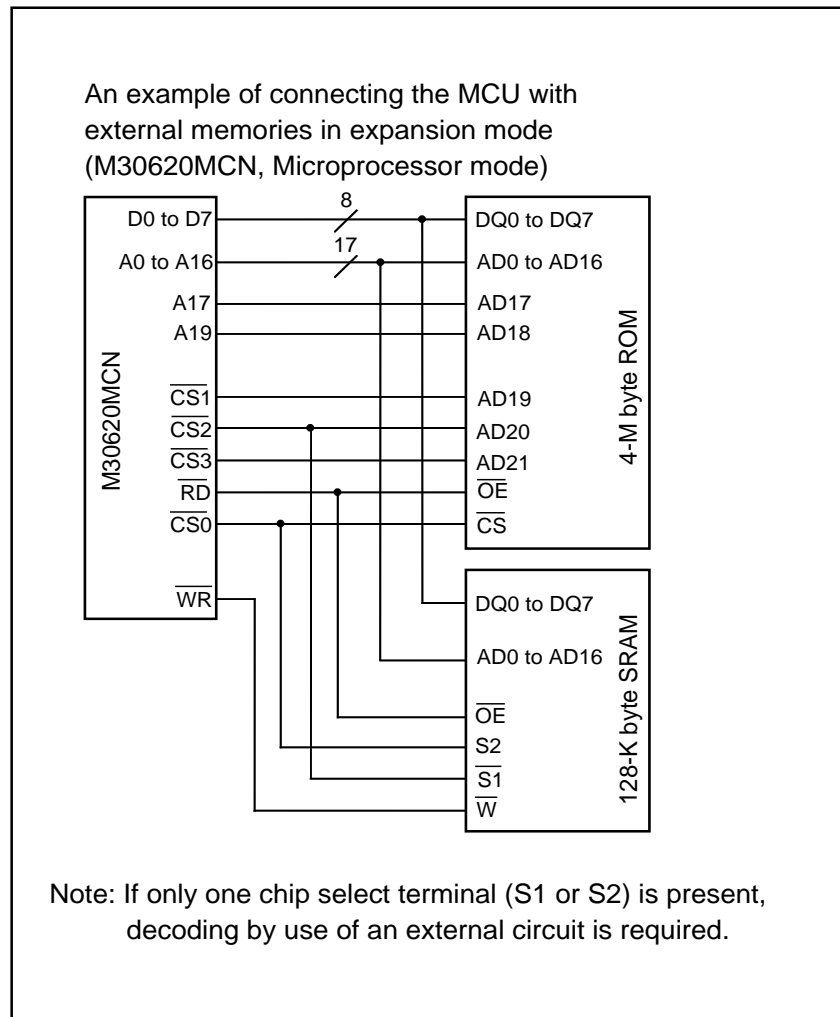

Figure 1.7.4. An example of connecting the MCU with external memories in expansion mode

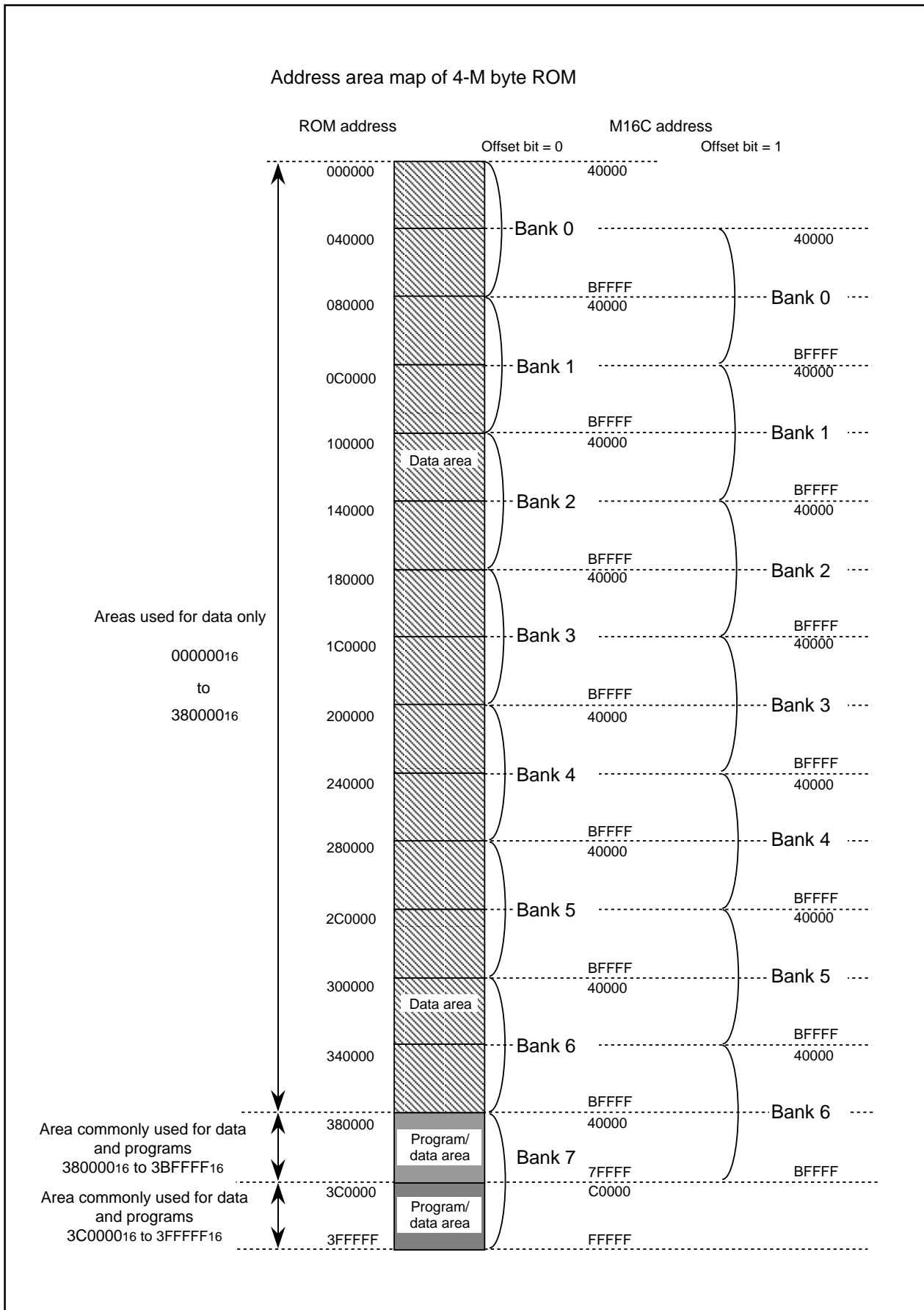

Figure 1.7.5. Relationship between addresses on 4-M byte ROM and those on M16C

Software Reset

Writing “1” to bit 3 of the processor mode register 0 (address 000416) applies a (software) reset to the microcomputer. A software reset has the same effect as a hardware reset. The contents of internal RAM are preserved.

Processor Mode

(1) Types of Processor Mode

One of three processor modes can be selected: single-chip mode, memory expansion mode, and microprocessor mode. The functions of some pins, the memory map, and the access space differ according to the selected processor mode.

- **Single-chip mode**

In single-chip mode, only internal memory space (SFR, internal RAM, and internal ROM) can be accessed. However, after the reset has been released and the operation of shifting from the microprocessor mode has started (“H” applied to the CNVss pin), the internal ROM area cannot be accessed even if the CPU shifts to the single-chip mode.

Ports P0 to P10 can be used as programmable I/O ports or as I/O ports for the internal peripheral functions.

- **Memory expansion mode**

In memory expansion mode, external memory can be accessed in addition to the internal memory space (SFR, internal RAM, and internal ROM). However, after the reset has been released and the operation of shifting from the microprocessor mode has started (“H” applied to the CNVss pin), the internal ROM area cannot be accessed even if the CPU shifts to the memory expansion mode.

In this mode, some of the pins function as the address bus, the data bus, and as control signals. The number of pins assigned to these functions depends on the bus and register settings. (See “Bus Settings” for details.)

- **Microprocessor mode**

In microprocessor mode, the SFR, internal RAM, and external memory space can be accessed. The internal ROM area cannot be accessed.

In this mode, some of the pins function as the address bus, the data bus, and as control signals. The number of pins assigned to these functions depends on the bus width and register settings. (See “Bus Settings” for details.)

In the memory expansion and microprocessor modes, the addressable space can be expanded by using the memory space expansion features. (See “Memory Space Expansion Features” for details.)

(2) Setting Processor Modes

The processor mode is set using the CNVss pin and the processor mode bits (bits 1 and 0 at address 000416). Do not set the processor mode bits to “102”.

Regardless of the level of the CNVss pin, changing the processor mode bits selects the mode. Therefore, never change the processor mode bits when changing the contents of other bits. Do not change the processor mode bits simultaneously with other bits when changing the processor mode bits “012” or “112”. Change the processor mode bits after changing the other bits. Also do not attempt to shift to or from the microprocessor mode within the program stored in the internal ROM area.

- **Applying Vss to CNVss pin**

The microcomputer begins operation in single-chip mode after being reset. Memory expansion mode is selected by writing “012” to the processor mode bits.

- **Applying Vcc to CNVss pin**

The microcomputer starts to operate in microprocessor mode after being reset.

Figure 1.8.1 shows the processor mode register 0 and 1.

Figure 1.8.2 shows the memory maps in each processor mode (without memory area expansion, normal mode).

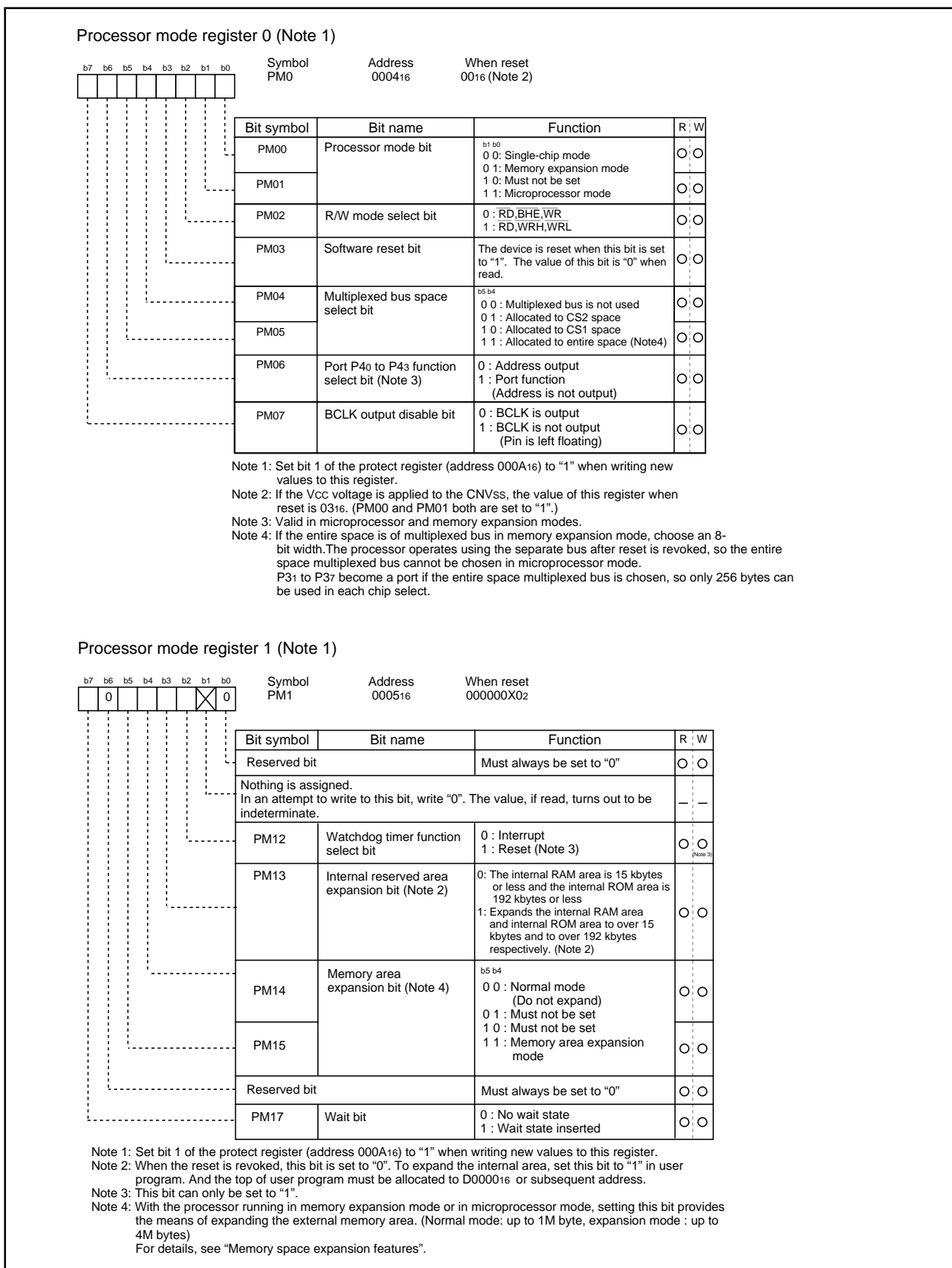

Figure 1.8.1. Processor mode register 0 and 1

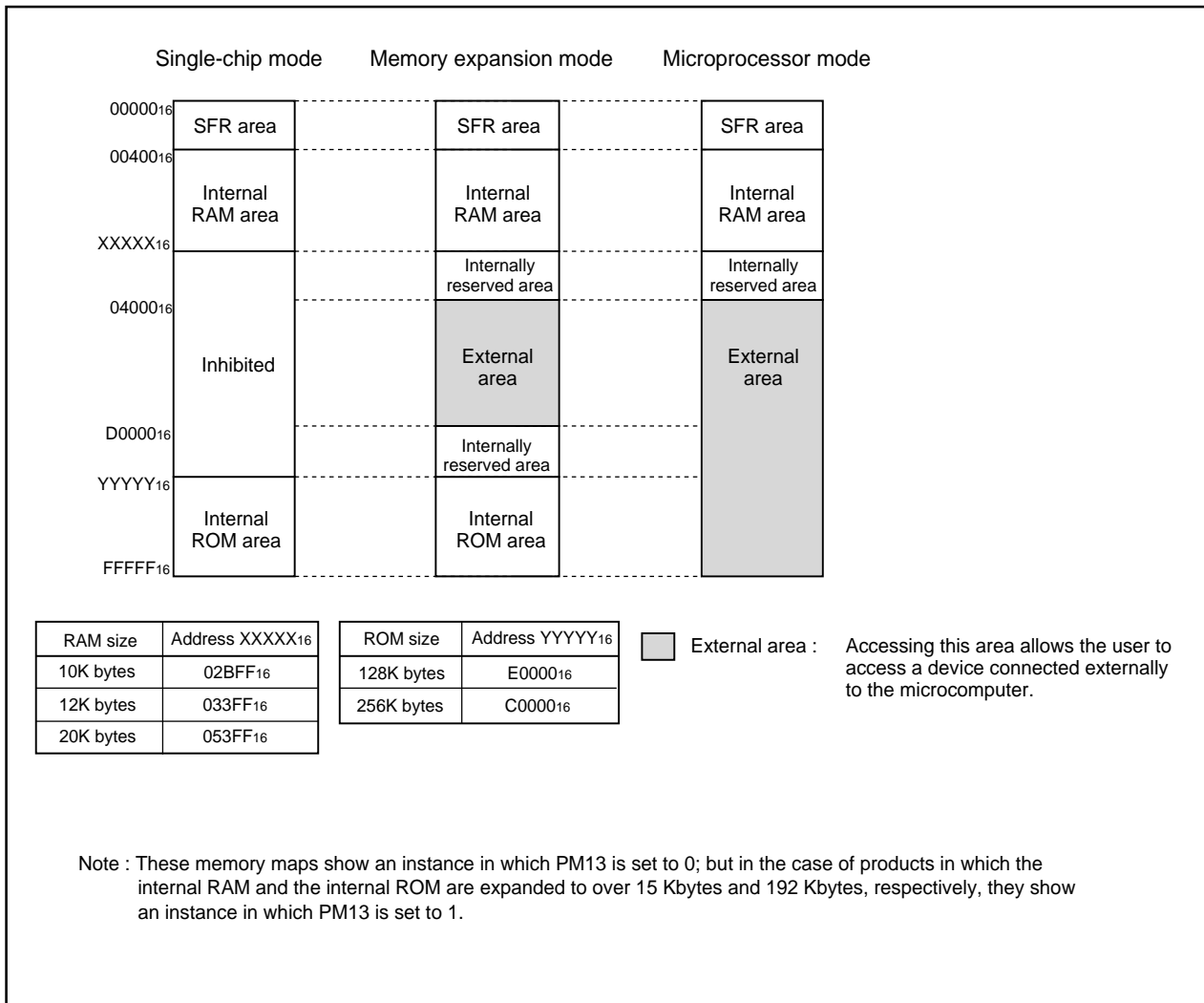

Figure 1.8.2. Memory maps in each processor mode (without memory area expansion, normal mode)

Internal Reserved Area Expansion Bit (PM13)

This bit expands the internal RAM area and the internal ROM area, and changes the chip select area. In M30624FGN, for example, to set this bit to “1” expands the internal RAM area and the internal ROM area to 20 Kbytes and 256 Kbytes respectively. Refer to Figure 1.8.3 for the chip select area. When the reset is revoked, this bit is set to “0”. To expand the internal area, set this bit to “1” in user program. And the top of user program must be allocated to D0000₁₆ or subsequent address.

In the case of the product in which the internal ROM is 192 Kbytes or less and the internal RAM is 15 Kbytes or less, set this bit to “0” when this product is used in the memory expansion mode or the microprocessor mode. When the product is used in the single chip mode, the internal area is not expanded and any action is not affected, even if this bit is set to “1”.

Figure 1.8.3 shows the memory maps and the chip selection areas effected by PM13 (the internal reserved area expansion bit) in each processor mode for the product having an internal RAM of more than 15K bytes and a ROM of more than 192K bytes.

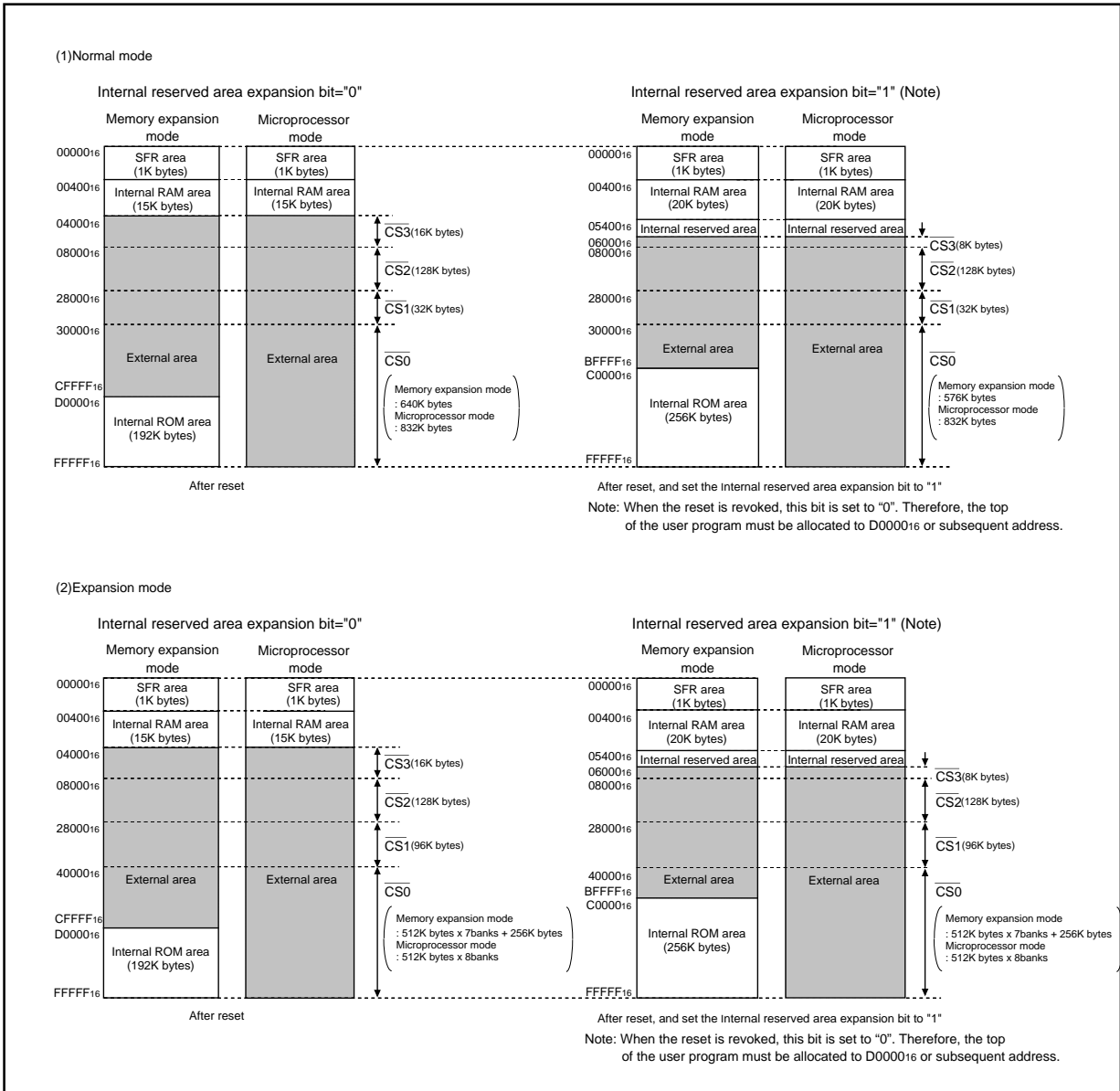

Figure 1.8.3. Memory location and chip select area in each processor mode

Bus Settings

The BYTE pin and bits 4 to 6 of the processor mode register 0 (address 000416) are used to change the bus settings.

Table 1.9.1 shows the factors used to change the bus settings.

Table 1.9.1. Factors for switching bus settings

Bus setting	Switching factor
Switching external address bus width	Bit 6 of processor mode register 0
Switching external data bus width	BYTE pin
Switching between separate and multiplex bus	Bits 4 and 5 of processor mode register 0

(1) Selecting external address bus width

The address bus width for external output in the 1M bytes of address space can be set to 16 bits (64K bytes address space) or 20 bits (1M bytes address space). When bit 6 of the processor mode register 0 is set to "1", the external address bus width is set to 16 bits, and P2 and P3 become part of the address bus. P40 to P43 can be used as programmable I/O ports. When bit 6 of processor mode register 0 is set to "0", the external address bus width is set to 20 bits, and P2, P3, and P40 to P43 become part of the address bus.

(2) Selecting external data bus width

The external data bus width can be set to 8 or 16 bits. (Note, however, that only the separate bus can be set.) When the BYTE pin is "L", the bus width is set to 16 bits; when "H", it is set to 8 bits. (The internal bus width is permanently set to 16 bits.) While operating, fix the BYTE pin either to "H" or to "L".

(3) Selecting separate/multiplex bus

The bus format can be set to multiplex or separate bus using bits 4 and 5 of the processor mode register 0.

• Separate bus

In this mode, the data and address are input and output separately. The data bus can be set using the BYTE pin to be 8 or 16 bits. When the BYTE pin is "H", the data bus is set to 8 bits and P0 functions as the data bus and P1 as a programmable I/O port. When the BYTE pin is "L", the data bus is set to 16 bits and P0 and P1 are both used for the data bus.

When the separate bus is used for access, a software wait can be selected.

• Multiplex bus

In this mode, data and address I/O are time multiplexed. With the BYTE pin = "H", the 8 bits from D0 to D7 are multiplexed with A0 to A7.

With the BYTE pin = "L", the 8 bits from D0 to D7 are multiplexed with A1 to A8. D8 to D15 are not multiplexed. In this case, the external devices connected to the multiplexed bus are mapped to the microcomputer's even addresses (every 2nd address). To access these external devices, access the even addresses as bytes.

The ALE signal latches the address. It is output from P56.

Before using the multiplex bus for access, be sure to insert a software wait.

If the entire space is of multiplexed bus in memory expansion mode, choose an 8-bit width.

The processor operates using the separate bus after reset is revoked, so the entire space multiplexed bus cannot be chosen in microprocessor mode.

P31 to P37 become a port if the entire space multiplexed bus is chosen, so only 256 bytes can be used in each chip select.

Table 1.9.2. Pin functions for each processor mode

Processor mode	Single-chip mode	Memory expansion mode/microprocessor modes				Memory expansion mode
Multiplexed bus space select bit		"01", "10" [Either CS1 or CS2 is for multiplexed bus and others are for separate bus]		"00" (separate bus)		"11" (Note 1) [multiplexed bus for the entire space]
Data bus width BYTE pin level		8 bits "H"	16 bits "L"	8 bits "H"	16 bits "L"	8 bit "H"
P00 to P07	I/O port	Data bus	Data bus	Data bus	Data bus	I/O port
P10 to P17	I/O port	I/O port	Data bus	I/O port	Data bus	I/O port
P20	I/O port	Address bus /data bus(Note 2)	Address bus	Address bus	Address bus	Address bus /data bus
P21 to P27	I/O port	Address bus /data bus(Note 2)	Address bus /data bus(Note 2)	Address bus	Address bus	Address bus /data bus
P30	I/O port	Address bus	Address bus /data bus(Note 2)	Address bus	Address bus	A8/D7
P31 to P37	I/O port	Address bus	Address bus	Address bus	Address bus	I/O port
P40 to P43 Port P40 to P43 function select bit = 1	I/O port	I/O port	I/O port	I/O port	I/O port	I/O port
P40 to P43 Port P40 to P43 function select bit = 0	I/O port	Address bus	Address bus	Address bus	Address bus	I/O port
P44 to P47	I/O port	\overline{CS} (chip select) or programmable I/O port (For details, refer to "Bus control")				
P50 to P53	I/O port	Outputs \overline{RD} , \overline{WRL} , \overline{WRH} , and \overline{BCLK} or \overline{RD} , \overline{BHE} , \overline{WR} , and \overline{BCLK} (For details, refer to "Bus control")				
P54	I/O port	\overline{HLDA}	\overline{HLDA}	\overline{HLDA}	\overline{HLDA}	\overline{HLDA}
P55	I/O port	\overline{HOLD}	\overline{HOLD}	\overline{HOLD}	\overline{HOLD}	\overline{HOLD}
P56	I/O port	ALE	ALE	ALE	ALE	ALE
P57	I/O port	\overline{RDY}	\overline{RDY}	\overline{RDY}	\overline{RDY}	\overline{RDY}

Note 1: If the entire space is of multiplexed bus in memory expansion mode, choose an 8-bit width.

The processor operates using the separate bus after reset is revoked, so the entire space multiplexed bus cannot be chosen in microprocessor mode.

P31 to P37 become a port if the entire space multiplexed bus is chosen, so only 256 bytes can be used in each chip select.

Note 2: Address bus when in separate bus mode.

Bus Control

The following explains the signals required for accessing external devices and software waits. The signals required for accessing the external devices are valid when the processor mode is set to memory expansion mode and microprocessor mode. The software waits are valid in all processor modes.

(1) Address bus/data bus

The address bus consists of the 20 pins A0 to A19 for accessing the 1M bytes of address space.

The data bus consists of the pins for data I/O. When the BYTE pin is "H", the 8 ports D0 to D7 function as the data bus. When BYTE is "L", the 16 ports D0 to D15 function as the data bus.

When a change is made from single-chip mode to memory expansion mode, the value of the address bus is undefined until external memory is accessed.

(2) Chip select signal

The chip select signal is output using the same pins as P44 to P47. Bits 0 to 3 of the chip select control register (address 0008₁₆) set each pin to function as a port or to output the chip select signal. The chip select control register is valid in memory expansion mode and microprocessor mode. In single-chip mode, P44 to P47 function as programmable I/O ports regardless of the value in the chip select control register.

In microprocessor mode, only $\overline{CS0}$ outputs the chip select signal after the reset state has been cancelled. $\overline{CS1}$ to $\overline{CS3}$ function as input ports. Figure 1.10.1 shows the chip select control register.

The chip select signal can be used to split the external area into as many as four blocks. Tables 1.10.1 and 1.10.2 show the external memory areas specified using the chip select signal.

Table 1.10.1. External areas specified by the chip select signals

(A product having an internal RAM equal to or less than 15K bytes and a ROM equal to or less than 192K bytes)(Note)

Memory space expansion mode		Processor mode	Chip select signal			
			$\overline{CS0}$	$\overline{CS1}$	$\overline{CS2}$	$\overline{CS3}$
Specified address range	Normal mode (PM15,14=0,0)	Memory expansion mode	30000 ₁₆ to CFFFF ₁₆ (640K bytes)	28000 ₁₆ to 2FFFF ₁₆ (32K bytes)	08000 ₁₆ to 27FFF ₁₆ (128K bytes)	04000 ₁₆ to 07FFF ₁₆ (16K bytes)
		Microprocessor mode	30000 ₁₆ to FFFFF ₁₆ (832K bytes)			
Expansion mode (PM15,14=1,1)	Memory expansion mode	40000 ₁₆ to BFFFF ₁₆ (512K bytes X 7 + 256K bytes)	28000 ₁₆ to 3FFFF ₁₆ (96K bytes)			
	Microprocessor mode	40000 ₁₆ to FFFFF ₁₆ (512K bytes X 8)				

Note :Be sure to set bit 3 (PM13) of processor mode register 1 to "0".

Table 1.10.2. External areas specified by the chip select signals

(A product having an internal RAM of more than 15K bytes and a ROM of more than 192K bytes)

Memory space expansion mode	Processor mode	Chip select signal			
		$\overline{CS0}$	$\overline{CS1}$	$\overline{CS2}$	$\overline{CS3}$
Specified address range	Normal mode (PM15,14=0,0)	Memory expansion mode	28000 ₁₆ to 2FFFF ₁₆ (32K bytes)	08000 ₁₆ to 27FFF ₁₆ (128K bytes)	When PM13=0 04000 ₁₆ to 07FFF ₁₆ (16K bytes)
		Microprocessor mode			
Expansion mode (PM15,14=1,1)	Memory expansion mode	Microprocessor mode	28000 ₁₆ to 3FFFF ₁₆ (96K bytes)	08000 ₁₆ to 27FFF ₁₆ (128K bytes)	When PM13=1 06000 ₁₆ to 07FFF ₁₆ (8K bytes)
		Microprocessor mode			
Expansion mode (PM15,14=1,1)	Memory expansion mode	Microprocessor mode	28000 ₁₆ to 3FFFF ₁₆ (96K bytes)	08000 ₁₆ to 27FFF ₁₆ (128K bytes)	When PM13=1 06000 ₁₆ to 07FFF ₁₆ (8K bytes)
		Microprocessor mode			
Expansion mode (PM15,14=1,1)	Memory expansion mode	Microprocessor mode	28000 ₁₆ to 3FFFF ₁₆ (96K bytes)	08000 ₁₆ to 27FFF ₁₆ (128K bytes)	When PM13=1 06000 ₁₆ to 07FFF ₁₆ (8K bytes)
		Microprocessor mode			

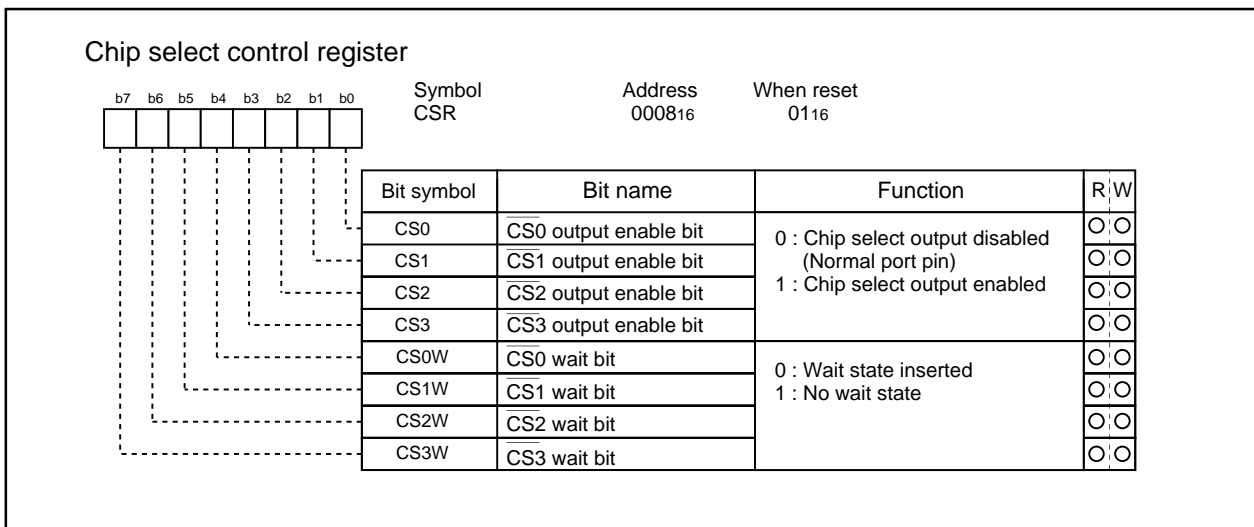
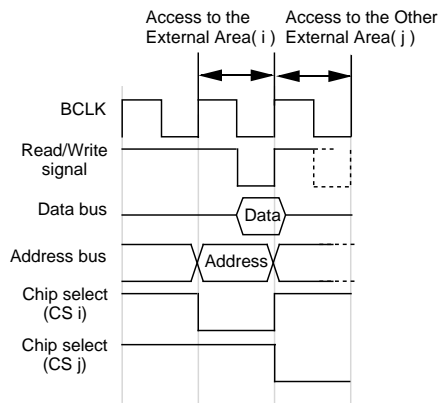

Figure 1.10.1. Chip select control register

The timing of the chip select signal changing to “L”(active) is synchronized with the address bus. But the timing of the chip select signal changing to “H” depends on the area which will be accessed in the next cycle. Figure 1.10.2 shows the output example of the address bus and chip select signal.

Example 1) After access the external area, both the address signal and the chip select signal change concurrently in the next cycle.

In this example, after access to the external area(i), an access to the area indicated by the other chip select signal(j) will occur in the next cycle. In this case, both the address bus and the chip select signal change between the two cycles.



Example 2) After access the external area, only the chip select signal changes in the next cycle (the address bus does not change).

In this example, an access to the internal ROM or the internal RAM in the next cycle will occur, after access to the external area. In this case, the chip select signal changes between the two cycles, but the address does not change.

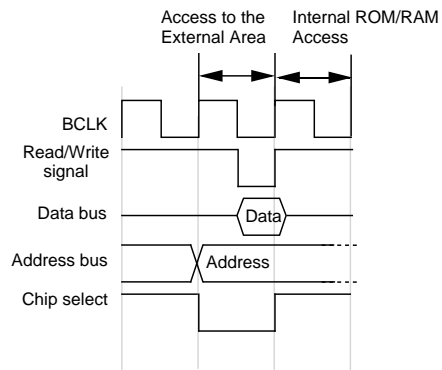

Example 3) After access the external area, only the address bus changes in the next cycle (the chip select signal does not change).

In this example, after access to the external area(i), an access to the area indicated by the same chip select signal(i) will occur in the next cycle. In this case, the address bus changes between the two cycles, but the chip select signal does not change.

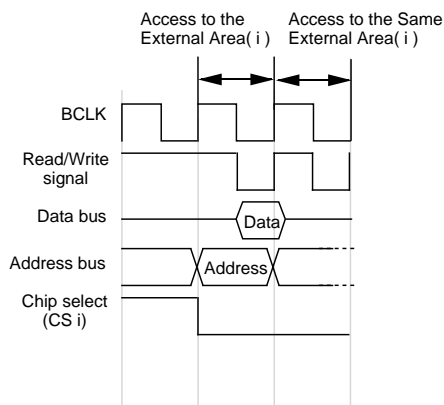

Example 4) After access the external area, either the address signal and the chip select signal do not change in the next cycle.

In this example, any access to any area does not occur in the next cycle (either instruction prefetch does not occur). In this case, either the address bus and chip select signal do not change between the two cycles.

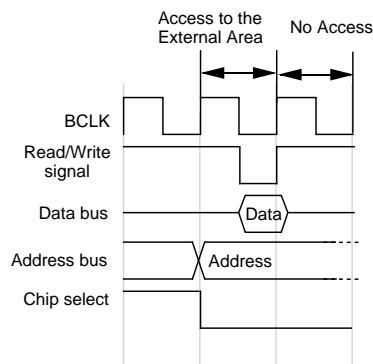

Note : These examples show the address bus and chip select signal within the successive two cycles. According to the combination of these examples, the chip select can be elongated to over 2cycles.

Figure 1.10.2. Output Examples about Address Bus and Chip Select Signal (Separated Bus without Wait)

(3) Read/write signals

With a 16-bit data bus (BYTE pin = "L"), bit 2 of the processor mode register 0 (address 0004₁₆) select the combinations of \overline{RD} , \overline{BHE} , and \overline{WR} signals or \overline{RD} , \overline{WRL} , and \overline{WRH} signals. With an 8-bit data bus (BYTE pin = "H"), use the combination of \overline{RD} , \overline{WR} , and \overline{BHE} signals. (Set bit 2 of the processor mode register 0 (address 0004₁₆) to "0".) Tables 1.10.3 and 1.10.4 show the operation of these signals.

After a reset has been cancelled, the combination of \overline{RD} , \overline{WR} , and \overline{BHE} signals is automatically selected. When switching to the \overline{RD} , \overline{WRL} , and \overline{WRH} combination, do not write to external memory until bit 2 of the processor mode register 0 (address 0004₁₆) has been set (Note).

Note: Before attempting to change the contents of the processor mode register 0, set bit 1 of the protect register (address 000A₁₆) to "1".

Table 1.10.3. Operation of \overline{RD} , \overline{WRL} , and \overline{WRH} signals

Data bus width	\overline{RD}	\overline{WRL}	\overline{WRH}	Status of external data bus
16-bit (BYTE = "L")	L	H	H	Read data
	H	L	H	Write 1 byte of data to even address
	H	H	L	Write 1 byte of data to odd address
	H	L	L	Write data to both even and odd addresses

Table 1.10.4. Operation of \overline{RD} , \overline{WR} , and \overline{BHE} signals

Data bus width	\overline{RD}	\overline{WR}	\overline{BHE}	A0	Status of external data bus
16-bit (BYTE = "L")	H	L	L	H	Write 1 byte of data to odd address
	L	H	L	H	Read 1 byte of data from odd address
	H	L	H	L	Write 1 byte of data to even address
	L	H	H	L	Read 1 byte of data from even address
	H	L	L	L	Write data to both even and odd addresses
	L	H	L	L	Read data from both even and odd addresses
8-bit (BYTE = "H")	H	L	Not used	H / L	Write 1 byte of data
	L	H	Not used	H / L	Read 1 byte of data

(4) ALE signal

The ALE signal latches the address when accessing the multiplex bus space. Latch the address when the ALE signal falls.

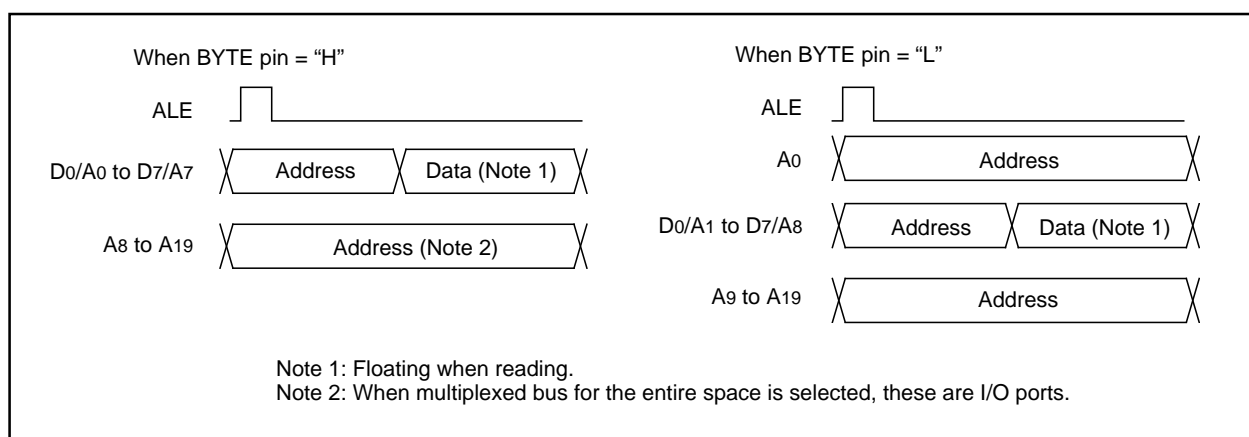

Figure 1.10.3. ALE signal and address/data bus

(5) The \overline{RDY} signal

\overline{RDY} is a signal that facilitates access to an external device that requires long access time. As shown in Figure 1.10.4, if an “L” is being input to the \overline{RDY} at the BCLK falling edge, the bus turns to the wait state. If an “H” is being input to the \overline{RDY} pin at the BCLK falling edge, the bus cancels the wait state. Table 1.10.5 shows the state of the microcomputer with the bus in the wait state, and Figure 1.10.4 shows an example in which the \overline{RD} signal is prolonged by the \overline{RDY} signal.

The \overline{RDY} signal is valid when accessing the external area during the bus cycle in which bits 4 to 7 of the chip select control register (address 000816) are set to “0”. The \overline{RDY} signal is invalid when setting “1” to all bits 4 to 7 of the chip select control register (address 000816), but the \overline{RDY} pin should be treated as properly as in non-using.

Table 1.10.5. Microcomputer status in wait state (Note)

Item	Status
Oscillation	On
R/W signal, address bus, data bus, \overline{CS} ALE signal, \overline{HLDA} , programmable I/O ports	Maintain status when \overline{RDY} signal received
Internal peripheral circuits	On

Note: The \overline{RDY} signal cannot be received immediately prior to a software wait.

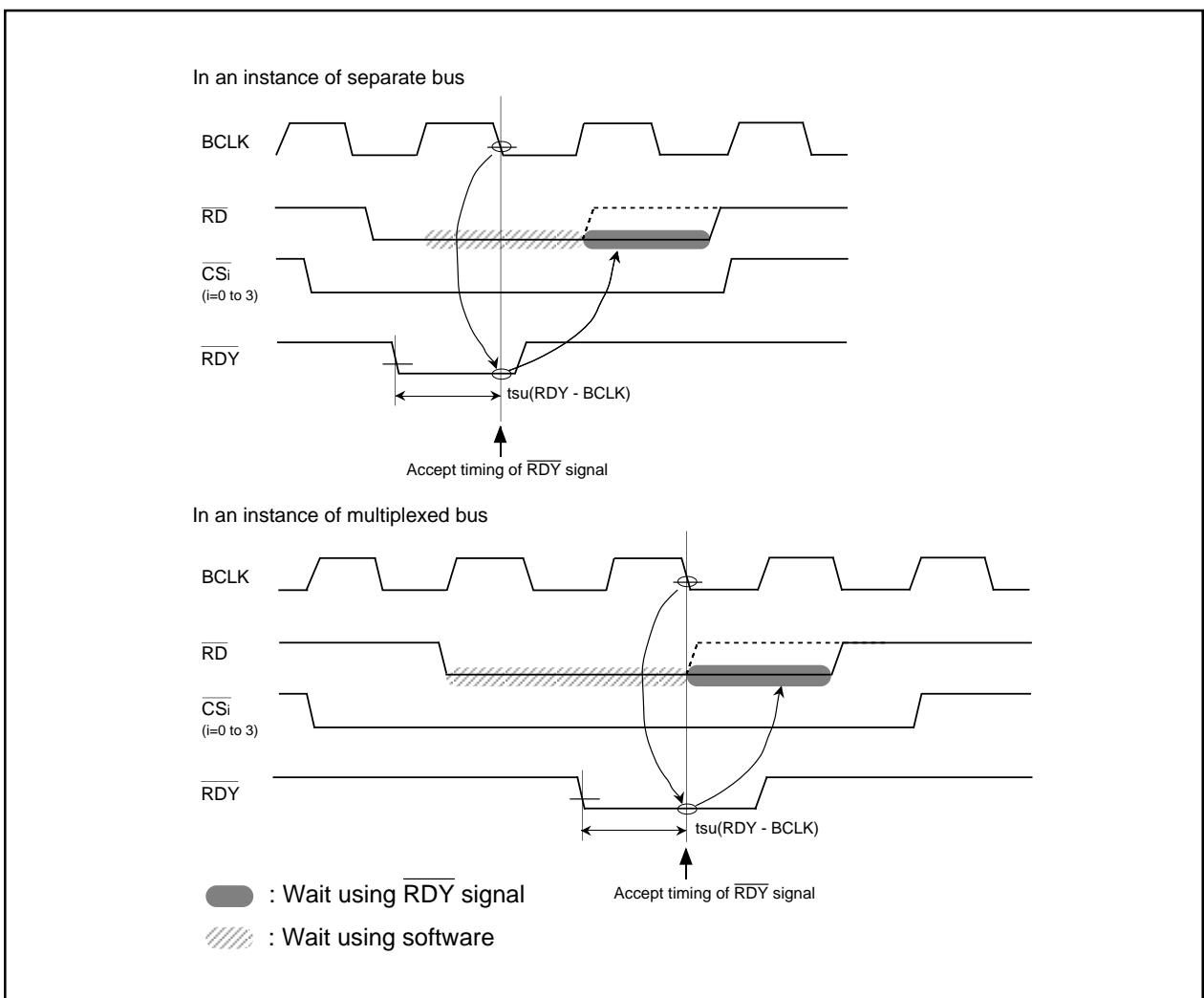

Figure 1.10.4. Example of \overline{RD} signal extended by \overline{RDY} signal

(6) Hold signal

The hold signal is used to transfer the bus privileges from the CPU to the external circuits. Inputting "L" to the $\overline{\text{HOLD}}$ pin places the microcomputer in the hold state at the end of the current bus access. This status is maintained and "L" is output from the $\overline{\text{HLDA}}$ pin as long as "L" is input to the $\overline{\text{HOLD}}$ pin. Table 1.10.6 shows the microcomputer status in the hold state.

Bus-using priorities are given to $\overline{\text{HOLD}}$, DMAC, and CPU in order of decreasing precedence.

$\overline{\text{HOLD}} > \text{DMAC} > \text{CPU}$

Figure 1.10.5. Bus-using priorities**Table 1.10.6. Microcomputer status in hold state**

Item		Status
Oscillation		ON
R/ $\overline{\text{W}}$ signal, address bus, data bus, $\overline{\text{CS}}$, $\overline{\text{BHE}}$		Floating
Programmable I/O ports	P0, P1, P2, P3, P4, P5	Floating
	P6, P7, P8, P9, P10	Maintains status when hold signal is received
$\overline{\text{HLDA}}$		Output "L"
Internal peripheral circuits		ON (but watchdog timer stops)
ALE signal		Undefined

(7) External bus status when the internal area is accessed

Table 1.10.7 shows the external bus status when the internal area is accessed.

Table 1.10.7. External bus status when the internal area is accessed

Item		SFR accessed	Internal ROM/RAM accessed
Address bus		Address output	Maintain status before accessed address of external area
Data bus	When read	Floating	Floating
	When write	Output data	Undefined
$\overline{\text{RD}}$, $\overline{\text{WR}}$, $\overline{\text{WRL}}$, $\overline{\text{WRH}}$		$\overline{\text{RD}}$, $\overline{\text{WR}}$, $\overline{\text{WRL}}$, $\overline{\text{WRH}}$ output	Output "H"
$\overline{\text{BHE}}$		$\overline{\text{BHE}}$ output	Maintain status before accessed status of external area
$\overline{\text{CS}}$		Output "H"	Output "H"
ALE		Output "L"	Output "L"

(8) BCLK output

The user can choose the BCLK output by use of bit 7 of processor mode register 0 (0004₁₆) (Note). When set to "1", the output floating.

Note: Before attempting to change the contents of the processor mode register 0, set bit 1 of the protect register (address 000A₁₆) to "1".

(9) Software wait

A software wait can be inserted by setting the wait bit (bit 7) of the processor mode register 1 (address 0005₁₆) (Note) and bits 4 to 7 of the chip select control register (address 0008₁₆).

A software wait is inserted in the internal ROM/RAM area and in the external memory area by setting the wait bit of the processor mode register 1. When set to "0", each bus cycle is executed in one BCLK cycle. When set to "1", each bus cycle is executed in two or three BCLK cycles. After the microcomputer has been reset, this bit defaults to "0". When set to "1", a wait is applied to all memory areas (two or three BCLK cycles), regardless of the contents of bits 4 to 7 of the chip select control register. Set this bit after referring to the recommended operating conditions (main clock input oscillation frequency) of the electric characteristics. However, when the user is using the $\overline{\text{RDY}}$ signal, the relevant bit in the chip select control register's bits 4 to 7 must be set to "0".

When the wait bit of the processor mode register 1 is "0", software waits can be set independently for each of the 4 areas selected using the chip select signal. Bits 4 to 7 of the chip select control register correspond to chip selects $\overline{\text{CS0}}$ to $\overline{\text{CS3}}$. When one of these bits is set to "1", the bus cycle is executed in one BCLK cycle. When set to "0", the bus cycle is executed in two or three BCLK cycles. These bits default to "0" after the microcomputer has been reset.

The SFR area is always accessed in two BCLK cycles regardless of the setting of these control bits. Also, insert a software wait if using the multiplex bus to access the external memory area.

Table 1.10.8 shows the software wait and bus cycles. Figure 1.10.6 shows example of bus timing when using software waits.

Note: Before attempting to change the contents of the processor mode register 1, set bit 1 of the protect register (address 000A₁₆) to "1".

Table 1.10.8. Software waits and bus cycles

Area	Bus status	Wait bit	Bits 4 to 7 of chip select control register	Bus cycle
SFR	———	Invalid	Invalid	2 BCLK cycles
Internal ROM/RAM	———	0	Invalid	1 BCLK cycle
	———	1	Invalid	2 BCLK cycles
External memory area	Separate bus	0	1	1 BCLK cycle
	Separate bus	0	0	2 BCLK cycles
	Separate bus	1	0 (Note)	2 BCLK cycles
	Multiplex bus	0	0	3 BCLK cycles
	Multiplex bus	1	0 (Note)	3 BCLK cycles

Note: When using the $\overline{\text{RDY}}$ signal, always set to "0".

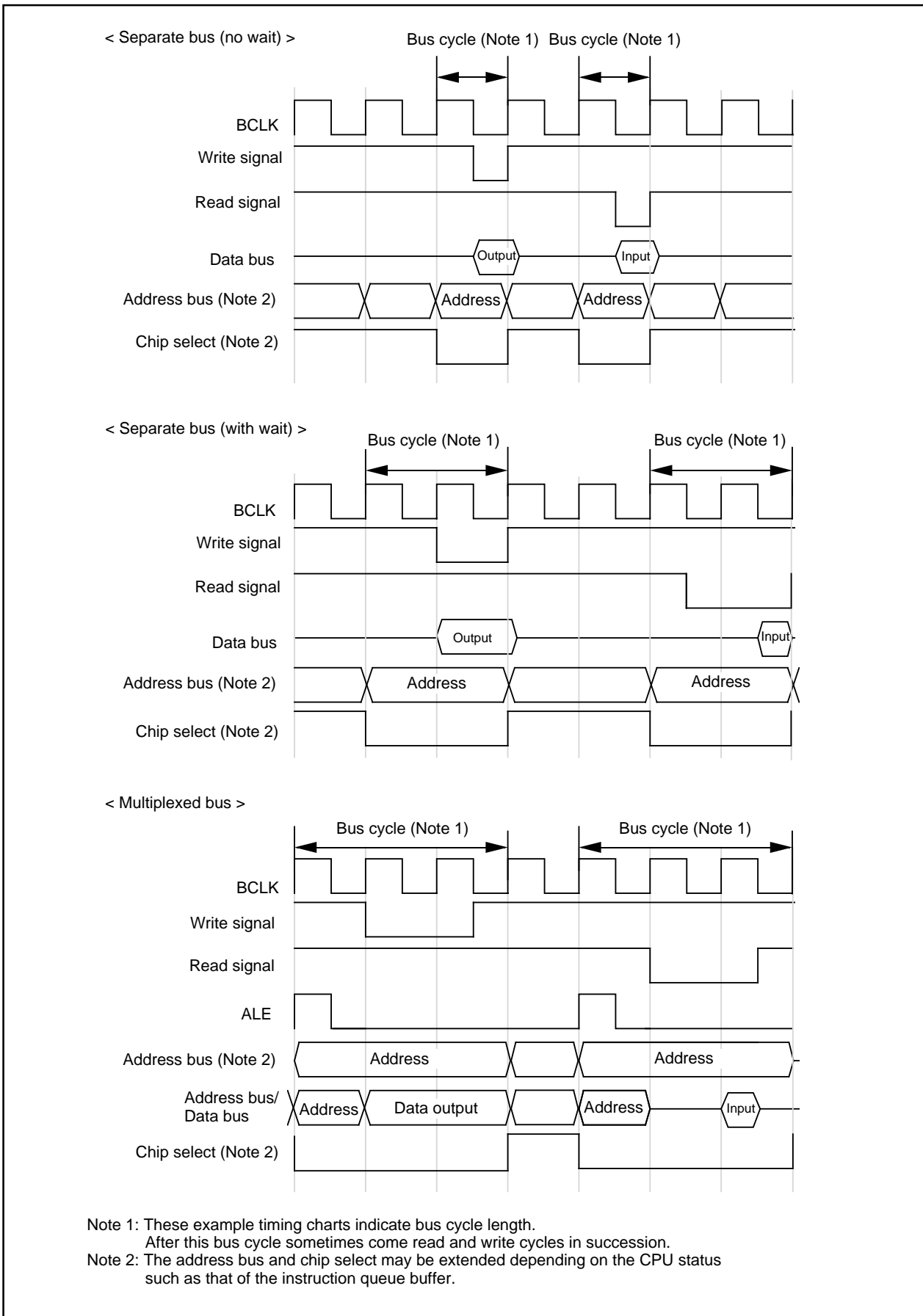

Figure 1.10.6. Typical bus timings using software wait

Clock Generating Circuit

The clock generating circuit contains two oscillator circuits that supply the operating clock sources to the CPU and internal peripheral units.

Table 1.11.1. Main clock and sub-clock generating circuits

	Main clock generating circuit	Sub-clock generating circuit
Use of clock	<ul style="list-style-type: none"> • CPU's operating clock source • Internal peripheral units' operating clock source 	<ul style="list-style-type: none"> • CPU's operating clock source • Timer A/B's count clock source
Usable oscillator	Ceramic or crystal oscillator	Crystal oscillator
Pins to connect oscillator	XIN, XOUT	XCIN, XCOUT
Oscillation stop/restart function	Available	Available
Oscillator status immediately after reset	Oscillating	Stopped
Other	Externally derived clock can be input	

Example of oscillator circuit

Figure 1.11.1 shows some examples of the main clock circuit, one using an oscillator connected to the circuit, and the other one using an externally derived clock for input. Figure 1.11.2 shows some examples of sub-clock circuits, one using an oscillator connected to the circuit, and the other one using an externally derived clock for input. Circuit constants in Figures 1.11.1 and 1.11.2 vary with each oscillator used. Use the values recommended by the manufacturer of your oscillator.

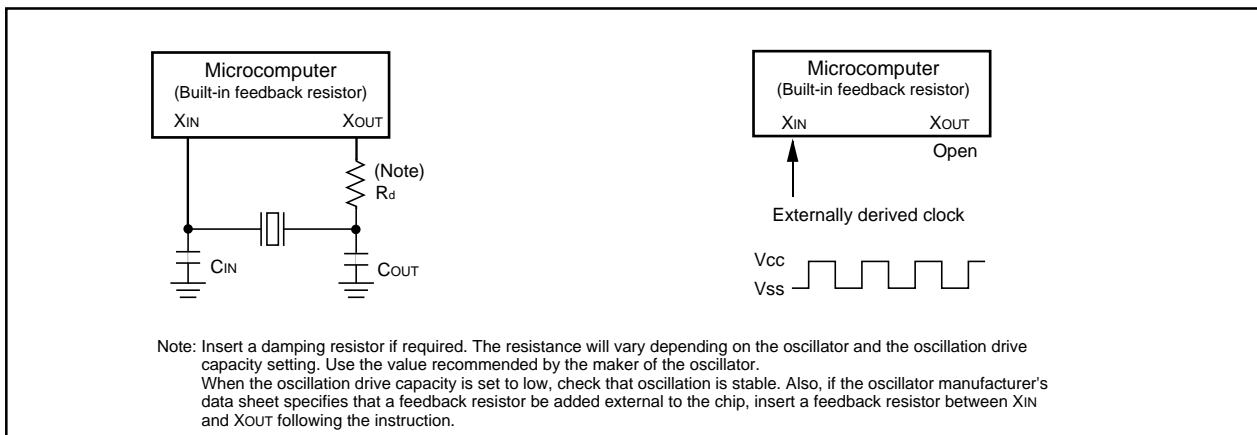

Figure 1.11.1. Examples of main clock

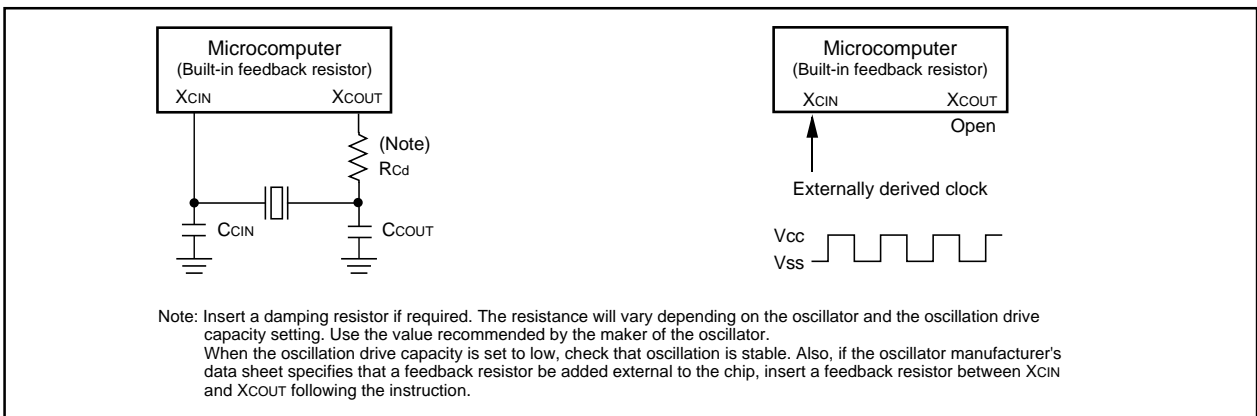

Figure 1.11.2. Examples of sub-clock

Clock Control

Figure 1.11.3 shows the block diagram of the clock generating circuit.

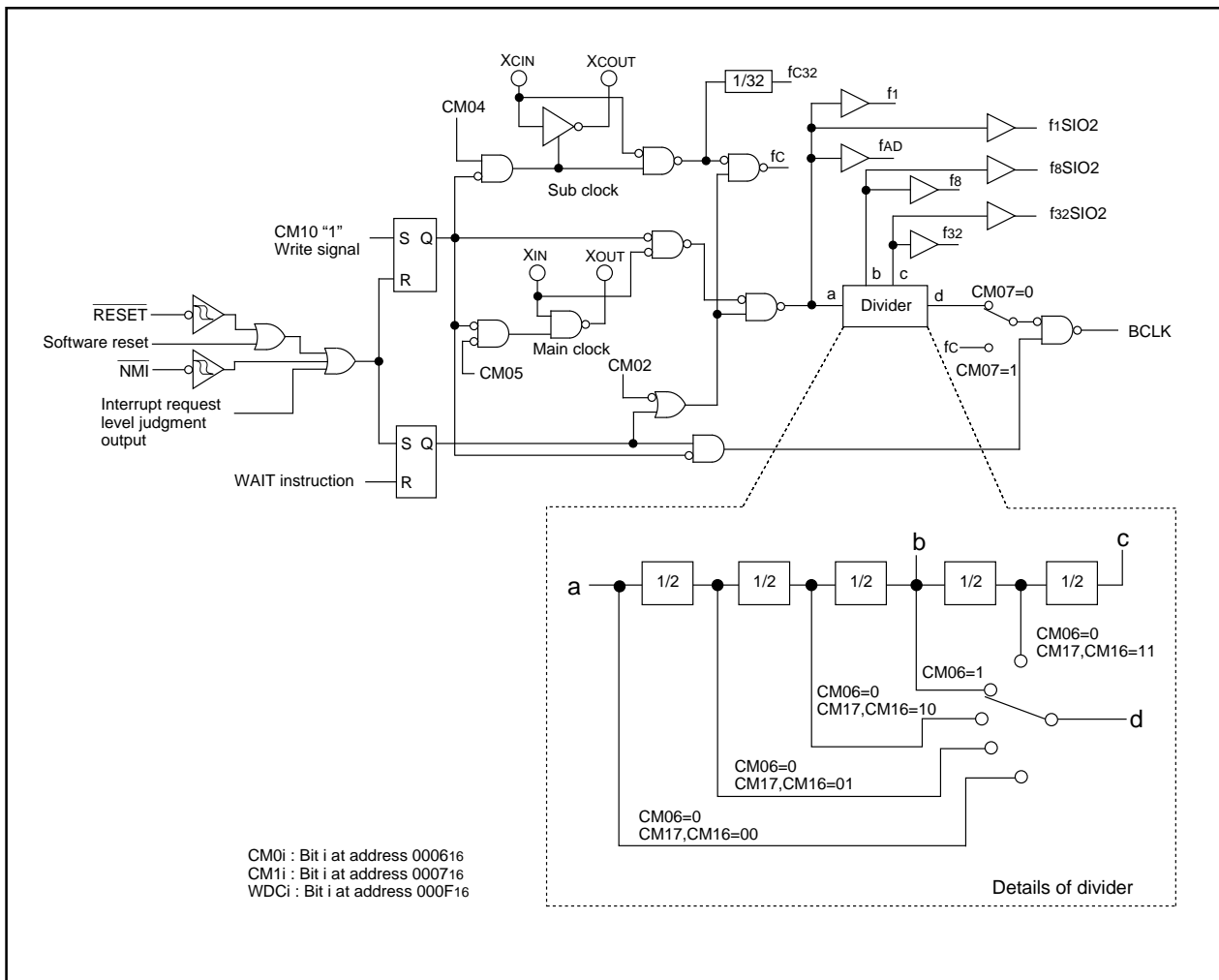

Figure 1.11.3. Clock generating circuit

The following paragraphs describes the clocks generated by the clock generating circuit.

(1) Main clock

The main clock is generated by the main clock oscillation circuit. After a reset, the clock is divided by 8 to the BCLK. The clock can be stopped using the main clock stop bit (bit 5 at address 0006₁₆). Stopping the clock, after switching the operating clock source of CPU to the sub-clock, reduces the power dissipation. After the oscillation of the main clock oscillation circuit has stabilized, the drive capacity of the main clock oscillation circuit can be reduced using the X_{IN}-X_{OUT} drive capacity select bit (bit 5 at address 0007₁₆). Reducing the drive capacity of the main clock oscillation circuit reduces the power dissipation. This bit changes to "1" when shifting from high-speed/medium-speed mode to stop mode, shifting to low power dissipation mode and at a reset. When shifting from high-speed/medium-speed mode to low-speed mode, the value before high-speed/medium-speed mode is retained.

(2) Sub-clock

The sub-clock is generated by the sub-clock oscillation circuit. No sub-clock is generated after a reset. After oscillation is started using the port Xc select bit (bit 4 at address 0006₁₆), the sub-clock can be selected as the BCLK by using the system clock select bit (bit 7 at address 0006₁₆). However, be sure that the sub-clock oscillation has fully stabilized before switching. After the oscillation of the sub-clock oscillation circuit has stabilized, the drive capacity of the sub-clock oscillation circuit can be reduced using the X_{CIN}-X_{COU}T drive capacity select bit (bit 3 at address 0006₁₆). Reducing the drive capacity of the sub-clock oscillation circuit reduces the power dissipation. This bit changes to "1" when the port Xc select bit (bit 4 at address 0006₁₆) is set to "0", shifting to stop mode and at a reset.

When the X_{CIN}/X_{COU}T is used, set ports P86 and P87 as the input ports without pull-up.

(3) BCLK

The BCLK is the clock that drives the CPU, and is fc or the clock is derived by dividing the main clock by 1, 2, 4, 8, or 16. The BCLK is derived by dividing the main clock by 8 after a reset. The BCLK signal can be output from BCLK pin by the BCLK output disable bit (bit 7 at address 0004₁₆) in the memory expansion and the microprocessor modes.

The main clock division select bit 0 (bit 6 at address 0006₁₆) changes to "1" when shifting from high-speed/medium-speed to stop mode, shifting to low power dissipation mode and at reset. When shifting from high-speed/medium-speed mode to low-speed mode, the value before high-speed/medium-speed mode is retained.

(4) Peripheral function clock(f₁, f₈, f₃₂, f_{1SIO2}, f_{8SIO2},f_{32SIO2},f_{AD})

The clock for the peripheral devices is derived from the main clock or by dividing it by 1, 8, or 32. The peripheral function clock is stopped by stopping the main clock or by setting the WAIT peripheral function clock stop bit (bit 2 at 0006₁₆) to "1" and then executing a WAIT instruction.

(5) fc32

This clock is derived by dividing the sub-clock by 32. It is used for the timer A and timer B counts.

(6) fc

This clock has the same frequency as the sub-clock. It is used for the BCLK and for the watchdog timer.

Figure 1.11.4 shows the system clock control registers 0 and 1.

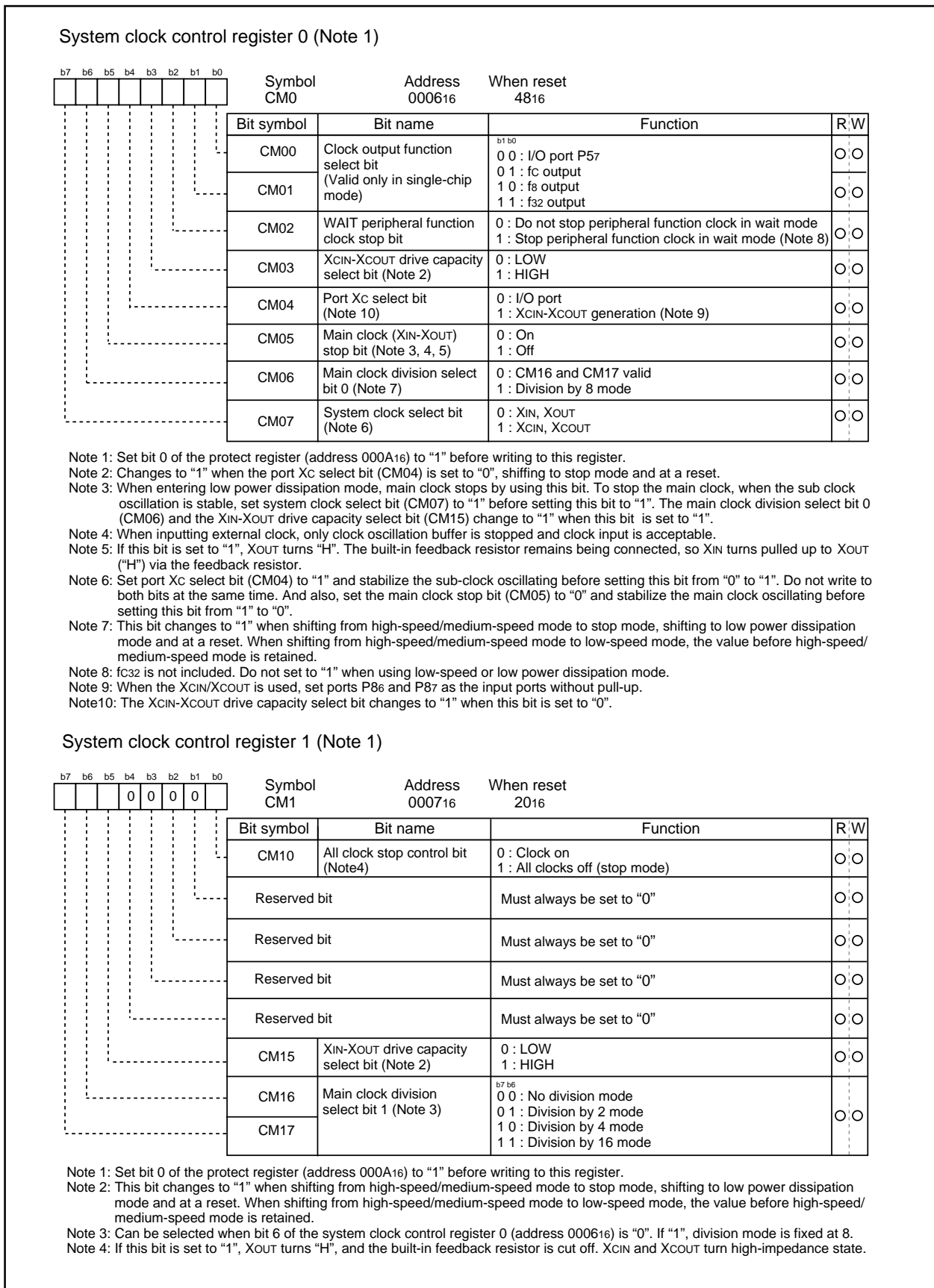

Figure 1.11.4. Clock control registers 0 and 1

Clock Output

In single-chip mode, the clock output function select bits (bits 0 and 1 at address 000616) enable f8, f32, or fc to be output from the P57/CLKOUT pin. When the WAIT peripheral function clock stop bit (bit 2 at address 000616) is set to "1", the output of f8 and f32 stops when a WAIT instruction is executed.

Stop Mode

Writing "1" to the all-clock stop control bit (bit 0 at address 000716) stops all oscillation and the microcomputer enters stop mode. In stop mode, the content of the internal RAM is retained provided that VCC remains above 2V.

Because the oscillation, BCLK, f1 to f32, f1SIO2 to f32SIO2, fc, fc32, and fAD stops in stop mode, peripheral functions such as the A-D converter and watchdog timer do not function. However, timer A and timer B operate provided that the event counter mode is set to an external pulse, and UARTi(i = 0 to 2), SI/O3,4 functions provided an external clock is selected. Table 1.11.2 shows the status of the ports in stop mode. Stop mode is cancelled by a hardware reset or an interrupt. If an interrupt is to be used to cancel stop mode, that interrupt must first have been enabled, and the priority level of the interrupt which is not used to cancel must have been changed to 0. If returning by an interrupt, that interrupt routine is executed. If only a hardware reset or an $\overline{\text{NMI}}$ interrupt is used to cancel stop mode, change the priority level of all interrupt to 0, then shift to stop mode.

The main clock division select bit 0 (bit 6 at address 000616) changes to "1" when shifting from high-speed/medium-speed mode to stop mode, shifting to low power dissipation mode and at reset. When shifting from high-speed/medium-speed mode to low-speed mode, the value before high-speed/medium-speed mode is retained.

Table 1.11.2. Port status during stop mode

Pin		Memory expansion mode Microprocessor mode	Single-chip mode
Address bus, data bus, $\overline{\text{CS0}}$ to $\overline{\text{CS3}}$, $\overline{\text{BHE}}$		Retains status before stop mode	/
RD, WR, WRL, WRH		"H"	
HLDA, BCLK		"H"	
ALE		"H"	
Port		Retains status before stop mode	
CLKOUT	When fc selected	Valid only in single-chip mode	"H"
	When f8, f32 selected	Valid only in single-chip mode	Retains status before stop mode

Wait Mode

When a WAIT instruction is executed, the BCLK stops and the microcomputer enters the wait mode. In this mode, oscillation continues but the BCLK and watchdog timer stop. Writing "1" to the WAIT peripheral function clock stop bit and executing a WAIT instruction stops the clock being supplied to the internal peripheral functions, allowing power dissipation to be reduced. However, peripheral function clock fc32 does not stop so that the peripherals using fc32 do not contribute to the power saving. When the MCU running in low-speed or low power dissipation mode, do not enter WAIT mode with this bit set to "1". Table 1.11.3 shows the status of the ports in wait mode.

Wait mode is cancelled by a hardware reset or an interrupt. If an interrupt is used to cancel wait mode, that interrupt must first have been enabled, and the priority level of the interrupt which is not used to cancel must have been changed to 0. If returning by an interrupt, the clock in which the WAIT instruction executed is set to BCLK by the microcomputer, and the action is resumed from the interrupt routine. If only a hardware reset or an $\overline{\text{NMI}}$ interrupt is used to cancel wait mode, change the priority level of all interrupt to 0, then shift to wait mode.

Table 1.11.3. Port status during wait mode

Pin		Memory expansion mode Microprocessor mode	Single-chip mode
Address bus, data bus, $\overline{\text{CS0}}$ to $\overline{\text{CS3}}$, $\overline{\text{BHE}}$		Retains status before wait mode	/
RD, WR, $\overline{\text{WRL}}$, $\overline{\text{WRH}}$		"H"	
HLDA, BCLK		"H"	
ALE		"H"	
Port		Retains status before wait mode	
CLKOUT	When fc selected	Valid only in single-chip mode	Does not stop
	When f8, f32 selected	Valid only in single-chip mode	Does not stop when the WAIT peripheral function clock stop bit is "0". When the WAIT peripheral function clock stop bit is "1", the status immediately prior to entering wait mode is maintained.

Status Transition of BCLK

Power dissipation can be reduced and low-voltage operation achieved by changing the count source for BCLK. Table 1.11.4 shows the operating modes corresponding to the settings of system clock control registers 0 and 1.

When reset, the device starts in division by 8 mode. The main clock division select bit 0 (bit 6 at address 0006₁₆) and the XIN-XOUT drive capacity select bit (bit 5 at address 0007₁₆) change to “1” when shifting from high-speed/medium-speed mode to stop mode, shifting to low power dissipation mode and at a reset. When shifting from high-speed/medium-speed mode to low-speed mode, the value before high-speed/medium-speed mode is retained. The following shows the operational modes of BCLK.

(1) Division by 2 mode

The main clock is divided by 2 to obtain the BCLK.

(2) Division by 4 mode

The main clock is divided by 4 to obtain the BCLK.

(3) Division by 8 mode

The main clock is divided by 8 to obtain the BCLK. When reset, the device starts operating from this mode. Before the user can go from this mode to no division mode, division by 2 mode, or division by 4 mode, the main clock must be oscillating stably. When going to low-speed or lower power consumption mode, make sure the sub-clock is oscillating stably.

(4) Division by 16 mode

The main clock is divided by 16 to obtain the BCLK.

(5) No-division mode

The main clock is divided by 1 to obtain the BCLK.

(6) Low-speed mode

fc is used as the BCLK. Note that oscillation of both the main and sub-clocks must have stabilized before transferring from this mode to another or vice versa. At least 2 to 3 seconds are required after the sub-clock starts. Therefore, the program must be written to wait until this clock has stabilized immediately after powering up and after stop mode is cancelled.

(7) Low power dissipation mode

fc is the BCLK and the main clock is stopped.

Note : Before the count source for BCLK can be changed from XIN to XCIN or vice versa, the clock to which the count source is going to be switched must be oscillating stably. Allow a wait time in software for the oscillation to stabilize before switching over the clock.

Table 1.11.4. Operating modes dictated by settings of system clock control registers 0 and 1

CM17	CM16	CM07	CM06	CM05	CM04	Operating mode of BCLK
0	1	0	0	0	Invalid	Division by 2 mode
1	0	0	0	0	Invalid	Division by 4 mode
Invalid	Invalid	0	1	0	Invalid	Division by 8 mode
1	1	0	0	0	Invalid	Division by 16 mode
0	0	0	0	0	Invalid	No-division mode
Invalid	Invalid	1	Invalid	0	1	Low-speed mode
Invalid	Invalid	1	Invalid	1	1	Low power dissipation mode

CM1i : bit i of the address 0007₁₆

CM0i : bit i of the address 0006₁₆

Power control

The following is a description of the three available power control modes:

Modes

Power control is available in three modes.

(a) Normal operation mode

- **High-speed mode**

Divide-by-1 frequency of the main clock becomes the BCLK. The CPU operates with the BCLK. Each peripheral function operates according to its assigned clock.

- **Medium-speed mode**

Divide-by-2, divide-by-4, divide-by-8, or divide-by-16 frequency of the main clock becomes the BCLK. The CPU operates with the BCLK. Each peripheral function operates according to its assigned clock.

- **Low-speed mode**

fc becomes the BCLK. The CPU operates according to the fc clock. The fc clock is supplied by the subclock. Each peripheral function operates according to its assigned clock.

- **Low power dissipation mode**

The main clock operating in low-speed mode is stopped. The CPU operates according to the fc clock. The fc clock is supplied by the subclock. The only peripheral functions that operate are those with the subclock selected as the count source.

(b) Wait mode

The CPU operation is stopped. The oscillators do not stop.

(c) Stop mode

All oscillators stop. The CPU and all built-in peripheral functions stop. This mode, among the three modes listed here, is the most effective in decreasing power consumption.

Figure 1.11.5 is the state transition diagram of the above modes.

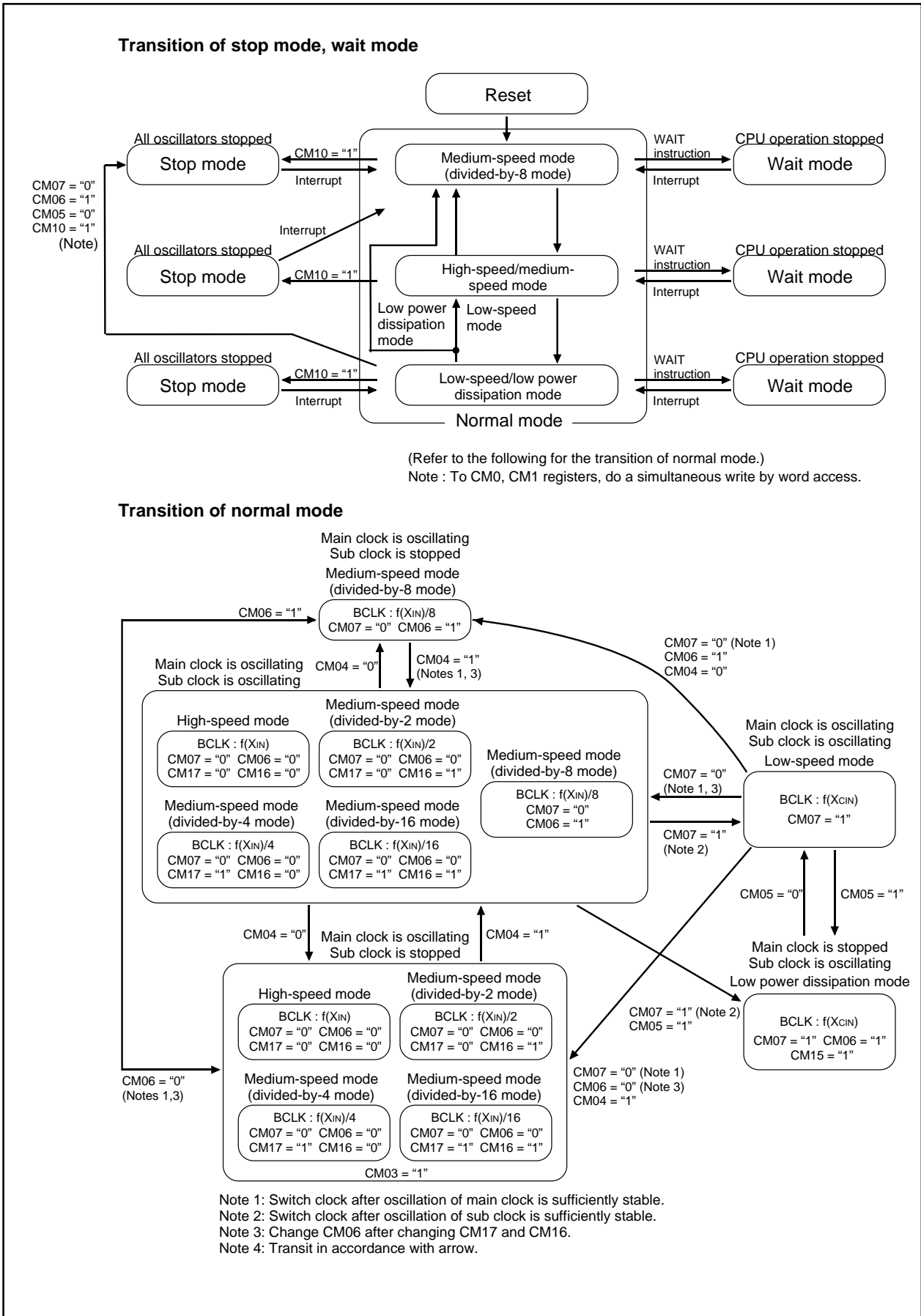

Figure 1.11.5. State transition diagram of Power control mode

Protection

The protection function is provided so that the values in important registers cannot be changed in the event that the program runs out of control. Figure 1.11.6 shows the protect register. The values in the processor mode register 0 (address 0004₁₆), processor mode register 1 (address 0005₁₆), system clock control register 0 (address 0006₁₆), system clock control register 1 (address 0007₁₆), port P9 direction register (address 03F3₁₆), SI/O3 control register (address 0362₁₆) and SI/O4 control register (address 0366₁₆) can only be changed when the respective bit in the protect register is set to "1". Therefore, important outputs can be allocated to port P9.

If, after "1" (write-enabled) has been written to the port P9 direction register and SI/O_i control register (i=3,4) write-enable bit (bit 2 at address 000A₁₆), a value is written to any address, the bit automatically reverts to "0" (write-inhibited). However, the system clock control registers 0 and 1 write-enable bit (bit 0 at 000A₁₆) and processor mode register 0 and 1 write-enable bit (bit 1 at 000A₁₆) do not automatically return to "0" after a value has been written to an address. The program must therefore be written to return these bits to "0".

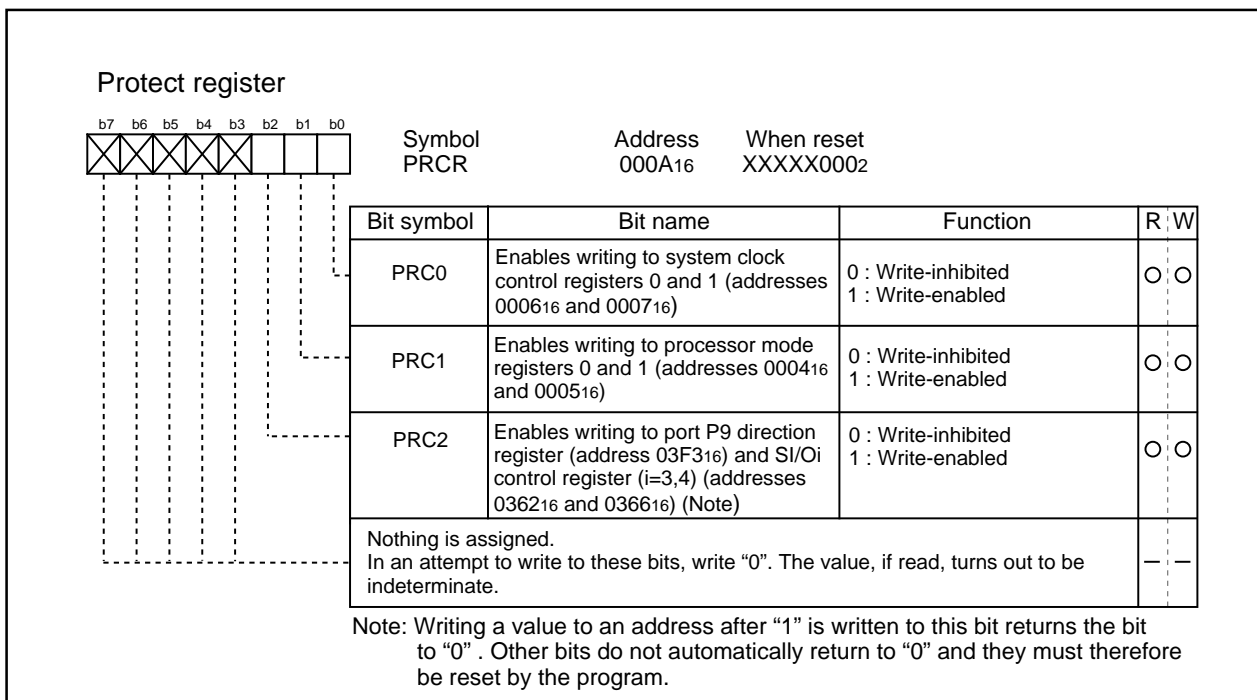

Figure 1.11.6. Protect register

Overview of Interrupt

Type of Interrupts

Figure 1.12.1 lists the types of interrupts.

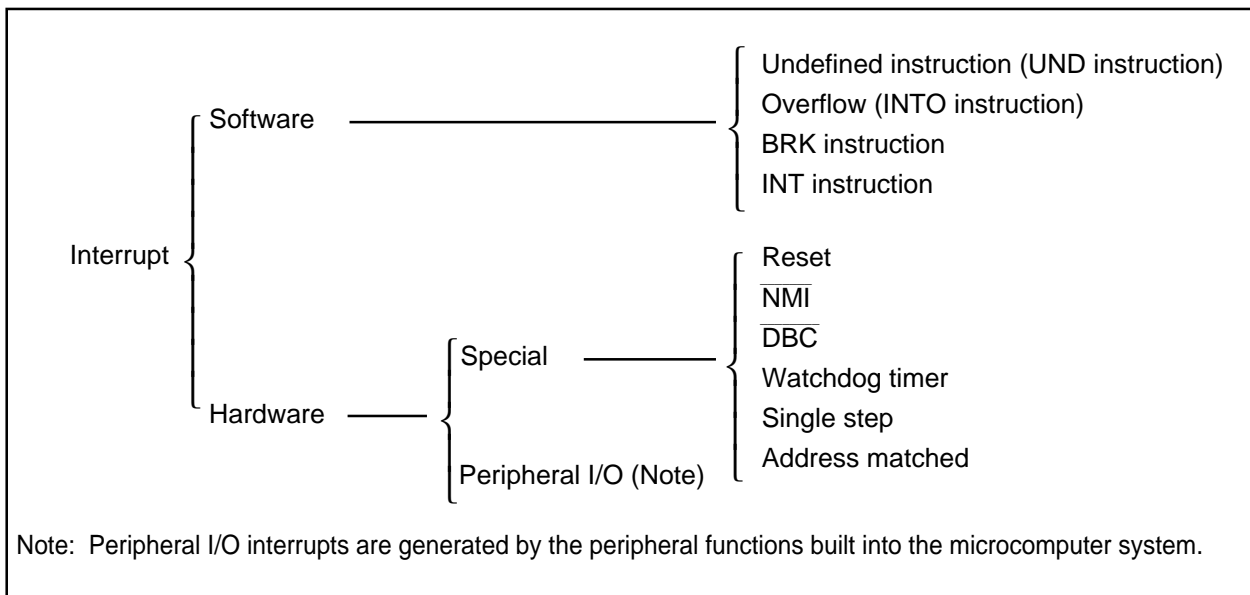

Figure 1.12.1. Classification of interrupts

- Maskable interrupt : An interrupt which can be enabled (disabled) by the interrupt enable flag (I flag) or whose interrupt priority **can be changed** by priority level.
- Non-maskable interrupt : An interrupt which cannot be enabled (disabled) by the interrupt enable flag (I flag) or whose interrupt priority **cannot be changed** by priority level.

Software Interrupts

A software interrupt occurs when executing certain instructions. Software interrupts are non-maskable interrupts.

- **Undefined instruction interrupt**

An undefined instruction interrupt occurs when executing the UND instruction.

- **Overflow interrupt**

An overflow interrupt occurs when executing the INTO instruction with the overflow flag (O flag) set to "1". The following are instructions whose O flag changes by arithmetic:

ABS, ADC, ADCF, ADD, CMP, DIV, DIVU, DIVX, NEG, RMPA, SBB, SHA, SUB

- **BRK interrupt**

A BRK interrupt occurs when executing the BRK instruction.

- **INT interrupt**

An INT interrupt occurs when specifying one of software interrupt numbers 0 through 63 and executing the INT instruction. Software interrupt numbers 0 through 31 are assigned to peripheral I/O interrupts, so executing the INT instruction allows executing the same interrupt routine that a peripheral I/O interrupt does.

The stack pointer (SP) used for the INT interrupt is dependent on which software interrupt number is involved.

So far as software interrupt numbers 0 through 31 are concerned, the microcomputer saves the stack pointer assignment flag (U flag) when it accepts an interrupt request. If change the U flag to "0" and select the interrupt stack pointer (ISP), and then execute an interrupt sequence. When returning from the interrupt routine, the U flag is returned to the state it was before the acceptance of interrupt request. So far as software numbers 32 through 63 are concerned, the stack pointer does not make a shift.

Hardware Interrupts

Hardware interrupts are classified into two types — special interrupts and peripheral I/O interrupts.

(1) Special interrupts

Special interrupts are non-maskable interrupts.

- **Reset**

Reset occurs if an “L” is input to the $\overline{\text{RESET}}$ pin.

- **$\overline{\text{NMI}}$ interrupt**

An $\overline{\text{NMI}}$ interrupt occurs if an “L” is input to the $\overline{\text{NMI}}$ pin.

- **$\overline{\text{DBC}}$ interrupt**

This interrupt is exclusively for the debugger, do not use it in other circumstances.

- **Watchdog timer interrupt**

Generated by the watchdog timer. Write to the watchdog timer start register after the watchdog timer interrupt occurs (initialize watchdog timer).

- **Single-step interrupt**

This interrupt is exclusively for the debugger, do not use it in other circumstances. With the debug flag (D flag) set to “1”, a single-step interrupt occurs after one instruction is executed.

- **Address match interrupt**

An address match interrupt occurs immediately before the instruction held in the address indicated by the address match interrupt register is executed with the address match interrupt enable bit set to “1”. If an address other than the first address of the instruction in the address match interrupt register is set, no address match interrupt occurs.

(2) Peripheral I/O interrupts

A peripheral I/O interrupt is generated by one of built-in peripheral functions. Built-in peripheral functions are dependent on classes of products, so the interrupt factors too are dependent on classes of products. The interrupt vector table is the same as the one for software interrupt numbers 0 through 31 the INT instruction uses. Peripheral I/O interrupts are maskable interrupts.

- **Bus collision detection interrupt**

This is an interrupt that the serial I/O bus collision detection generates.

- **DMA0 interrupt, DMA1 interrupt**

These are interrupts that DMA generates.

- **Key-input interrupt**

A key-input interrupt occurs if an “L” is input to the $\overline{\text{KI}}$ pin.

- **A-D conversion interrupt**

This is an interrupt that the A-D converter generates.

- **UART0, UART1, UART2/NACK, SI/O3 and SI/O4 transmission interrupt**

These are interrupts that the serial I/O transmission generates.

- **UART0, UART1, UART2/ACK, SI/O3 and SI/O4 reception interrupt**

These are interrupts that the serial I/O reception generates.

- **Timer A0 interrupt through timer A4 interrupt**

These are interrupts that timer A generates

- **Timer B0 interrupt through timer B5 interrupt**

These are interrupts that timer B generates.

- **$\overline{\text{INT0}}$ interrupt through $\overline{\text{INT5}}$ interrupt**

An $\overline{\text{INT}}$ interrupt occurs if either a rising edge or a falling edge or a both edge is input to the $\overline{\text{INT}}$ pin.

Interrupts and Interrupt Vector Tables

If an interrupt request is accepted, a program branches to the interrupt routine set in the interrupt vector table. Set the first address of the interrupt routine in each vector table. Figure 1.12.2 shows the format for specifying the address.

Two types of interrupt vector tables are available — fixed vector table in which addresses are fixed and variable vector table in which addresses can be varied by the setting.

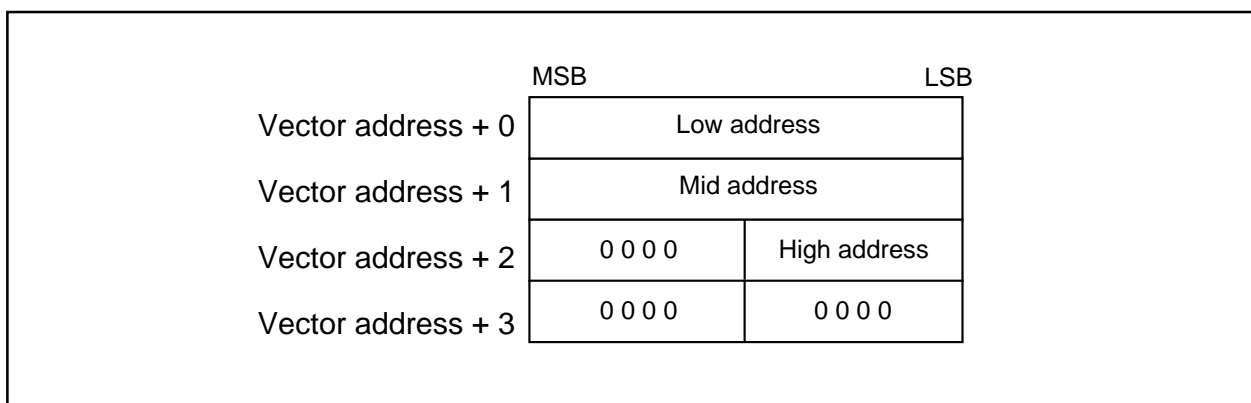

Figure 1.12.2. Format for specifying interrupt vector addresses

• **Fixed vector tables**

The fixed vector table is a table in which addresses are fixed. The vector tables are located in an area extending from FFFDC₁₆ to FFFFF₁₆. One vector table comprises four bytes. Set the first address of interrupt routine in each vector table. Table 1.12.1 shows the interrupts assigned to the fixed vector tables and addresses of vector tables.

Table 1.12.1. Interrupts assigned to the fixed vector tables and addresses of vector tables

Interrupt source	Vector table addresses Address (L) to address (H)	Remarks
Undefined instruction	FFFD _{C16} to FFFD _{F16}	Interrupt on UND instruction
Overflow	FFFE ₀₁₆ to FFFE ₃₁₆	Interrupt on INTO instruction
BRK instruction	FFFE ₄₁₆ to FFFE ₇₁₆	If the vector contains FF ₁₆ , program execution starts from the address shown by the vector in the variable vector table
Address match	FFFE ₈₁₆ to FFFE _{B16}	There is an address-matching interrupt enable bit
Single step (Note)	FFFE _{C16} to FFFE _{F16}	Do not use
Watchdog timer	FFFF ₀₁₆ to FFFF ₃₁₆	
DBC (Note)	FFFF ₄₁₆ to FFFF ₇₁₆	Do not use
NMI	FFFF ₈₁₆ to FFFF _{B16}	External interrupt by input to $\overline{\text{NMI}}$ pin
Reset	FFFF _{C16} to FFFF _{F16}	

Note: Interrupts used for debugging purposes only.

- **Variable vector tables**

The addresses in the variable vector table can be modified, according to the user's settings. Indicate the first address using the interrupt table register (INTB). The 256-byte area subsequent to the address the INTB indicates becomes the area for the variable vector tables. One vector table comprises four bytes. Set the first address of the interrupt routine in each vector table. Table 1.12.2 shows the interrupts assigned to the variable vector tables and addresses of vector tables.

Table 1.12.2. Interrupts assigned to the variable vector tables and addresses of vector tables

Software interrupt number	Vector table address Address (L) to address (H)	Interrupt source	Remarks
Software interrupt number 0	+0 to +3 (Note 1)	BRK instruction	Cannot be masked I flag
Software interrupt number 4	+16 to +19 (Note 1)	$\overline{\text{INT3}}$	
Software interrupt number 5	+20 to +23 (Note 1)	Timer B5	
Software interrupt number 6	+24 to +27 (Note 1)	Timer B4	
Software interrupt number 7	+28 to +31 (Note 1)	Timer B3	
Software interrupt number 8	+32 to +35 (Note 1)	SI/O4/ $\overline{\text{INT5}}$ (Note 2)	
Software interrupt number 9	+36 to +39 (Note 1)	SI/O3/ $\overline{\text{INT4}}$ (Note 2)	
Software interrupt number 10	+40 to +43 (Note 1)	Bus collision detection	
Software interrupt number 11	+44 to +47 (Note 1)	DMA0	
Software interrupt number 12	+48 to +51 (Note 1)	DMA1	
Software interrupt number 13	+52 to +55 (Note 1)	Key input interrupt	
Software interrupt number 14	+56 to +59 (Note 1)	A-D	
Software interrupt number 15	+60 to +63 (Note 1)	UART2 transmit/NACK (Note 3)	
Software interrupt number 16	+64 to +67 (Note 1)	UART2 receive/ACK (Note 3)	
Software interrupt number 17	+68 to +71 (Note 1)	UART0 transmit	
Software interrupt number 18	+72 to +75 (Note 1)	UART0 receive	
Software interrupt number 19	+76 to +79 (Note 1)	UART1 transmit	
Software interrupt number 20	+80 to +83 (Note 1)	UART1 receive	
Software interrupt number 21	+84 to +87 (Note 1)	Timer A0	
Software interrupt number 22	+88 to +91 (Note 1)	Timer A1	
Software interrupt number 23	+92 to +95 (Note 1)	Timer A2	
Software interrupt number 24	+96 to +99 (Note 1)	Timer A3	
Software interrupt number 25	+100 to +103 (Note 1)	Timer A4	
Software interrupt number 26	+104 to +107 (Note 1)	Timer B0	
Software interrupt number 27	+108 to +111 (Note 1)	Timer B1	
Software interrupt number 28	+112 to +115 (Note 1)	Timer B2	
Software interrupt number 29	+116 to +119 (Note 1)	$\overline{\text{INT0}}$	
Software interrupt number 30	+120 to +123 (Note 1)	$\overline{\text{INT1}}$	
Software interrupt number 31	+124 to +127 (Note 1)	$\overline{\text{INT2}}$	
Software interrupt number 32 to Software interrupt number 63	+128 to +131 (Note 1) to +252 to +255 (Note 1)	Software interrupt	Cannot be masked I flag

Note 1: Address relative to address in interrupt table register (INTB).

Note 2: It is selected by interrupt request cause bit (bit 6, 7 in address 035F16).

Note 3: When IIC mode is selected, NACK and ACK interrupts are selected.

Interrupt Control

Descriptions are given here regarding how to enable or disable maskable interrupts and how to set the priority to be accepted. What is described here does not apply to non-maskable interrupts.

Enable or disable a maskable interrupt using the interrupt enable flag (I flag), interrupt priority level selection bit, or processor interrupt priority level (IPL). Whether an interrupt request is present or absent is indicated by the interrupt request bit. The interrupt request bit and the interrupt priority level selection bit are located in the interrupt control register of each interrupt. Also, the interrupt enable flag (I flag) and the IPL are located in the flag register (FLG).

Figure 1.12.3 shows the memory map of the interrupt control registers.

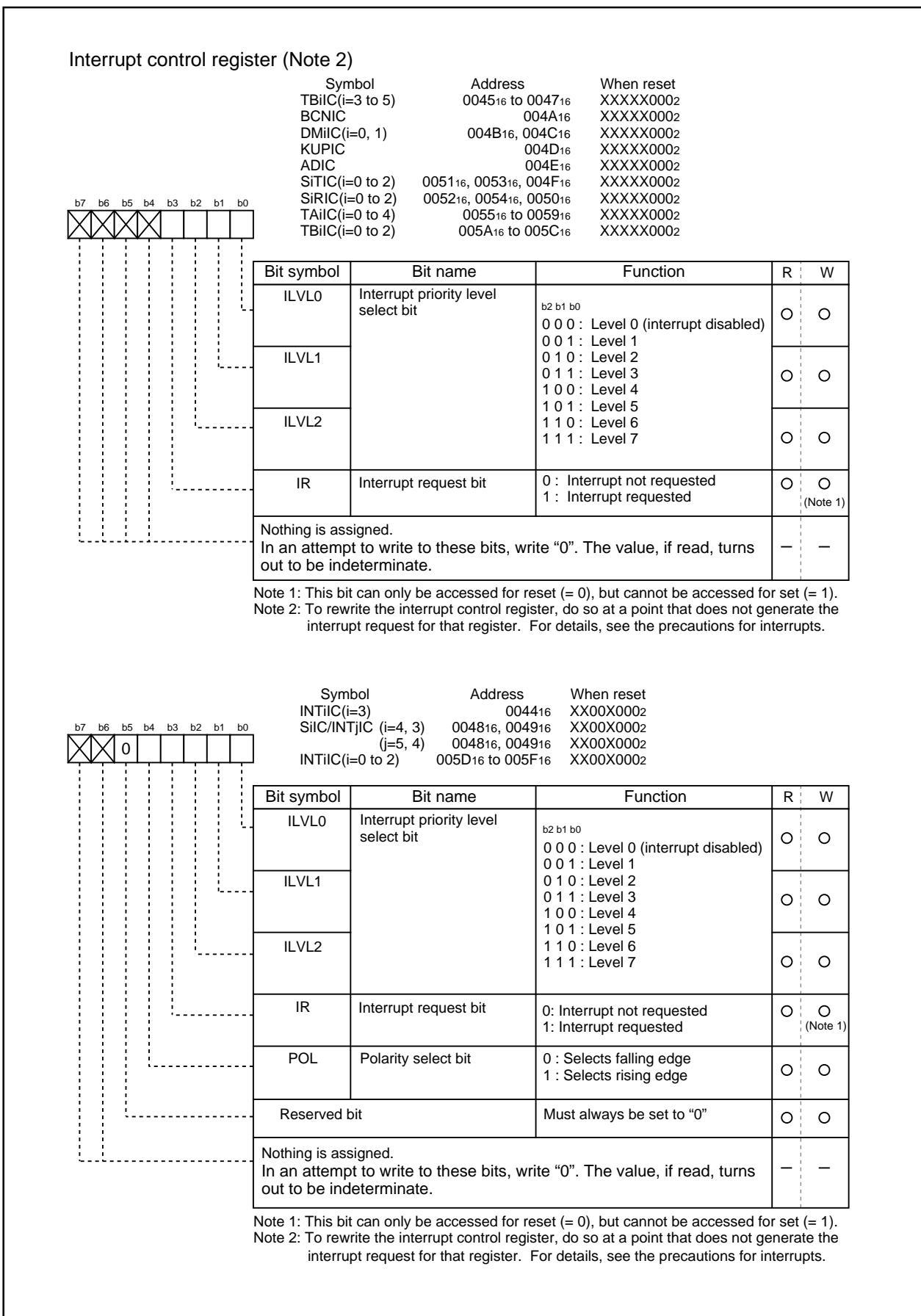

Figure 1.12.3. Interrupt control registers

Interrupt Enable Flag (I flag)

The interrupt enable flag (I flag) controls the enabling and disabling of maskable interrupts. Setting this flag to “1” enables all maskable interrupts; setting it to “0” disables all maskable interrupts. This flag is set to “0” after reset.

Interrupt Request Bit

The interrupt request bit is set to “1” by hardware when an interrupt is requested. After the interrupt is accepted and jumps to the corresponding interrupt vector, the request bit is set to “0” by hardware. The interrupt request bit can also be set to “0” by software. (Do not set this bit to “1”).

Interrupt Priority Level Select Bit and Processor Interrupt Priority Level (IPL)

Set the interrupt priority level using the interrupt priority level select bit, which is one of the component bits of the interrupt control register. When an interrupt request occurs, the interrupt priority level is compared with the IPL. The interrupt is enabled only when the priority level of the interrupt is higher than the IPL. Therefore, setting the interrupt priority level to “0” disables the interrupt.

Table 1.12.3 shows the settings of interrupt priority levels and Table 1.12.4 shows the interrupt levels enabled, according to the contents of the IPL.

The following are conditions under which an interrupt is accepted:

- interrupt enable flag (I flag) = “1”
- interrupt request bit = “1”
- interrupt priority level > IPL

The interrupt enable flag (I flag), the interrupt request bit, the interrupt priority select bit, and the IPL are independent, and they are not affected by one another.

Table 1.12.3. Settings of interrupt priority levels

Interrupt priority level select bit	Interrupt priority level	Priority order
b2 b1 b0 0 0 0	Level 0 (interrupt disabled)	————
0 0 1	Level 1	Low ↓ High
0 1 0	Level 2	
0 1 1	Level 3	
1 0 0	Level 4	
1 0 1	Level 5	
1 1 0	Level 6	
1 1 1	Level 7	

Table 1.12.4. Interrupt levels enabled according to the contents of the IPL

IPL	Enabled interrupt priority levels
IPL ₂ IPL ₁ IPL ₀ 0 0 0	Interrupt levels 1 and above are enabled
0 0 1	Interrupt levels 2 and above are enabled
0 1 0	Interrupt levels 3 and above are enabled
0 1 1	Interrupt levels 4 and above are enabled
1 0 0	Interrupt levels 5 and above are enabled
1 0 1	Interrupt levels 6 and above are enabled
1 1 0	Interrupt levels 7 and above are enabled
1 1 1	All maskable interrupts are disabled

Rewrite the interrupt control register

To rewrite the interrupt control register, do so at a point that does not generate the interrupt request for that register. If there is possibility of the interrupt request occur, rewrite the interrupt control register after the interrupt is disabled. The program examples are described as follow:

Example 1:

```
INT_SWITCH1:
  FCLR  I           ; Disable interrupts.
  AND.B #00h, 0055h ; Clear TA0IC int. priority level and int. request bit.
  NOP                    ; Four NOP instructions are required when using HOLD function.
  NOP
  FSET  I           ; Enable interrupts.
```

Example 2:

```
INT_SWITCH2:
  FCLR  I           ; Disable interrupts.
  AND.B #00h, 0055h ; Clear TA0IC int. priority level and int. request bit.
  MOV.W MEM, R0     ; Dummy read.
  FSET  I           ; Enable interrupts.
```

Example 3:

```
INT_SWITCH3:
  PUSHC FLG         ; Push Flag register onto stack
  FCLR  I           ; Disable interrupts.
  AND.B #00h, 0055h ; Clear TA0IC int. priority level and int. request bit.
  POPC  FLG         ; Enable interrupts.
```

The reason why two NOP instructions (four when using the HOLD function) or dummy read are inserted before FSET I in Examples 1 and 2 is to prevent the interrupt enable flag I from being set before the interrupt control register is rewritten due to effects of the instruction queue.

When changing an interrupt control register in a state of interrupts being disabled, please read the following precautions on instructions used before changing the register.

(1) Changing a non-interrupt request bit

If an interrupt request for an interrupt control register is generated during an instruction to rewrite the register is being executed, there is a case that the interrupt request bit is not set and consequently the interrupt is ignored. This will depend on the instruction. If this creates problems, use the below instructions to change the register.

Instructions : AND, OR, BCLR, BSET

(2) Changing the interrupt request bit

When attempting to clear the interrupt request bit of an interrupt control register, the interrupt request bit is not cleared sometimes. This will depend on the instruction. If this creates problems, use the below instructions to change the register.

Instructions : MOV

Interrupt Sequence

An interrupt sequence — what are performed over a period from the instant an interrupt is accepted to the instant the interrupt routine is executed — is described here.

If an interrupt occurs during execution of an instruction, the processor determines its priority when the execution of the instruction is completed, and transfers control to the interrupt sequence from the next cycle. If an interrupt occurs during execution of either the SMOVB, SMOVF, SSTR or RMPA instruction, the processor temporarily suspends the instruction being executed, and transfers control to the interrupt sequence.

In the interrupt sequence, the processor carries out the following in sequence given:

- (1) CPU gets the interrupt information (the interrupt number and interrupt request level) by reading address 00000₁₆. After this, the corresponding interrupt request bit becomes "0".
- (2) Saves the content of the flag register (FLG) as it was immediately before the start of interrupt sequence in the temporary register (Note) within the CPU.
- (3) Sets the interrupt enable flag (I flag), the debug flag (D flag), and the stack pointer select flag (U flag) to "0" (the U flag, however does not change if the INT instruction, in software interrupt numbers 32 through 63, is executed)
- (4) Saves the content of the temporary register (Note) within the CPU in the stack area.
- (5) Saves the content of the program counter (PC) in the stack area.
- (6) Sets the interrupt priority level of the accepted instruction in the IPL.

After the interrupt sequence is completed, the processor resumes executing instructions from the first address of the interrupt routine.

Note: This register cannot be utilized by the user.

Interrupt Response Time

'Interrupt response time' is the period between the instant an interrupt occurs and the instant the first instruction within the interrupt routine has been executed. This time comprises the period from the occurrence of an interrupt to the completion of the instruction under execution at that moment (a) and the time required for executing the interrupt sequence (b). Figure 1.12.4 shows the interrupt response time.

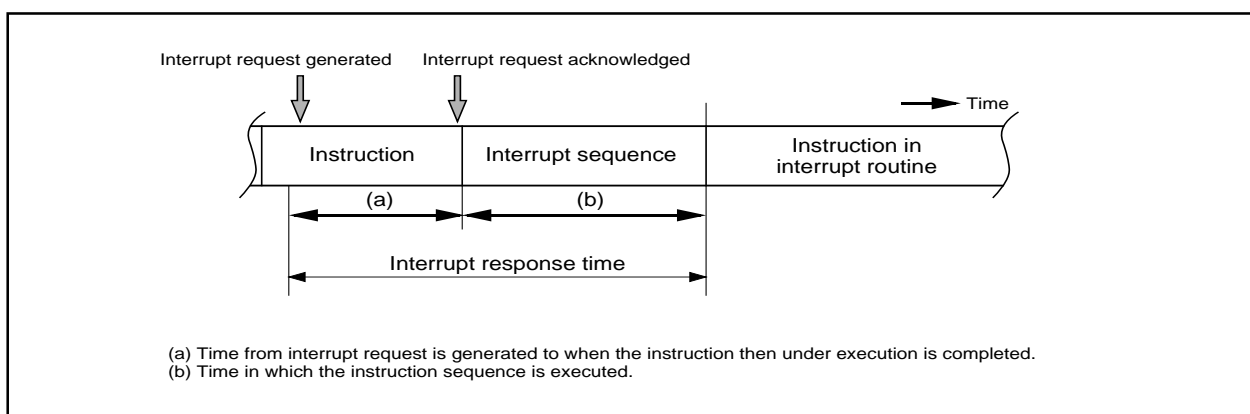

Figure 1.12.4. Interrupt response time

Time (a) is dependent on the instruction under execution. Thirty cycles is the maximum required for the DIVX instruction (without wait).

Time (b) is as shown in Table 1.12.5.

Table 1.12.5. Time required for executing the interrupt sequence

Interrupt vector address	Stack pointer (SP) value	16-Bit bus, without wait	8-Bit bus, without wait
Even	Even	18 cycles (Note 1)	20 cycles (Note 1)
Even	Odd	19 cycles (Note 1)	20 cycles (Note 1)
Odd (Note 2)	Even	19 cycles (Note 1)	20 cycles (Note 1)
Odd (Note 2)	Odd	20 cycles (Note 1)	20 cycles (Note 1)

Note 1: Add 2 cycles in the case of a DBC interrupt; add 1 cycle in the case either of an address match interrupt or of a single-step interrupt.

Note 2: Locate an interrupt vector address in an even address, if possible.

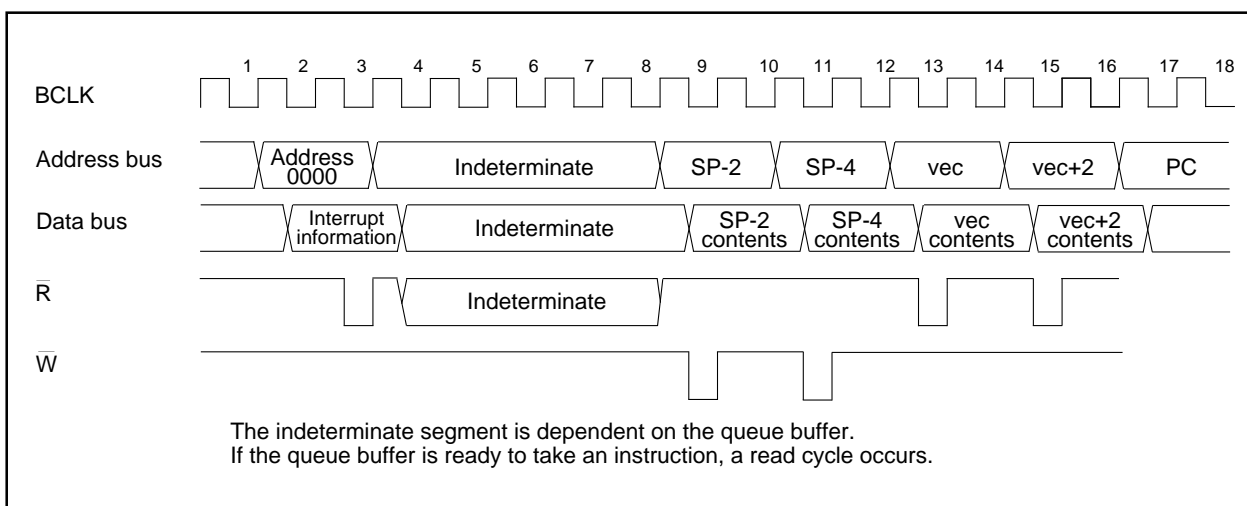

Figure 1.12.5. Time required for executing the interrupt sequence

Variation of IPL when Interrupt Request is Accepted

If an interrupt request is accepted, the interrupt priority level of the accepted interrupt is set in the IPL.

If an interrupt request, that does not have an interrupt priority level, is accepted, one of the values shown in Table 1.12.6 is set in the IPL.

Table 1.12.6. Relationship between interrupts without interrupt priority levels and IPL

Interrupt sources without priority levels	Value set in the IPL
Watchdog timer, NMI	7
Reset	0
Other	Not changed

Saving Registers

In the interrupt sequence, only the contents of the flag register (FLG) and that of the program counter (PC) are saved in the stack area.

First, the processor saves the four higher-order bits of the program counter, and 4 upper-order bits and 8 lower-order bits of the FLG register, 16 bits in total, in the stack area, then saves 16 lower-order bits of the program counter. Figure 1.12.6 shows the state of the stack as it was before the acceptance of the interrupt request, and the state the stack after the acceptance of the interrupt request.

Save other necessary registers at the beginning of the interrupt routine using software. Using the PUSHM instruction alone can save all the registers except the stack pointer (SP).

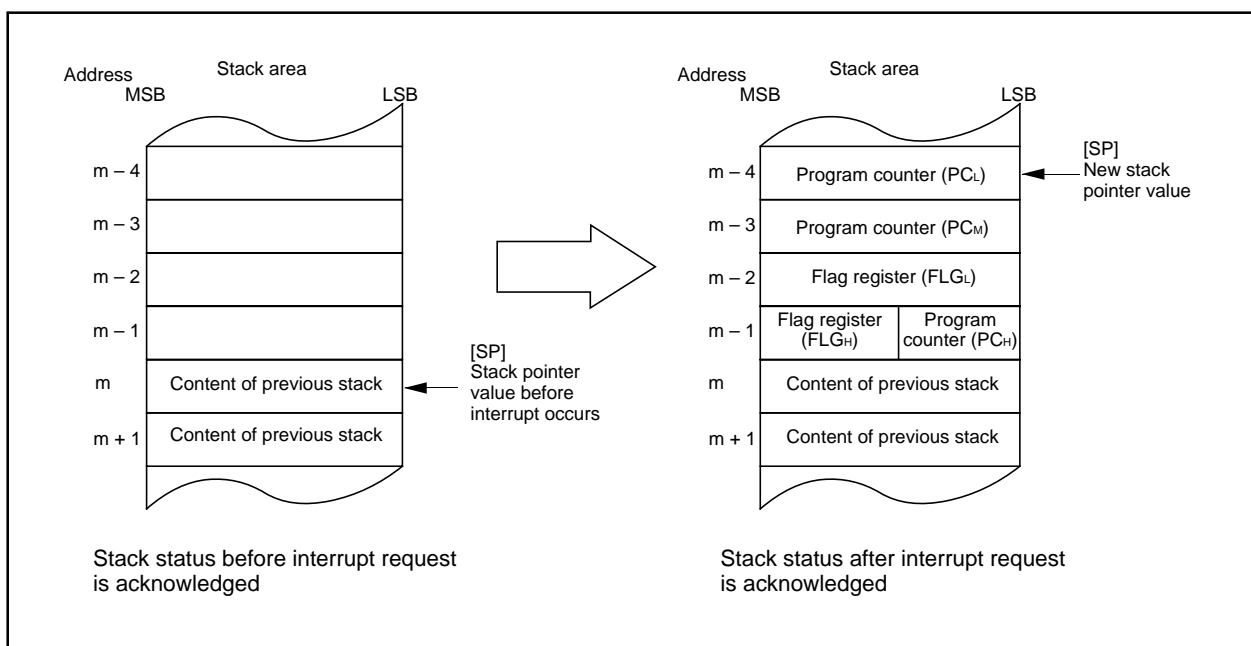

Figure 1.12.6. State of stack before and after acceptance of interrupt request

The operation of saving registers carried out in the interrupt sequence is dependent on whether the content of the stack pointer (Note) , at the time of acceptance of an interrupt request, is even or odd. If the content of the stack pointer (Note) is even, the content of the flag register (FLG) and the content of the program counter (PC) are saved, 16 bits at a time. If odd, their contents are saved in two steps, 8 bits at a time. Figure 1.12.7 shows the operation of the saving registers.

Note: When any INT instruction in software numbers 32 to 63 has been executed, this is the stack pointer indicated by the U flag. Otherwise, it is the interrupt stack pointer (ISP).

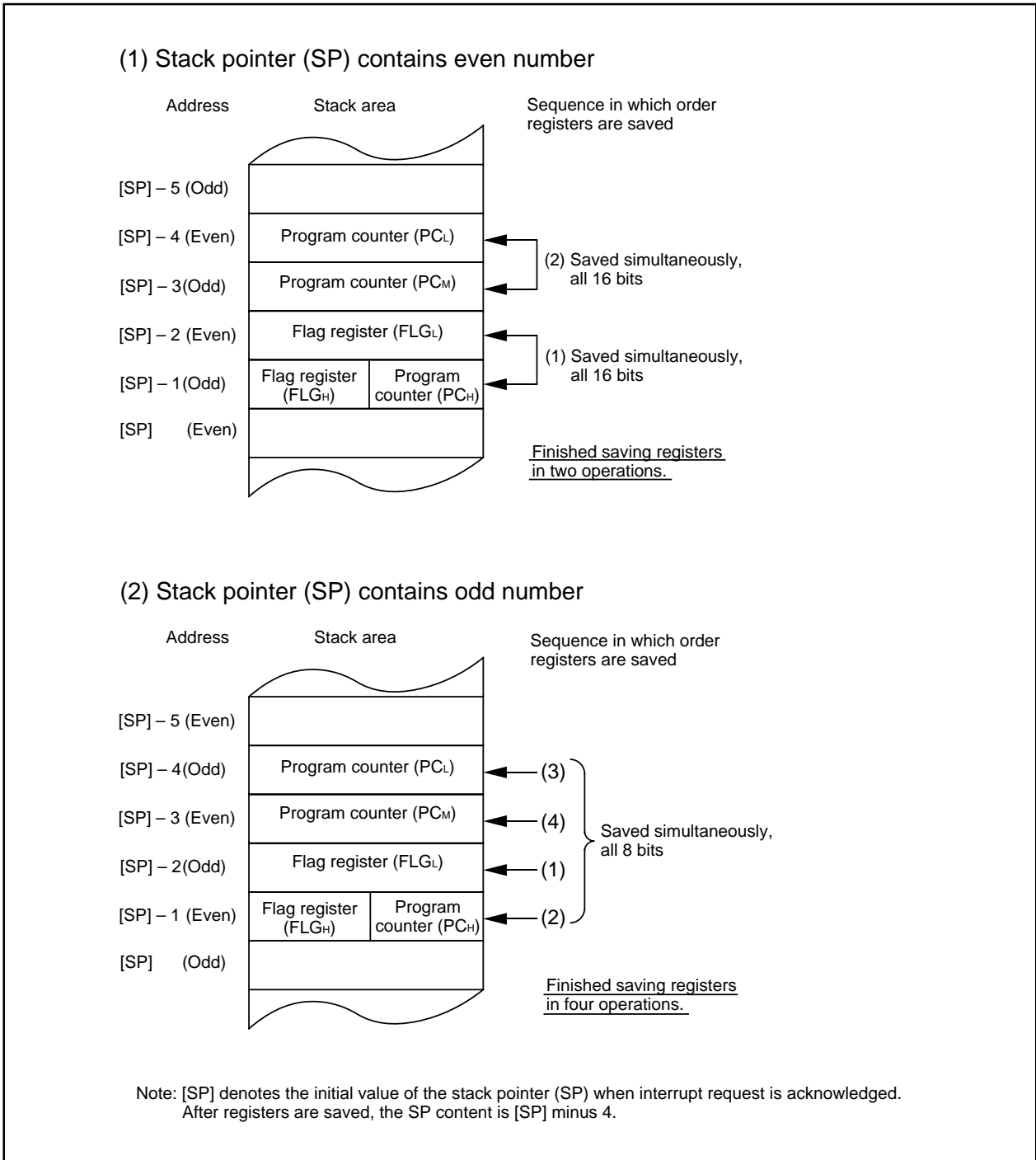

Figure 1.12.7. Operation of saving registers

Returning from an Interrupt Routine

Executing the REIT instruction at the end of an interrupt routine returns the contents of the flag register (FLG) as it was immediately before the start of interrupt sequence and the contents of the program counter (PC), both of which have been saved in the stack area. Then control returns to the program that was being executed before the acceptance of the interrupt request, so that the suspended process resumes. Return the other registers saved by software within the interrupt routine using the POPM or similar instruction before executing the REIT instruction.

Interrupt Priority

If there are two or more interrupt requests occurring at a point in time within a single sampling (checking whether interrupt requests are made), the interrupt assigned a higher priority is accepted.

Assign an arbitrary priority to maskable interrupts (peripheral I/O interrupts) using the interrupt priority level select bit. If the same interrupt priority level is assigned, however, the interrupt assigned a higher hardware priority is accepted.

Priorities of the special interrupts, such as Reset (dealt with as an interrupt assigned the highest priority), watchdog timer interrupt, etc. are regulated by hardware.

Figure 1.12.8 shows the priorities of hardware interrupts.

Software interrupts are not affected by the interrupt priority. If an instruction is executed, control branches invariably to the interrupt routine.

Reset > $\overline{\text{NMI}}$ > $\overline{\text{DBC}}$ > Watchdog timer > Peripheral I/O > Single step > Address match

Figure 1.12.8. Hardware interrupts priorities

Interrupt resolution circuit

When two or more interrupts are generated simultaneously, this circuit selects the interrupt with the highest priority level. Figure 1.12.9 shows the circuit that judges the interrupt priority level.

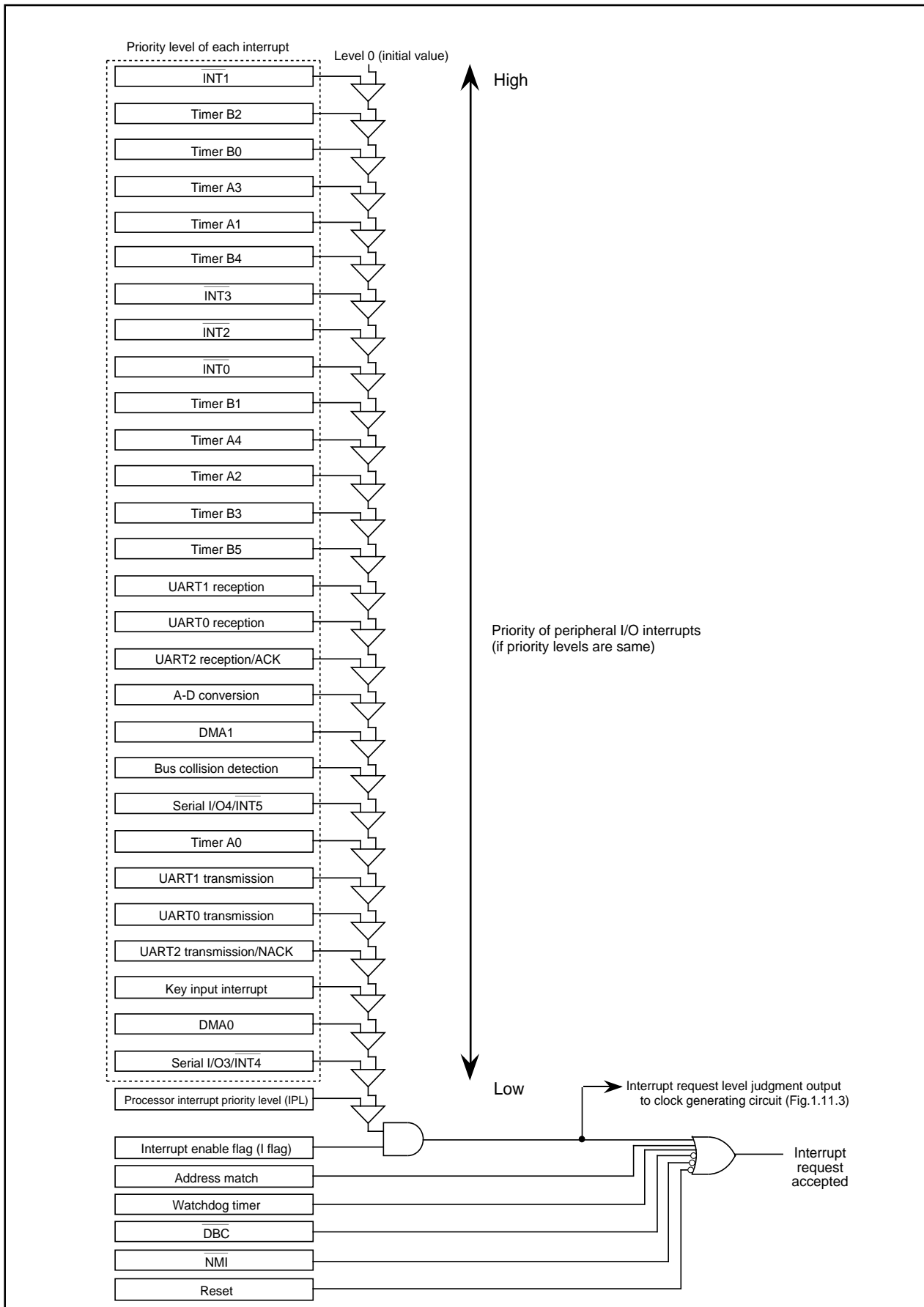

Figure 1.12.9. Maskable interrupts priorities (peripheral I/O interrupts)

INT Interrupt

INT0 to INT5 are triggered by the edges of external inputs. The edge polarity is selected using the polarity select bit.

Of interrupt control registers, 004816 is used both as serial I/O4 and external interrupt INT5 input control register, and 004916 is used both as serial I/O3 and as external interrupt INT4 input control register. Use the interrupt request cause select bits - bits 6 and 7 of the interrupt request cause select register (035F16) - to specify which interrupt request cause to select. After having set an interrupt request cause, be sure to clear the corresponding interrupt request bit before enabling an interrupt.

Either of the interrupt control registers - 004816, 004916 - has the polarity-switching bit. Be sure to set this bit to "0" to select an serial I/O as the interrupt request cause.

As for external interrupt input, an interrupt can be generated both at the rising edge and at the falling edge by setting "1" in the INTi interrupt polarity switching bit of the interrupt request cause select register (035F16). To select both edges, set the polarity switching bit of the corresponding interrupt control register to 'falling edge' ("0").

Figure 1.12.10 shows the Interrupt request cause select register.

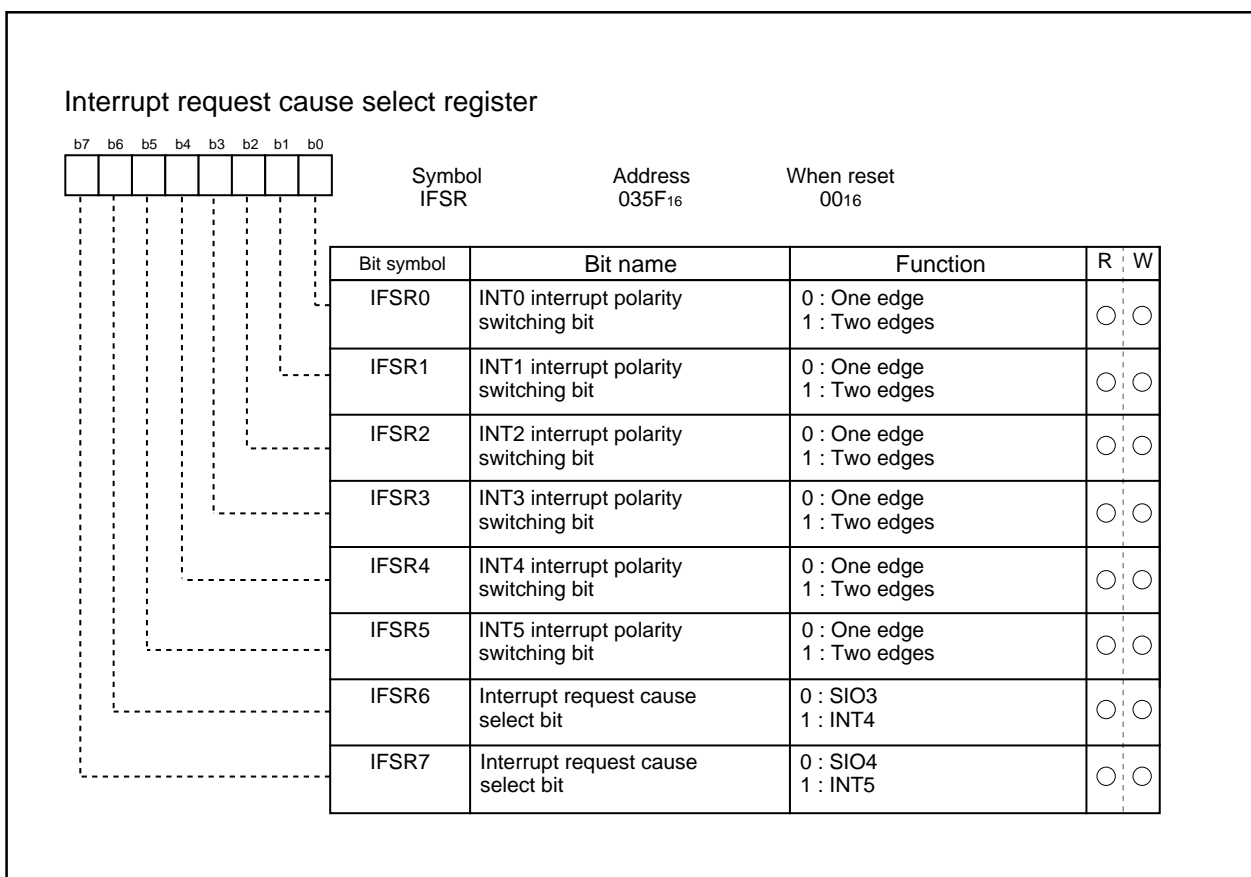

Figure 1.12.10. Interrupt request cause select register

NMI Interrupt

An $\overline{\text{NMI}}$ interrupt is generated when the input to the P85/ $\overline{\text{NMI}}$ pin changes from “H” to “L”. The $\overline{\text{NMI}}$ interrupt is a non-maskable external interrupt. The pin level can be checked in the port P85 register (bit 5 at address 03F016).

This pin cannot be used as a normal port input.

Key Input Interrupt

If the direction register of any of P104 to P107 is set for input and a falling edge is input to that port, a key input interrupt is generated. A key input interrupt can also be used as a key-on wakeup function for canceling the wait mode or stop mode. However, if you intend to use the key input interrupt, do not use P104 to P107 as A-D input ports. Figure 1.12.11 shows the block diagram of the key input interrupt. Note that if an “L” level is input to any pin that has not been disabled for input, inputs to the other pins are not detected as an interrupt.

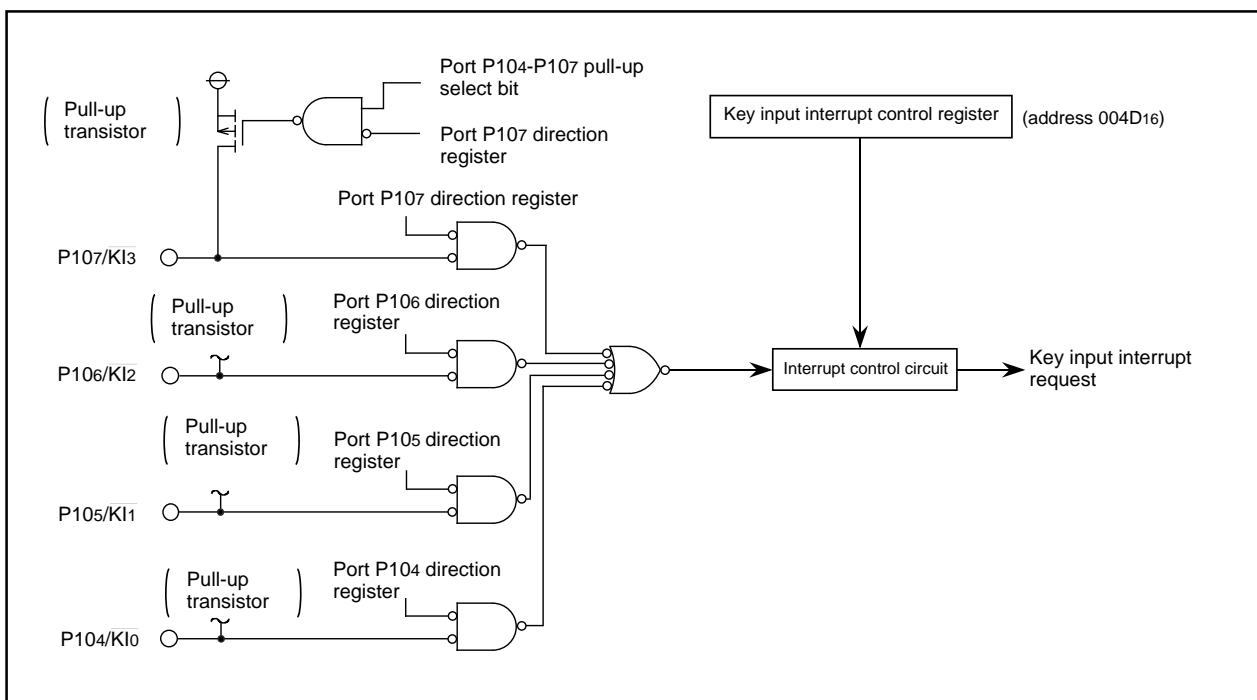

Figure 1.12.11. Block diagram of key input interrupt

Address Match Interrupt

An address match interrupt is generated when the address match interrupt address register contents match the program counter value. Two address match interrupts can be set, each of which can be enabled and disabled by an address match interrupt enable bit. Address match interrupts are not affected by the interrupt enable flag (I flag) and processor interrupt priority level (IPL). For an address match interrupt, the value of the program counter (PC) that is saved to the stack area varies depending on the instruction being executed. Note that when using the external data bus in width of 8 bits, the address match interrupt cannot be used for external area.

Figure 1.12.12 shows the address match interrupt-related registers.

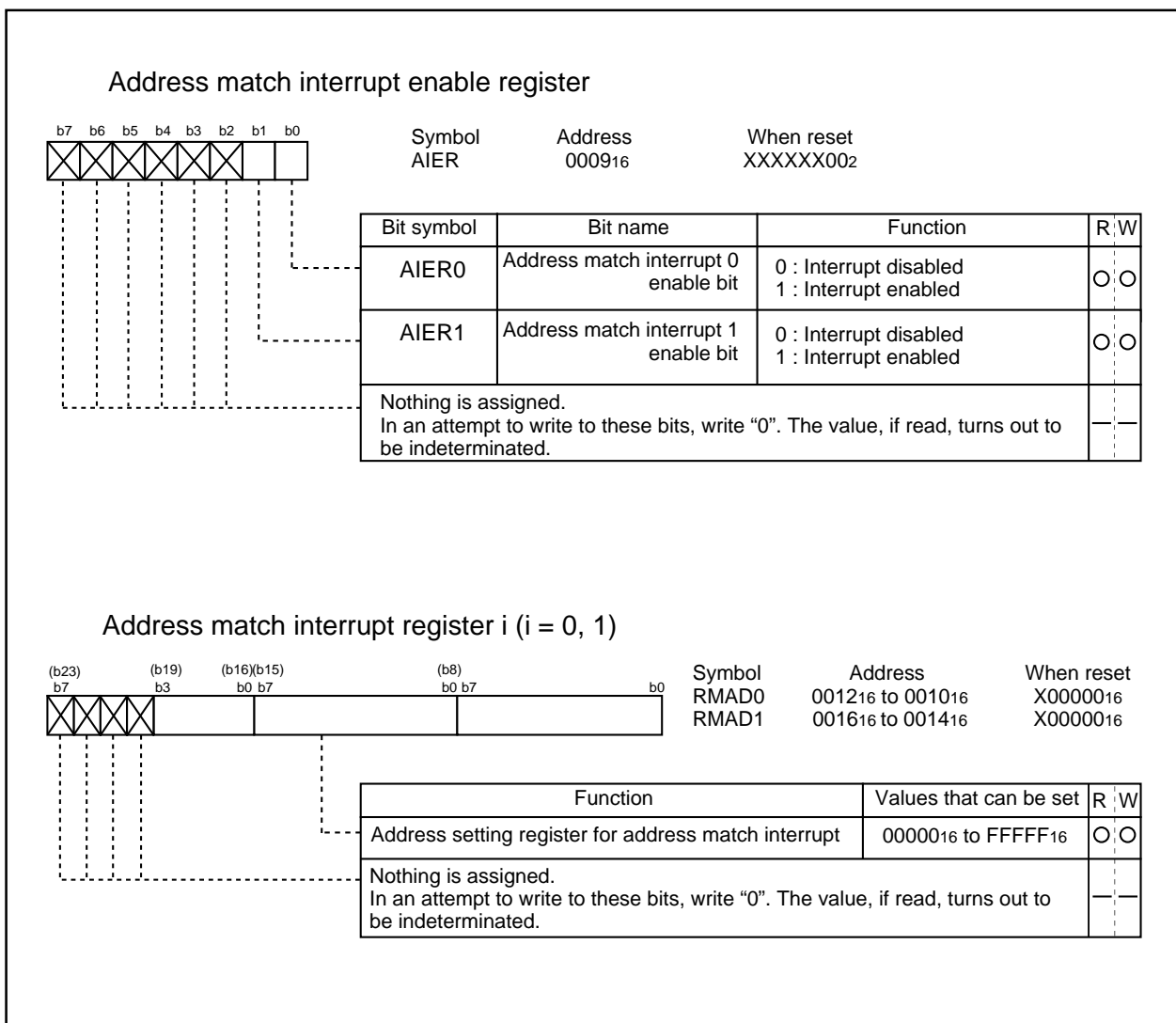

Figure 1.12.12. Address match interrupt-related registers

Precautions for Interrupts

(1) Reading address 00000₁₆

- When maskable interrupt is occurred, CPU reads the interrupt information (the interrupt number and interrupt request level) in the interrupt sequence.

The interrupt request bit of the certain interrupt written in address 00000₁₆ will then be set to "0".

Even if the address 00000₁₆ is read out by software, "0" is set to the enabled highest priority interrupt source request bit. Therefore interrupt can be canceled and unexpected interrupt can occur.

Do not read address 00000₁₆ by software.

(2) Setting the stack pointer

- The value of the stack pointer immediately after reset is initialized to 0000₁₆. Accepting an interrupt before setting a value in the stack pointer may become a factor of runaway. Be sure to set a value in the stack pointer before accepting an interrupt. When using the $\overline{\text{NMI}}$ interrupt, initialize the stack pointer at the beginning of a program. Concerning the first instruction immediately after reset, generating any interrupts including the $\overline{\text{NMI}}$ interrupt is prohibited.

(3) The $\overline{\text{NMI}}$ interrupt

- The $\overline{\text{NMI}}$ interrupt can not be disabled. Be sure to connect $\overline{\text{NMI}}$ pin to Vcc via a pull-up resistor if unused. Be sure to work on it.
- The $\overline{\text{NMI}}$ pin also serves as P85, which is exclusively input. Reading the contents of the P8 register allows reading the pin value. Use the reading of this pin only for establishing the pin level at the time when the $\overline{\text{NMI}}$ interrupt is input.
- Do not attempt to go into stop mode with the input to the $\overline{\text{NMI}}$ pin being in the "L" state. With the input to the $\overline{\text{NMI}}$ being in the "L" state, the CM10 is fixed to "0", so attempting to go into stop mode is turned down.
- Do not attempt to go into wait mode with the input to the $\overline{\text{NMI}}$ pin being in the "L" state. With the input to the $\overline{\text{NMI}}$ pin being in the "L" state, the CPU stops but the oscillation does not stop, so no power is saved. In this instance, the CPU is returned to the normal state by a later interrupt.
- Signals input to the $\overline{\text{NMI}}$ pin require "L" level and "H" level of 2 clock +300ns or more, from the operation clock of the CPU.

(4) External interrupt

- Either an "L" level or an "H" level of at least 250 ns width is necessary for the signal input to pins $\overline{\text{INT}}_0$ through $\overline{\text{INT}}_5$ regardless of the CPU operation clock.
- When the polarity of the $\overline{\text{INT}}_0$ to $\overline{\text{INT}}_5$ pins is changed or the interrupt request cause of the software interrupt numbers 8 to 9 is changed, the interrupt request bit is sometimes set to "1". After these changes were made, set the interrupt request bit to "0". Figure 1.12.13 shows the procedure for changing the $\overline{\text{INT}}$ interrupt generate factor.

(5) Watchdog timer interrupt

- Write to the watchdog timer start register after the watchdog timer interrupt occurs (initialize watchdog timer).

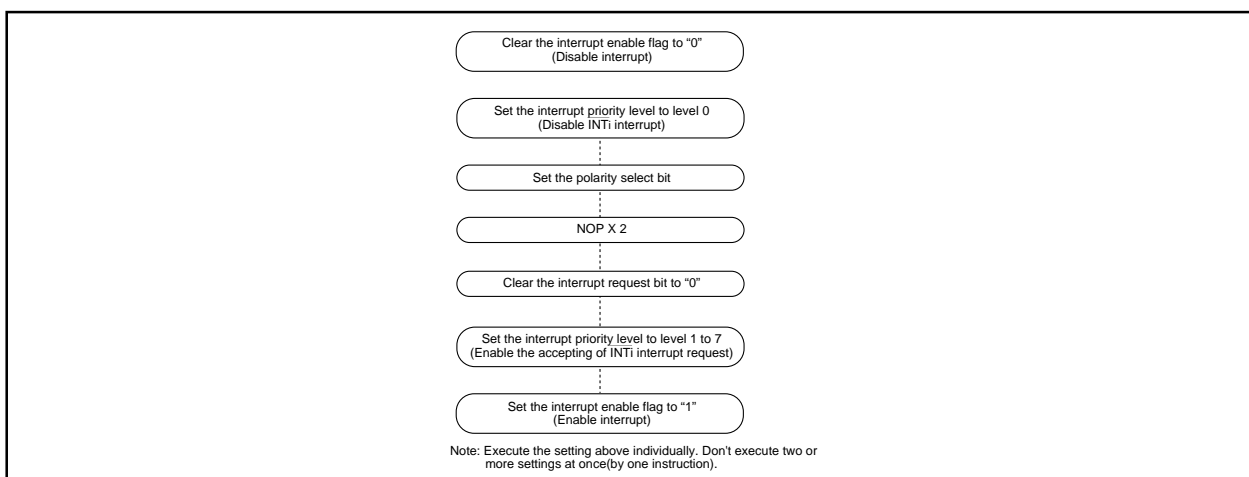
Figure 1.12.13. Switching condition of $\overline{\text{INT}}$ interrupt request

(6) Rewrite the interrupt control register

- To rewrite the interrupt control register, do so at a point that does not generate the interrupt request for that register. If there is possibility of the interrupt request occur, rewrite the interrupt control register after the interrupt is disabled. The program examples are described as follow:

Example 1:

```

INT_SWITCH1:
  FCLR  I           ; Disable interrupts.
  AND.B #00h, 0055h ; Clear TA0IC int. priority level and int. request bit.
  NOP                    ; Four NOP instructions are required when using HOLD function.
  NOP
  FSET  I           ; Enable interrupts.
  
```

Example 2:

```

INT_SWITCH2:
  FCLR  I           ; Disable interrupts.
  AND.B #00h, 0055h ; Clear TA0IC int. priority level and int. request bit.
  MOV.W MEM, R0     ; Dummy read.
  FSET  I           ; Enable interrupts.
  
```

Example 3:

```

INT_SWITCH3:
  PUSHC FLG         ; Push Flag register onto stack
  FCLR  I           ; Disable interrupts.
  AND.B #00h, 0055h ; Clear TA0IC int. priority level and int. request bit.
  POPC  FLG         ; Enable interrupts.
  
```

The reason why two NOP instructions (four when using the HOLD function) or dummy read are inserted before FSET I in Examples 1 and 2 is to prevent the interrupt enable flag I from being set before the interrupt control register is rewritten due to effects of the instruction queue.

When changing an interrupt control register in a state of interrupts being disabled, please read the following precautions on instructions used before changing the register.

(1) Changing a non-interrupt request bit

If an interrupt request for an interrupt control register is generated during an instruction to rewrite the register is being executed, there is a case that the interrupt request bit is not set and consequently the interrupt is ignored. This will depend on the instruction. If this creates problems, use the below instructions to change the register.

Instructions : AND, OR, BCLR, BSET

(2) Changing the interrupt request bit

When attempting to clear the interrupt request bit of an interrupt control register, the interrupt request bit is not cleared sometimes. This will depend on the instruction. If this creates problems, use the below instructions to change the register.

Instructions : MOV

Watchdog Timer

The watchdog timer has the function of detecting when the program is out of control. Therefore, we recommend using the watchdog timer to improve reliability of a system. The watchdog timer is a 15-bit counter which down-counts the clock derived by dividing the BCLK using the prescaler. Whether a watchdog timer interrupt is generated or reset is selected when an underflow occurs in the watchdog timer. When the watchdog timer interrupt is selected, write to the watchdog timer start register after the watchdog timer interrupt occurs (initialize watchdog timer). Watchdog timer interrupt is selected when bit 2 (PM12) of the processor mode register 1 (address 0005₁₆) is "0" and reset is selected when PM12 is "1". No value other than "1" can be written in PM12. Once when reset is selected (PM12="1"), watchdog timer interrupt cannot be selected by software.

When X_{IN} is selected for the BCLK, bit 7 of the watchdog timer control register (address 000F₁₆) selects the prescaler division ratio (by 16 or by 128). When X_{CIN} is selected as the BCLK, the prescaler is set for division by 2 regardless of bit 7 of the watchdog timer control register (address 000F₁₆). Thus the watchdog timer's period can be calculated as given below. The watchdog timer's period is, however, subject to an error due to the prescaler.

With X_{IN} chosen for BCLK

$$\text{Watchdog timer period} = \frac{\text{prescaler dividing ratio (16 or 128)} \times \text{watchdog timer count (32768)}}{\text{BCLK}}$$

With X_{CIN} chosen for BCLK

$$\text{Watchdog timer period} = \frac{\text{prescaler dividing ratio (2)} \times \text{watchdog timer count (32768)}}{\text{BCLK}}$$

For example, suppose that BCLK runs at 16 MHz and that 16 has been chosen for the dividing ratio of the prescaler, then the watchdog timer's period becomes approximately 32.8 ms.

The watchdog timer is initialized by writing to the watchdog timer start register (address 000E₁₆) and when a watchdog timer interrupt request is generated. The prescaler is initialized only when the microcomputer is reset. After a reset is cancelled, the watchdog timer and prescaler are both stopped. The count is started by writing to the watchdog timer start register (address 000E₁₆). In stop mode, wait mode and hold state, the watchdog timer and prescaler are stopped. Counting is resumed from the held value when the modes or state are released.

Also PM12 is initialized only when reset. The watchdog timer interrupt is selected after reset is cancelled. Figure 1.13.1 shows the block diagram of the watchdog timer. Figure 1.13.2 shows the watchdog timer-related registers.

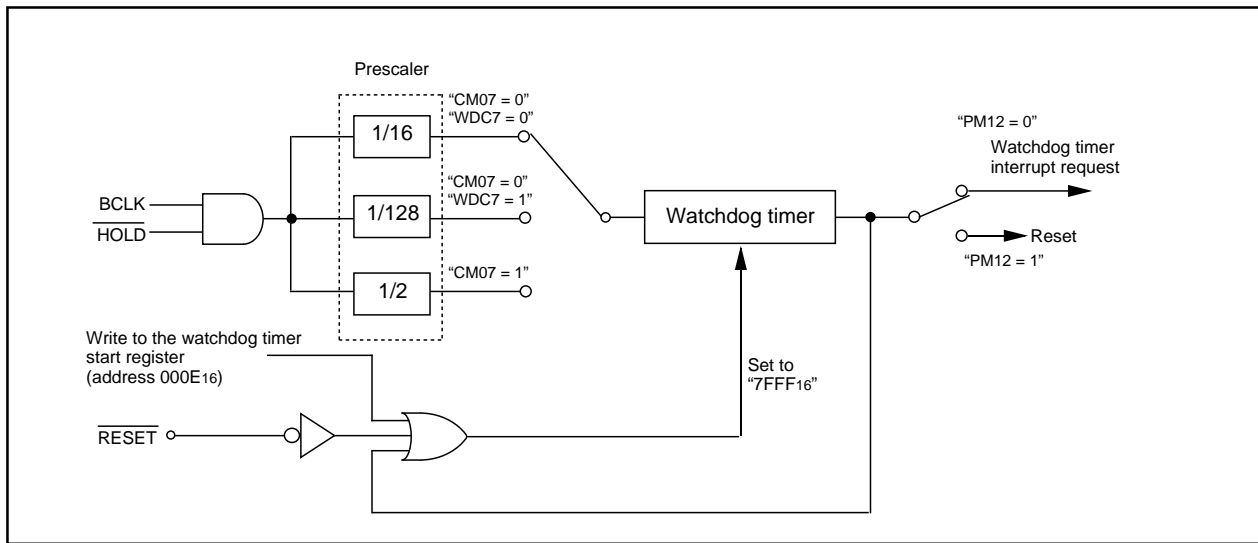

Figure 1.13.1. Block diagram of watchdog timer

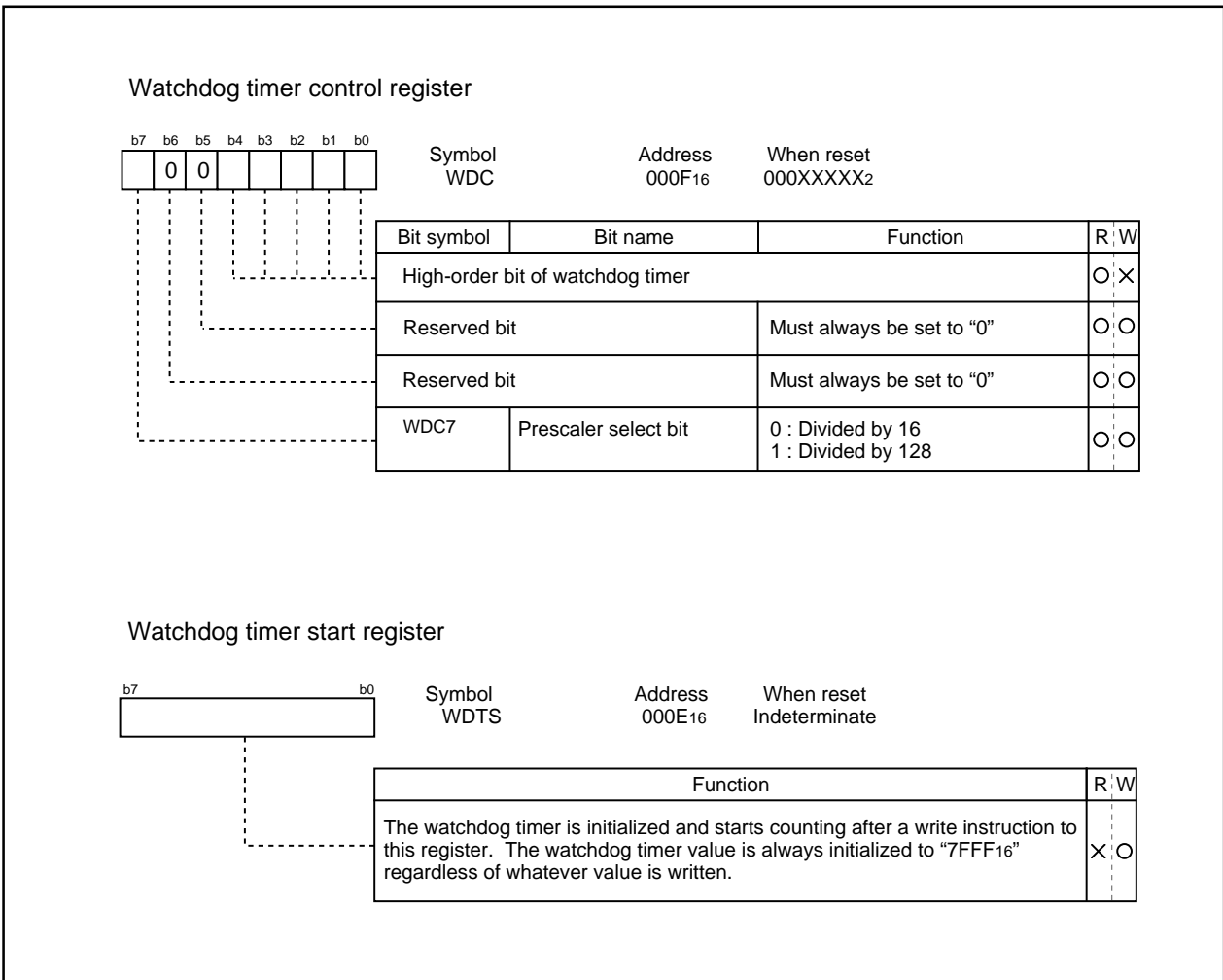

Figure 1.13.2. Watchdog timer control and start registers

DMAC

This microcomputer has two DMAC (direct memory access controller) channels that allow data to be sent to memory without using the CPU. DMAC shares the same data bus with the CPU. The DMAC is given a higher right of using the bus than the CPU, which leads to working the cycle stealing method. On this account, the operation from the occurrence of DMA transfer request signal to the completion of 1-word (16-bit) or 1-byte (8-bit) data transfer can be performed at high speed. Figure 1.14.1 shows the block diagram of the DMAC. Table 1.14.1 shows the DMAC specifications. Figures 1.14.2 to 1.14.4 show the registers used by the DMAC.

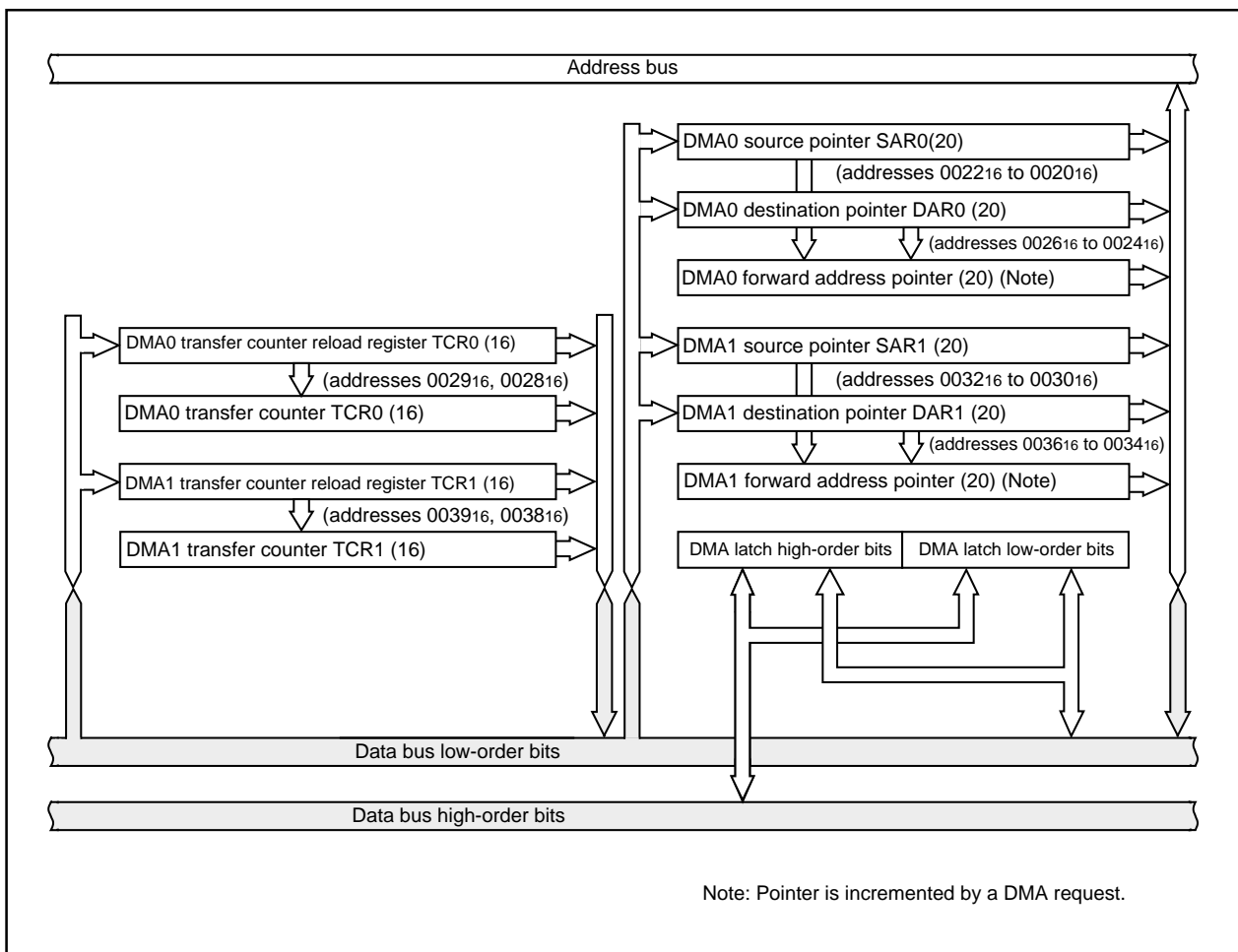

Figure 1.14.1. Block diagram of DMAC

Either a write signal to the software DMA request bit or an interrupt request signal is used as a DMA transfer request signal. But the DMA transfer is affected neither by the interrupt enable flag (I flag) nor by the interrupt priority level. The DMA transfer doesn't affect any interrupts either.

If the DMAC is active (the DMA enable bit is set to 1), data transfer starts every time a DMA transfer request signal occurs. If the cycle of the occurrences of DMA transfer request signals is higher than the DMA transfer cycle, there can be instances in which the number of transfer requests doesn't agree with the number of transfers. For details, see the description of the DMA request bit.

Table 1.14.1. DMAC specifications

Item	Specification
No. of channels	2 (cycle steal method)
Transfer memory space	<ul style="list-style-type: none"> • From any address in the 1M bytes space to a fixed address • From a fixed address to any address in the 1M bytes space • From a fixed address to a fixed address (Note that DMA-related registers [0020 ₁₆ to 003F ₁₆] cannot be accessed)
Maximum No. of bytes transferred	128K bytes (with 16-bit transfers) or 64K bytes (with 8-bit transfers)
DMA request factors (Note)	Falling edge of $\overline{INT0}$ or $\overline{INT1}$ or both edge Timer A0 to timer A4 interrupt requests Timer B0 to timer B5 interrupt requests UART0 transfer and reception interrupt requests UART1 transfer and reception interrupt requests UART2 transfer and reception interrupt requests Serial I/O3, 4 interrupt requests A-D conversion interrupt requests Software triggers
Channel priority	DMA0 takes precedence if DMA0 and DMA1 requests are generated simultaneously
Transfer unit	8 bits or 16 bits
Transfer address direction	forward/fixed (forward direction cannot be specified for both source and destination simultaneously)
Transfer mode	<ul style="list-style-type: none"> • Single transfer mode After the transfer counter underflows, the DMA enable bit turns to "0", and the DMAC turns inactive • Repeat transfer mode After the transfer counter underflows, the value of the transfer counter reload register is reloaded to the transfer counter. The DMAC remains active unless a "0" is written to the DMA enable bit.
DMA interrupt request generation timing	When an underflow occurs in the transfer counter
Active	When the DMA enable bit is set to "1", the DMAC is active. When the DMAC is active, data transfer starts every time a DMA transfer request signal occurs.
Inactive	<ul style="list-style-type: none"> • When the DMA enable bit is set to "0", the DMAC is inactive. • After the transfer counter underflows in single transfer mode
Reload timing for forward address pointer and transfer counter	At the time of starting data transfer immediately after turning the DMAC active, the value of one of source pointer and destination pointer - the one specified for the forward direction - is reloaded to the forward direction address pointer, and the value of the transfer counter reload register is reloaded to the transfer counter.
Writing to register	Registers specified for forward direction transfer are always write enabled. Registers specified for fixed address transfer are write-enabled when the DMA enable bit is "0".
Reading the register	Can be read at any time. However, when the DMA enable bit is "1", reading the register set up as the forward register is the same as reading the value of the forward address pointer.

Note: DMA transfer is not effective to any interrupt. DMA transfer is affected neither by the interrupt enable flag (I flag) nor by the interrupt priority level.

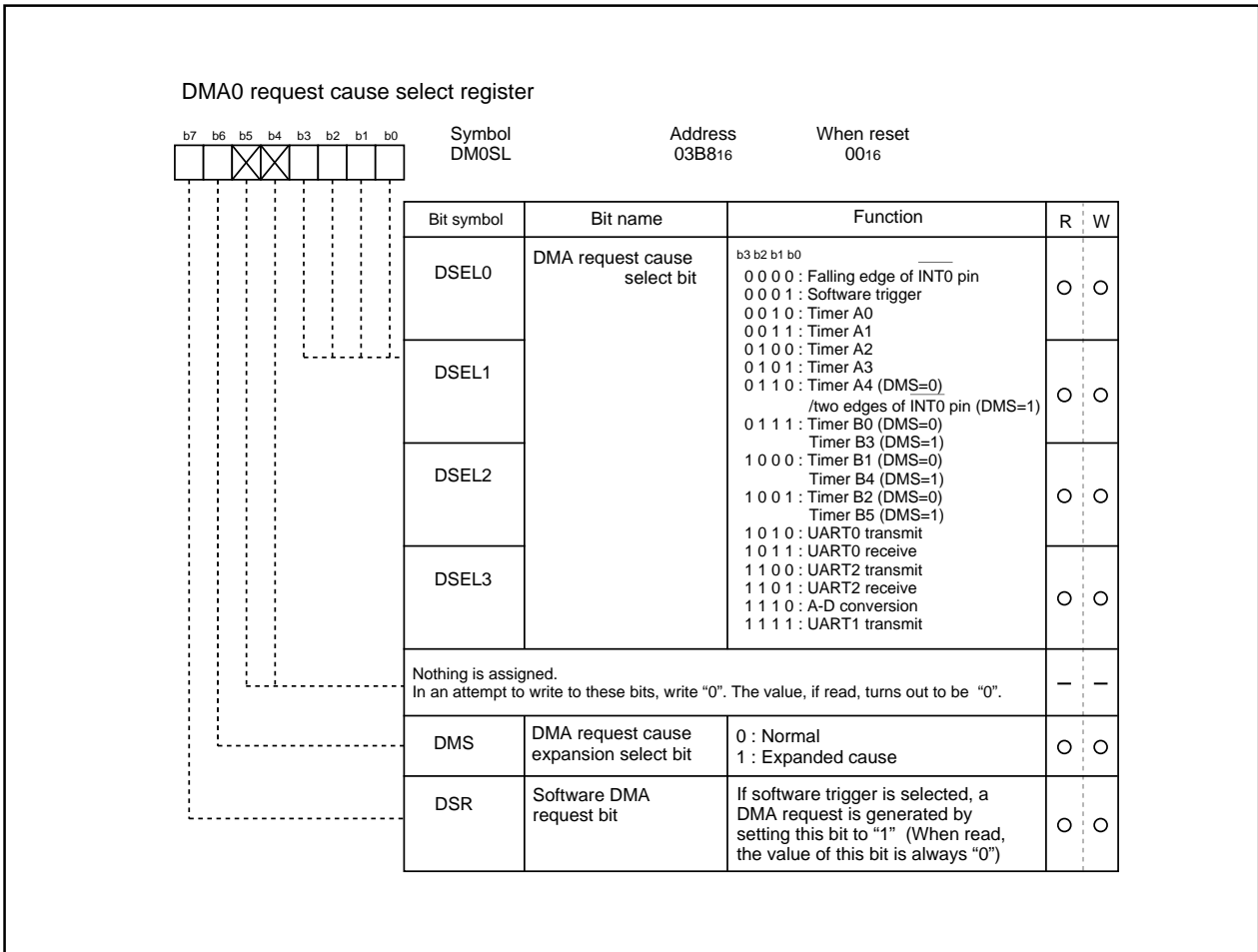

Figure 1.14.2. DMAC register (1)

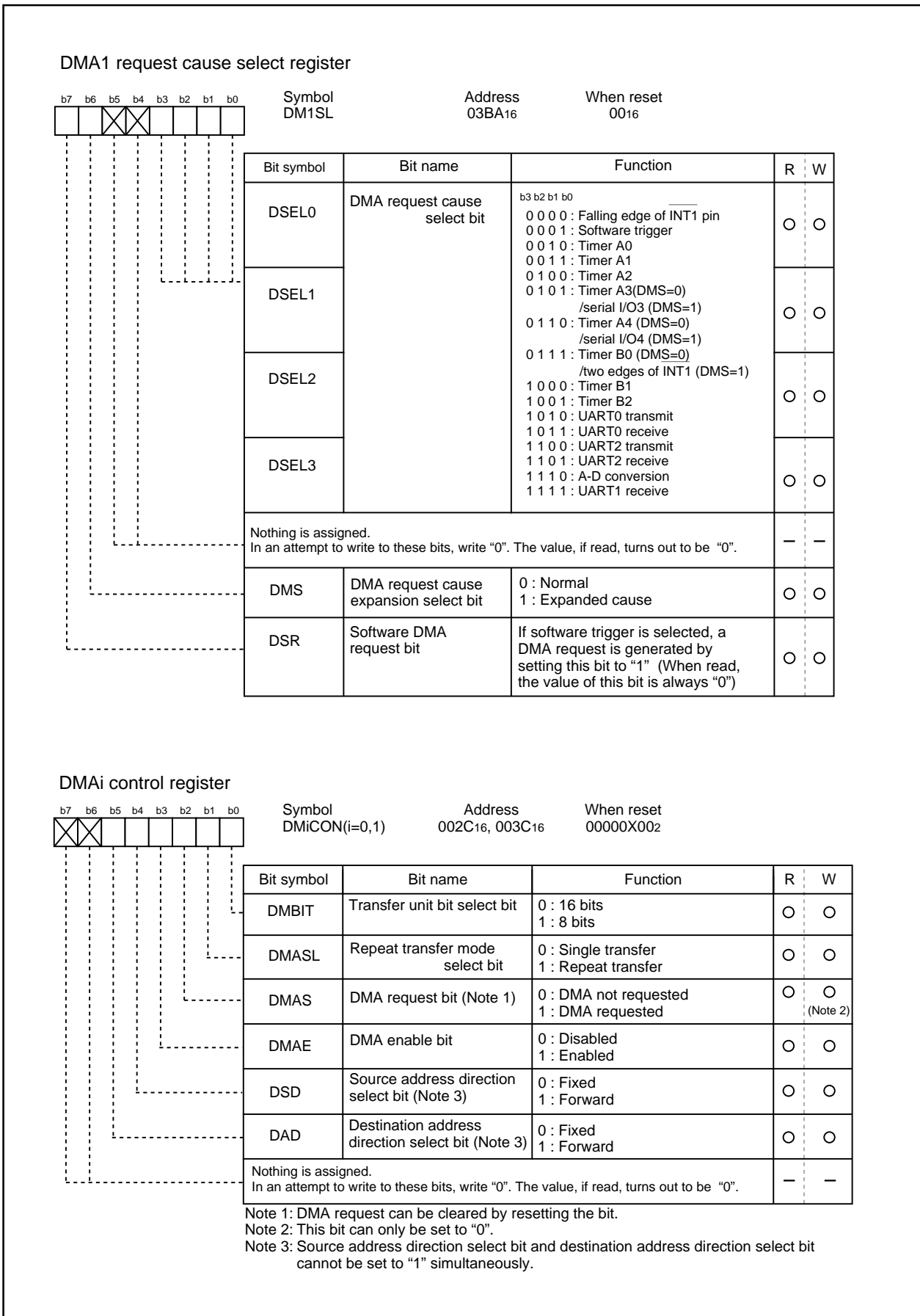

Figure 1.14.3. DMAC register (2)

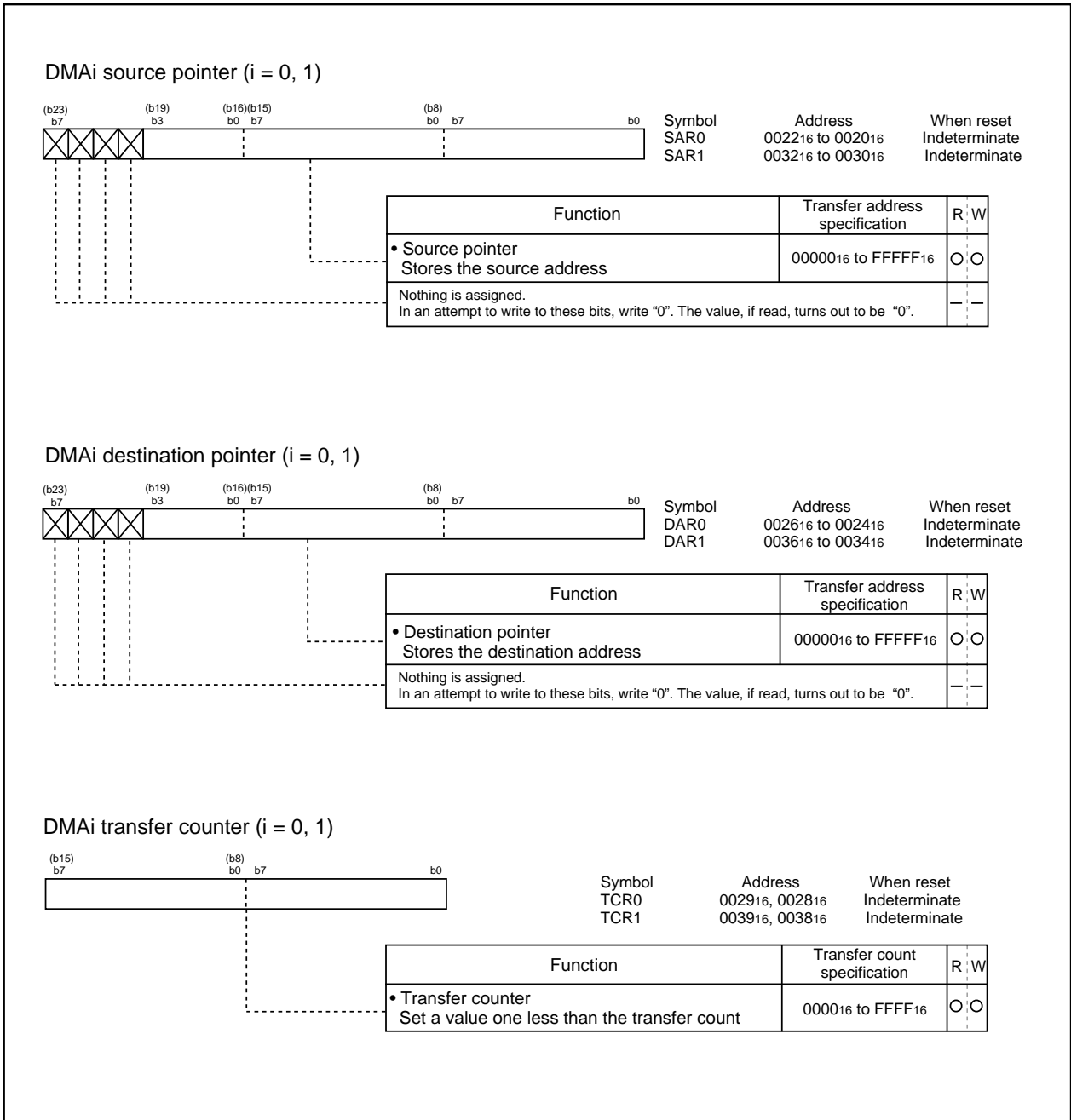

Figure 1.14.4. DMAC register (3)

(1) Transfer cycle

The transfer cycle consists of the bus cycle in which data is read from memory or from the SFR area (source read) and the bus cycle in which the data is written to memory or to the SFR area (destination write). The number of read and write bus cycles depends on the source and destination addresses. In memory expansion mode and microprocessor mode, the number of read and write bus cycles also depends on the level of the BYTE pin. Also, the bus cycle itself is longer when software waits are inserted.

(a) Effect of source and destination addresses

When 16-bit data is transferred on a 16-bit data bus, and the source and destination both start at odd addresses, there are one more source read cycle and destination write cycle than when the source and destination both start at even addresses.

(b) Effect of BYTE pin level

When transferring 16-bit data over an 8-bit data bus (BYTE pin = "H") in memory expansion mode and microprocessor mode, the 16 bits of data are sent in two 8-bit blocks. Therefore, two bus cycles are required for reading the data and two are required for writing the data. Also, in contrast to when the CPU accesses internal memory, when the DMAC accesses internal memory (internal ROM, internal RAM, and SFR), these areas are accessed using the data size selected by the BYTE pin.

(c) Effect of software wait

When the SFR area or a memory area with a software wait is accessed, the number of cycles is increased for the wait by 1 bus cycle. The length of the cycle is determined by BCLK.

Figure 1.14.5 shows the example of the transfer cycles for a source read. For convenience, the destination write cycle is shown as one cycle and the source read cycles for the different conditions are shown. In reality, the destination write cycle is subject to the same conditions as the source read cycle, with the transfer cycle changing accordingly. When calculating the transfer cycle, remember to apply the respective conditions to both the destination write cycle and the source read cycle. For example (2) in Figure 1.14.5, if data is being transferred in 16-bit units on an 8-bit bus, two bus cycles are required for both the source read cycle and the destination write cycle.

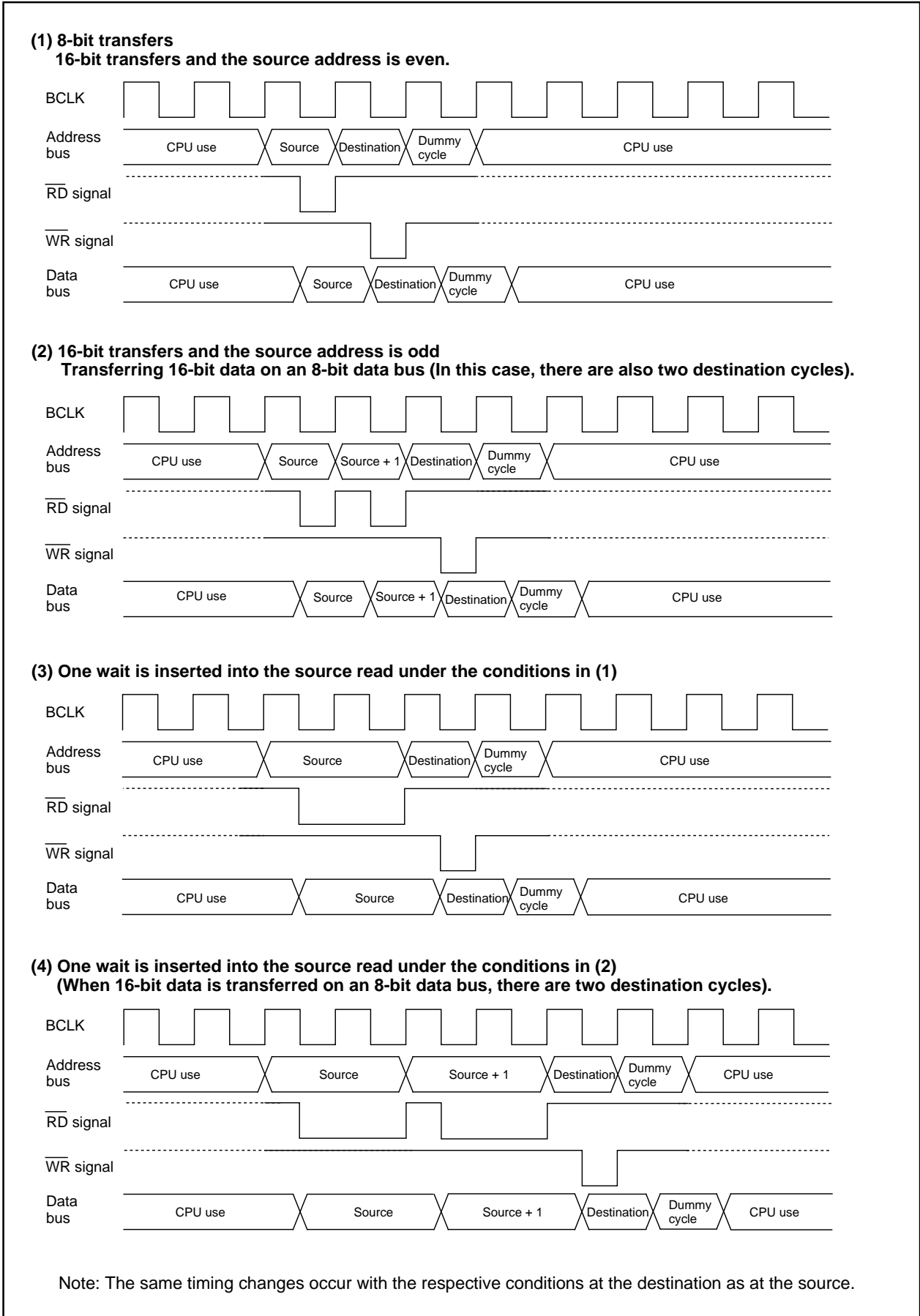

Figure 1.14.5. Example of the transfer cycles for a source read

(2) DMAC transfer cycles

Any combination of even or odd transfer read and write addresses is possible. Table 1.14.2 shows the number of DMAC transfer cycles.

The number of DMAC transfer cycles can be calculated as follows:

$$\text{No. of transfer cycles per transfer unit} = \text{No. of read cycles} \times j + \text{No. of write cycles} \times k$$

Table 1.14.2. No. of DMAC transfer cycles

Transfer unit	Bus width	Access address	Single-chip mode		Memory expansion mode Microprocessor mode	
			No. of read cycles	No. of write cycles	No. of read cycles	No. of write cycles
8-bit transfers (DMBIT= "1")	16-bit (BYTE= "L")	Even	1	1	1	1
		Odd	1	1	1	1
	8-bit (BYTE = "H")	Even	—	—	1	1
		Odd	—	—	1	1
16-bit transfers (DMBIT= "0")	16-bit (BYTE = "L")	Even	1	1	1	1
		Odd	2	2	2	2
	8-bit (BYTE = "H")	Even	—	—	2	2
		Odd	—	—	2	2

Coefficient j, k

Internal memory			External memory		
Internal ROM/RAM No wait	Internal ROM/RAM With wait	SFR area	Separate bus No wait	Separate bus With wait	Multiplex bus
1	2	2	1	2	3

DMA enable bit

Setting the DMA enable bit to “1” makes the DMAC active. The DMAC carries out the following operations at the time data transfer starts immediately after DMAC is turned active.

- (1) Reloads the value of one of the source pointer and the destination pointer - the one specified for the forward direction - to the forward direction address pointer.
- (2) Reloads the value of the transfer counter reload register to the transfer counter.

Thus overwriting “1” to the DMA enable bit with the DMAC being active carries out the operations given above, so the DMAC operates again from the initial state at the instant “1” is overwritten to the DMA enable bit.

DMA request bit

The DMAC can generate a DMA transfer request signal triggered by a factor chosen in advance out of DMA request factors for each channel.

DMA request factors include the following.

* Factors effected by using the interrupt request signals from the built-in peripheral functions and software DMA factors (internal factors) effected by a program.

* External factors effected by utilizing the input from external interrupt signals.

For the selection of DMA request factors, see the descriptions of the DMA_i factor selection register.

The DMA request bit turns to “1” if the DMA transfer request signal occurs regardless of the DMAC's state (regardless of whether the DMA enable bit is set to “1” or “0”). It turns to “0” immediately before data transfer starts.

In addition, it can be set to “0” by use of a program, but cannot be set to “1”.

There can be instances in which a change in DMA request factor selection bit causes the DMA request bit to turn to “1”. So be sure to set the DMA request bit to “0” after the DMA request factor selection bit is changed.

The DMA request bit turns to “1” if a DMA transfer request signal occurs, and turns to “0” immediately before data transfer starts. If the DMAC is active, data transfer starts immediately, so the value of the DMA request bit, if read by use of a program, turns out to be “0” in most cases. To examine whether the DMAC is active, read the DMA enable bit.

Here follows the timing of changes in the DMA request bit.

(1) Internal factors

Except the DMA request factors triggered by software, the timing for the DMA request bit to turn to “1” due to an internal factor is the same as the timing for the interrupt request bit of the interrupt control register to turn to “1” due to several factors.

Turning the DMA request bit to “0” due to an internal factor is timed to be effected immediately before the transfer starts.

(2) External factors

An external factor is a factor caused to occur by the leading edge of input from the $\overline{\text{INT}}_i$ pin (i depends on which DMAC channel is used).

Selecting the $\overline{\text{INT}}_i$ pins as external factors using the DMA request factor selection bit causes input from these pins to become the DMA transfer request signals.

The timing for the DMA request bit to turn to “1” when an external factor is selected synchronizes with the signal's edge applicable to the function specified by the DMA request factor selection bit (synchronizes with the trailing edge of the input signal to each $\overline{\text{INT}}_i$ pin, for example).

With an external factor selected, the DMA request bit is timed to turn to “0” immediately before data transfer starts similarly to the state in which an internal factor is selected.

(3) The priorities of channels and DMA transfer timing

If a DMA transfer request signal falls on a single sampling cycle (a sampling cycle means one period from the leading edge to the trailing edge of BCLK), the DMA request bits of applicable channels concurrently turn to "1". If the channels are active at that moment, DMA0 is given a high priority to start data transfer. When DMA0 finishes data transfer, it gives the bus right to the CPU. When the CPU finishes single bus access, then DMA1 starts data transfer and gives the bus right to the CPU.

An example in which DMA transfer is carried out in minimum cycles at the time when DMA transfer request signals due to external factors concurrently occur.

Figure 1.14.6 shows the DMA transfer effected by external factors.

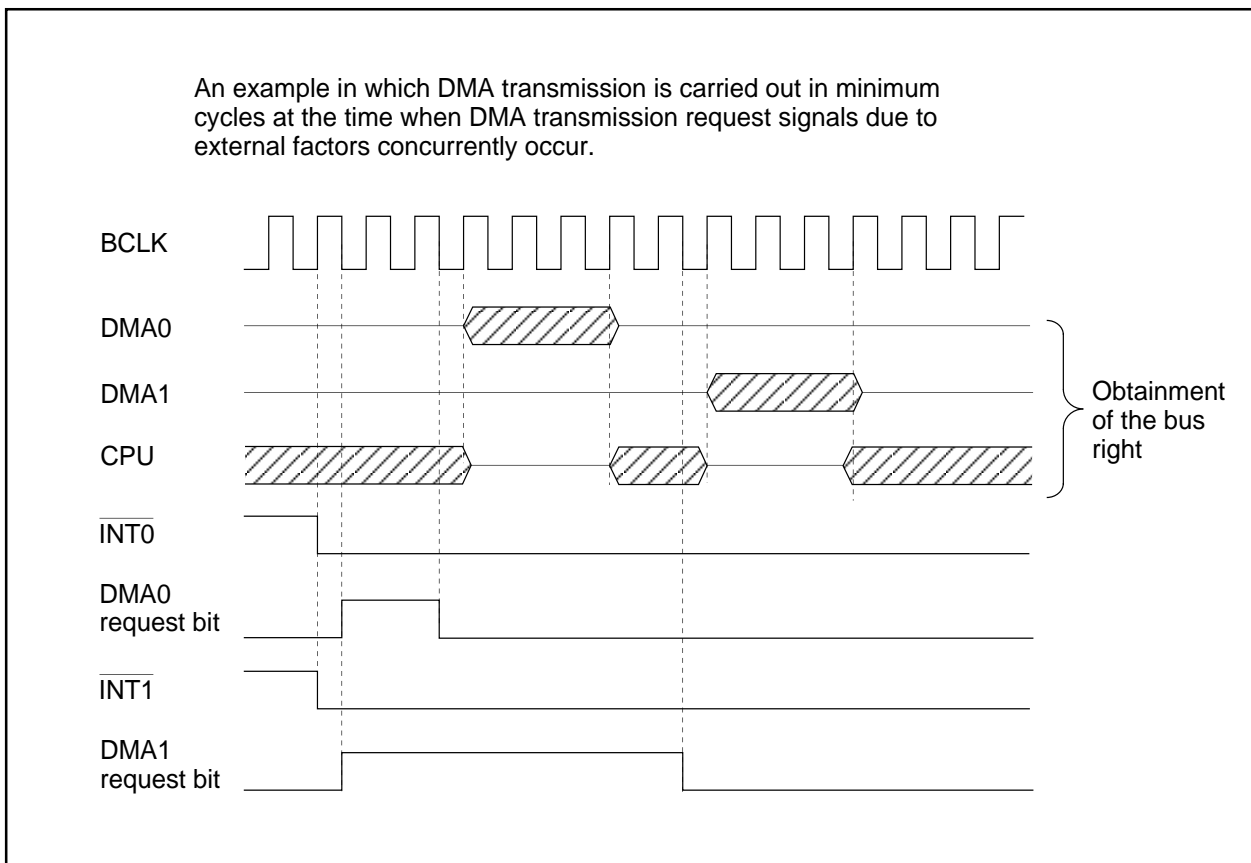

Figure 1.14.6. An example of DMA transfer effected by external factors

Timer

Timer

There are eleven 16-bit timers. These timers can be classified by function into timers A (five) and timers B (six). All these timers function independently. Figures 1.15.1 and 1.15.2 show the block diagram of timers.

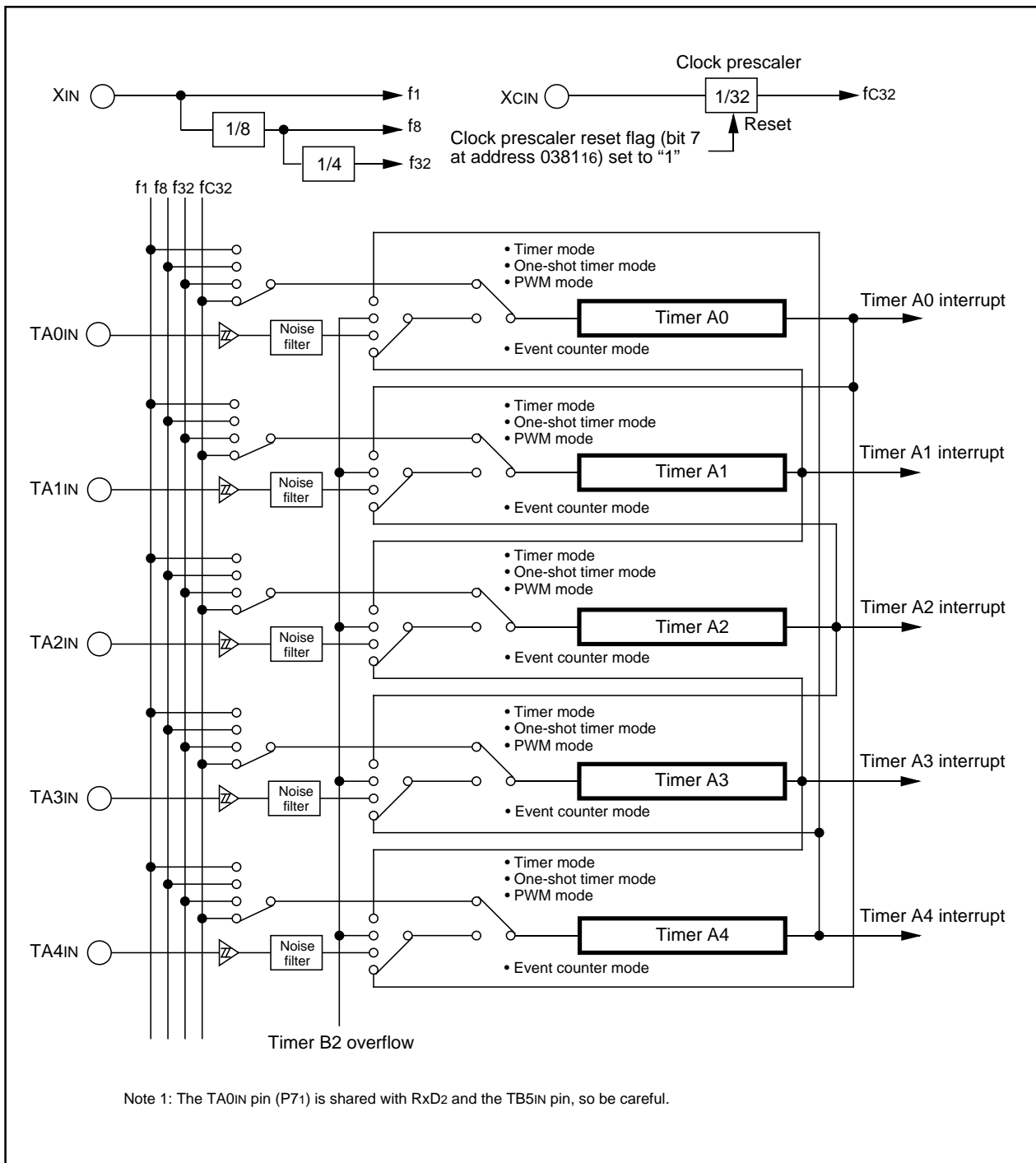

Figure 1.15.1. Timer A block diagram

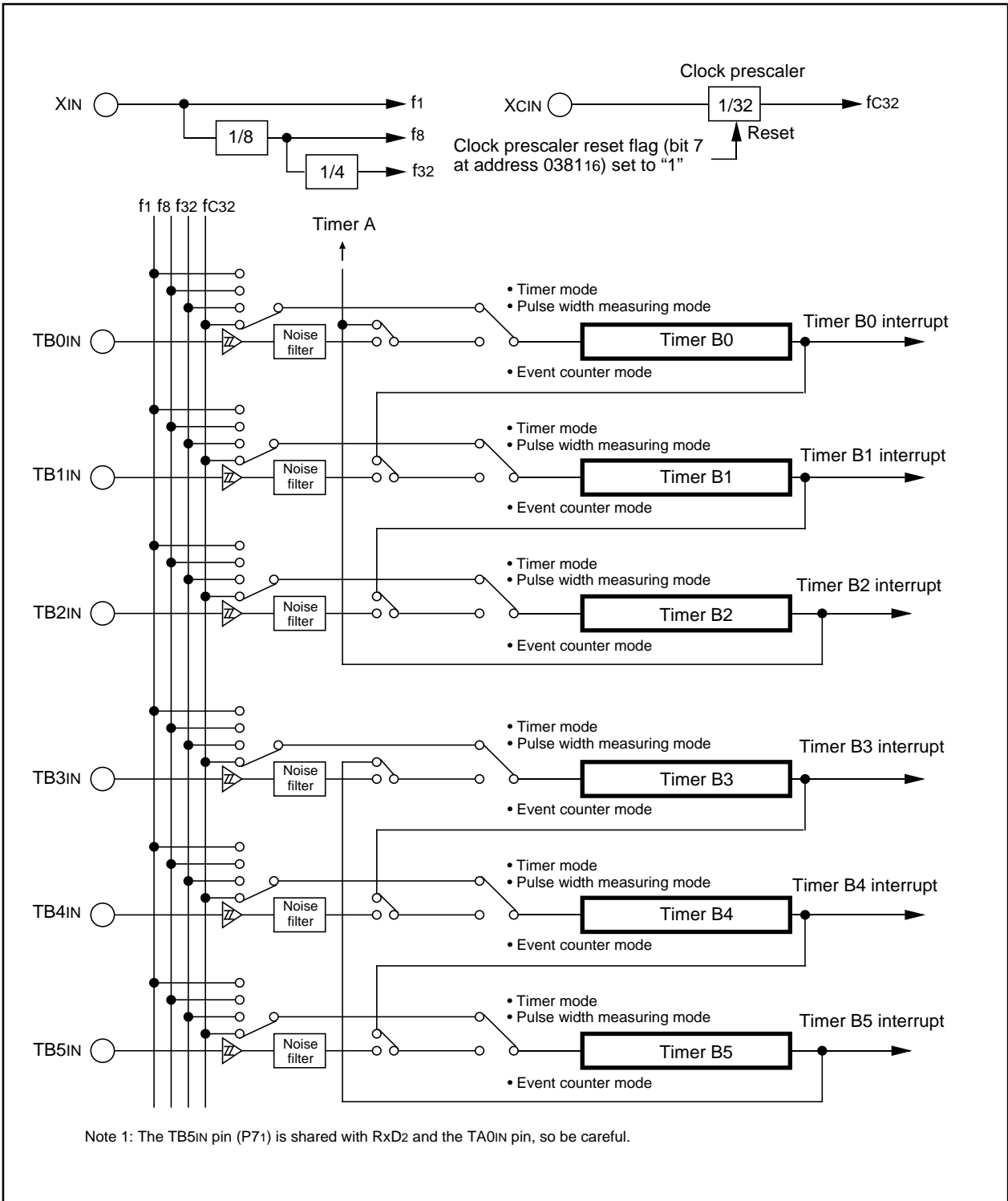

Figure 1.15.2. Timer B block diagram

Timer A

Timer A

Figure 1.15.3 shows the block diagram of timer A. Figures 1.15.4 to 1.15.6 show the timer A-related registers.

Except in event counter mode, timers A0 through A4 all have the same function. Use the timer Ai mode register (i = 0 to 4) bits 0 and 1 to choose the desired mode.

Timer A has the four operation modes listed as follows:

- Timer mode: The timer counts an internal count source.
- Event counter mode: The timer counts pulses from an external source or a timer over flow.
- One-shot timer mode: The timer stops counting when the count reaches "000016".
- Pulse width modulation (PWM) mode: The timer outputs pulses of a given width.

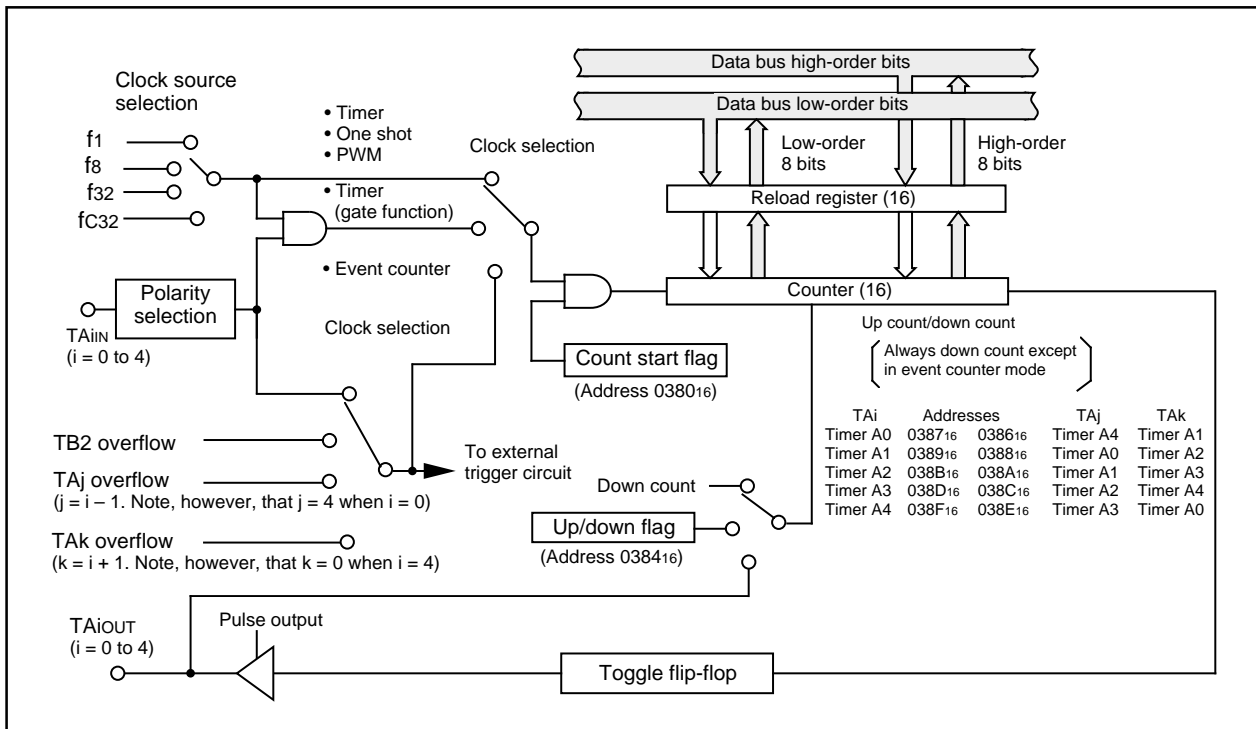

Figure 1.15.3. Block diagram of timer A

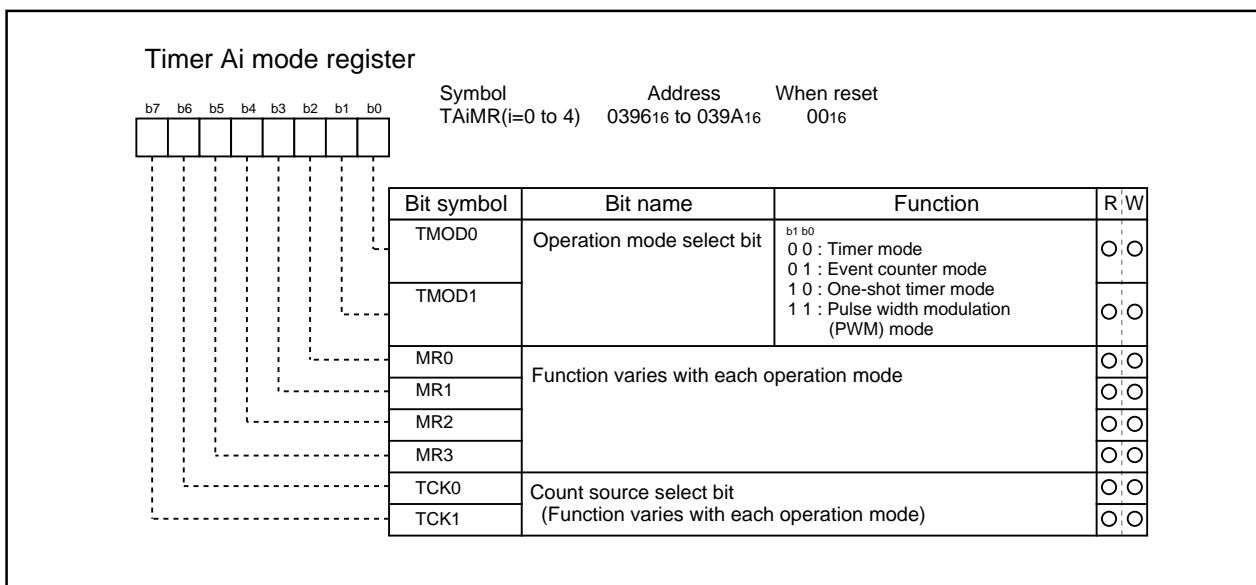

Figure 1.15.4. Timer A-related registers (1)

Timer A

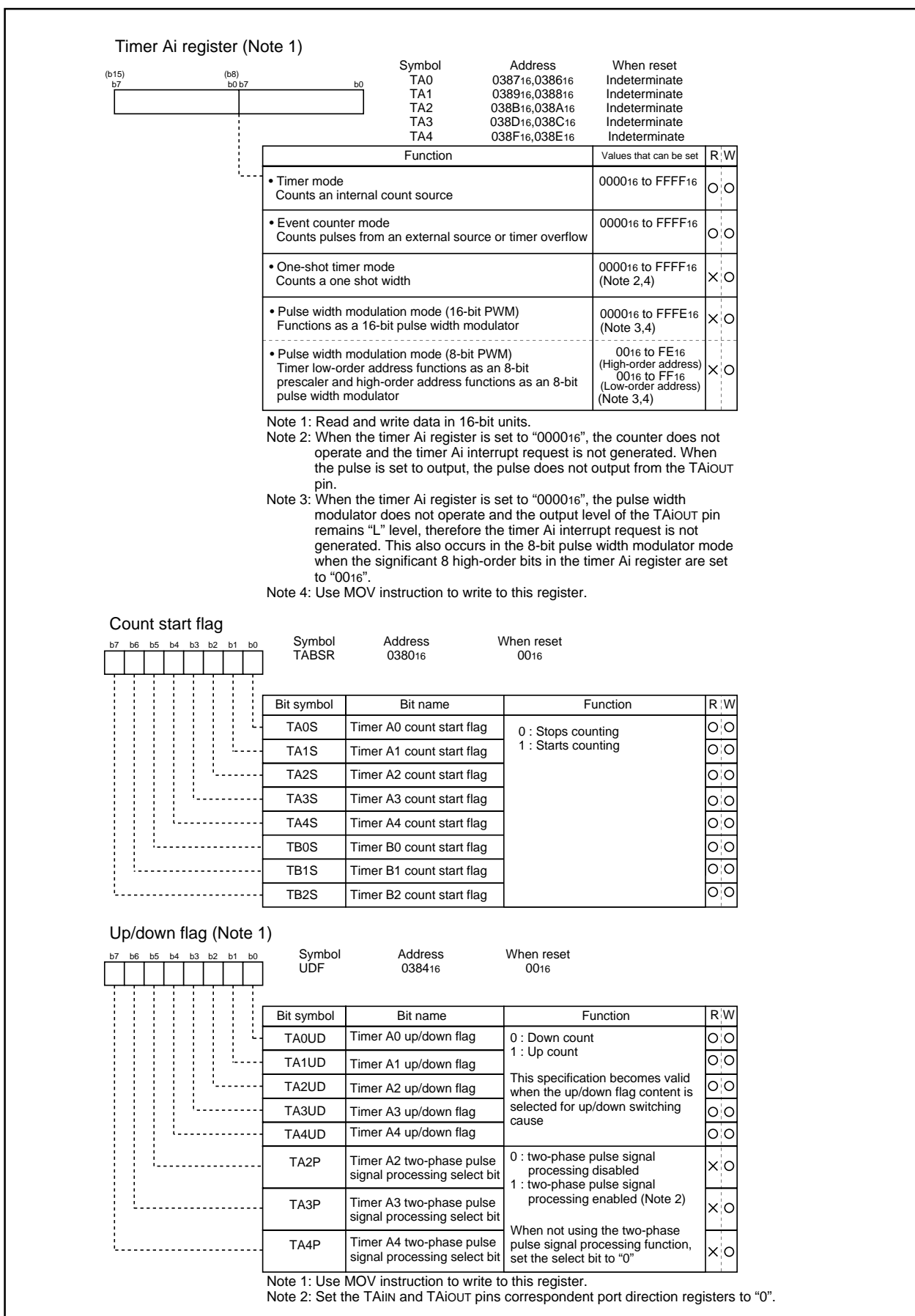

Figure 1.15.5. Timer A-related registers (2)

Timer A

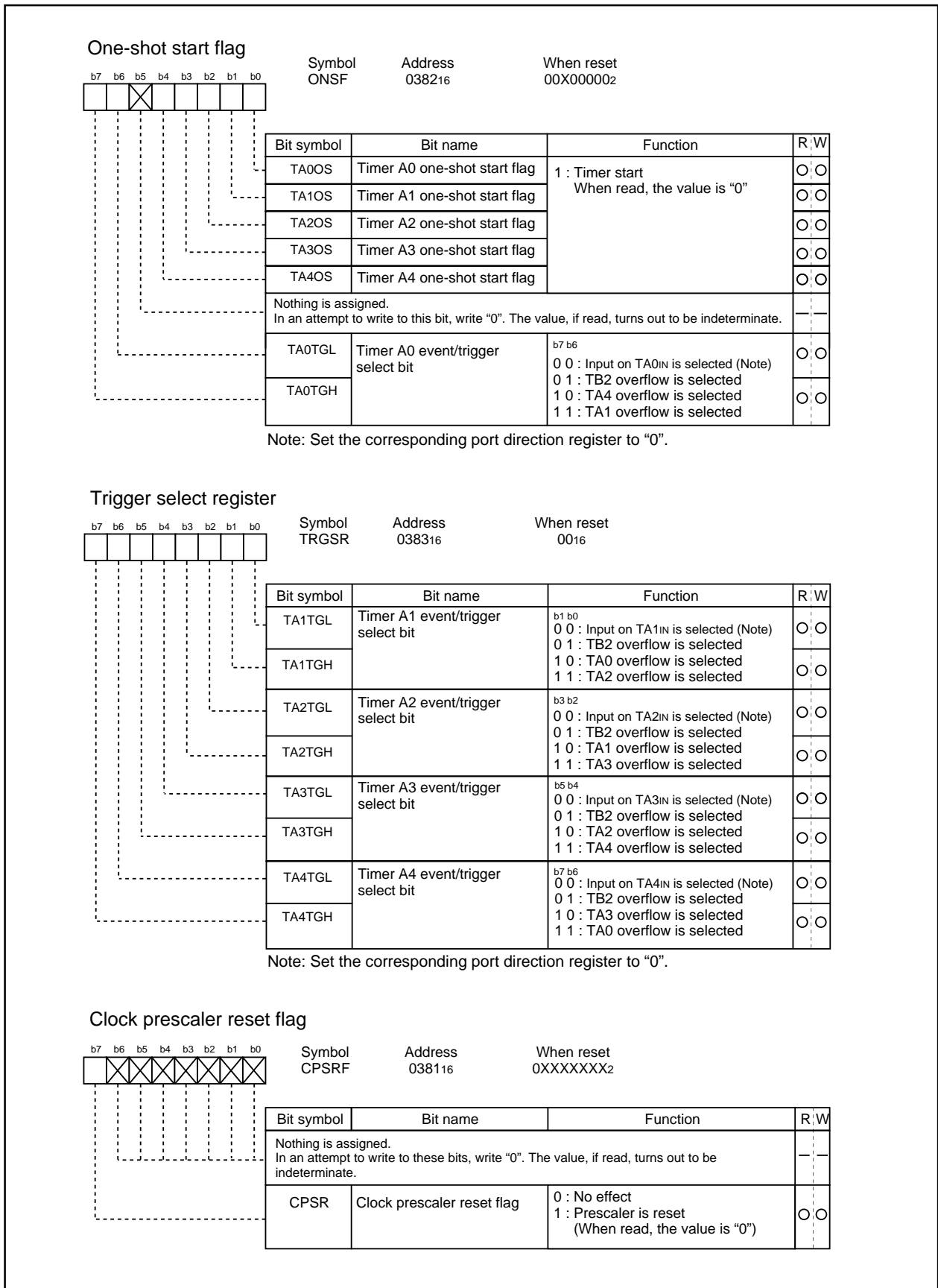

Figure 1.15.6. Timer A-related registers (3)

(1) Timer mode

In this mode, the timer counts an internally generated count source. (See Table 1.15.1.) Figure 1.15.7 shows the timer Ai mode register in timer mode.

Table 1.15.1. Specifications of timer mode

Item	Specification
Count source	f1, f8, f32, fc32
Count operation	<ul style="list-style-type: none"> • Down count • When the timer underflows, it reloads the reload register contents before continuing counting
Divide ratio	1/(n+1) n : Set value
Count start condition	Count start flag is set (= 1)
Count stop condition	Count start flag is reset (= 0)
Interrupt request generation timing	When the timer underflows
TAiIN pin function	Programmable I/O port or gate input
TAiOUT pin function	Programmable I/O port or pulse output
Read from timer	Count value can be read out by reading timer Ai register
Write to timer	<ul style="list-style-type: none"> • When counting stopped When a value is written to timer Ai register, it is written to both reload register and counter • When counting in progress When a value is written to timer Ai register, it is written to only reload register (Transferred to counter at next reload time)
Select function	<ul style="list-style-type: none"> • Gate function Counting can be started and stopped by the TAiIN pin's input signal • Pulse output function Each time the timer underflows, the TAiOUT pin's polarity is reversed

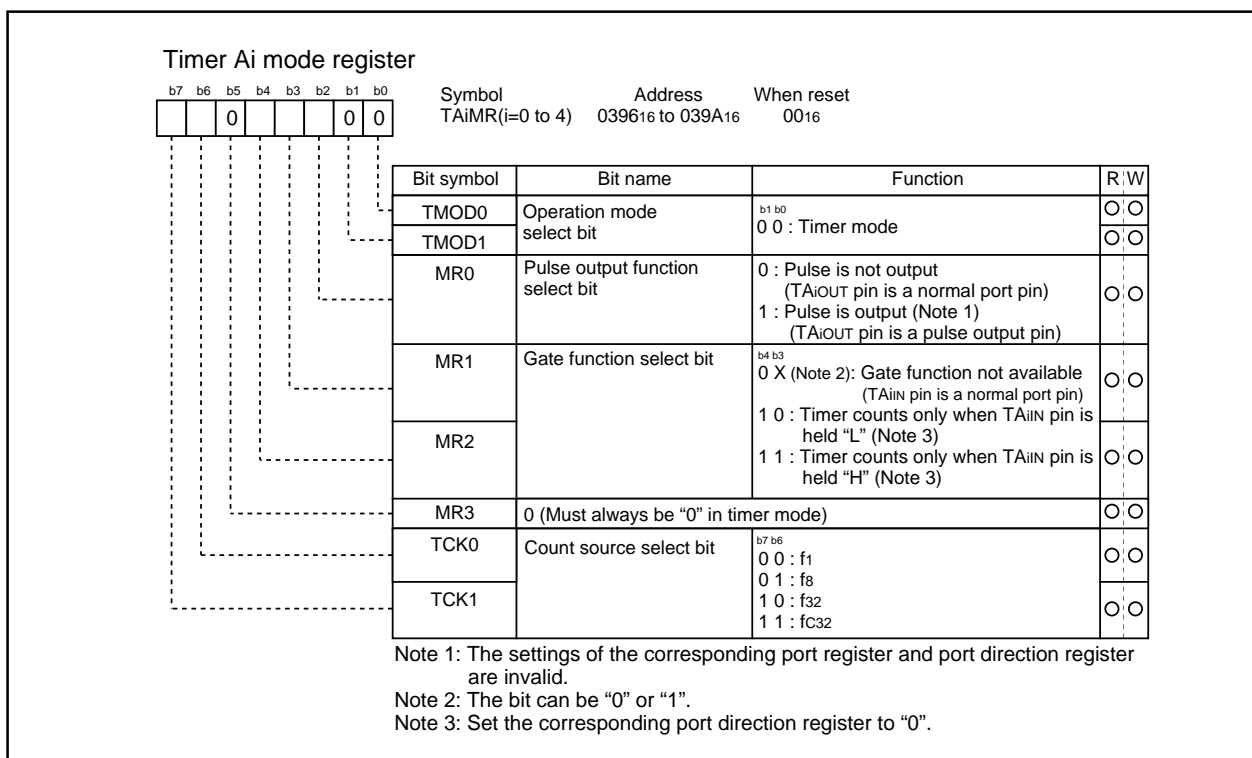

Figure 1.15.7. Timer Ai mode register in timer mode

(2) Event counter mode

In this mode, the timer counts an external signal or an internal timer's overflow. Timers A0 and A1 can count a single-phase external signal. Timers A2, A3, and A4 can count a single-phase and a two-phase external signal. Table 1.15.2 lists timer specifications when counting a single-phase external signal. Figure 1.15.8 shows the timer Ai mode register in event counter mode.

Table 1.15.3 lists timer specifications when counting a two-phase external signal. Figure 1.15.9 shows the timer Ai mode register in event counter mode.

Table 1.15.2. Timer specifications in event counter mode (when not processing two-phase pulse signal)

Item	Specification
Count source	<ul style="list-style-type: none"> External signals input to TAIIn pin (effective edge can be selected by software) TB2 overflow, TAJ overflow
Count operation	<ul style="list-style-type: none"> Up count or down count can be selected by external signal or software When the timer overflows or underflows, it reloads the reload register contents before continuing counting (Note)
Divide ratio	$1 / (FFFF_{16} - n + 1)$ for up count $1 / (n + 1)$ for down count n : Set value
Count start condition	Count start flag is set (= 1)
Count stop condition	Count start flag is reset (= 0)
Interrupt request generation timing	The timer overflows or underflows
TAiIn pin function	Programmable I/O port or count source input
TAiOUT pin function	Programmable I/O port, pulse output, or up/down count select input
Read from timer	Count value can be read out by reading timer Ai register
Write to timer	<ul style="list-style-type: none"> When counting stopped When a value is written to timer Ai register, it is written to both reload register and counter When counting in progress When a value is written to timer Ai register, it is written to only reload register (Transferred to counter at next reload time)
Select function	<ul style="list-style-type: none"> Free-run count function Even when the timer overflows or underflows, the reload register content is not reloaded to it Pulse output function Each time the timer overflows or underflows, the TAIOUT pin's polarity is reversed

Note: This does not apply when the free-run function is selected.

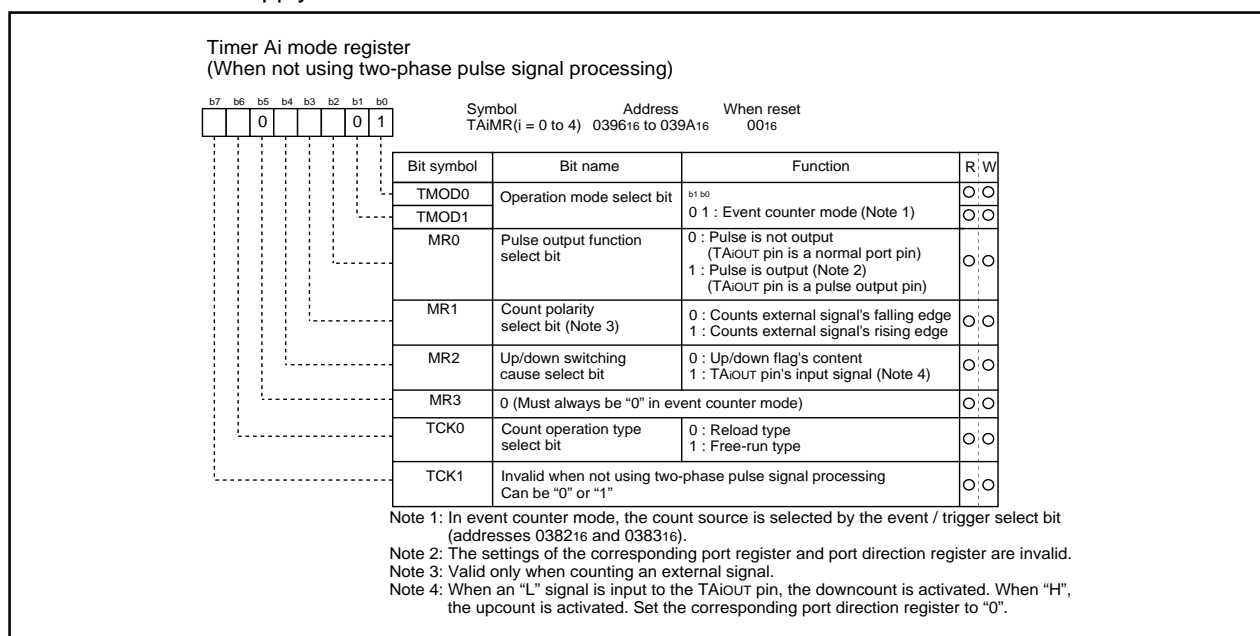
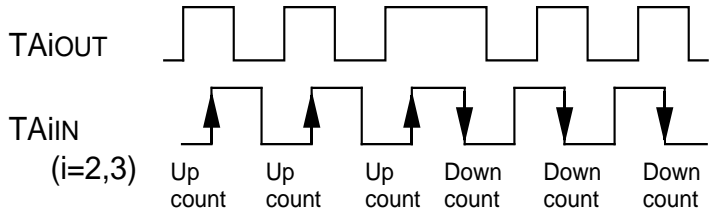
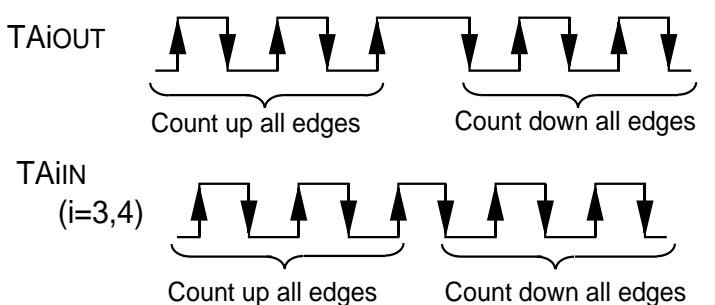

Figure 1.15.8. Timer Ai mode register in event counter mode

Table 1.15.3. Timer specifications in event counter mode (when processing two-phase pulse signal with timers A2, A3, and A4)

Item	Specification
Count source	• Two-phase pulse signals input to TAIiN or TAIoUT pin
Count operation	• Up count or down count can be selected by two-phase pulse signal • When the timer overflows or underflows, the reload register content is reloaded and the timer starts over again (Note 1)
Divide ratio	1/ (FFFF ₁₆ - n + 1) for up count 1/ (n + 1) for down count n : Set value
Count start condition	Count start flag is set (= 1)
Count stop condition	Count start flag is reset (= 0)
Interrupt request generation timing	Timer overflows or underflows
TAiIN pin function	Two-phase pulse input (Set the TAIiN pin correspondent port direction register to "0".)
TAIoUT pin function	Two-phase pulse input (Set the TAIoUT pin correspondent port direction register to "0".)
Read from timer	Count value can be read out by reading timer A2, A3, or A4 register
Write to timer	• When counting stopped When a value is written to timer A2, A3, or A4 register, it is written to both reload register and counter • When counting in progress When a value is written to timer A2, A3, or A4 register, it is written to only reload register. (Transferred to counter at next reload time.)
Select function (Note 2)	• Normal processing operation (timer A2 and timer A3) The timer counts up rising edges or counts down falling edges on the TAIiN pin when input signal on the TAIoUT pin is "H".  • Multiply-by-4 processing operation (timer A3 and timer A4) If the phase relationship is such that the TAIiN pin goes "H" when the input signal on the TAIoUT pin is "H", the timer counts up rising and falling edges on the TAIoUT and TAIiN pins. If the phase relationship is such that the TAIiN pin goes "L" when the input signal on the TAIoUT pin is "H", the timer counts down rising and falling edges on the TAIoUT and TAIiN pins. 

Note 1: This does not apply when the free-run function is selected.

Note 2: Timer A3 alone can be selected. Timer A2 is fixed to normal processing operation, and timer A4 is fixed to multiply-by-4 processing operation.

Timer A

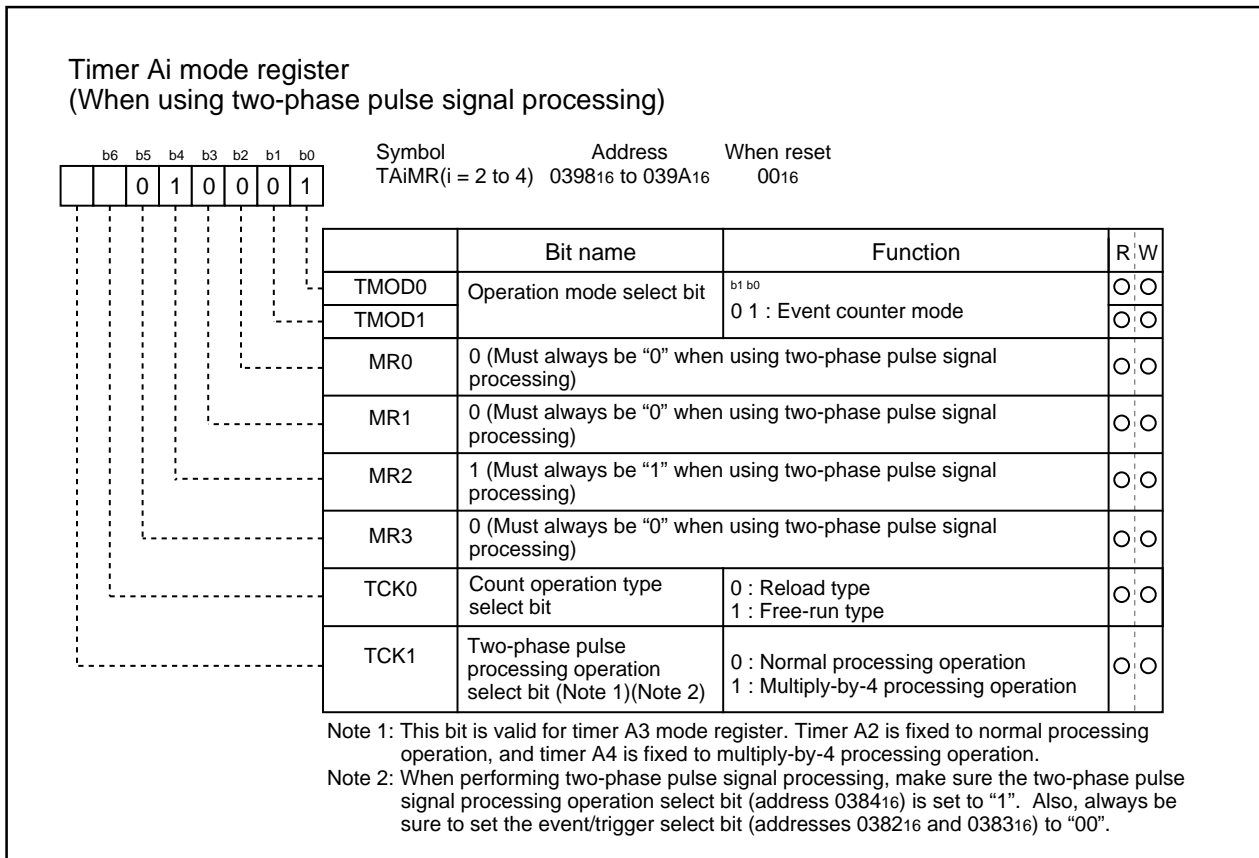

Figure 1.15.9. Timer Ai mode register in event counter mode

(3) One-shot timer mode

In this mode, the timer operates only once. (See Table 1.15.4.) When a trigger occurs, the timer starts up and continues operating for a given period. Figure 1.15.10 shows the timer Ai mode register in one-shot timer mode.

Table 1.15.4. Timer specifications in one-shot timer mode

Item	Specification
Count source	f1, f8, f32, fc32
Count operation	<ul style="list-style-type: none"> The timer counts down When the count reaches 0000₁₆, the timer stops counting after reloading a new count If a trigger occurs when counting, the timer reloads a new count and restarts counting
Divide ratio	1/n n : Set value
Count start condition	<ul style="list-style-type: none"> An external trigger is input The timer overflows The one-shot start flag is set (= 1)
Count stop condition	<ul style="list-style-type: none"> A new count is reloaded after the count has reached 0000₁₆ The count start flag is reset (= 0)
Interrupt request generation timing	The count reaches 0000 ₁₆
TAiIN pin function	Programmable I/O port or trigger input
TAiOUT pin function	Programmable I/O port or pulse output
Read from timer	When timer Ai register is read, it indicates an indeterminate value
Write to timer	<ul style="list-style-type: none"> When counting stopped When a value is written to timer Ai register, it is written to both reload register and counter When counting in progress When a value is written to timer Ai register, it is written to only reload register (Transferred to counter at next reload time)

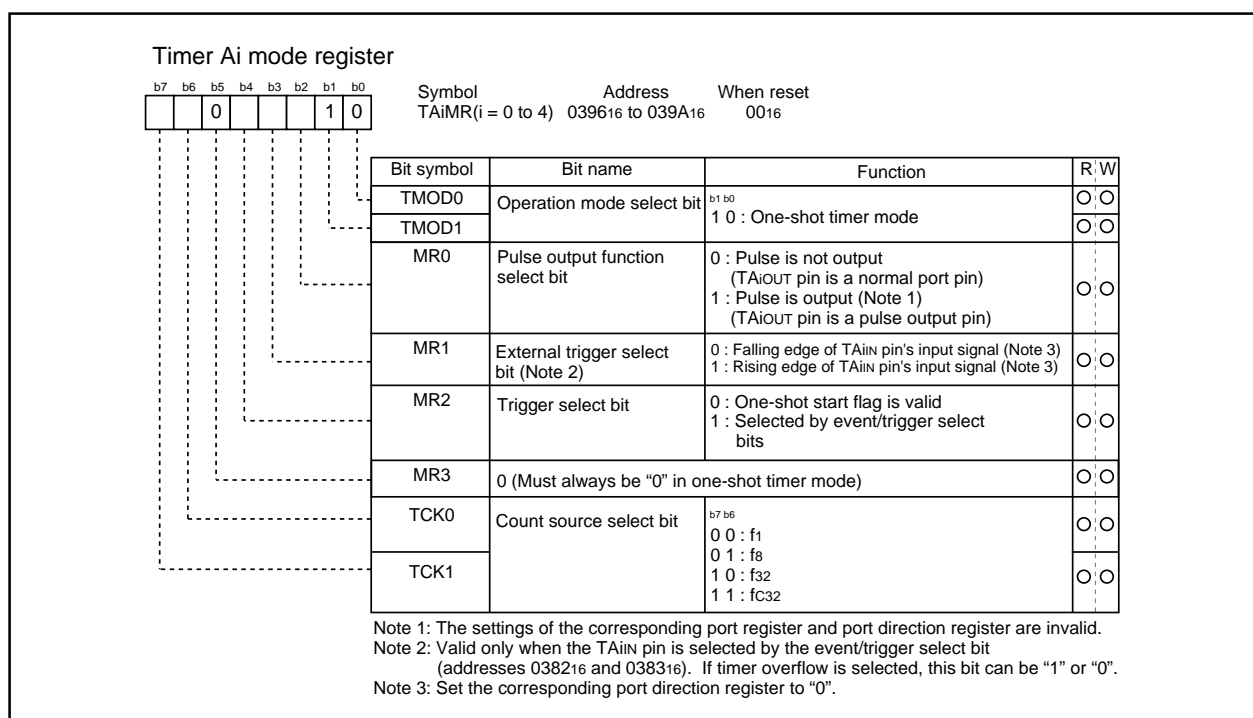

Figure 1.15.10. Timer Ai mode register in one-shot timer mode

(4) Pulse width modulation (PWM) mode

In this mode, the timer outputs pulses of a given width in succession. (See Table 1.15.5.) In this mode, the counter functions as either a 16-bit pulse width modulator or an 8-bit pulse width modulator. Figure 1.15.11 shows the timer Ai mode register in pulse width modulation mode. Figure 1.15.12 shows the example of how a 16-bit pulse width modulator operates. Figure 1.15.13 shows the example of how an 8-bit pulse width modulator operates.

Table 1.15.5. Timer specifications in pulse width modulation mode

Item	Specification
Count source	f1, f8, f32, fc32
Count operation	<ul style="list-style-type: none"> The timer counts down (operating as an 8-bit or a 16-bit pulse width modulator) The timer reloads a new count at a rising edge of PWM pulse and continues counting The timer is not affected by a trigger that occurs when counting
16-bit PWM	<ul style="list-style-type: none"> High level width n / f_i n: Set value Cycle time $(2^{16}-1) / f_i$ fixed
8-bit PWM	<ul style="list-style-type: none"> High level width $n \times (m+1) / f_i$ n: values set to timer Ai register's high-order address Cycle time $(2^8-1) \times (m+1) / f_i$ m: values set to timer Ai register's low-order address
Count start condition	<ul style="list-style-type: none"> External trigger is input The timer overflows The count start flag is set (= 1)
Count stop condition	<ul style="list-style-type: none"> The count start flag is reset (= 0)
Interrupt request generation timing	PWM pulse goes "L"
TAiIN pin function	Programmable I/O port or trigger input
TAiOUT pin function	Pulse output
Read from timer	When timer Ai register is read, it indicates an indeterminate value
Write to timer	<ul style="list-style-type: none"> When counting stopped When a value is written to timer Ai register, it is written to both reload register and counter When counting in progress When a value is written to timer Ai register, it is written to only reload register (Transferred to counter at next reload time)

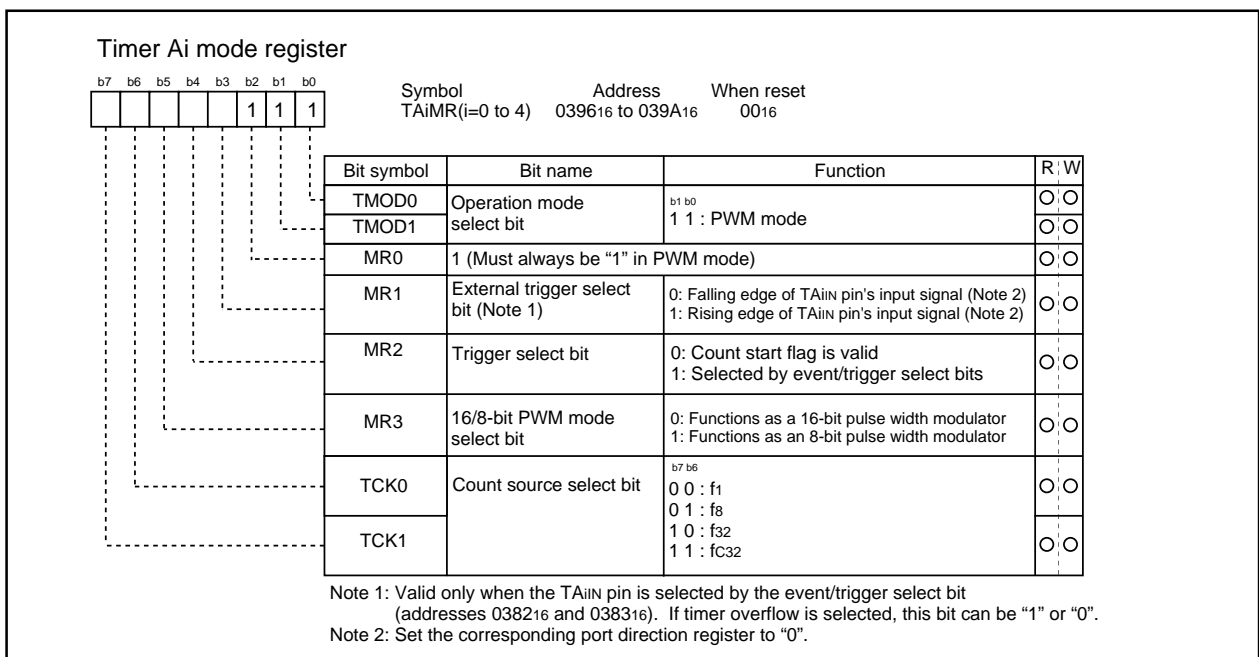

Figure 1.15.11. Timer Ai mode register in pulse width modulation mode

Timer A

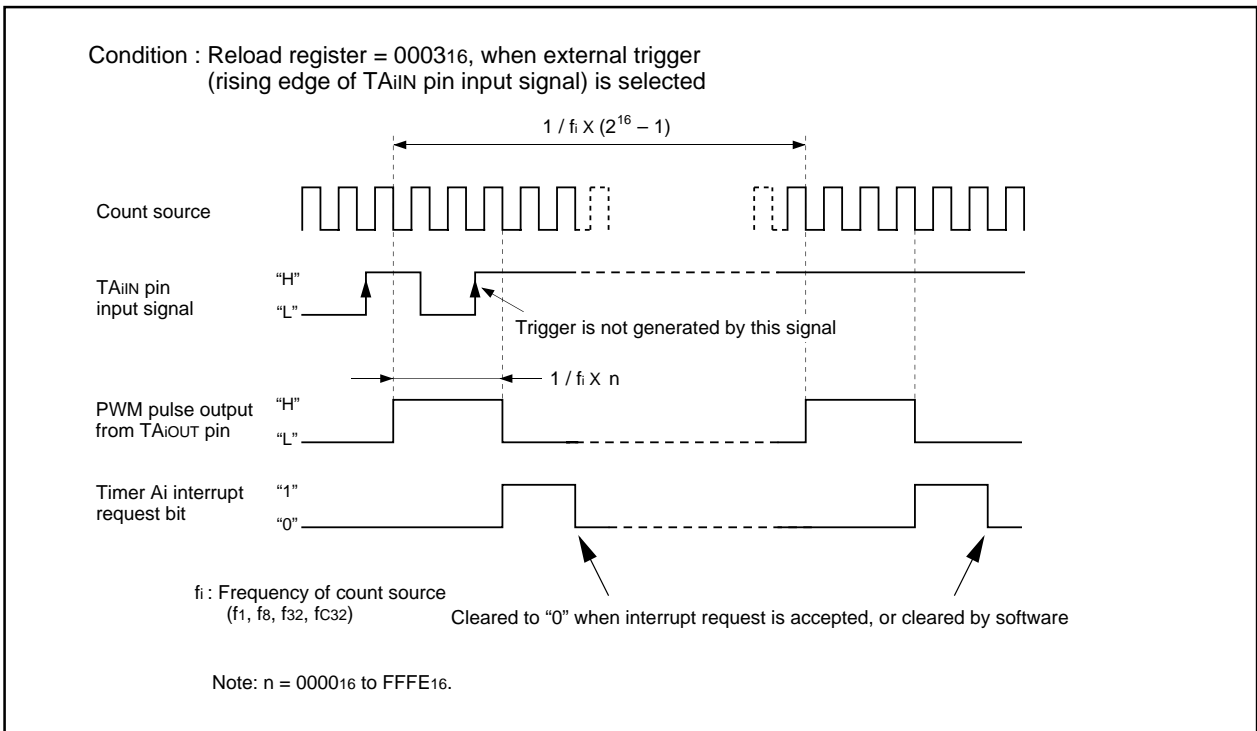

Figure 1.15.12. Example of how a 16-bit pulse width modulator operates

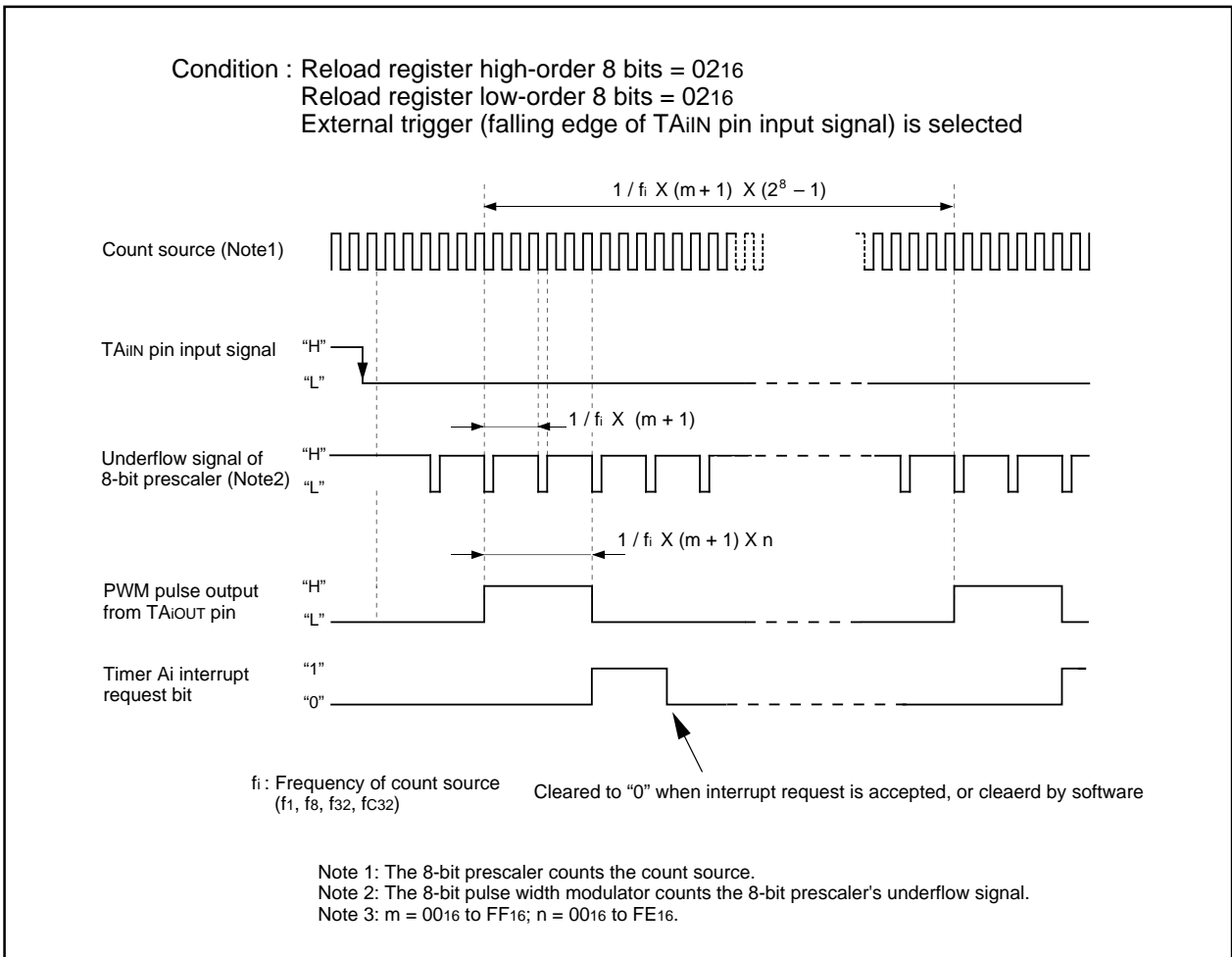

Figure 1.15.13. Example of how an 8-bit pulse width modulator operates

Timer B

Timer B

Figure 1.15.14 shows the block diagram of timer B. Figures 1.15.15 and 1.15.16 show the timer B-related registers.

Use the timer Bi mode register (i = 0 to 5) bits 0 and 1 to choose the desired mode.

Timer B has three operation modes listed as follows:

- Timer mode: The timer counts an internal count source.
- Event counter mode: The timer counts pulses from an external source or a timer overflow.
- Pulse period/pulse width measuring mode: The timer measures an external signal's pulse period or pulse width.

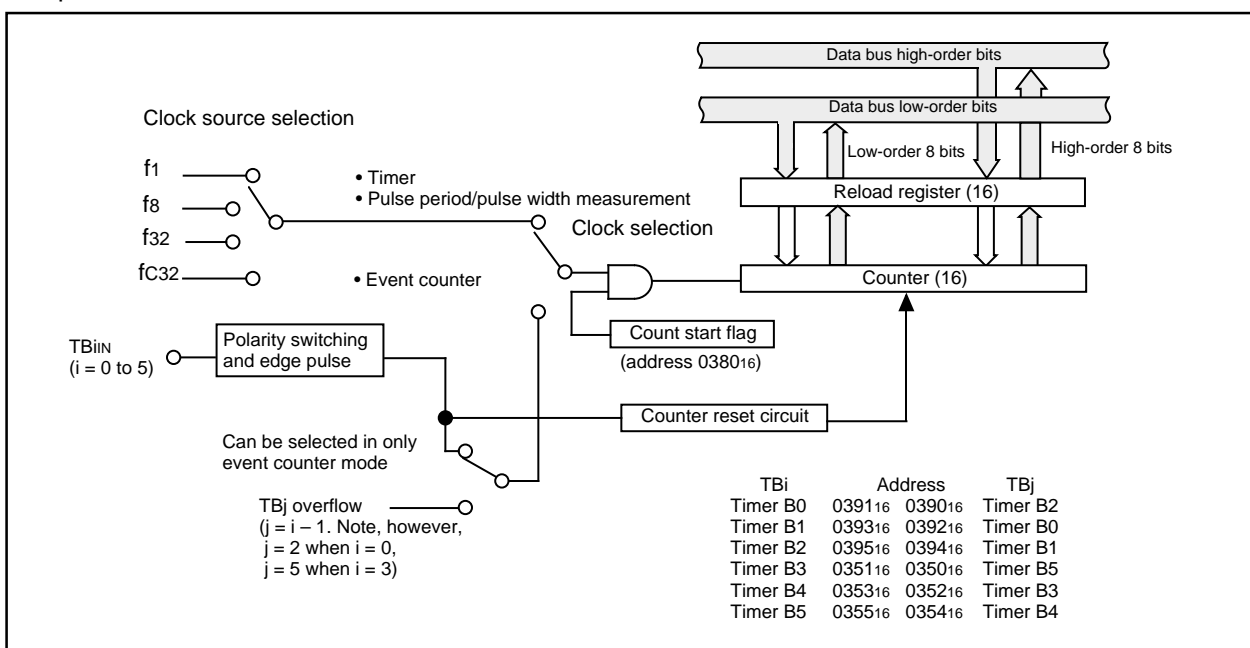

Figure 1.15.14. Block diagram of timer B

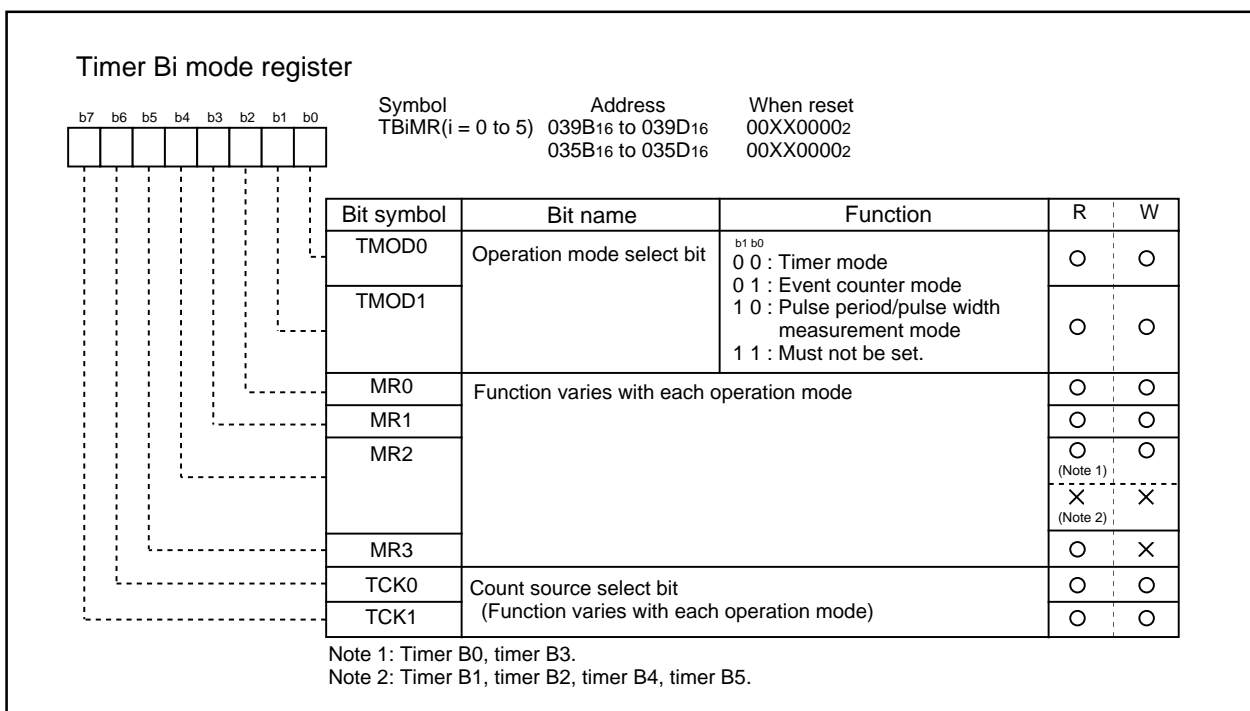

Figure 1.15.15. Timer B-related registers (1)

Timer B

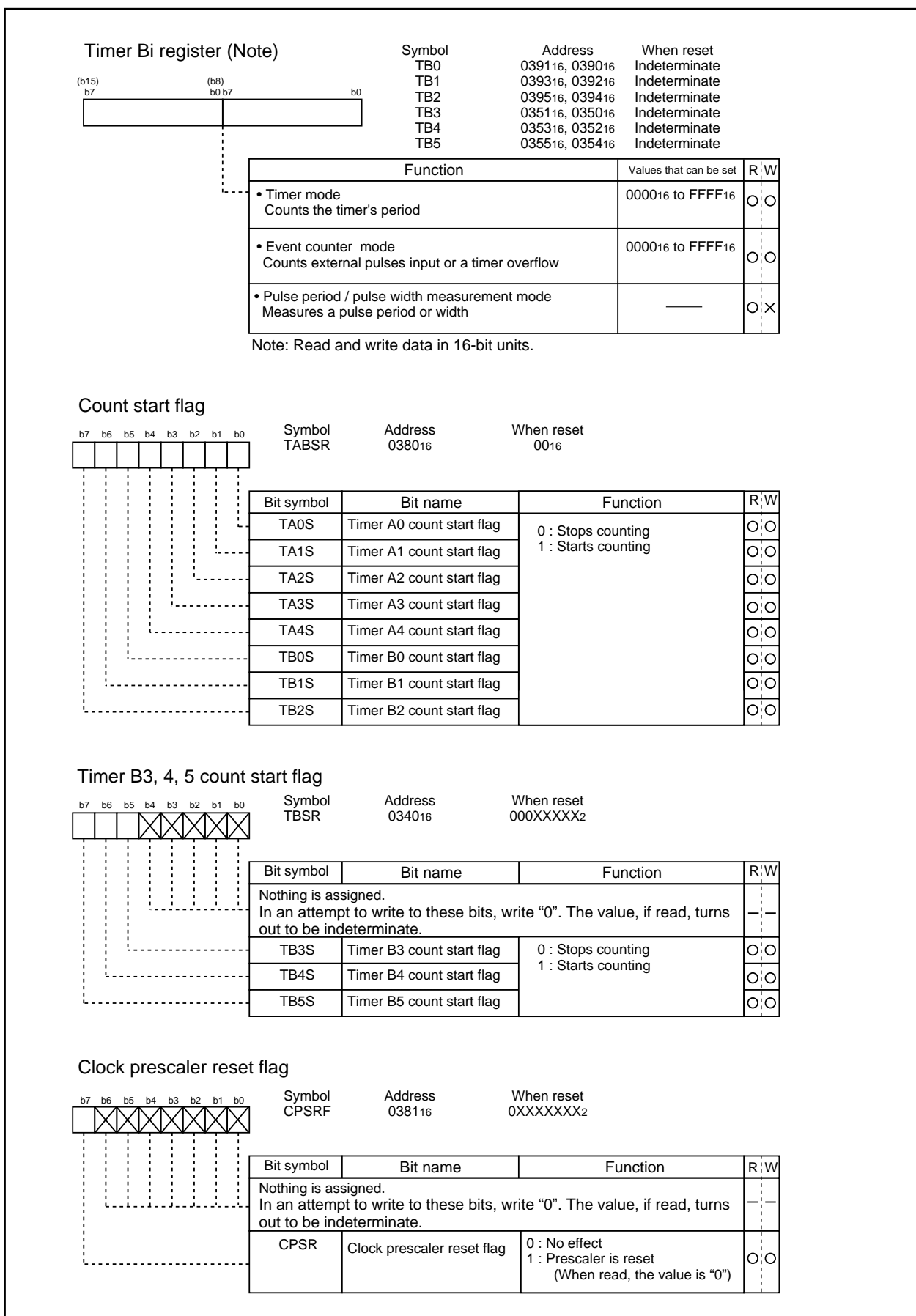

Figure 1.15.16. Timer B-related registers (2)

Timer B

(1) Timer mode

In this mode, the timer counts an internally generated count source. (See Table 1.15.6.) Figure 1.15.17 shows the timer Bi mode register in timer mode.

Table 1.15.6. Timer specifications in timer mode

Item	Specification
Count source	f1, f8, f32, fC32
Count operation	<ul style="list-style-type: none"> Counts down When the timer underflows, it reloads the reload register contents before continuing counting
Divide ratio	1/(n+1) n : Set value
Count start condition	Count start flag is set (= 1)
Count stop condition	Count start flag is reset (= 0)
Interrupt request generation timing	The timer underflows
TBiIN pin function	Programmable I/O port
Read from timer	Count value is read out by reading timer Bi register
Write to timer	<ul style="list-style-type: none"> When counting stopped When a value is written to timer Bi register, it is written to both reload register and counter When counting in progress When a value is written to timer Bi register, it is written to only reload register (Transferred to counter at next reload time)

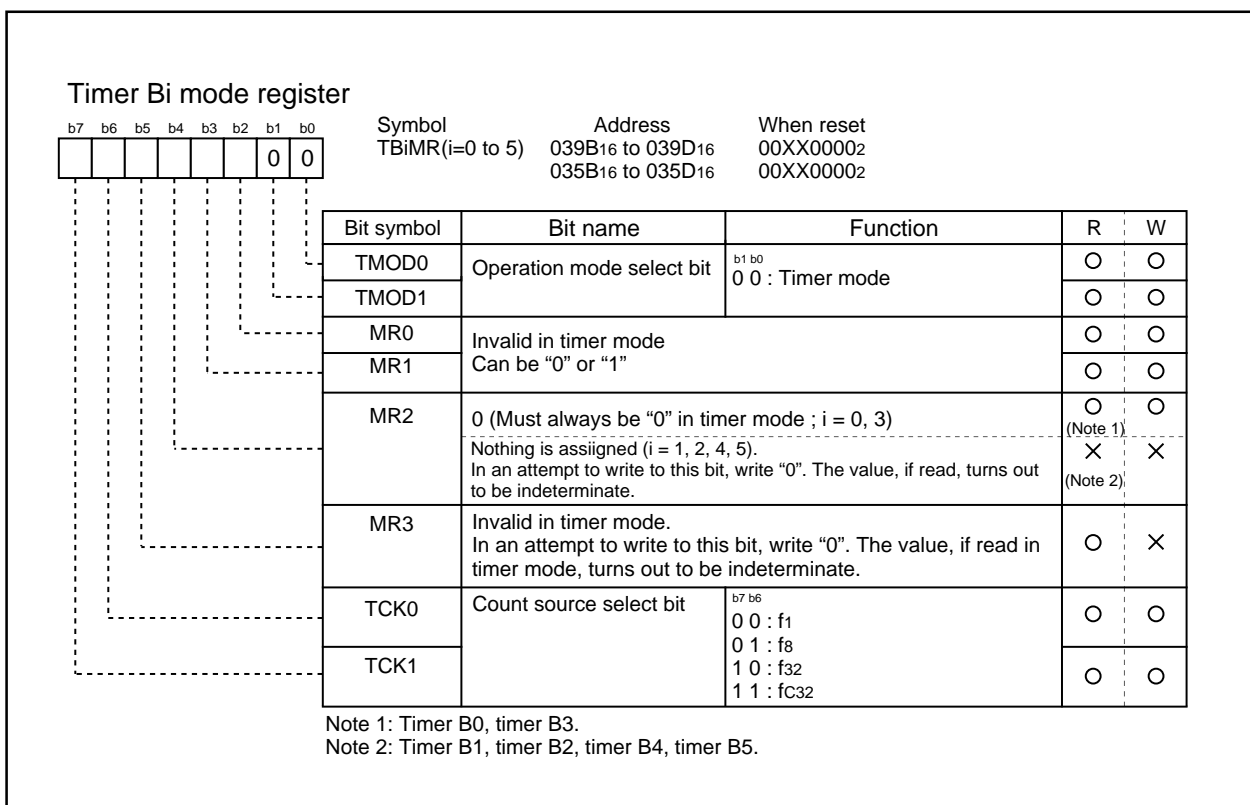
**Figure 1.15.17. Timer Bi mode register in timer mode**

(2) Event counter mode

In this mode, the timer counts an external signal or an internal timer's overflow. (See Table 1.15.7.)
 Figure 1.15.18 shows the timer Bi mode register in event counter mode.

Table 1.15.7. Timer specifications in event counter mode

Item	Specification
Count source	<ul style="list-style-type: none"> External signals input to TBiIn pin Effective edge of count source can be a rising edge, a falling edge, or falling and rising edges as selected by software
Count operation	<ul style="list-style-type: none"> Counts down When the timer underflows, it reloads the reload register contents before continuing counting
Divide ratio	1/(n+1) n : Set value
Count start condition	Count start flag is set (= 1)
Count stop condition	Count start flag is reset (= 0)
Interrupt request generation timing	The timer underflows
TBiIn pin function	Count source input
Read from timer	Count value can be read out by reading timer Bi register
Write to timer	<ul style="list-style-type: none"> When counting stopped When a value is written to timer Bi register, it is written to both reload register and counter When counting in progress When a value is written to timer Bi register, it is written to only reload register (Transferred to counter at next reload time)

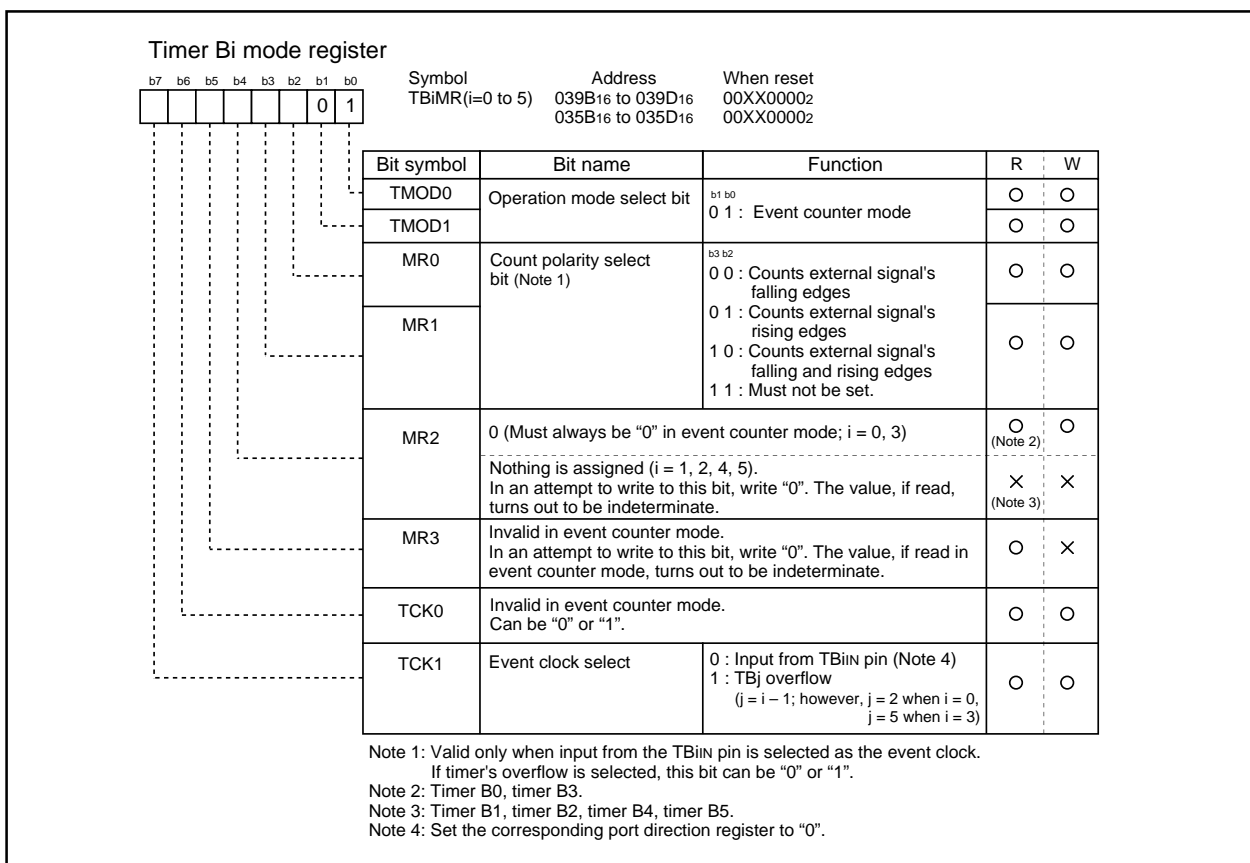

Figure 1.15.18. Timer Bi mode register in event counter mode

(3) Pulse period/pulse width measurement mode

In this mode, the timer measures the pulse period or pulse width of an external signal. (See Table 1.15.8.)

Figure 1.15.19 shows the timer Bi mode register in pulse period/pulse width measurement mode. Figure

1.15.20 shows the operation timing when measuring a pulse period. Figure 1.15.21 shows the operation

timing when measuring a pulse width.

Table 1.15.8. Timer specifications in pulse period/pulse width measurement mode

Item	Specification
Count source	f1, f8, f32, fc32
Count operation	<ul style="list-style-type: none"> • Up count • Counter value "000016" is transferred to reload register at measurement pulse's effective edge and the timer continues counting
Count start condition	Count start flag is set (= 1)
Count stop condition	Count start flag is reset (= 0)
Interrupt request generation timing	<ul style="list-style-type: none"> • When measurement pulse's effective edge is input (Note 1) • When an overflow occurs. (Simultaneously, the timer Bi overflow flag changes to "1". Assume that the count start flag condition is "1" and then the timer Bi overflow flag becomes "1". If the timer Bi mode register has a write access after next count cycle of the timer from the above condition, the timer Bi overflow flag becomes "0".)
TBiIN pin function	Measurement pulse input
Read from timer	When timer Bi register is read, it indicates the reload register's content (measurement result) (Note 2)
Write to timer	Cannot be written to

Note 1: An interrupt request is not generated when the first effective edge is input after the timer has started counting.

Note 2: The value read out from the timer Bi register is indeterminate until the second effective edge is input after the timer has started counting.

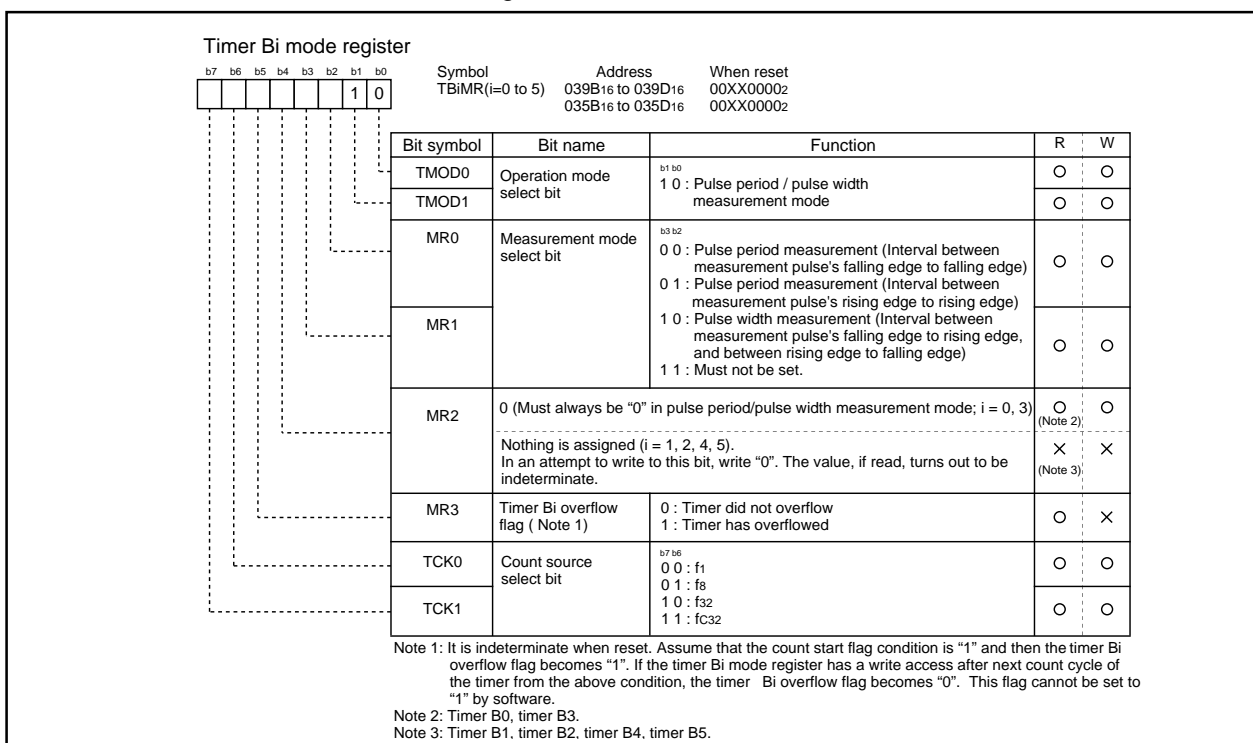

Figure 1.15.19. Timer Bi mode register in pulse period/pulse width measurement mode

Timer B

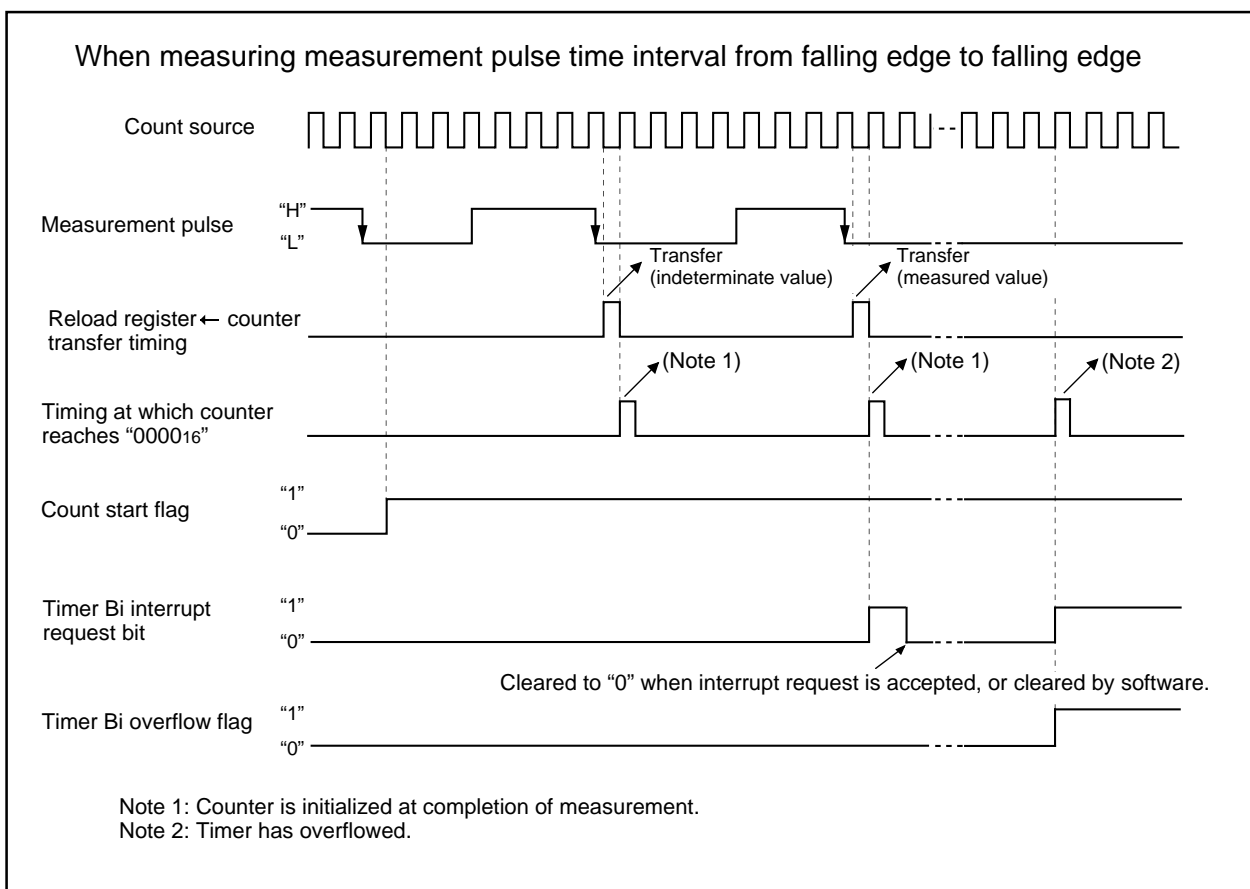

Figure 1.15.20. Operation timing when measuring a pulse period

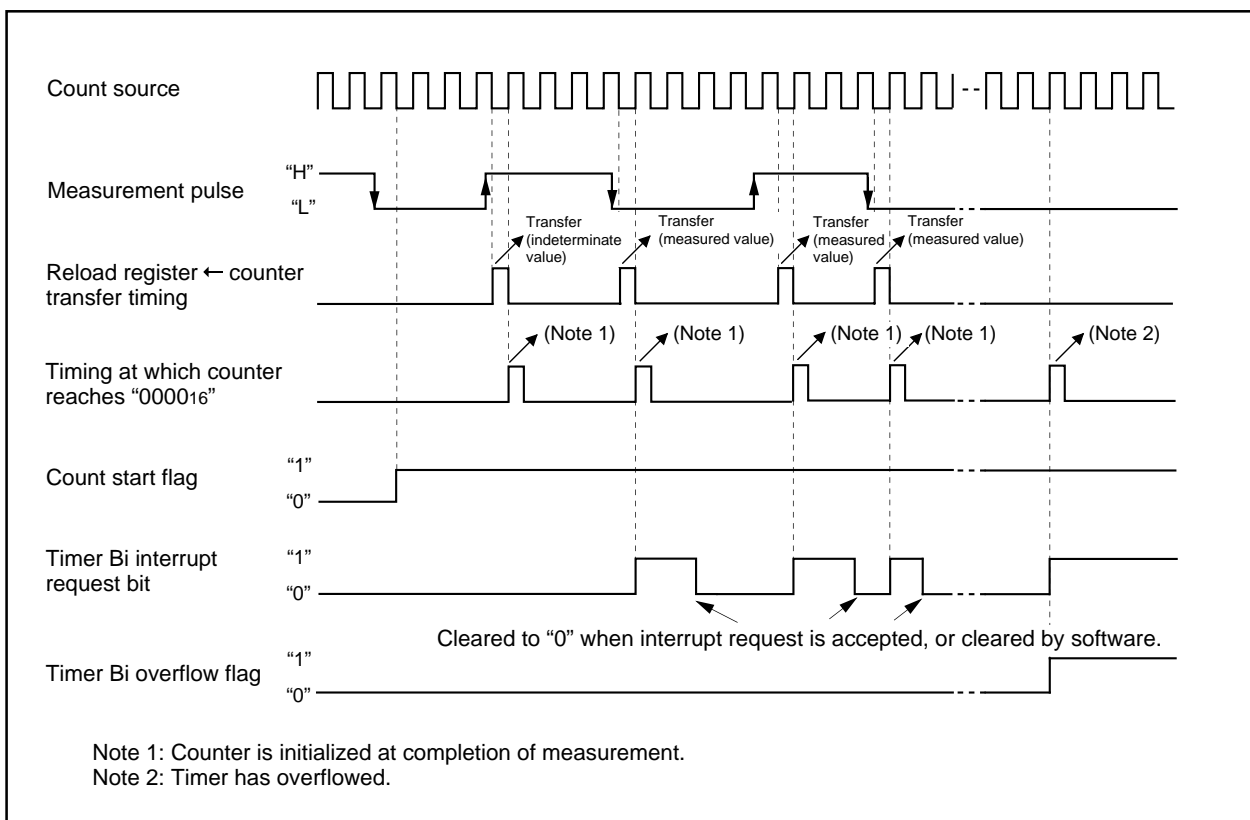

Figure 1.15.21. Operation timing when measuring a pulse width

Timers' functions for three-phase motor control

Use of more than one built-in timer A and timer B provides the means of outputting three-phase motor driving waveforms.

Figures 1.16.1 to 1.16.3 show registers related to timers for three-phase motor control.

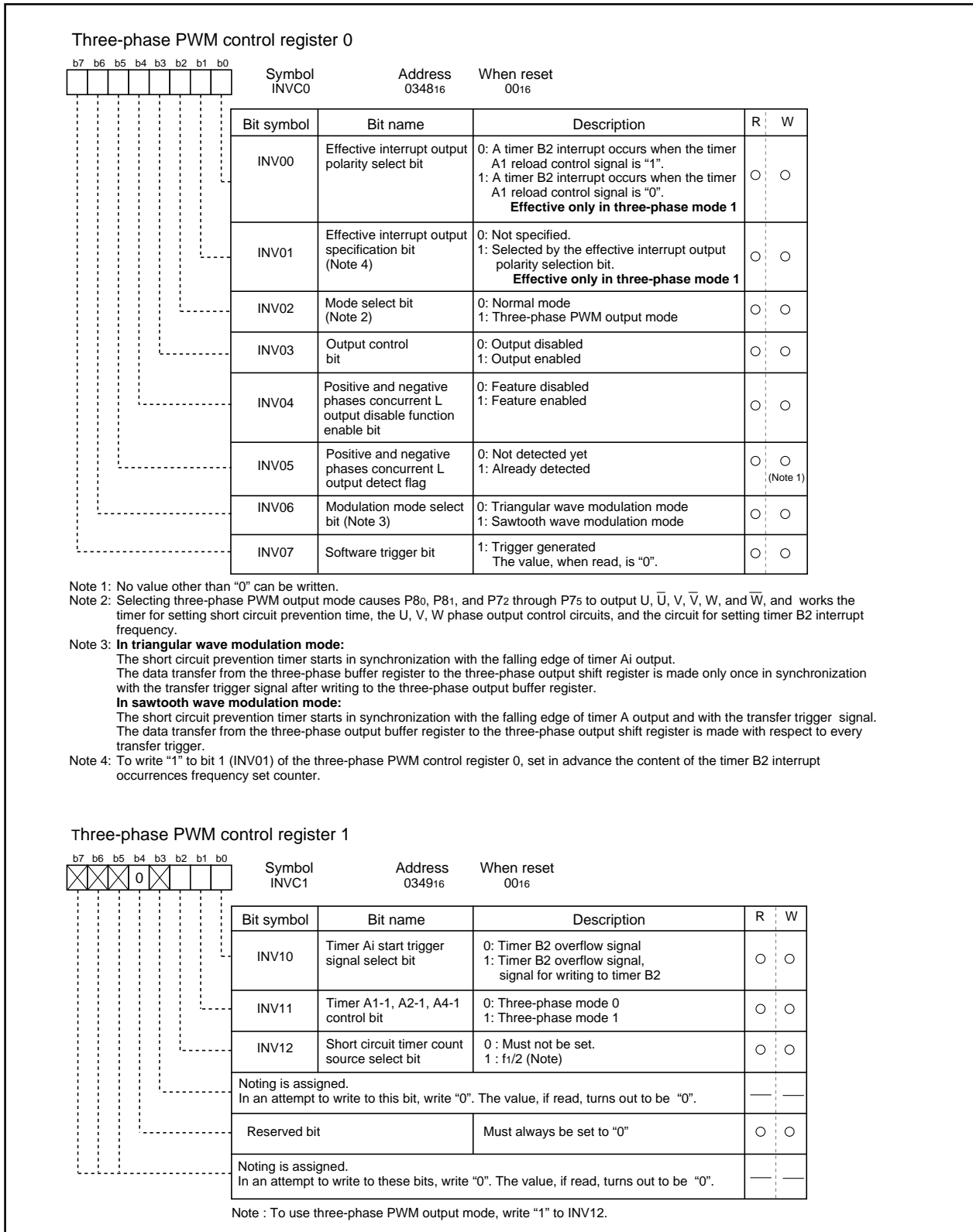
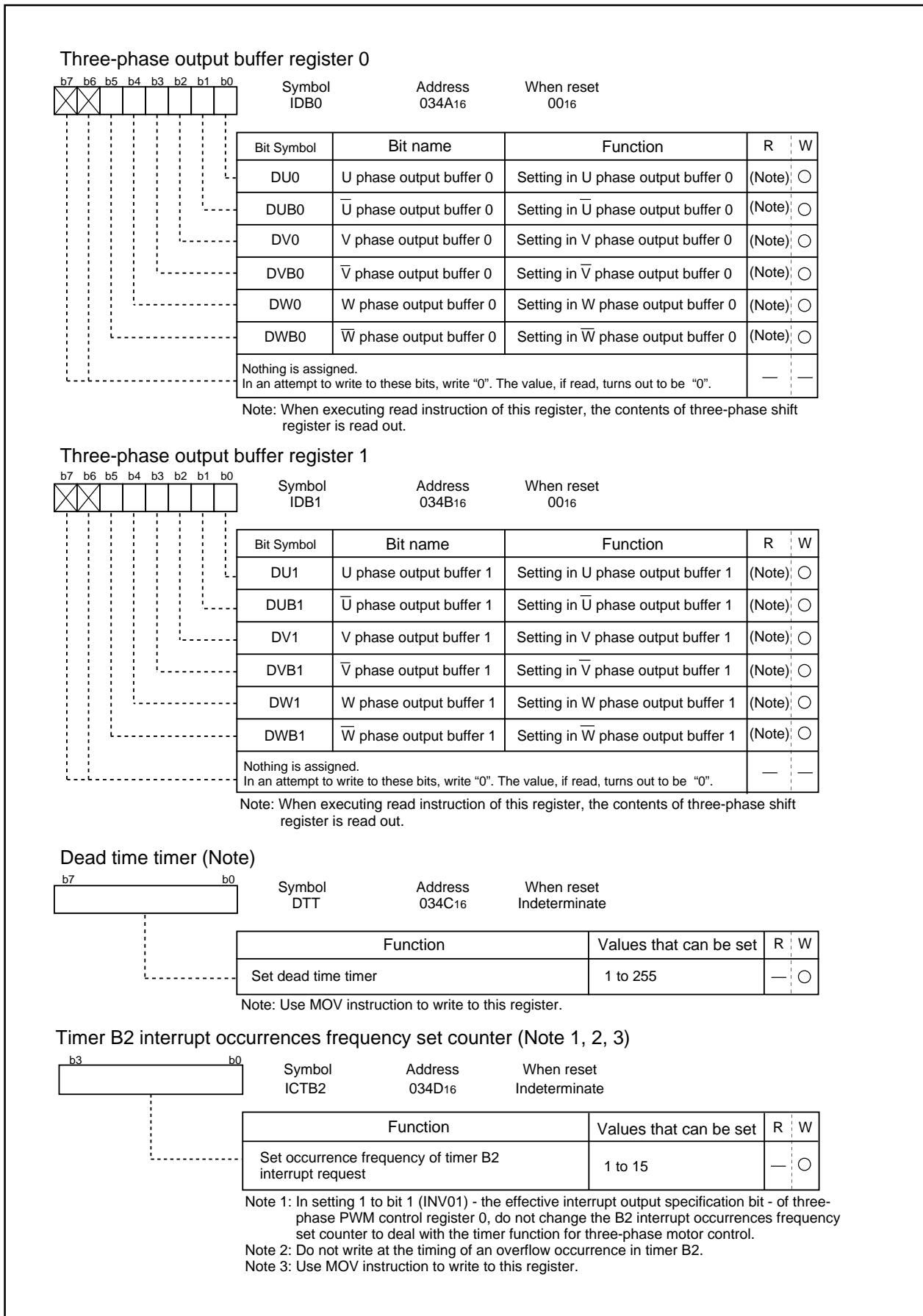

Figure 1.16.1. Registers related to timers for three-phase motor control

Timers' functions for three-phase motor control



Timers' functions for three-phase motor control

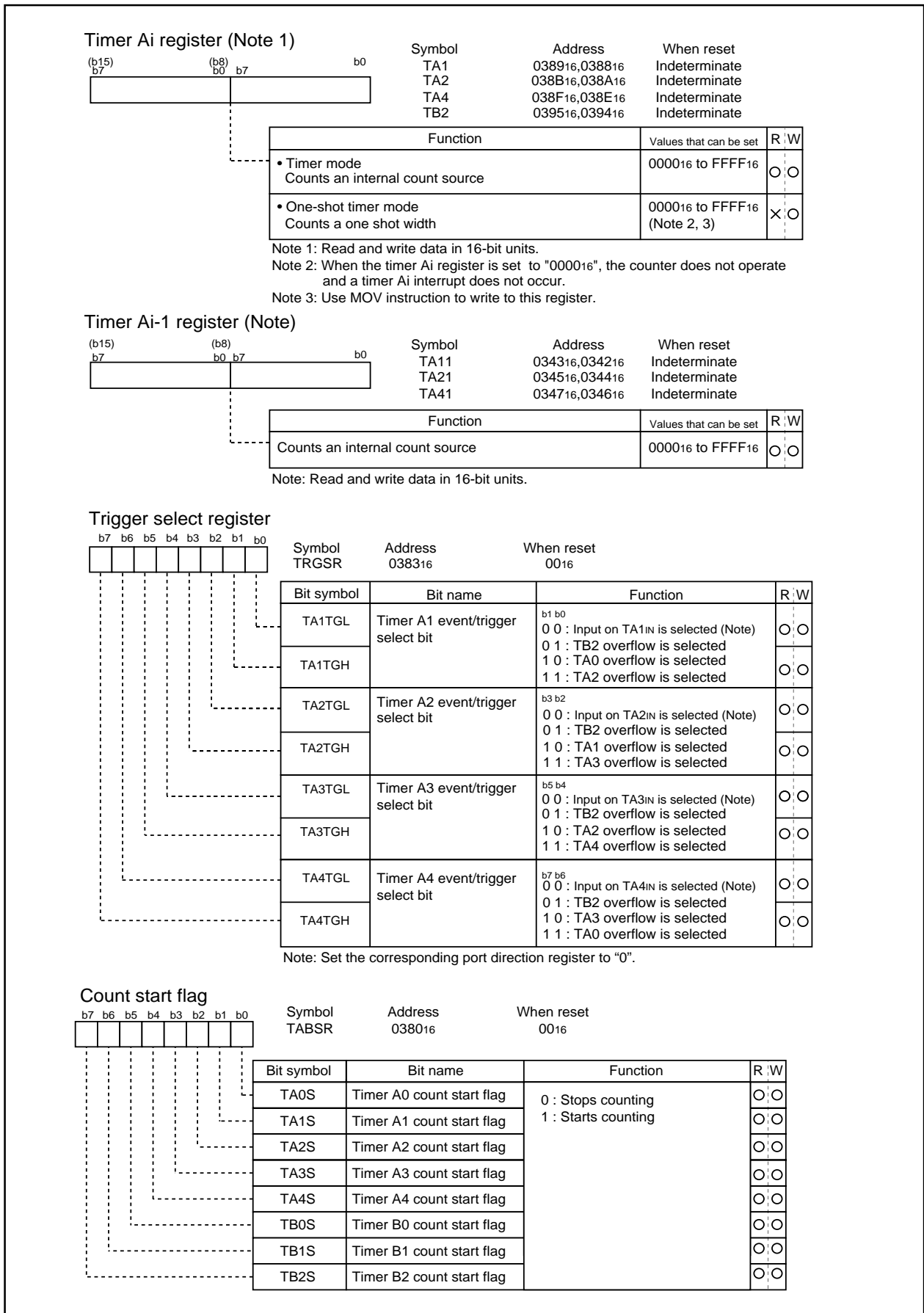

Figure 1.16.3. Registers related to timers for three-phase motor control

Three-phase motor driving waveform output mode (three-phase PWM output mode)

Setting "1" in the mode select bit (bit 2 at 034816) shown in Figure 1.16.1 - causes three-phase PWM output mode that uses four timers A1, A2, A4, and B2 to be selected. As shown in Figure 1.16.4, set timers A1, A2, and A4 in one-shot timer mode, set the trigger in timer B2, and set timer B2 in timer mode using the respective timer mode registers.

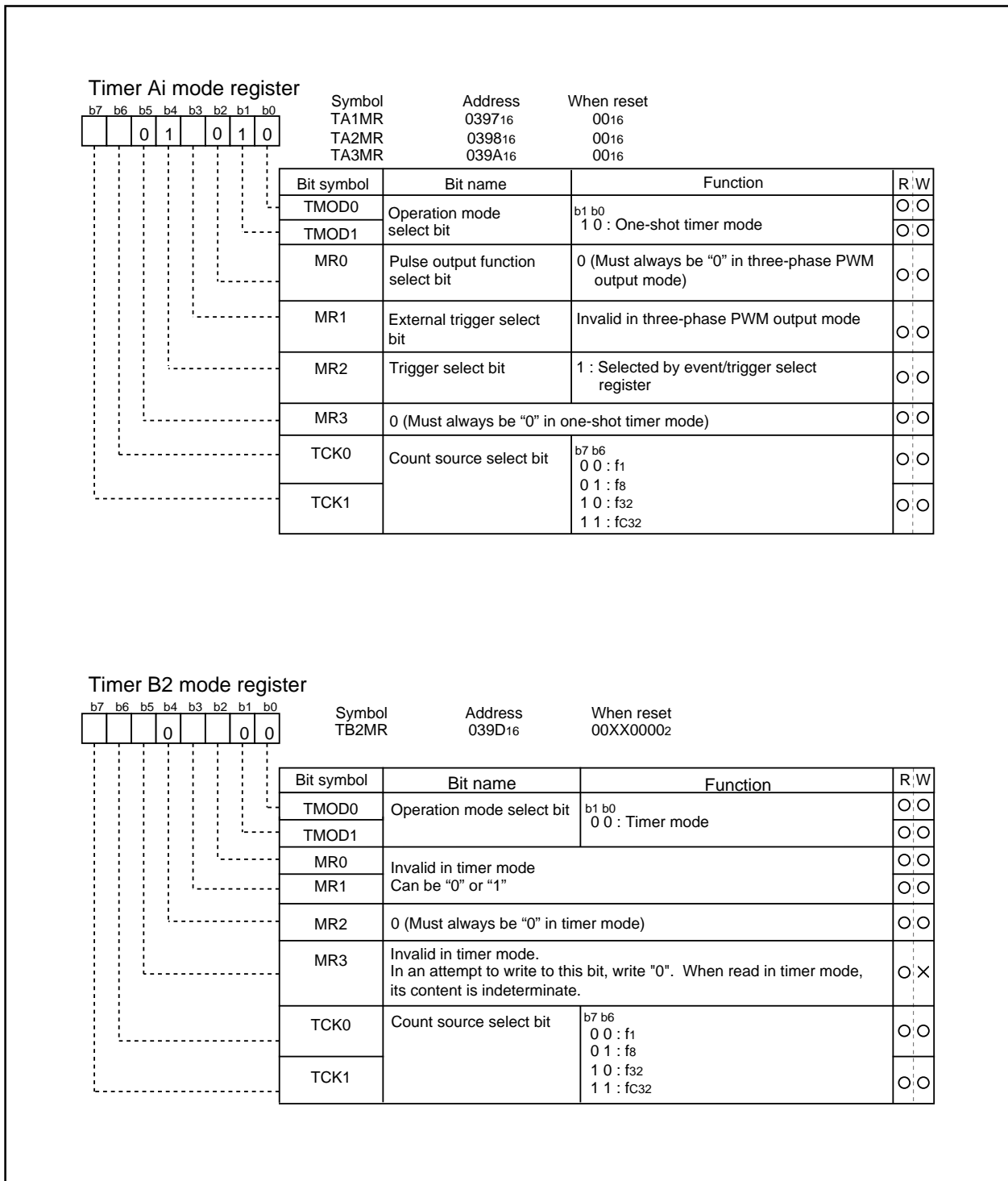

Figure 1.16.4. Timer mode registers in three-phase PWM output mode

Figure 1.16.5 shows the block diagram for three-phase PWM output mode. In three-phase PWM output mode, the positive-phase waveforms (U phase, V phase, and W phase) and negative waveforms (\bar{U} phase, \bar{V} phase, and \bar{W} phase), six waveforms in total, are output from P80, P81, P72, P73, P74, and P75 as active on the "L" level. Of the timers used in this mode, timer A4 controls the U phase and \bar{U} phase, timer A1 controls the V phase and \bar{V} phase, and timer A2 controls the W phase and \bar{W} phase respectively; timer B2 controls the periods of one-shot pulse output from timers A4, A1, and A2.

In outputting a waveform, dead time can be set so as to cause the "L" level of the positive waveform output (U phase, V phase, and W phase) not to lap over the "L" level of the negative waveform output (\bar{U} phase, \bar{V} phase, and \bar{W} phase).

To set short circuit time, use three 8-bit timers sharing the reload register for setting dead time. A value from 1 through 255 can be set as the count of the timer for setting dead time. The timer for setting dead time works as a one-shot timer. If a value is written to the dead time timer (034C₁₆), the value is written to the reload register shared by the three timers for setting dead time.

Any of the timers for setting dead time takes the value of the reload register into its counter, if a start trigger comes from its corresponding timer, and performs a down count in line with the clock source selected by the dead time timer count source select bit (bit 2 at 0349₁₆). The timer can receive another trigger again before the workings due to the previous trigger are completed. In this instance, the timer performs a down count from the reload register's content after its transfer, provoked by the trigger, to the timer for setting dead time.

Since the timer for setting dead time works as a one-shot timer, it starts outputting pulses if a trigger comes; it stops outputting pulses as soon as its content becomes 00₁₆, and waits for the next trigger to come.

The positive waveforms (U phase, V phase, and W phase) and the negative waveforms (\bar{U} phase, \bar{V} phase, and \bar{W} phase) in three-phase PWM output mode are output from respective ports by means of setting "1" in the output control bit (bit 3 at 0348₁₆). Setting "0" in this bit causes the ports to be the state of set by port direction register. This bit can be set to "0" not only by use of the applicable instruction, but by entering a falling edge in the $\overline{\text{NMI}}$ terminal or by resetting. Also, if "1" is set in the positive and negative phases concurrent L output disable function enable bit (bit 4 at 0348₁₆) causes one of the pairs of U phase and \bar{U} phase, V phase and \bar{V} phase, and W phase and \bar{W} phase concurrently go to "L", as a result, the port becomes the state of set by port direction register.

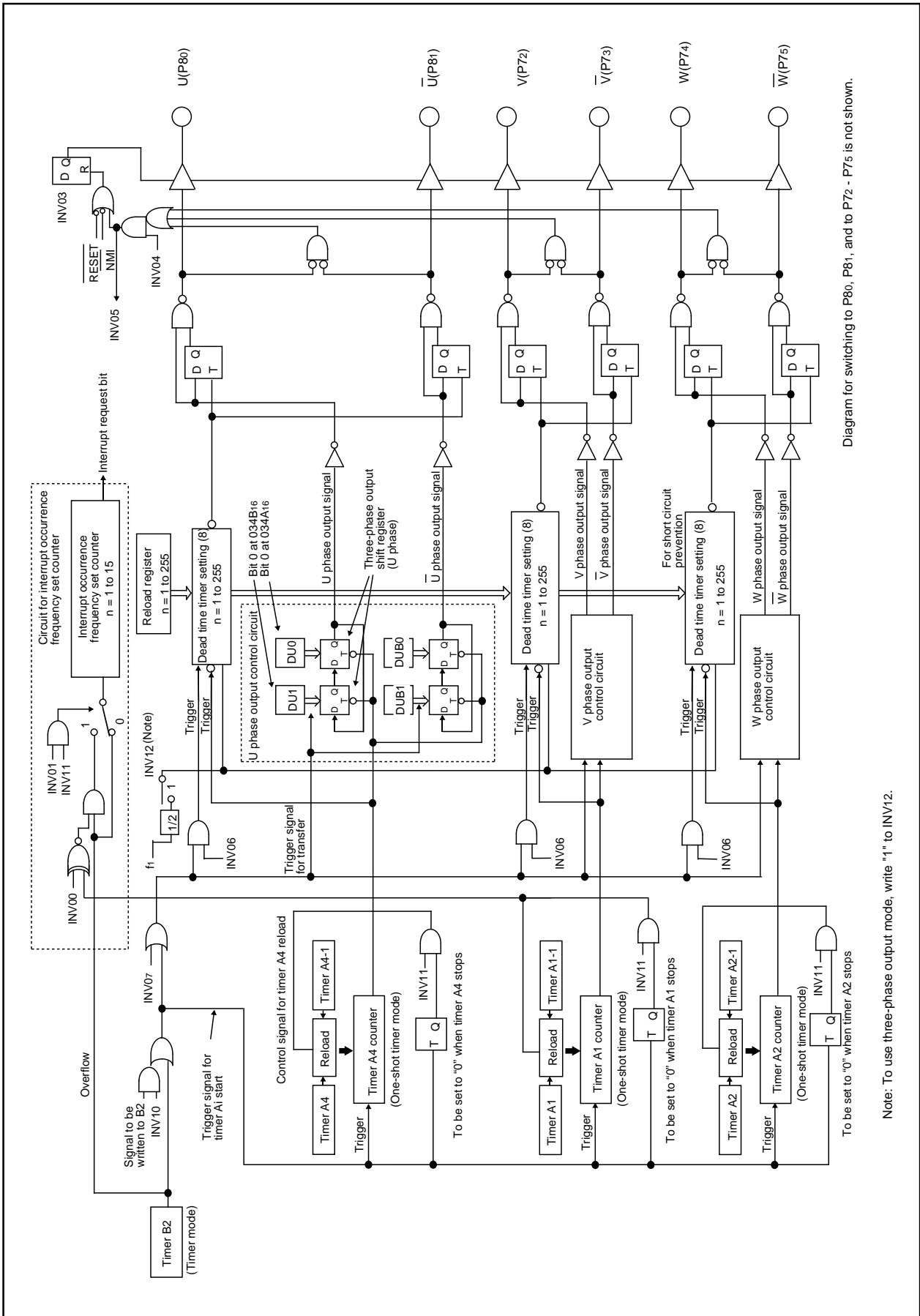

Diagram for switching to P80, P81, and to P72 - P75 is not shown.

Note: To use three-phase output mode, write "1" to INV12.

Figure 1.16.5. Block diagram for three-phase PWM output mode

Triangular wave modulation

To generate a PWM waveform of triangular wave modulation, set "0" in the modulation mode select bit (bit 6 at 0348₁₆). Also, set "1" in the timers A4-1, A1-1, A2-1 control bit (bit 1 at 0349₁₆). In this mode, each of timers A4, A1, and A2 has two timer registers, and alternately reloads the timer register's content to the counter every time timer B2 counter's content becomes 0000₁₆. If "0" is set to the effective interrupt output specification bit (bit 1 at 0348₁₆), the frequency of interrupt requests that occur every time the timer B2 counter's value becomes 0000₁₆ can be set by use of the timer B2 counter (034D₁₆) for setting the frequency of interrupt occurrences. The frequency of occurrences is given by (setting; setting \neq 0).

Setting "1" in the effective interrupt output specification bit (bit 1 at 0348₁₆) provides the means to choose which value of the timer A1 reload control signal to use, "0" or "1", to cause timer B2's interrupt request to occur. To make this selection, use the effective interrupt output polarity selection bit (bit 0 at 0348₁₆).

An example of U phase waveform is shown in Figure 1.16.6, and the description of waveform output workings is given below. Set "1" in DU0 (bit 0 at 034A₁₆). And set "0" in DUB0 (bit 1 at 034A₁₆). In addition, set "0" in DU1 (bit 0 at 034B₁₆) and set "1" in DUB1 (bit 1 at 034B₁₆). Also, set "0" in the effective interrupt output specification bit (bit 1 at 0348₁₆) to set a value in the timer B2 interrupt occurrence frequency set counter. By this setting, a timer B2 interrupt occurs when the timer B2 counter's content becomes 0000₁₆ as many as (setting) times. Furthermore, set "1" in the effective interrupt output specification bit (bit 1 at 0348₁₆), set "0" in the effective interrupt output polarity select bit (bit 0 at 0348₁₆) and set "1" in the interrupt occurrence frequency set counter (034D₁₆). These settings cause a timer B2 interrupt to occur every other interval when the U phase output goes to "H".

When the timer B2 counter's content becomes 0000₁₆, timer A4 starts outputting one-shot pulses. In this instance, the content of DU1 (bit 0 at 034B₁₆) and that of DU0 (bit 0 at 034A₁₆) are set in the three-phase output shift register (U phase), the content of DUB1 (bit 1 at 034B₁₆) and that of DUB0 (bit 1 at 034A₁₆) are set in the three-phase output shift register (\bar{U} phase). After triangular wave modulation mode is selected, however, no setting is made in the shift register even though the timer B2 counter's content becomes 0000₁₆.

The value of DU0 and that of DUB0 are output to the U terminal (P80) and to the \bar{U} terminal (P81) respectively. When the timer A4 counter counts the value written to timer A4 (038F₁₆, 038E₁₆) and when timer A4 finishes outputting one-shot pulses, the three-phase shift register's content is shifted one position, and the value of DU1 and that of DUB1 are output to the U phase output signal and to \bar{U} phase output signal respectively. At this time, one-shot pulses are output from the timer for setting dead time used for setting the time over which the "L" level of the U phase waveform does not lap over the "L" level of the \bar{U} phase waveform, which has the opposite phase of the former. The U phase waveform output that started from the "H" level keeps its level until the timer for setting dead time finishes outputting one-shot pulses even though the three-phase output shift register's content changes from "1" to "0" by the effect of the one-shot pulses. When the timer for setting dead time finishes outputting one-shot pulses, "0" already shifted in the three-phase shift register goes effective, and the U phase waveform changes to the "L" level. When the timer B2 counter's content becomes 0000₁₆, the timer A4 counter starts counting the value written to timer A4-1 (0347₁₆, 0346₁₆), and starts outputting one-shot pulses. When timer A4 finishes outputting one-shot pulses, the three-phase shift register's content is shifted one position, but if the three-phase output shift register's content changes from "0" to "1" as a result of the shift, the output level changes from "L" to "H" without waiting for the timer for setting dead time to finish outputting one-shot pulses. A U phase waveform is generated by these workings repeatedly. With the exception that the three-phase output shift register on the \bar{U} phase side is used, the workings in generating a \bar{U} phase waveform, which has the opposite phase of the U phase waveform, are the same as in generating a U

phase waveform. In this way, a waveform can be picked up from the applicable terminal in a manner in which the "L" level of the U phase waveform doesn't lap over that of the \bar{U} phase waveform, which has the opposite phase of the U phase waveform. The width of the "L" level too can be adjusted by varying the values of timer B2, timer A4, and timer A4-1. In dealing with the V and W phases, and \bar{V} and \bar{W} phases, the latter are of opposite phase of the former, have the corresponding timers work similarly to dealing with the U and \bar{U} phases to generate an intended waveform.

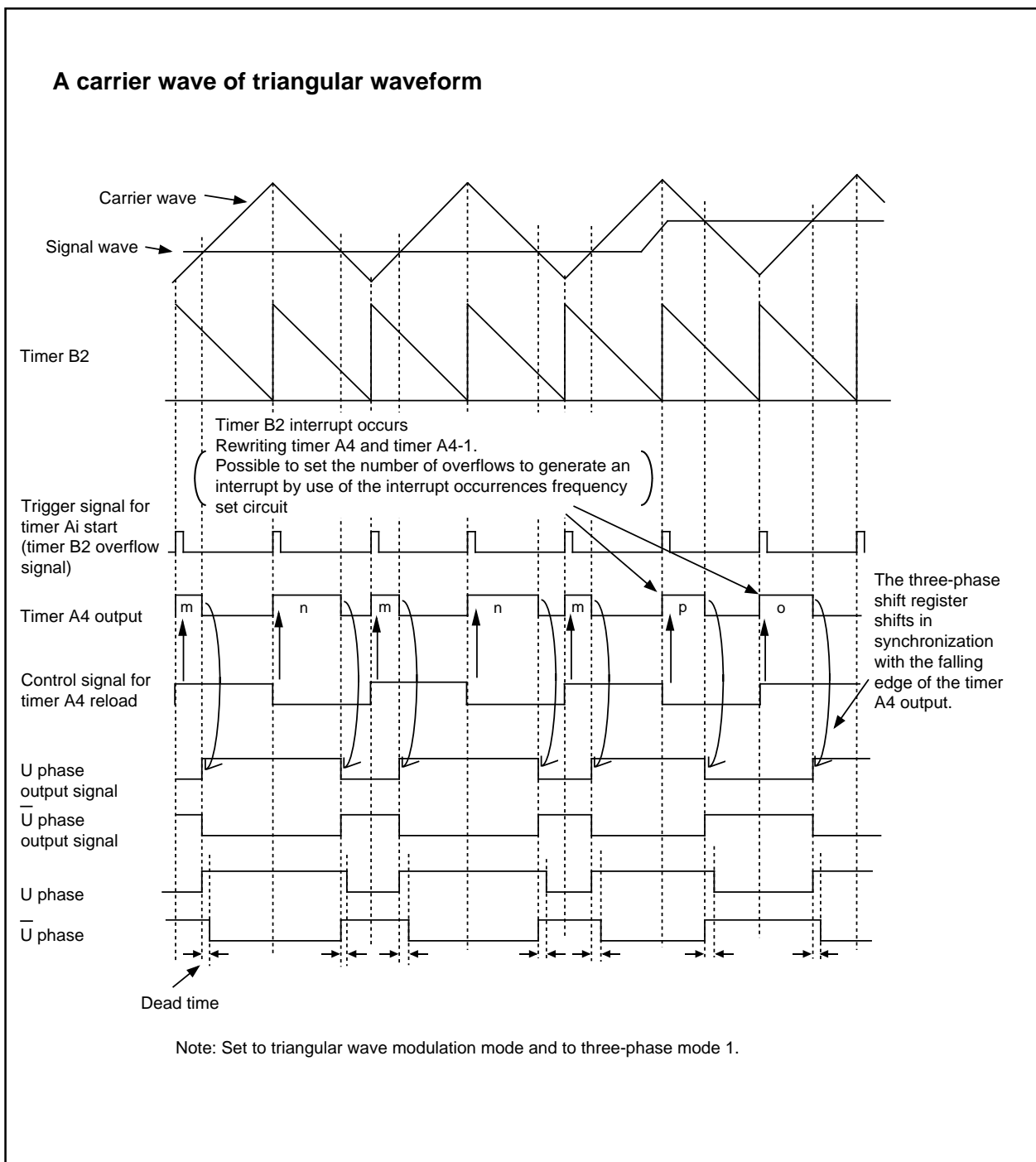

Figure 1.16.6. Timing chart of operation (1)

Timers' functions for three-phase motor control

Assigning certain values to DU0 (bit 0 at 034A16) and DUB0 (bit 1 at 034A16), and to DU1 (bit 0 at 034B16) and DUB1 (bit 1 at 034B16) allows the user to output the waveforms as shown in Figure 1.16.7, that is, to output the U phase alone, to fix \bar{U} phase to "H", to fix the U phase to "H," or to output the \bar{U} phase alone.

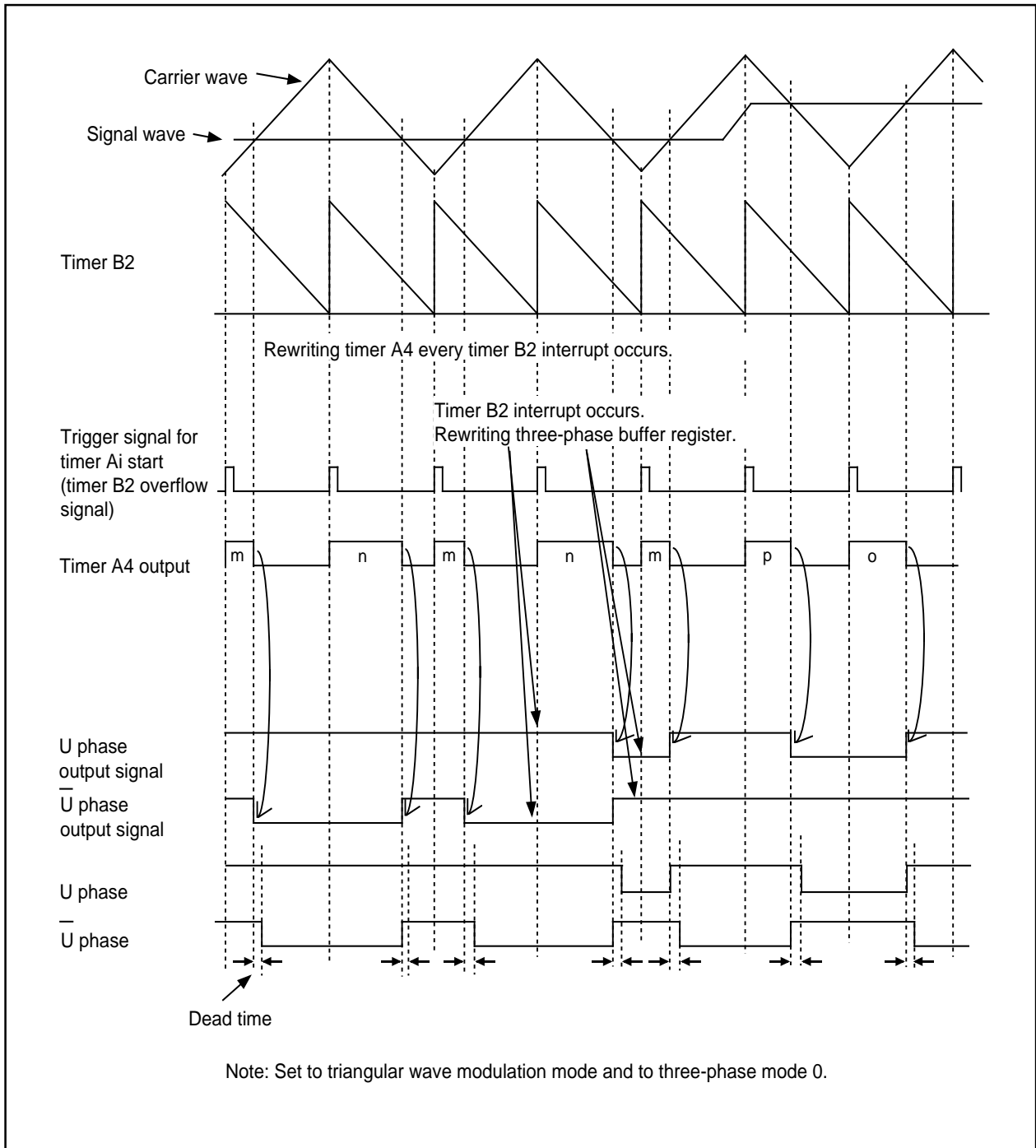

Figure 1.16.7. Timing chart of operation (2)

Sawtooth modulation

To generate a PWM waveform of sawtooth wave modulation, set "1" in the modulation mode select bit (bit 6 at 0348₁₆). Also, set "0" in the timers A4-1, A1-1, and A2-1 control bit (bit 1 at 0349₁₆). In this mode, the timer registers of timers A4, A1, and A2 comprise conventional timers A4, A1, and A2 alone, and reload the corresponding timer register's content to the counter every time the timer B2 counter's content becomes 0000₁₆. The effective interrupt output specification bit (bit 1 at 0348₁₆) and the effective interrupt output polarity select bit (bit 0 at 0348₁₆) go nullified.

An example of U phase waveform is shown in Figure 1.16.8, and the description of waveform output workings is given below. Set "1" in DU0 (bit 0 at 034A₁₆), and set "0" in DUB0 (bit 1 at 034A₁₆). In addition, set "0" in DU1 (bit 0 at 034A₁₆) and set "1" in DUB1 (bit 1 at 034A₁₆).

When the timer B2 counter's content becomes 0000₁₆, timer B2 generates an interrupt, and timer A4 starts outputting one-shot pulses at the same time. In this instance, the contents of the three-phase buffer registers DU1 and DU0 are set in the three-phase output shift register (U phase), and the contents of DUB1 and DUB0 are set in the three-phase output shift register (\bar{U} phase). After this, the three-phase buffer register's content is set in the three-phase shift register every time the timer B2 counter's content becomes 0000₁₆.

The value of DU0 and that of DUB0 are output to the U terminal (P80) and to the \bar{U} terminal (P81) respectively. When the timer A4 counter counts the value written to timer A4 (038F₁₆, 038E₁₆) and when timer A4 finishes outputting one-shot pulses, the three-phase output shift register's content is shifted one position, and the value of DU1 and that of DUB1 are output to the U phase output signal and to the \bar{U} output signal respectively. At this time, one-shot pulses are output from the timer for setting dead time used for setting the time over which the "L" level of the U phase waveform doesn't lap over the "L" level of the \bar{U} phase waveform, which has the opposite phase of the former. The U phase waveform output that started from the "H" level keeps its level until the timer for setting dead time finishes outputting one-shot pulses even though the three-phase output shift register's content changes from "1" to "0" by the effect of the one-shot pulses. When the timer for setting dead time finishes outputting one-shot pulses, 0 already shifted in the three-phase shift register goes effective, and the U phase waveform changes to the "L" level. When the timer B2 counter's content becomes 0000₁₆, the contents of the three-phase buffer registers DU1 and DU0 are set in the three-phase output shift register (U phase), and the contents of DUB1 and DUB0 are set in the three-phase output shift register (\bar{U} phase) again.

A U phase waveform is generated by these workings repeatedly. With the exception that the three-phase output shift register on the \bar{U} phase side is used, the workings in generating a \bar{U} phase waveform, which has the opposite phase of the U phase waveform, are the same as in generating a U phase waveform. In this way, a waveform can be picked up from the applicable terminal in a manner in which the "L" level of the U phase waveform doesn't lap over that of the \bar{U} phase waveform, which has the opposite phase of the U phase waveform. The width of the "L" level too can be adjusted by varying the values of timer B2 and timer A4. In dealing with the V and W phases, and \bar{V} and \bar{W} phases, the latter are of opposite phase of the former, have the corresponding timers work similarly to dealing with the U and \bar{U} phases to generate an intended waveform.

Setting "1" both in DUB0 and in DUB1 provides a means to output the U phase alone and to fix the \bar{U} phase output to "H" as shown in Figure 1.16.9.

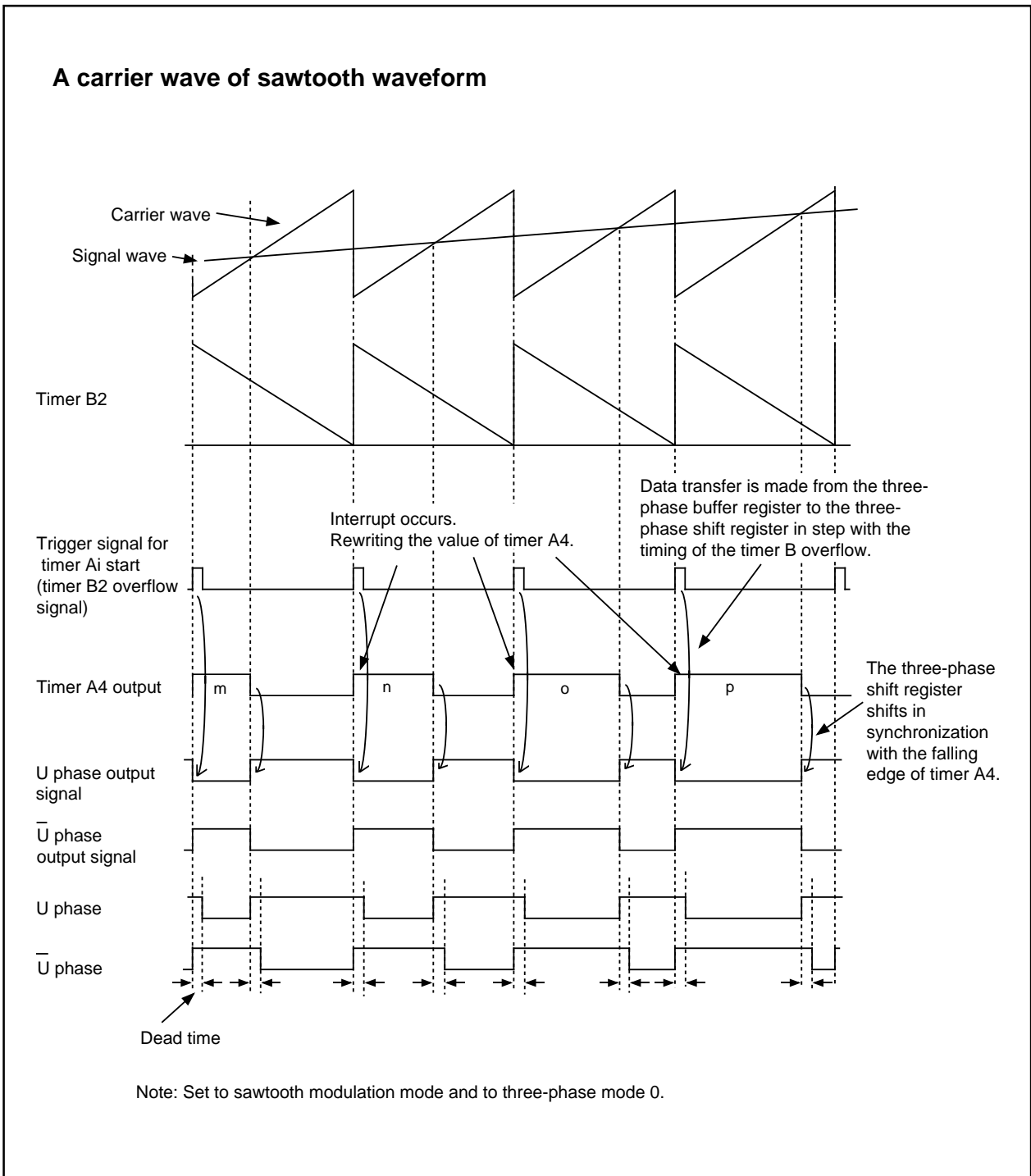

Figure 1.16.8. Timing chart of operation (3)

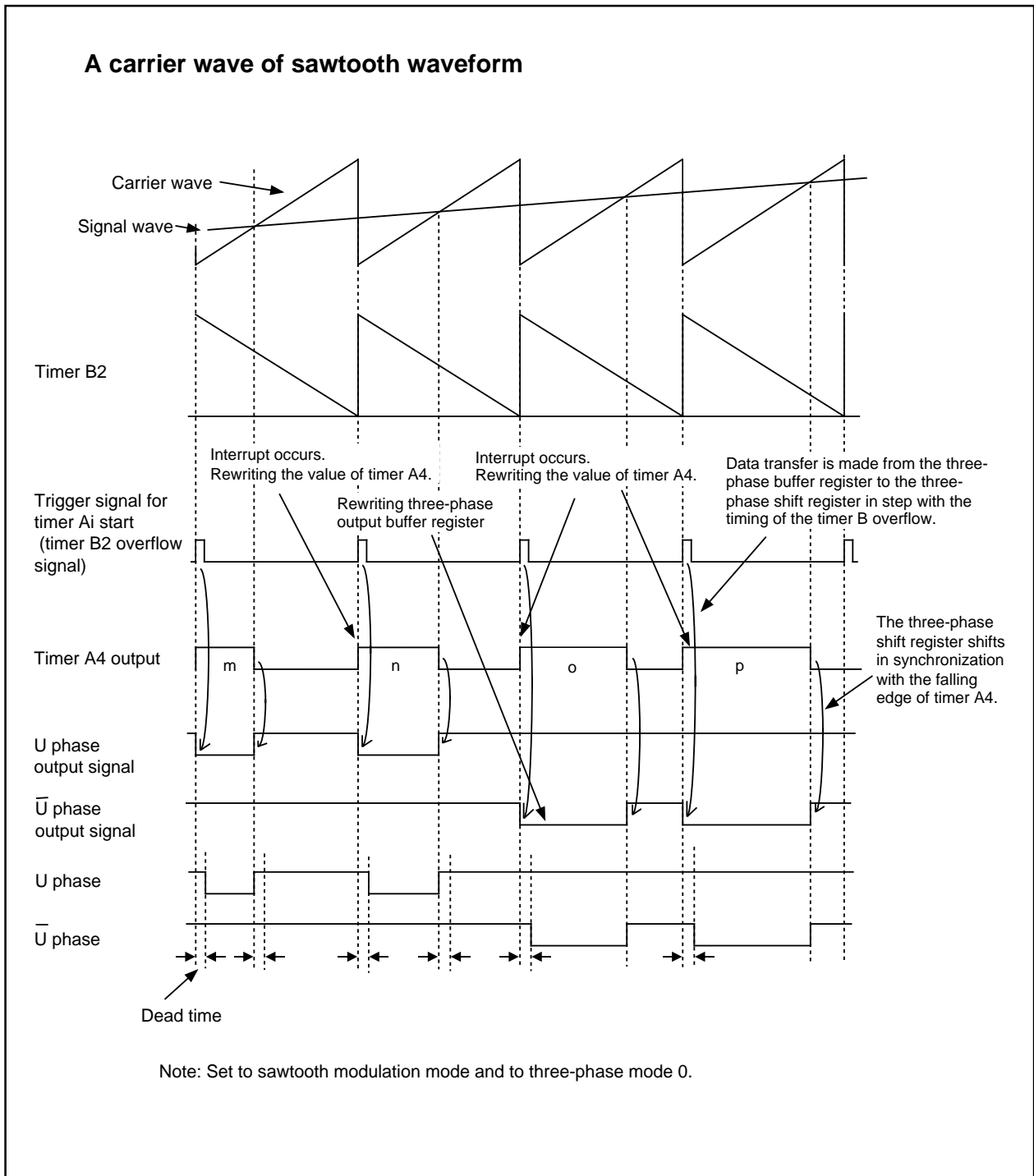

Figure 1.16.9. Timing chart of operation (4)

Serial I/O

Serial I/O is configured as five channels: UART0, UART1, UART2, S I/O3 and S I/O4.

UART0 to 2

UART0, UART1 and UART2 each have an exclusive timer to generate a transfer clock, so they operate independently of each other.

Figure 1.17.1 shows the block diagram of UART0, UART1 and UART2. Figures 1.17.2 and 1.17.3 show the block diagram of the transmit/receive unit.

UART_i (i = 0 to 2) has two operation modes: a clock synchronous serial I/O mode and a clock asynchronous serial I/O mode (UART mode). The contents of the serial I/O mode select bits (bits 0 to 2 at addresses 03A0₁₆, 03A8₁₆ and 0378₁₆) determine whether UART_i is used as a clock synchronous serial I/O or as a UART. Although a few functions are different, UART0, UART1 and UART2 have almost the same functions. UART2, in particular, is used for the SIM interface with some extra settings added in clock-asynchronous serial I/O mode (Note). It also has the bus collision detection function that generates an interrupt request if the Tx_D pin and the Rx_D pin are different in level.

Table 1.17.1 shows the comparison of functions of UART0 through UART2, and Figures 1.17.4 to 1.17.9 show the registers related to UART_i.

Note: SIM : Subscriber Identity Module

Table 1.17.1. Comparison of functions of UART0 through UART2

Function	UART0	UART1	UART2
CLK polarity selection	Possible (Note 1)	Possible (Note 1)	Possible (Note 1)
LSB first / MSB first selection	Possible (Note 1)	Possible (Note 1)	Possible (Note 2)
Continuous receive mode selection	Possible (Note 1)	Possible (Note 1)	Possible (Note 1)
Transfer clock output from multiple pins selection	Impossible	Possible (Note 1)	Impossible
Serial data logic switch	Impossible	Impossible	Possible (Note 4)
Sleep mode selection	Possible (Note 3)	Possible (Note 3)	Impossible
TxD, Rx _D I/O polarity switch	Impossible	Impossible	Possible
TxD, Rx _D port output format	CMOS output	CMOS output	N-channel open-drain output
Parity error signal output	Impossible	Impossible	Possible (Note 4)
Bus collision detection	Impossible	Impossible	Possible

Note 1: Only when clock synchronous serial I/O mode.

Note 2: Only when clock synchronous serial I/O mode and 8-bit UART mode.

Note 3: Only when UART mode.

Note 4: Using for SIM interface.

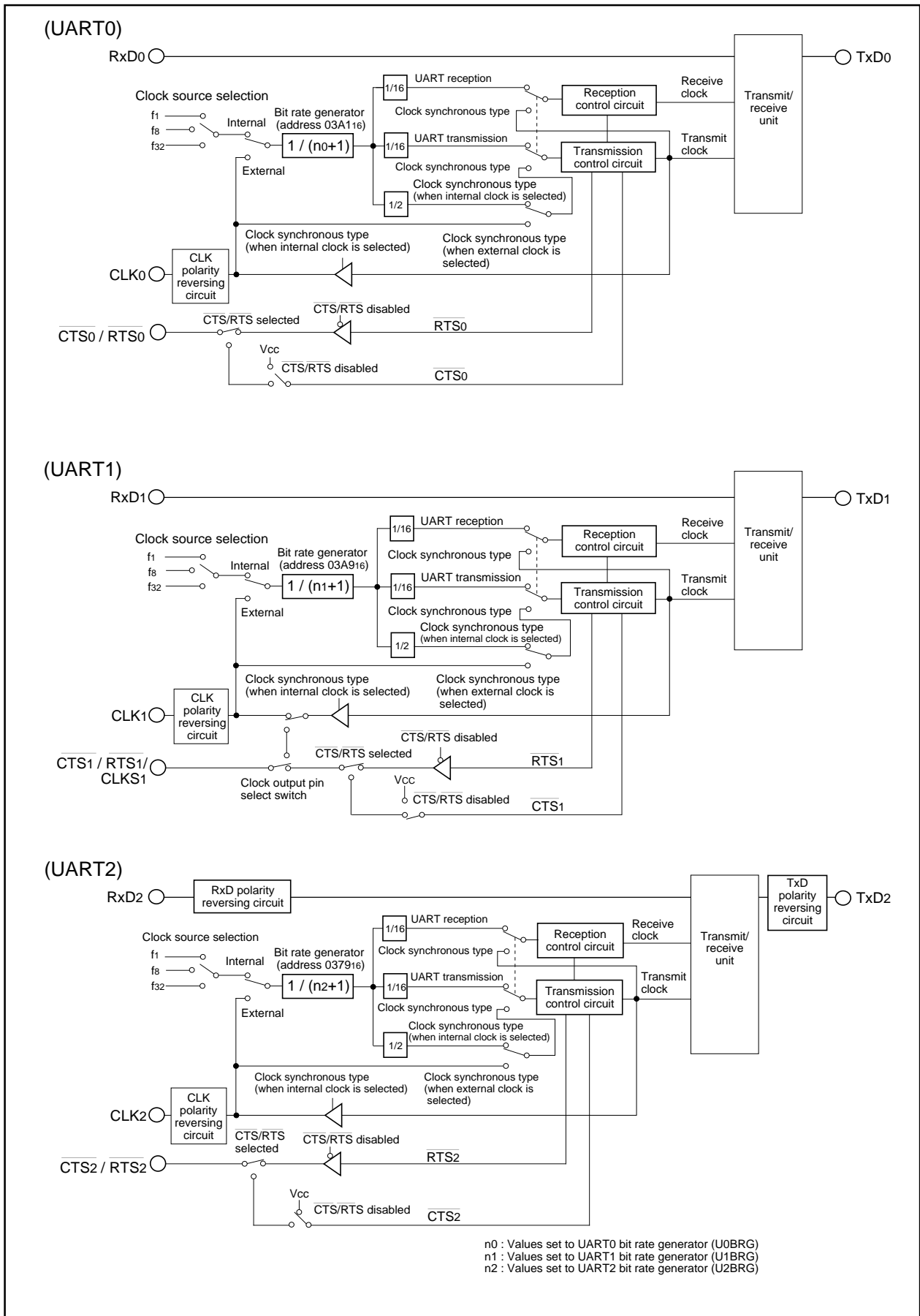

Figure 1.17.1. Block diagram of UARTi (i = 0 to 2)

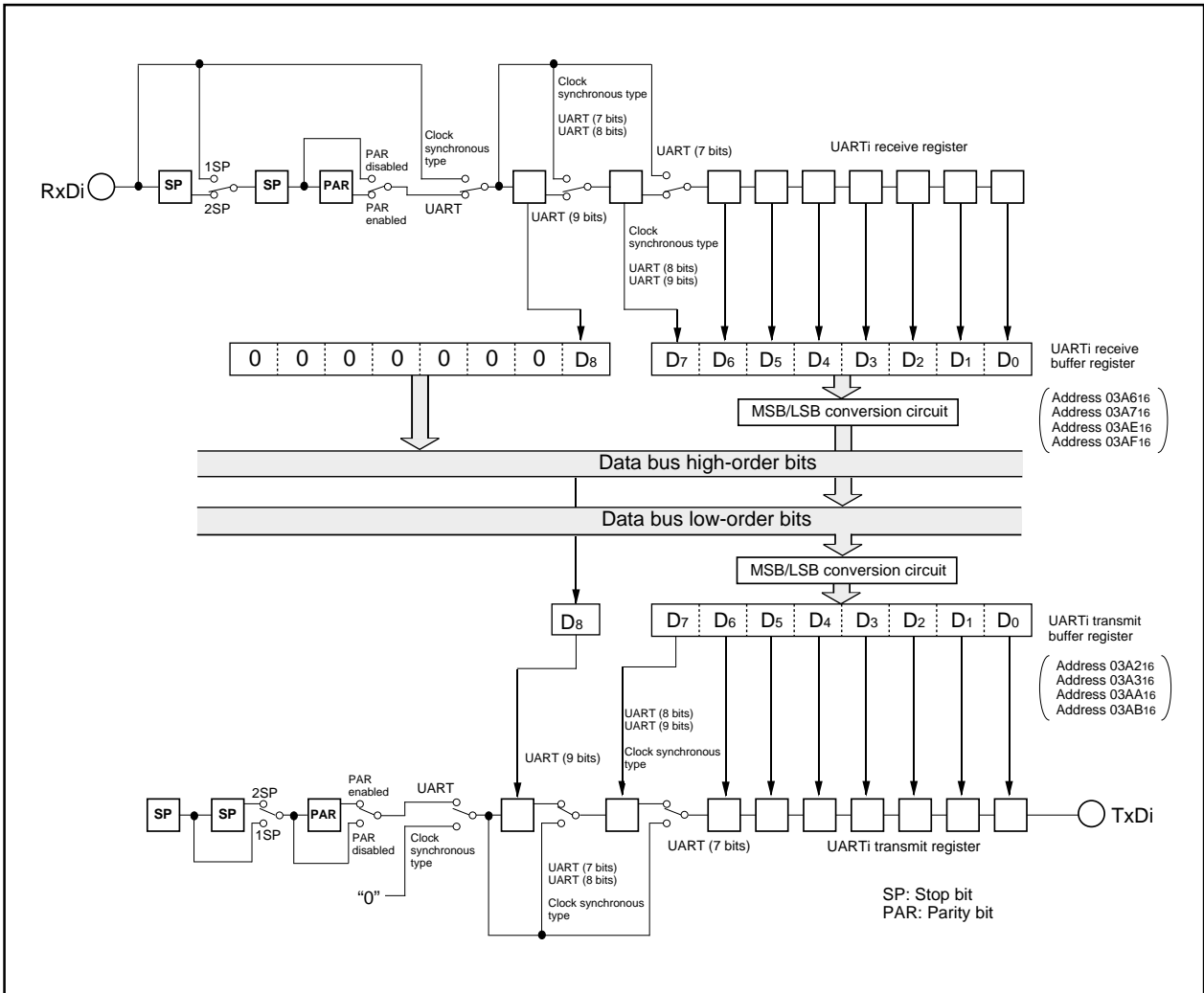

Figure 1.17.2. Block diagram of UARTi (i = 0, 1) transmit/receive unit

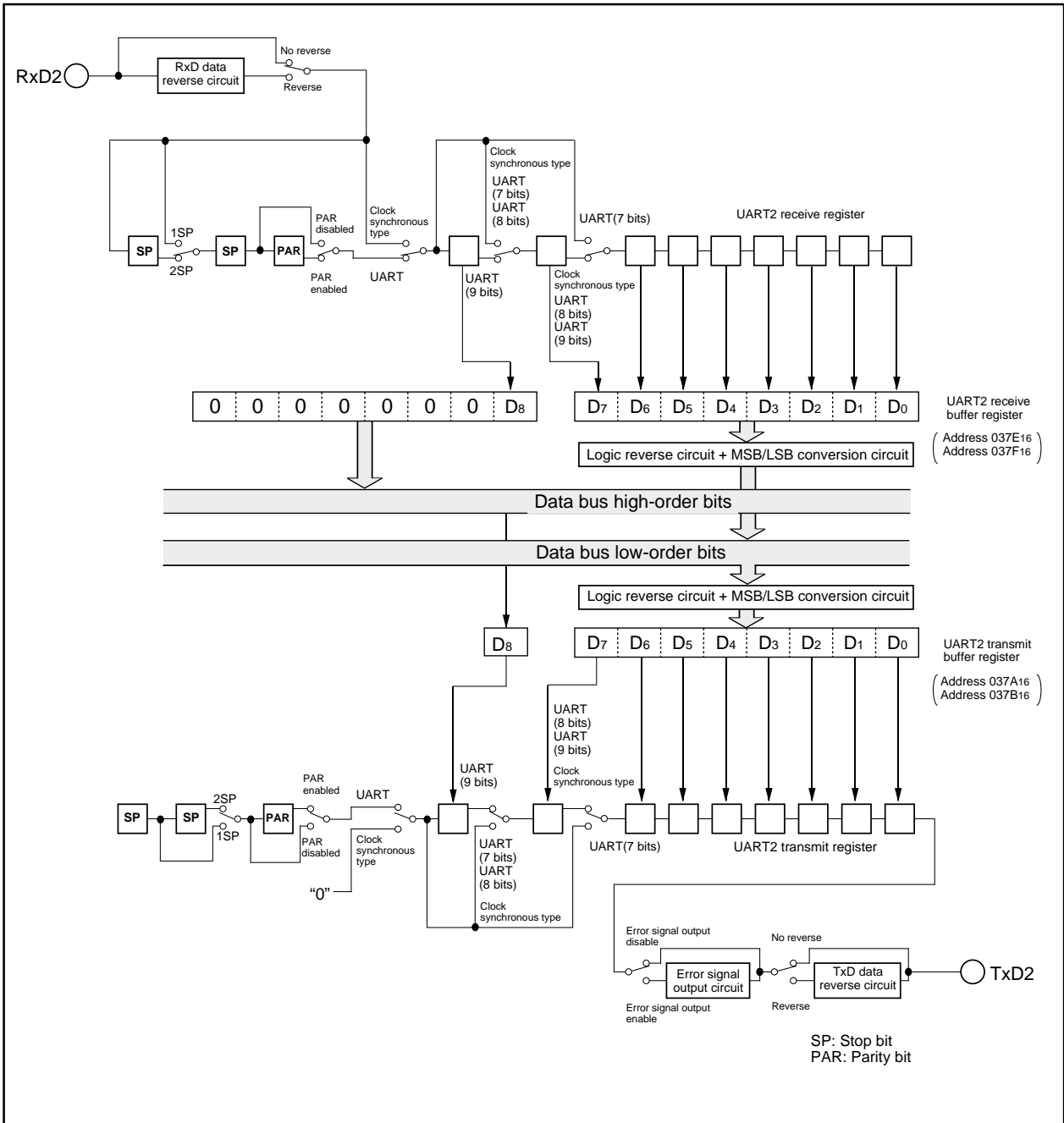

Figure 1.17.3. Block diagram of UART2 transmit/receive unit

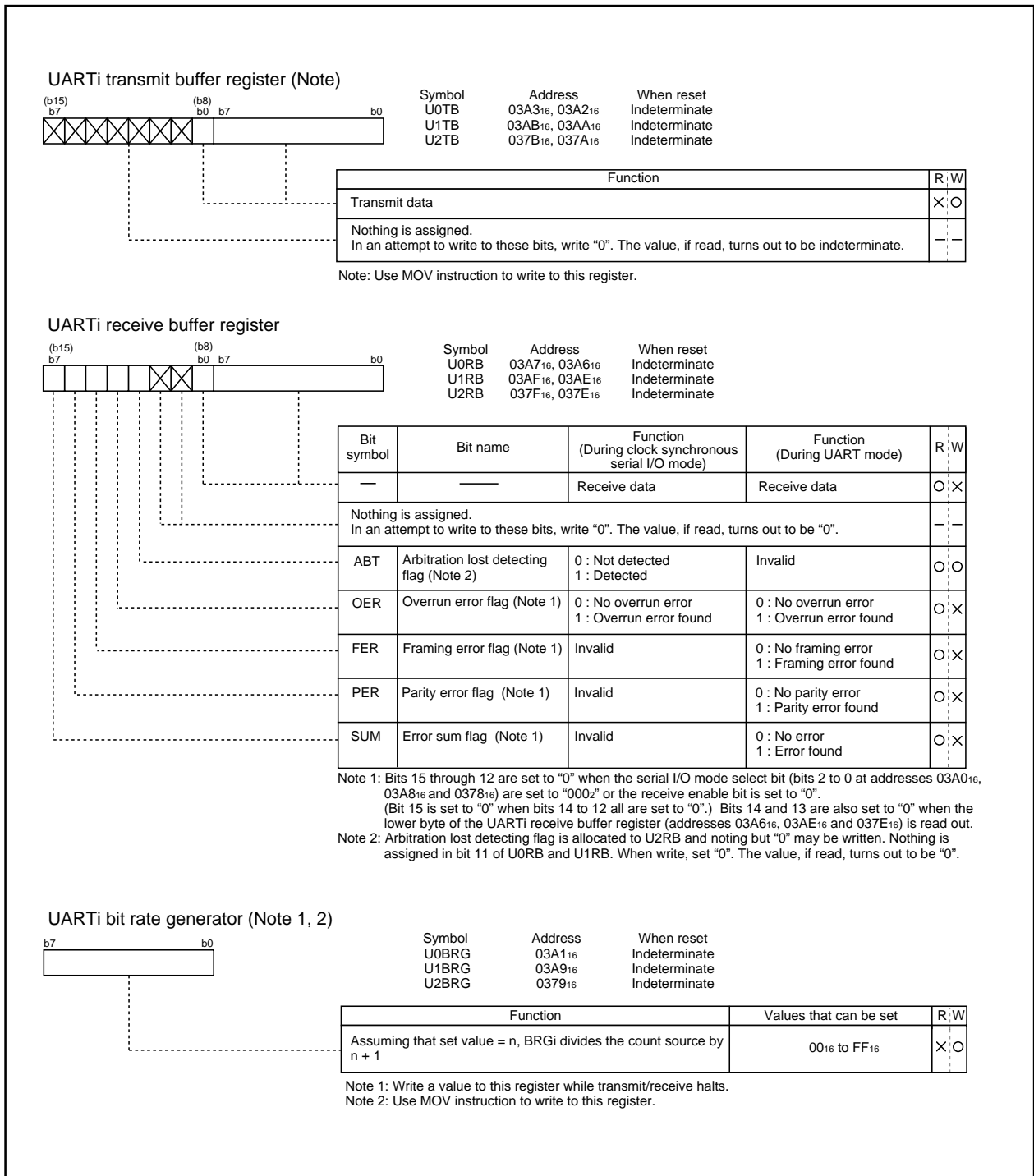

Figure 1.17.4. Serial I/O-related registers (1)

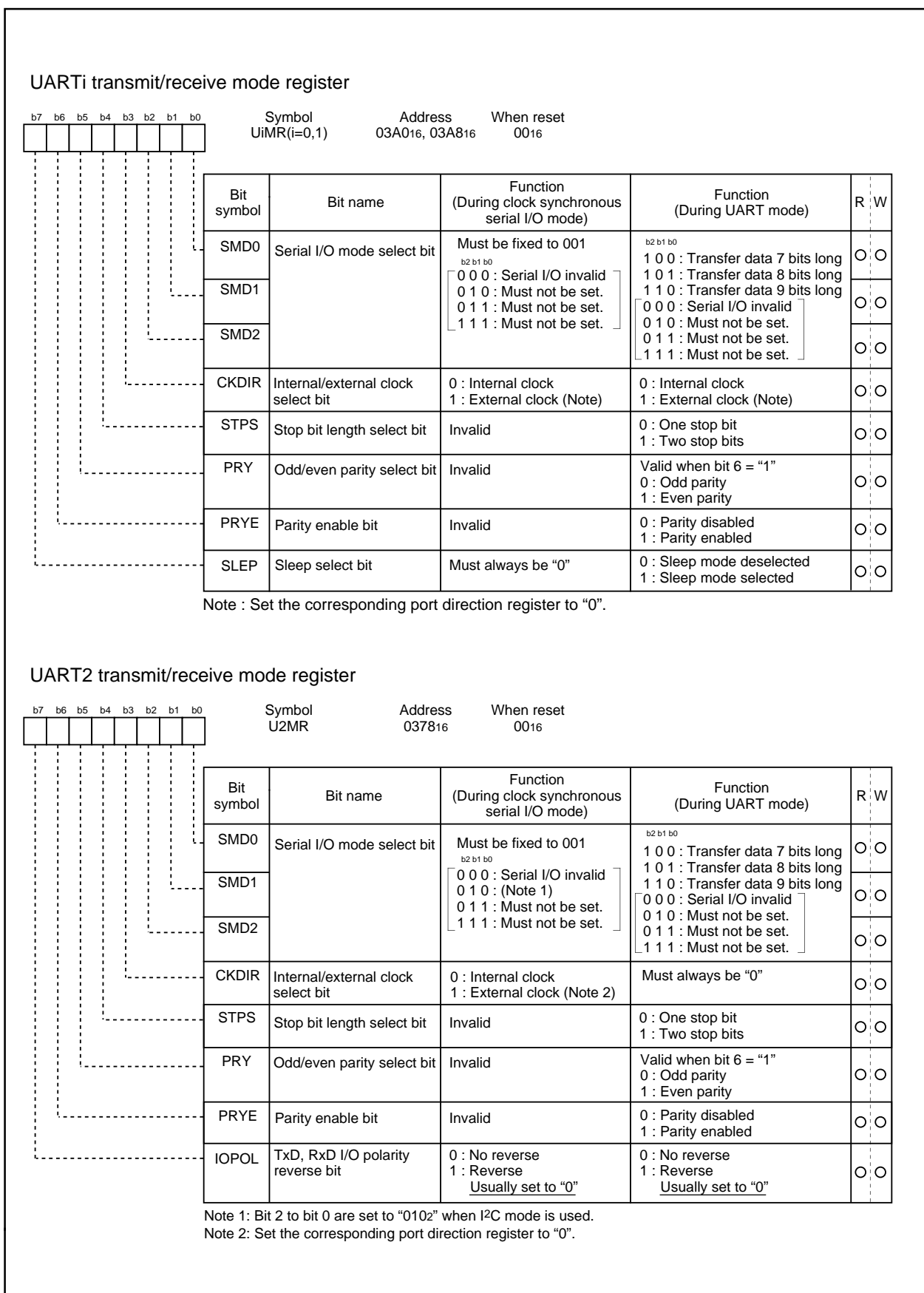

Figure 1.17.5. Serial I/O-related registers (2)

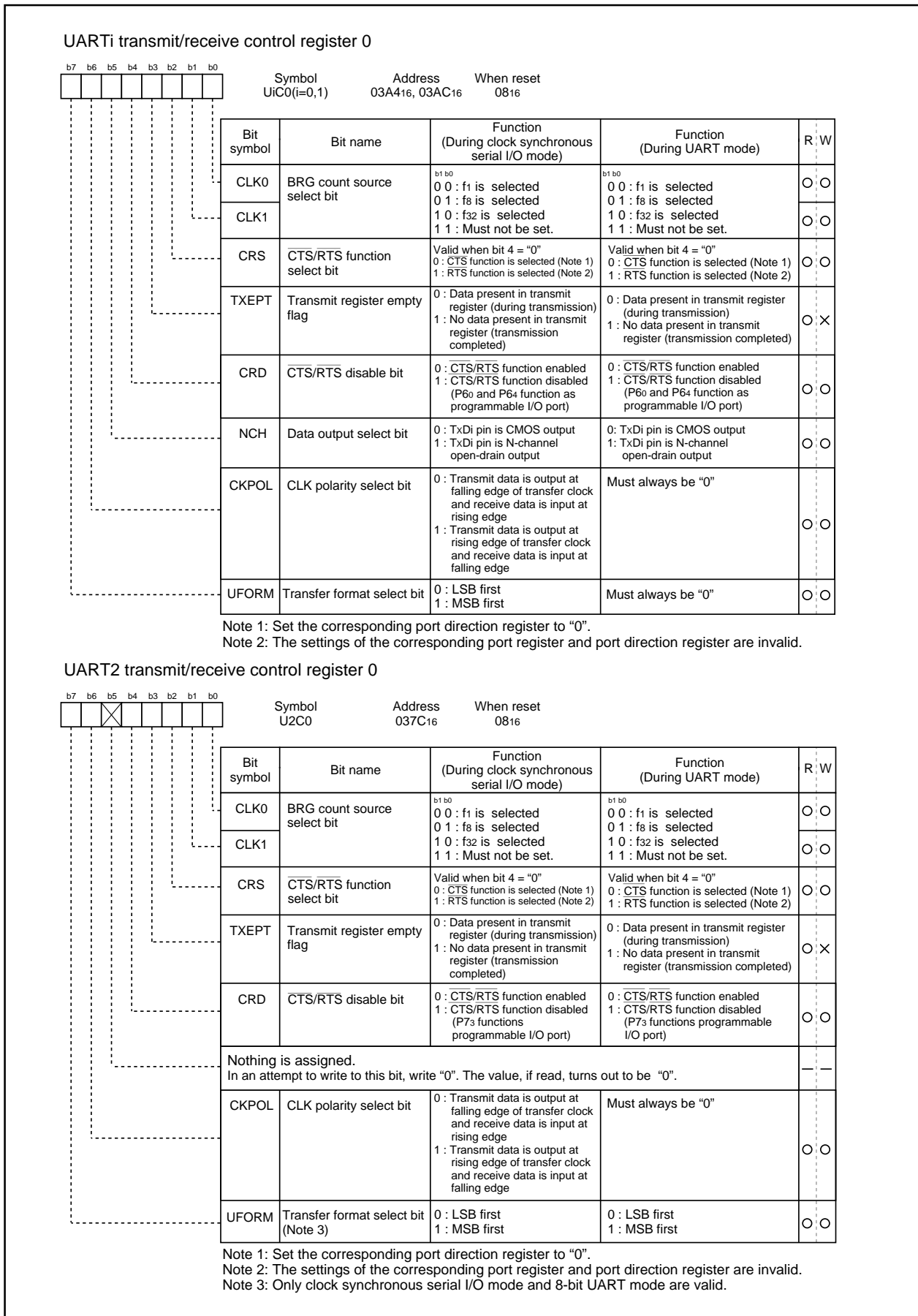

Figure 1.17.6. Serial I/O-related registers (3)

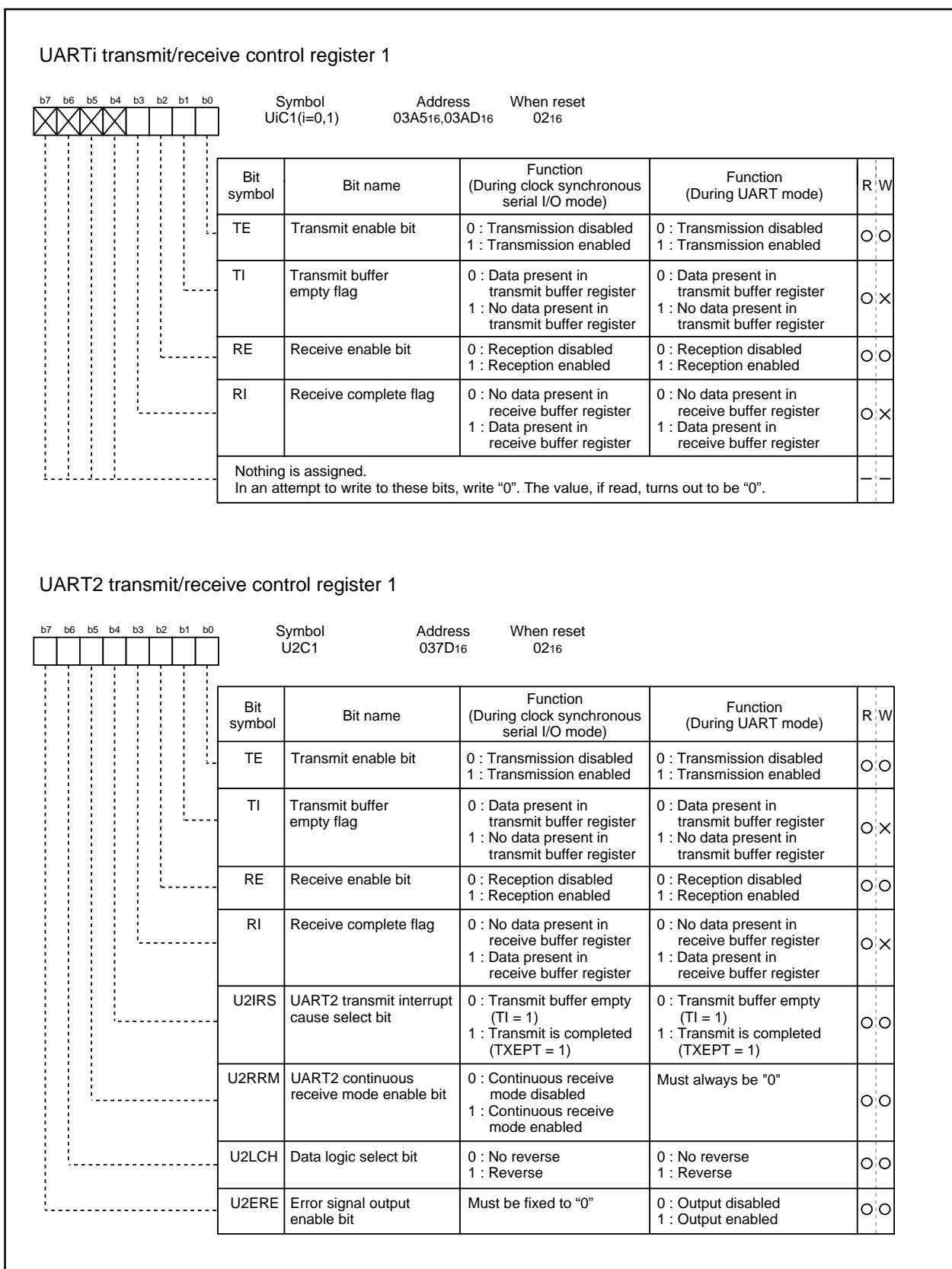
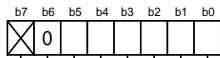

Figure 1.17.7. Serial I/O-related registers (4)

UART transmit/receive control register 2



Symbol: UCON
 Address: 03B0₁₆
 When reset: X000000₂

Bit symbol	Bit name	Function (During clock synchronous serial I/O mode)	Function (During UART mode)	R : W
U0IRS	UART0 transmit interrupt cause select bit	0 : Transmit buffer empty (TI = 1) 1 : Transmission completed (TXEPT = 1)	0 : Transmit buffer empty (TI = 1) 1 : Transmission completed (TXEPT = 1)	○ ○
U1IRS	UART1 transmit interrupt cause select bit	0 : Transmit buffer empty (TI = 1) 1 : Transmission completed (TXEPT = 1)	0 : Transmit buffer empty (TI = 1) 1 : Transmission completed (TXEPT = 1)	○ ○
U0RRM	UART0 continuous receive mode enable bit	0 : Continuous receive mode disabled 1 : Continuous receive mode enable	Must always be "0"	○ ○
U1RRM	UART1 continuous receive mode enable bit	0 : Continuous receive mode disabled 1 : Continuous receive mode enabled	Must always be "0"	○ ○
CLKMD0	CLK/CLKS select bit 0	Valid when bit 5 = "1" 0 : Clock output to CLK1 1 : Clock output to CLKS1	Invalid	○ ○
CLKMD1	CLK/CLKS select bit 1 (Note)	0 : Normal mode (CLK output is CLK1 only) 1 : Transfer clock output from multiple pins function selected	Must always be "0"	○ ○
	Reserved bit	Must always be set to "0"		○ ○
	Nothing is assigned. In an attempt to write to this bit, write "0". The value, if read, turns out to be indeterminate.			— —

Note: When using multiple pins to output the transfer clock, the following requirements must be met:
 • UART1 internal/external clock select bit (bit 3 at address 03A8₁₆) = "0".

UART2 special mode register

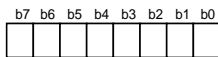

Symbol: U2SMR
 Address: 0377₁₆
 When reset: 80₁₆

Bit symbol	Bit name	Function (During clock synchronous serial I/O mode)	Function (During UART mode)	R : W
IICM	I ² C mode select bit	0 : Normal mode 1 : I ² C mode	Must always be "0"	○ ○
ABC	Arbitration lost detecting flag control bit	0 : Update per bit 1 : Update per byte	Must always be "0"	○ ○
BBS	Bus busy flag	0 : STOP condition detected 1 : START condition detected	Must always be "0"	○ ○ (Note1)
LSYN	SCLL sync output enable bit	0 : Disabled 1 : Enabled	Must always be "0"	○ ○
ABSCS	Bus collision detect sampling clock select bit	Must always be "0"	0 : Rising edge of transfer clock 1 : Underflow signal of timer A0	○ ○
ACSE	Auto clear function select bit of transmit enable bit	Must always be "0"	0 : No auto clear function 1 : Auto clear at occurrence of bus collision	○ ○
SSS	Transmit start condition select bit	Must always be "0"	0 : Ordinary 1 : Falling edge of RxD2	○ ○
SDDS	SDA digital delay select bit (Note 2)	0 : Must always be "0" when not using I ² C mode 1 : Digital delay output is selected	Must always be "0"	○ ○

Note 1: Nothing but "0" may be written.
 Note 2: When not in I²C mode, do not set this bit by writing a "1". During normal mode, fix it to "0". When this bit = "0", UART2 special mode register 3 (U2SMR3 at address 0375₁₆) bits 7 to 5 (DL2 to DL0 = SDA digital delay setup bits) are initialized to "000". Also, when SDDS = "0", the U2SMR3 register cannot be read or written to.

Figure 1.17.8. Serial I/O-related registers (5)

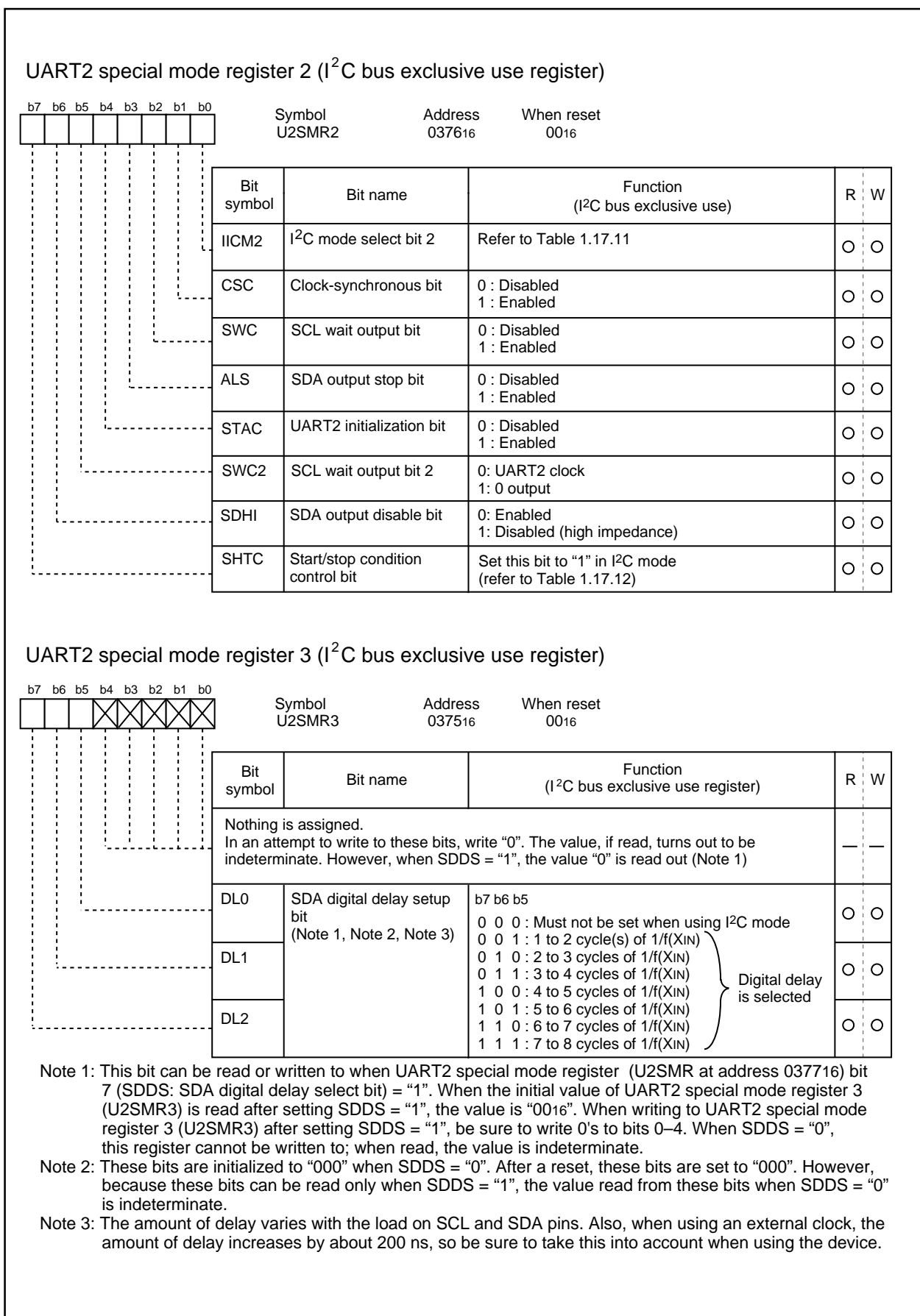

Figure 1.17.9. Serial I/O-related registers (6)

(1) Clock synchronous serial I/O mode

The clock synchronous serial I/O mode uses a transfer clock to transmit and receive data. Tables 1.17.2 and 1.17.3 list the specifications of the clock synchronous serial I/O mode. Figure 1.17.10 shows the UART_i transmit/receive mode register.

Table 1.17.2. Specifications of clock synchronous serial I/O mode (1)

Item	Specification
Transfer data format	<ul style="list-style-type: none"> Transfer data length: 8 bits
Transfer clock	<ul style="list-style-type: none"> When internal clock is selected (bit 3 at addresses 03A0₁₆, 03A8₁₆, 0378₁₆ = "0") : $f_i / 2(n+1)$ (Note 1) $f_i = f_1, f_8, f_{32}$ When external clock is selected (bit 3 at addresses 03A0₁₆, 03A8₁₆, 0378₁₆ = "1") : Input from CLK_i pin
Transmission/reception control	<ul style="list-style-type: none"> CTS function, $\overline{\text{RTS}}$ function, CTS and $\overline{\text{RTS}}$ function invalid: selectable
Transmission start condition	<ul style="list-style-type: none"> To start transmission, the following requirements must be met: <ul style="list-style-type: none"> Transmit enable bit (bit 0 at addresses 03A5₁₆, 03AD₁₆, 037D₁₆) = "1" Transmit buffer empty flag (bit 1 at addresses 03A5₁₆, 03AD₁₆, 037D₁₆) = "0" When $\overline{\text{CTS}}$ function selected, $\overline{\text{CTS}}$ input level = "L" Furthermore, if external clock is selected, the following requirements must also be met: <ul style="list-style-type: none"> CLK_i polarity select bit (bit 6 at addresses 03A4₁₆, 03AC₁₆, 037C₁₆) = "0": CLK_i input level = "H" CLK_i polarity select bit (bit 6 at addresses 03A4₁₆, 03AC₁₆, 037C₁₆) = "1": CLK_i input level = "L"
Reception start condition	<ul style="list-style-type: none"> To start reception, the following requirements must be met: <ul style="list-style-type: none"> Receive enable bit (bit 2 at addresses 03A5₁₆, 03AD₁₆, 037D₁₆) = "1" Transmit enable bit (bit 0 at addresses 03A5₁₆, 03AD₁₆, 037D₁₆) = "1" Transmit buffer empty flag (bit 1 at addresses 03A5₁₆, 03AD₁₆, 037D₁₆) = "0" Furthermore, if external clock is selected, the following requirements must also be met: <ul style="list-style-type: none"> CLK_i polarity select bit (bit 6 at addresses 03A4₁₆, 03AC₁₆, 037C₁₆) = "0": CLK_i input level = "H" CLK_i polarity select bit (bit 6 at addresses 03A4₁₆, 03AC₁₆, 037C₁₆) = "1": CLK_i input level = "L"
Interrupt request generation timing	<ul style="list-style-type: none"> When transmitting <ul style="list-style-type: none"> Transmit interrupt cause select bit (bits 0, 1 at address 03B0₁₆, bit 4 at address 037D₁₆) = "0": Interrupts requested when data transfer from UART_i transfer buffer register to UART_i transmit register is completed Transmit interrupt cause select bit (bits 0, 1 at address 03B0₁₆, bit 4 at address 037D₁₆) = "1": Interrupts requested when data transmission from UART_i transfer register is completed When receiving <ul style="list-style-type: none"> Interrupts requested when data transfer from UART_i receive register to UART_i receive buffer register is completed
Error detection	<ul style="list-style-type: none"> Overrun error (Note 2) This error occurs when the next data is ready before contents of UART_i receive buffer register are read out

Note 1: "n" denotes the value 00₁₆ to FF₁₆ that is set to the UART bit rate generator.

Note 2: If an overrun error occurs, the UART_i receive buffer will have the next data written in. Note also that the UART_i receive interrupt request bit does not change.

Table 1.17.3. Specifications of clock synchronous serial I/O mode (2)

Item	Specification
Select function	<ul style="list-style-type: none"><li data-bbox="507 342 1426 450">• CLK polarity selection Whether transmit data is output/input timing at the rising edge or falling edge of the transfer clock can be selected<li data-bbox="507 461 1426 533">• LSB first/MSB first selection Whether transmission/reception begins with bit 0 or bit 7 can be selected<li data-bbox="507 544 1426 616">• Continuous receive mode selection Reception is enabled simultaneously by a read from the receive buffer register<li data-bbox="507 627 1426 734">• Transfer clock output from multiple pins selection (UART1) UART1 transfer clock can be chosen by software to be output from one of the two pins set<li data-bbox="507 745 1426 853">• Switching serial data logic (UART2) Whether to reverse data in writing to the transmission buffer register or reading the reception buffer register can be selected.<li data-bbox="507 864 1426 967">• TxD, RxD I/O polarity reverse (UART2) This function is reversing TxD port output and RxD port input. All I/O data level is reversed.

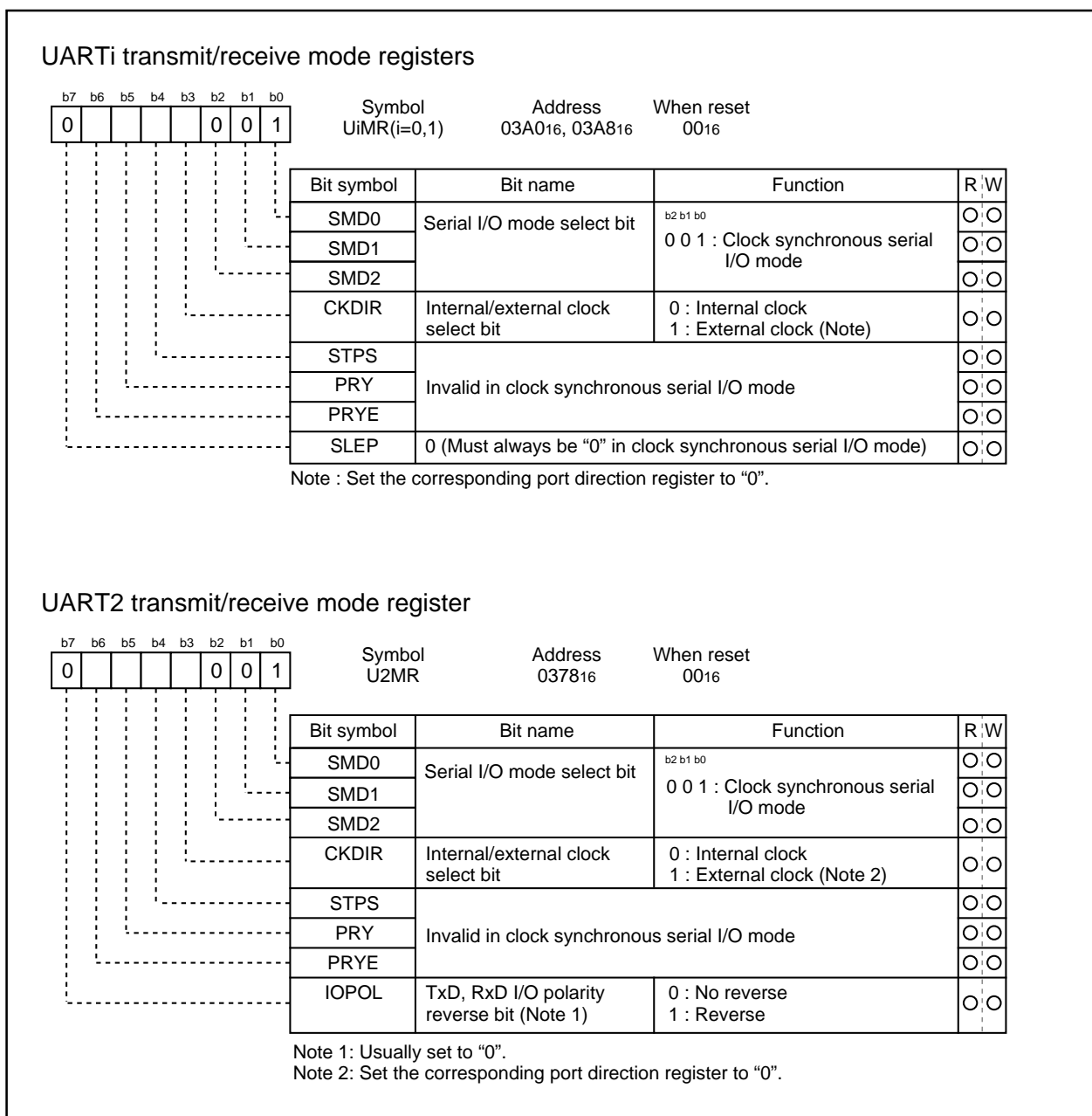

Figure 1.17.10. UARTi transmit/receive mode register in clock synchronous serial I/O mode

Clock synchronous serial I/O mode

Table 1.17.4 lists the functions of the input/output pins during clock synchronous serial I/O mode. This table shows the pin functions when the transfer clock output from multiple pins function is not selected. Note that for a period from when the UARTi operation mode is selected to when transfer starts, the TxDi pin outputs an "H". (If the N-channel open-drain is selected, this pin is in floating state.)

Table 1.17.4. Input/output pin functions in clock synchronous serial I/O mode(when transfer clock output from multiple pins is not selected)

Pin name	Function	Method of selection
TxDi (P63, P67, P70)	Serial data output	(Outputs dummy data when performing reception only)
RxDi (P62, P66, P71)	Serial data input	Port P62, P66 and P71 direction register (bits 2 and 6 at address 03EE16, bit 1 at address 03EF16) = "0" (Can be used as an input port when performing transmission only)
CLKi (P61, P65, P72)	Transfer clock output	Internal/external clock select bit (bit 3 at address 03A016, 03A816, 037816) = "0"
	Transfer clock input	Internal/external clock select bit (bit 3 at address 03A016, 03A816, 037816) = "1" Port P61, P65 and P72 direction register (bits 1 and 5 at address 03EE16, bit 2 at address 03EF16) = "0"
$\overline{\text{CTS}}/\overline{\text{RTS}}$ (P60, P64, P73)	$\overline{\text{CTS}}$ input	$\overline{\text{CTS}}/\overline{\text{RTS}}$ disable bit (bit 4 at address 03A416, 03AC16, 037C16) = "0" $\overline{\text{CTS}}/\overline{\text{RTS}}$ function select bit (bit 2 at address 03A416, 03AC16, 037C16) = "0" Port P60, P64 and P73 direction register (bits 0 and 4 at address 03EE16, bit 3 at address 03EF16) = "0"
	$\overline{\text{RTS}}$ output	$\overline{\text{CTS}}/\overline{\text{RTS}}$ disable bit (bit 4 at address 03A416, 03AC16, 037C16) = "0" $\overline{\text{CTS}}/\overline{\text{RTS}}$ function select bit (bit 2 at address 03A416, 03AC16, 037C16) = "1"
	Programmable I/O port	$\overline{\text{CTS}}/\overline{\text{RTS}}$ disable bit (bit 4 at address 03A416, 03AC16, 037C16) = "1"

• Example of transmit timing (when internal clock is selected)

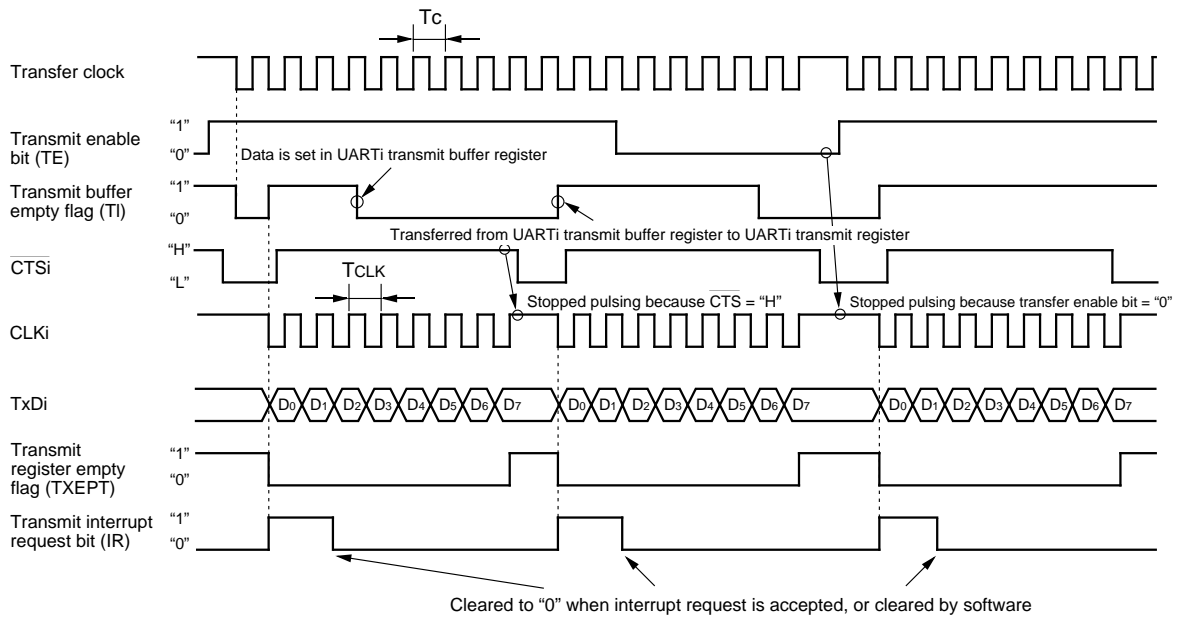

• Example of receive timing (when external clock is selected)

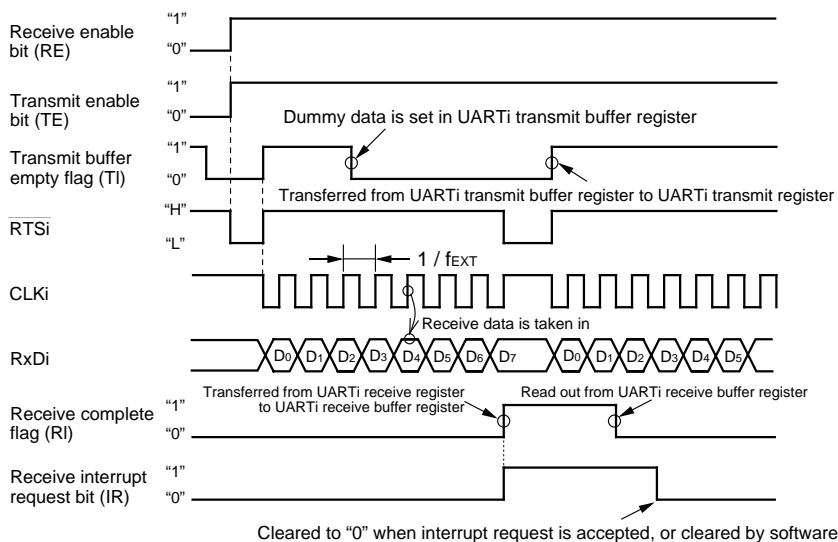

Figure 1.17.11. Typical transmit/receive timings in clock synchronous serial I/O mode

(a) Polarity select function

As shown in Figure 1.17.12, the CLK polarity select bit (bit 6 at addresses 03A4₁₆, 03AC₁₆, 037C₁₆) allows selection of the polarity of the transfer clock.

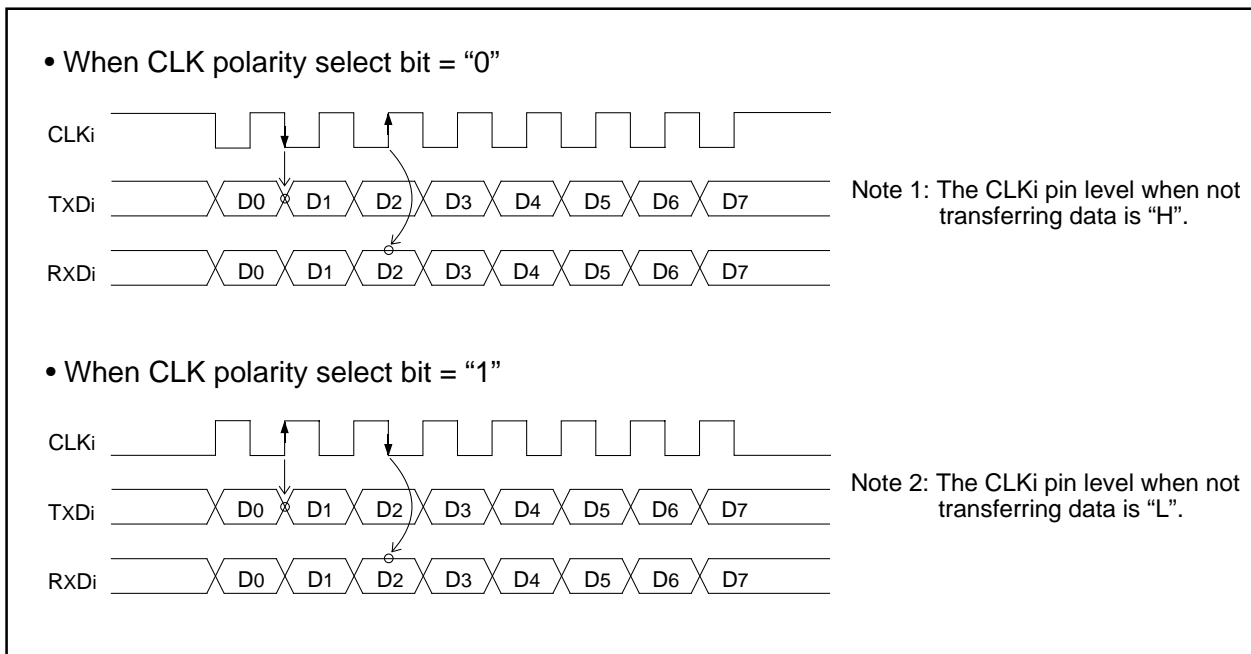

Figure 1.17.12. Polarity of transfer clock

(b) LSB first/MSB first select function

As shown in Figure 1.17.13, when the transfer format select bit (bit 7 at addresses 03A4₁₆, 03AC₁₆, 037C₁₆) = "0", the transfer format is "LSB first"; when the bit = "1", the transfer format is "MSB first".

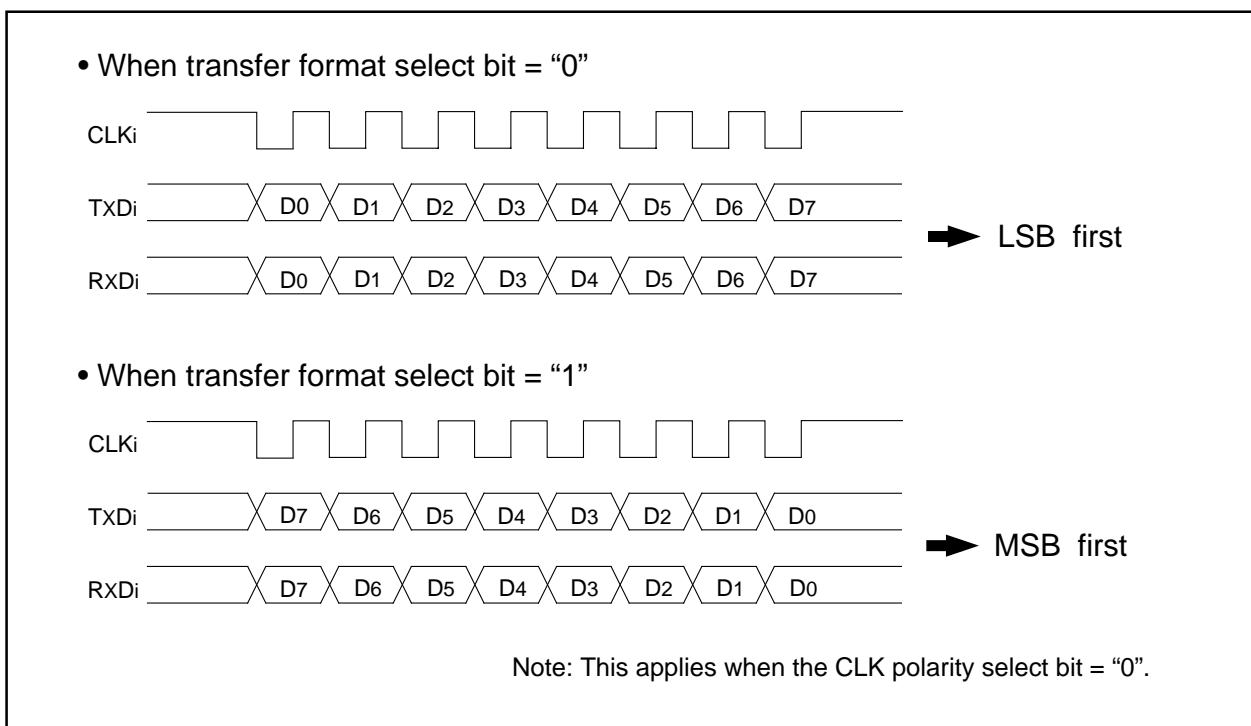

Figure 1.17.13. Transfer format

(c) Transfer clock output from multiple pins function (UART1)

This function allows the setting two transfer clock output pins and choosing one of the two to output a clock by using the CLK and CLKS select bit (bits 4 and 5 at address 03B016). (See Figure 1.17.14.) The multiple pins function is valid only when the internal clock is selected for UART1.

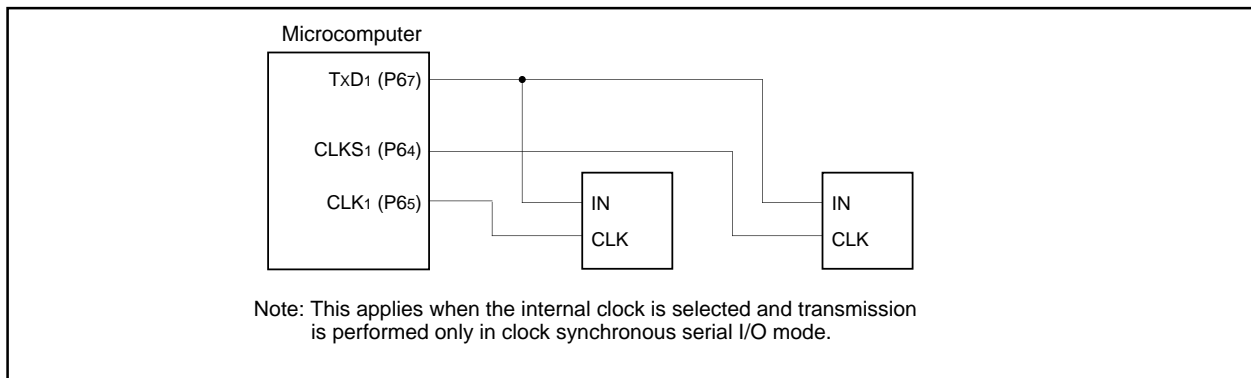

Figure 1.17.14. The transfer clock output from the multiple pins function usage

(d) Continuous receive mode

If the continuous receive mode enable bit (bits 2 and 3 at address 03B016, bit 5 at address 037D16) is set to "1", the unit is placed in continuous receive mode. In this mode, when the receive buffer register is read out, the unit simultaneously goes to a receive enable state without having to set dummy data to the transmit buffer register back again.

(e) Serial data logic switch function (UART2)

When the data logic select bit (bit6 at address 037D16) = "1", and writing to transmit buffer register or reading from receive buffer register, data is reversed. Figure 1.17.15 shows the example of serial data logic switch timing.

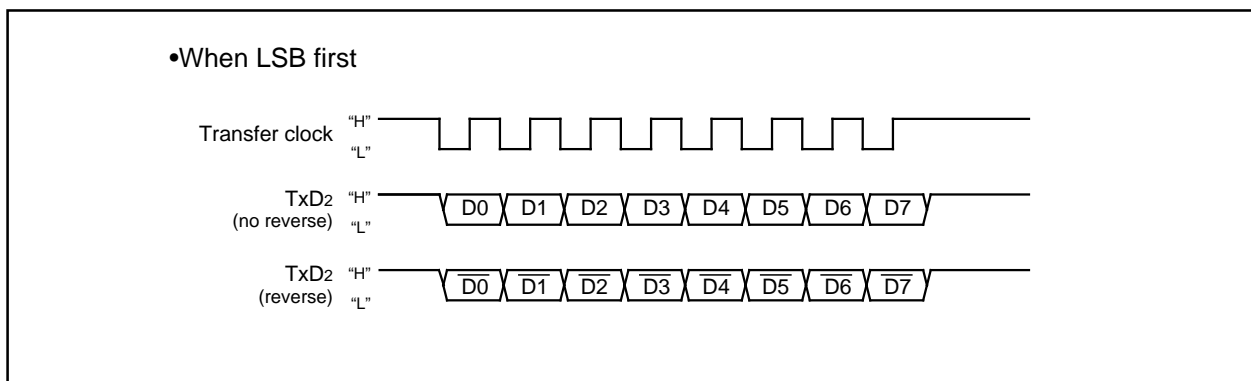

Figure 1.17.15. Serial data logic switch timing

(2) Clock asynchronous serial I/O (UART) mode

The UART mode allows transmitting and receiving data after setting the desired transfer rate and transfer data format. Tables 1.17.5 and 1.17.6 list the specifications of the UART mode. Figure 1.17.16 shows the UARTi transmit/receive mode register.

Table 1.17.5. Specifications of UART Mode (1)

Item	Specification
Transfer data format	<ul style="list-style-type: none"> • Character bit (transfer data): 7 bits, 8 bits, or 9 bits as selected • Start bit: 1 bit • Parity bit: Odd, even, or nothing as selected • Stop bit: 1 bit or 2 bits as selected
Transfer clock	<ul style="list-style-type: none"> • When internal clock is selected (bit 3 at addresses 03A0₁₆, 03A8₁₆, 0378₁₆ = "0") : $f_i/16(n+1)$ (Note 1) $f_i = f_1, f_8, f_{32}$ • When external clock is selected (bit 3 at addresses 03A0₁₆, 03A8₁₆ = "1") : $f_{EXT}/16(n+1)$ (Note 1) (Note 2) (Do not set external clock for UART2)
Transmission/reception control	<ul style="list-style-type: none"> • \overline{CTS} function, RTS function, \overline{CTS} and RTS function invalid: selectable
Transmission start condition	<ul style="list-style-type: none"> • To start transmission, the following requirements must be met: <ul style="list-style-type: none"> - Transmit enable bit (bit 0 at addresses 03A5₁₆, 03AD₁₆, 037D₁₆) = "1" - Transmit buffer empty flag (bit 1 at addresses 03A5₁₆, 03AD₁₆, 037D₁₆) = "0" - When \overline{CTS} function selected, \overline{CTS} input level = "L"
Reception start condition	<ul style="list-style-type: none"> • To start reception, the following requirements must be met: <ul style="list-style-type: none"> - Receive enable bit (bit 2 at addresses 03A5₁₆, 03AD₁₆, 037D₁₆) = "1" - Start bit detection
Interrupt request generation timing	<ul style="list-style-type: none"> • When transmitting <ul style="list-style-type: none"> - Transmit interrupt cause select bits (bits 0,1 at address 03B0₁₆, bit4 at address 037D₁₆) = "0": Interrupts requested when data transfer from UARTi transfer buffer register to UARTi transmit register is completed - Transmit interrupt cause select bits (bits 0, 1 at address 03B0₁₆, bit4 at address 037D₁₆) = "1": Interrupts requested when data transmission from UARTi transfer register is completed • When receiving <ul style="list-style-type: none"> - Interrupts requested when data transfer from UARTi receive register to UARTi receive buffer register is completed
Error detection	<ul style="list-style-type: none"> • Overrun error (Note 3) <p>This error occurs when the next data is ready before contents of UARTi receive buffer register are read out</p> • Framing error <p>This error occurs when the number of stop bits set is not detected</p> • Parity error <p>This error occurs when if parity is enabled, the number of 1's in parity and character bits does not match the number of 1's set</p> • Error sum flag <p>This flag is set (= 1) when any of the overrun, framing, and parity errors is encountered</p>

Note 1: 'n' denotes the value 00₁₆ to FF₁₆ that is set to the UARTi bit rate generator.

Note 2: f_{EXT} is input from the CLKi pin.

Note 3: If an overrun error occurs, the UARTi receive buffer will have the next data written in. Note also that the UARTi receive interrupt request bit does not change.

Table 1.17.6. Specifications of UART Mode (2)

Item	Specification
Select function	<ul style="list-style-type: none"><li data-bbox="507 342 1428 454">• Sleep mode selection (UART0, UART1) This mode is used to transfer data to and from one of multiple slave micro-computers<li data-bbox="507 465 1428 577">• Serial data logic switch (UART2) This function is reversing logic value of transferring data. Start bit, parity bit and stop bit are not reversed.<li data-bbox="507 589 1428 696">• TxD, RxD I/O polarity switch (UART2) This function is reversing TxD port output and RxD port input. All I/O data level is reversed.

Clock asynchronous serial I/O (UART) mode

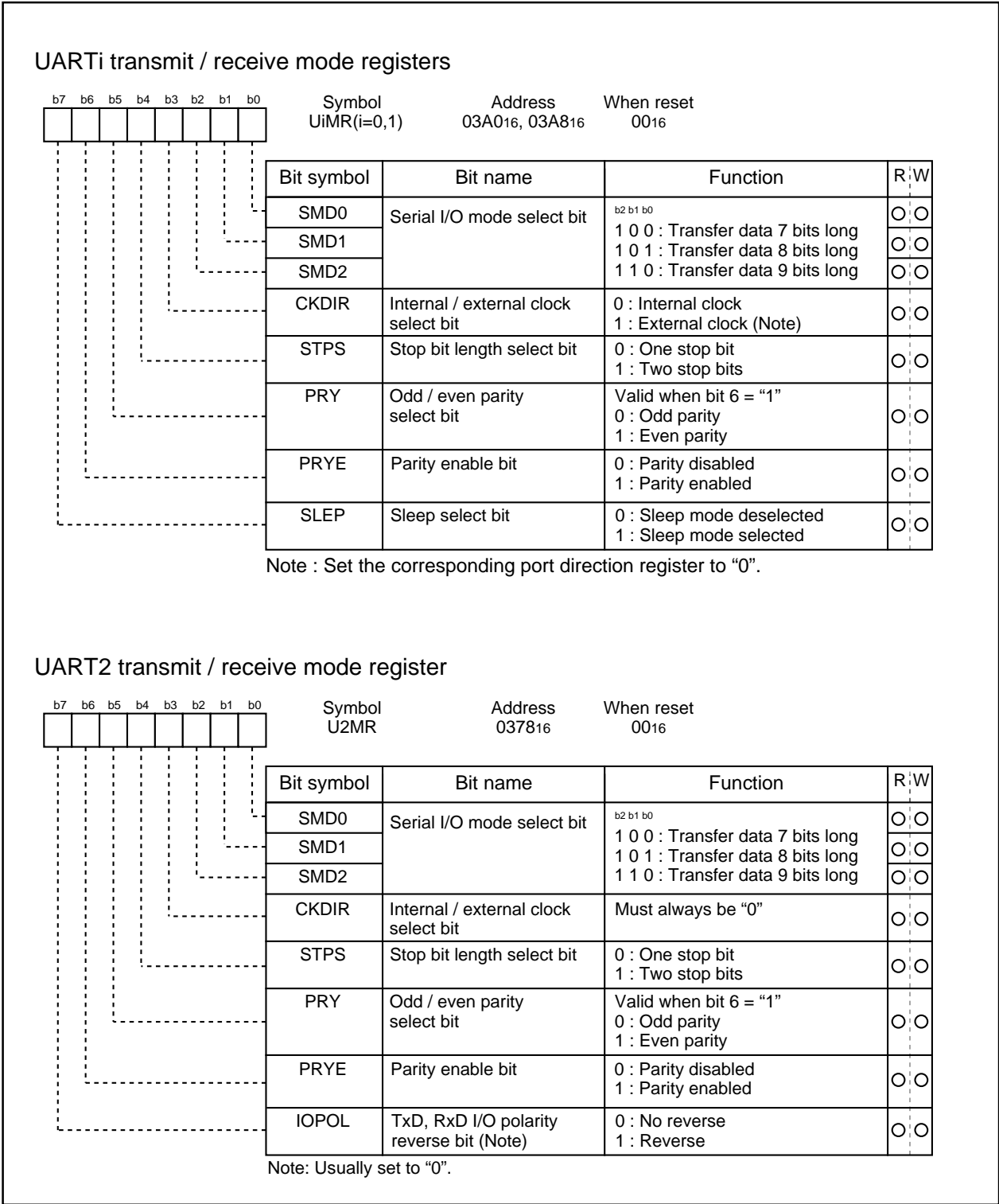

Figure 1.17.16. UARTi transmit/receive mode register in UART mode

Clock asynchronous serial I/O (UART) mode

Table 1.17.7 lists the functions of the input/output pins during UART mode. Note that for a period from when the UARTi operation mode is selected to when transfer starts, the TxDi pin outputs an "H". (If the N-channel open-drain is selected, this pin is in floating state.)

Table 1.17.7. Input/output pin functions in UART mode

Pin name	Function	Method of selection
TxDi (P63, P67, P70)	Serial data output	
RxDi (P62, P66, P71)	Serial data input	Port P62, P66 and P71 direction register (bits 2 and 6 at address 03EE16, bit 1 at address 03EF16) = "0" (Can be used as an input port when performing transmission only)
CLKi (P61, P65, P72)	Programmable I/O port	Internal/external clock select bit (bit 3 at address 03A016, 03A816, 037816) = "0"
	Transfer clock input	Internal/external clock select bit (bit 3 at address 03A016, 03A816) = "1" Port P61, P65 direction register (bits 1 and 5 at address 03EE16) = "0" (Do not set external clock for UART2)
$\overline{\text{CTS}}/\overline{\text{RTS}}_i$ (P60, P64, P73)	$\overline{\text{CTS}}$ input	$\overline{\text{CTS}}/\overline{\text{RTS}}$ disable bit (bit 4 at address 03A416, 03AC16, 037C16) = "0" $\overline{\text{CTS}}/\overline{\text{RTS}}$ function select bit (bit 2 at address 03A416, 03AC16, 037C16) = "0" Port P60, P64 and P73 direction register (bits 0 and 4 at address 03EE16, bit 3 at address 03EF16) = "0"
	RTS output	$\overline{\text{CTS}}/\overline{\text{RTS}}$ disable bit (bit 4 at address 03A416, 03AC16, 037C16) = "0" $\overline{\text{CTS}}/\overline{\text{RTS}}$ function select bit (bit 2 at address 03A416, 03AC16, 037C16) = "1"
	Programmable I/O port	$\overline{\text{CTS}}/\overline{\text{RTS}}$ disable bit (bit 4 at address 03A416, 03AC16, 037C16) = "1"

• Example of transmit timing when transfer data is 8 bits long (parity enabled, one stop bit)

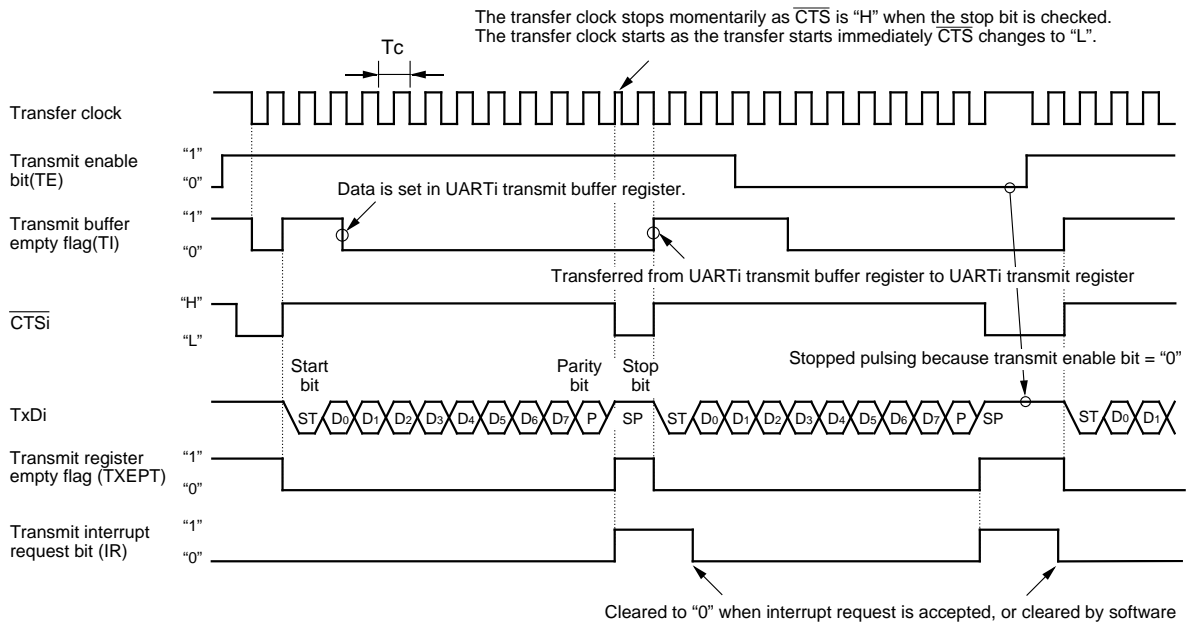

• Example of transmit timing when transfer data is 9 bits long (parity disabled, two stop bits)

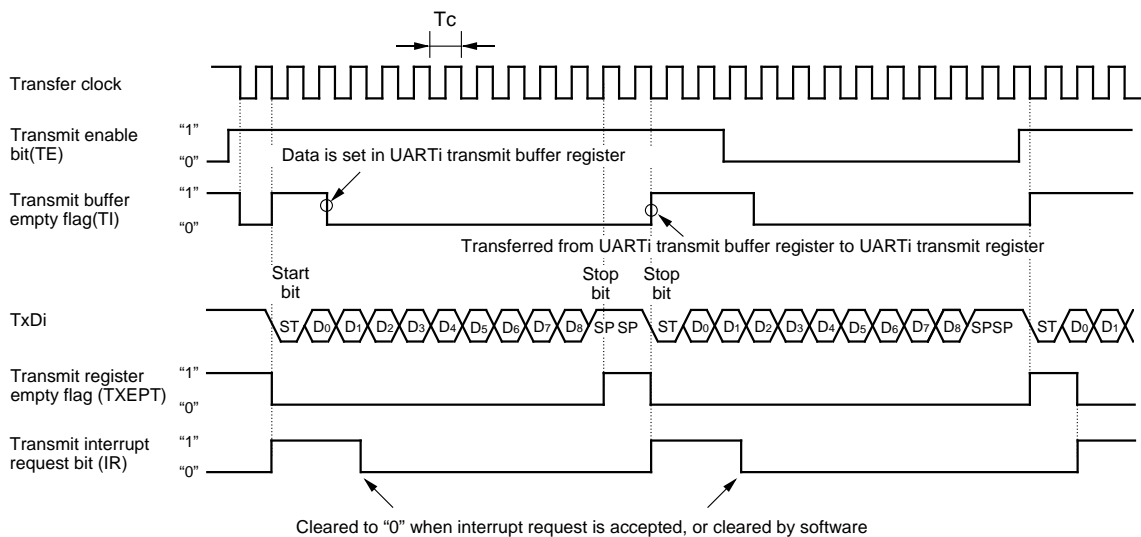

Figure 1.17.17. Typical transmit timings in UART mode(UART0,UART1)

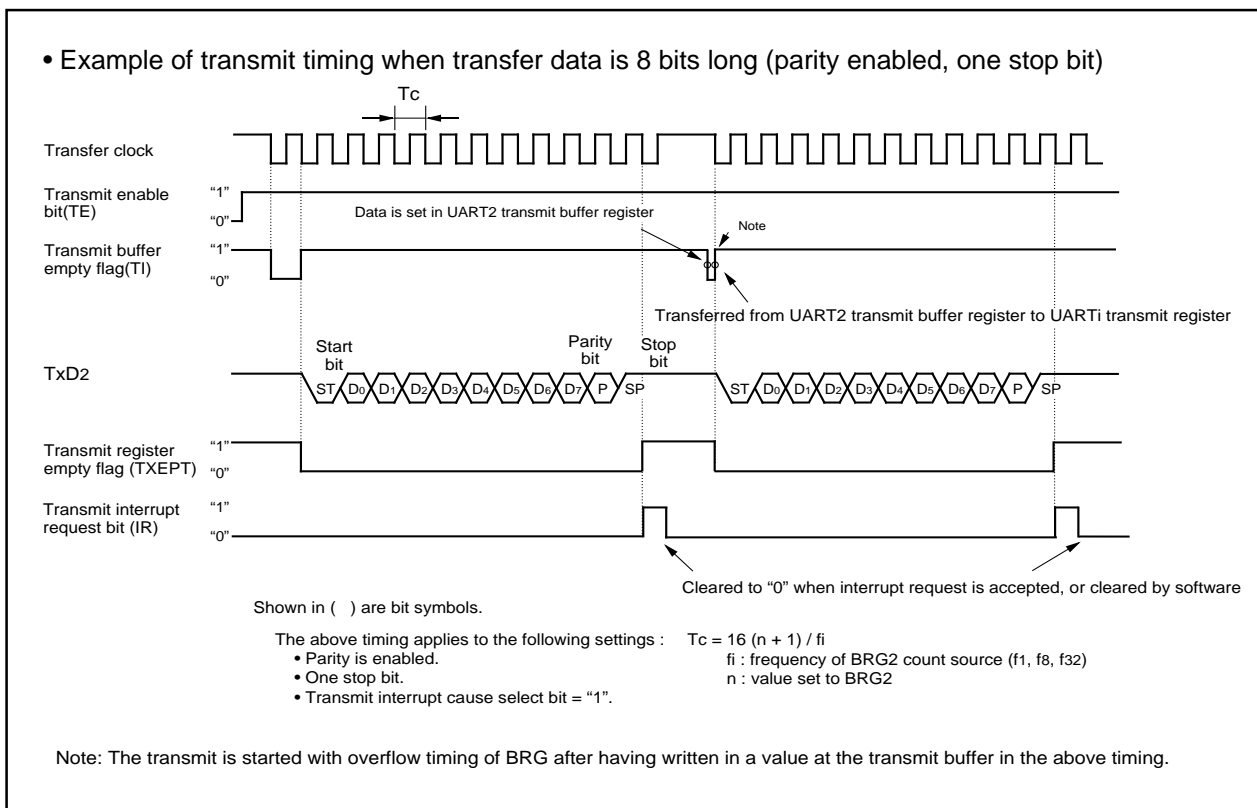

Figure 1.17.18. Typical transmit timings in UART mode(UART2)

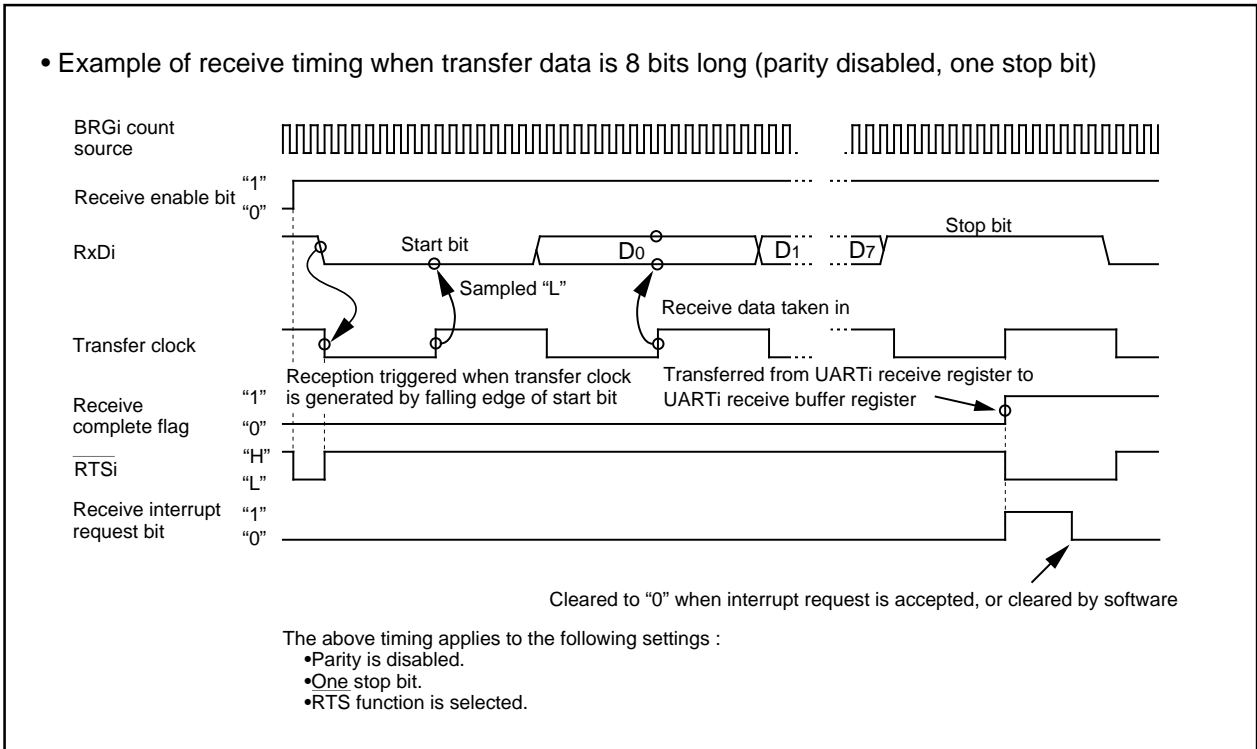

Figure 1.17.19. Typical receive timing in UART mode

(a) Sleep mode (UART0, UART1)

This mode is used to transfer data between specific microcomputers among multiple microcomputers connected using UARTi. The sleep mode is selected when the sleep select bit (bit 7 at addresses 03A016, 03A816) is set to "1" during reception. In this mode, the unit performs receive operation when the MSB of the received data = "1" and does not perform receive operation when the MSB = "0".

(b) Function for switching serial data logic (UART2)

When the data logic select bit (bit 6 of address 037D16) is assigned 1, data is inverted in writing to the transmission buffer register or reading the reception buffer register. Figure 1.17.20 shows the example of timing for switching serial data logic.

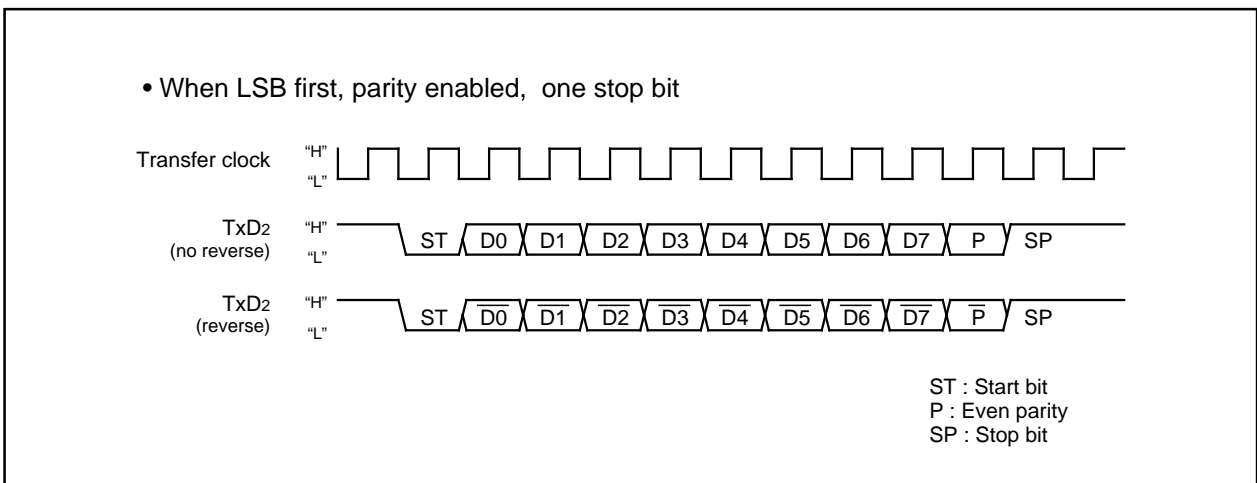

Figure 1.17.20. Timing for switching serial data logic

(c) TxD, RxD I/O polarity reverse function (UART2)

This function is to reverse TxD pin output and RxD pin input. The level of any data to be input or output (including the start bit, stop bit(s), and parity bit) is reversed. Set this function to “0” (not to reverse) for usual use.

(d) Bus collision detection function (UART2)

This function is to sample the output level of the TxD pin and the input level of the RxD pin at the rising edge of the transfer clock; if their values are different, then an interrupt request occurs. Figure 1.17.21 shows the example of detection timing of a bus collision (in UART mode).

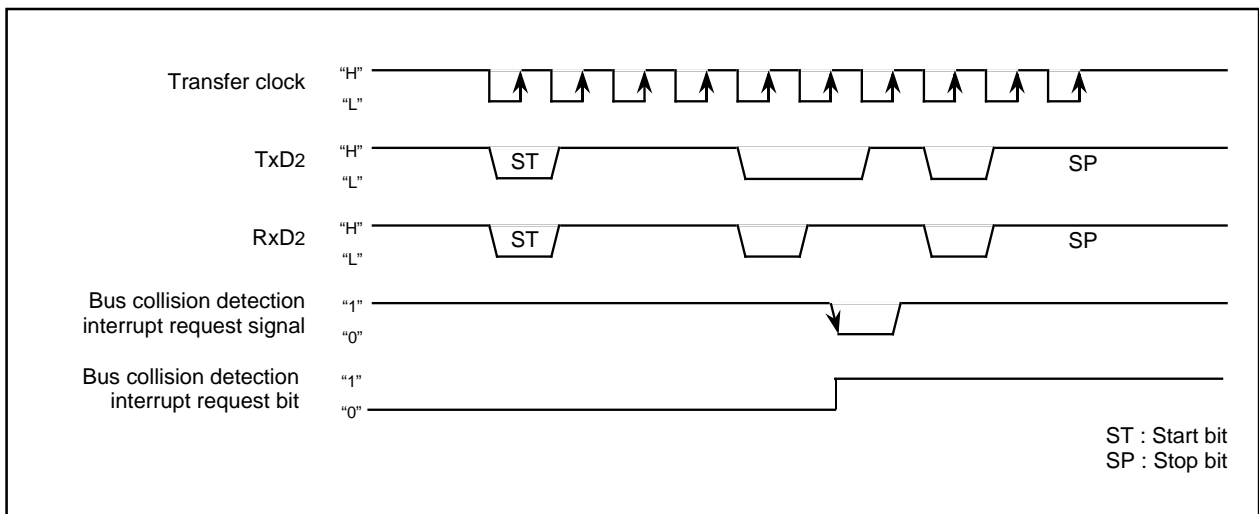

Figure 1.17.21. Detection timing of a bus collision (in UART mode)

(3) Clock-asynchronous serial I/O mode (used for the SIM interface)

The SIM interface is used for connecting the microcomputer with a memory card or the like; adding some extra settings in UART2 clock-asynchronous serial I/O mode allows the user to effect this function. Table 1.17.8 shows the specifications of clock-asynchronous serial I/O mode (used for the SIM interface).

Table 1.17.8. Specifications of clock-asynchronous serial I/O mode (used for the SIM interface)

Item	Specification
Transfer data format	<ul style="list-style-type: none"> • Transfer data 8-bit UART mode (bit 2 through bit 0 of address 0378₁₆ = "1012") • One stop bit (bit 4 of address 0378₁₆ = "0") • With the direct format chosen <ul style="list-style-type: none"> Set parity to "even" (bit 5 and bit 6 of address 0378₁₆ = "1" and "1" respectively) Set data logic to "direct" (bit 6 of address 037D₁₆ = "0"). Set transfer format to LSB (bit 7 of address 037C₁₆ = "0"). • With the inverse format chosen <ul style="list-style-type: none"> Set parity to "odd" (bit 5 and bit 6 of address 0378₁₆ = "0" and "1" respectively) Set data logic to "inverse" (bit 6 of address 037D₁₆ = "1") Set transfer format to MSB (bit 7 of address 037C₁₆ = "1")
Transfer clock	<ul style="list-style-type: none"> • With the internal clock chosen (bit 3 of address 0378₁₆ = "0") : $f_i / 16 (n + 1)$ (Note 1) : $f_i = f_1, f_8, f_{32}$ (Do not set external clock)
Transmission / reception control	<ul style="list-style-type: none"> • Disable the $\overline{\text{CTS}}$ and $\overline{\text{RTS}}$ function (bit 4 of address 037C₁₆ = "1")
Other settings	<ul style="list-style-type: none"> • The sleep mode select function is not available for UART2 • Set transmission interrupt factor to "transmission completed" (bit 4 of address 037D₁₆ = "1")
Transmission start condition	<ul style="list-style-type: none"> • To start transmission, the following requirements must be met: <ul style="list-style-type: none"> - Transmit enable bit (bit 0 of address 037D₁₆) = "1" - Transmit buffer empty flag (bit 1 of address 037D₁₆) = "0"
Reception start condition	<ul style="list-style-type: none"> • To start reception, the following requirements must be met: <ul style="list-style-type: none"> - Reception enable bit (bit 2 of address 037D₁₆) = "1" - Detection of a start bit
Interrupt request generation timing	<ul style="list-style-type: none"> • When transmitting <ul style="list-style-type: none"> When data transmission from the UART2 transmit register is completed (bit 4 of address 037D₁₆ = "1") • When receiving <ul style="list-style-type: none"> When data transfer from the UART2 receive register to the UART2 receive buffer register is completed
Error detection	<ul style="list-style-type: none"> • Overrun error (see the specifications of clock-asynchronous serial I/O) (Note 2) • Framing error (see the specifications of clock-asynchronous serial I/O) • Parity error (see the specifications of clock-asynchronous serial I/O) <ul style="list-style-type: none"> - On the reception side, an "L" level is output from the TxD₂ pin by use of the parity error signal output function (bit 7 of address 037D₁₆ = "1") when a parity error is detected - On the transmission side, a parity error is detected by the level of input to the RxD₂ pin when a transmission interrupt occurs • The error sum flag (see the specifications of clock-asynchronous serial I/O)

Note 1: 'n' denotes the value 00₁₆ to FF₁₆ that is set to the UART2 bit rate generator.

Note 2: If an overrun error occurs, the UART2 receive buffer will have the next data written in. Note also that the UART2 receive interrupt request bit does not change.

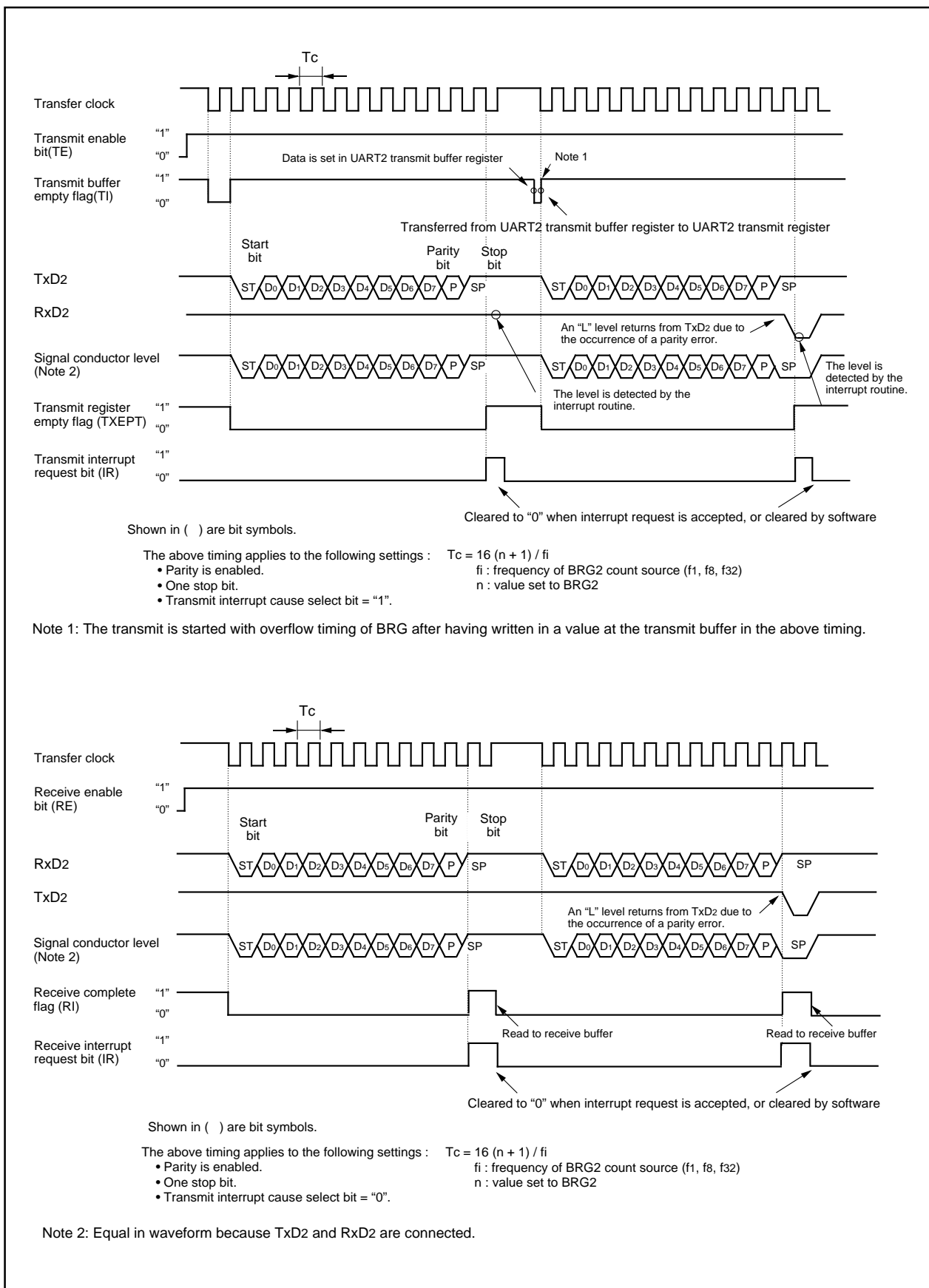

Figure 1.17.22. Typical transmit/receive timing in UART mode (used for the SIM interface)

(a) Function for outputting a parity error signal

During reception, with the error signal output enable bit (bit 7 of address 037D16) assigned "1", you can output an "L" level from the TxD2 pin when a parity error is detected. And during transmission, comparing with the case in which the error signal output enable bit (bit 7 of address 037D16) is assigned "0", the transmission completion interrupt occurs in the half cycle later of the transfer clock. Therefore parity error signals can be detected by a transmission completion interrupt program. Figure 1.17.23 shows the output timing of the parity error signal.

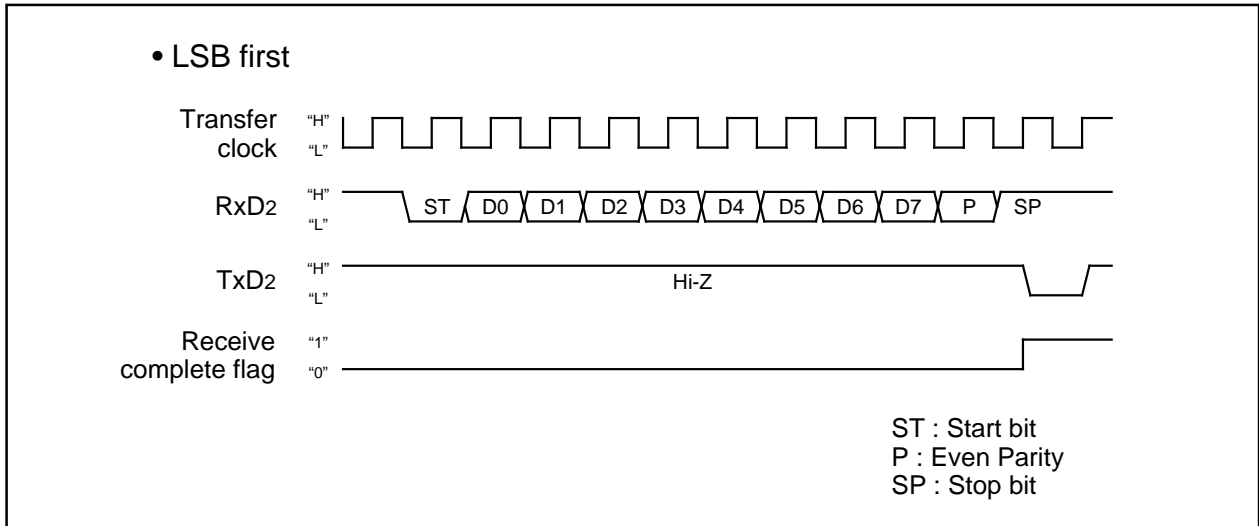

Figure 1.17.23. Output timing of the parity error signal

(b) Direct format/inverse format

Connecting the SIM card allows you to switch between direct format and inverse format. If you choose the direct format, D0 data is output from TxD2. If you choose the inverse format, D7 data is inverted and output from TxD2.

Figure 1.17.24 shows the SIM interface format.

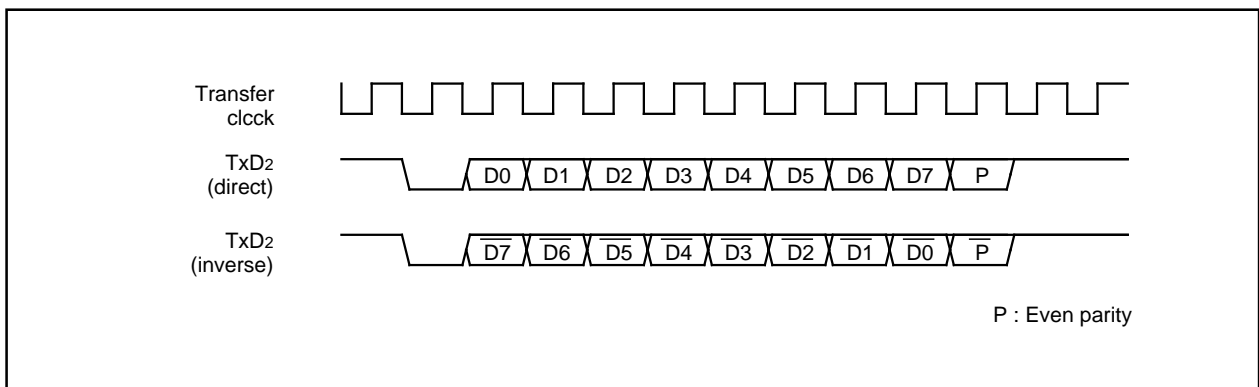

Figure 1.17.24. SIM interface format

Figure 1.17.25 shows the example of connecting the SIM interface. Connect TxD2 and RxD2 and apply pull-up.

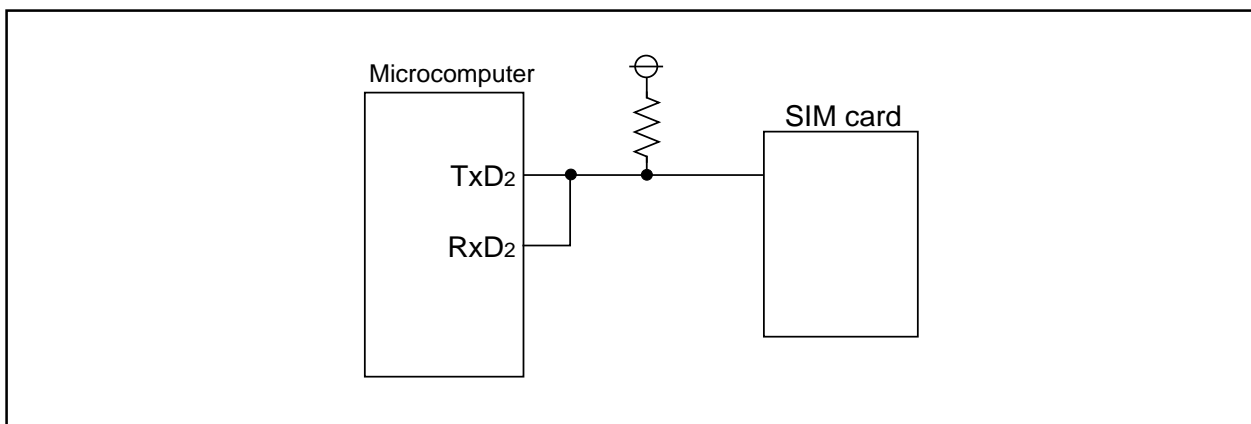

Figure 1.17.25. Connecting the SIM interface

UART2 Special Mode Register

The UART2 special mode register (address 037716) is used to control UART2 in various ways.

Figure 1.17.26 shows the UART2 special mode register.

Bit 0 of the UART2 special mode register (037716) is used as the I²C mode select bit.

Setting “1” in the I²C mode select bit (bit 0) goes the circuit to achieve the I²C bus (simplified I²C bus) interface effective.

Table 1.17.9 shows the relation between the I²C mode select bit and respective control workings.

Since this function uses clock-synchronous serial I/O mode, set this bit to “0” in UART mode.

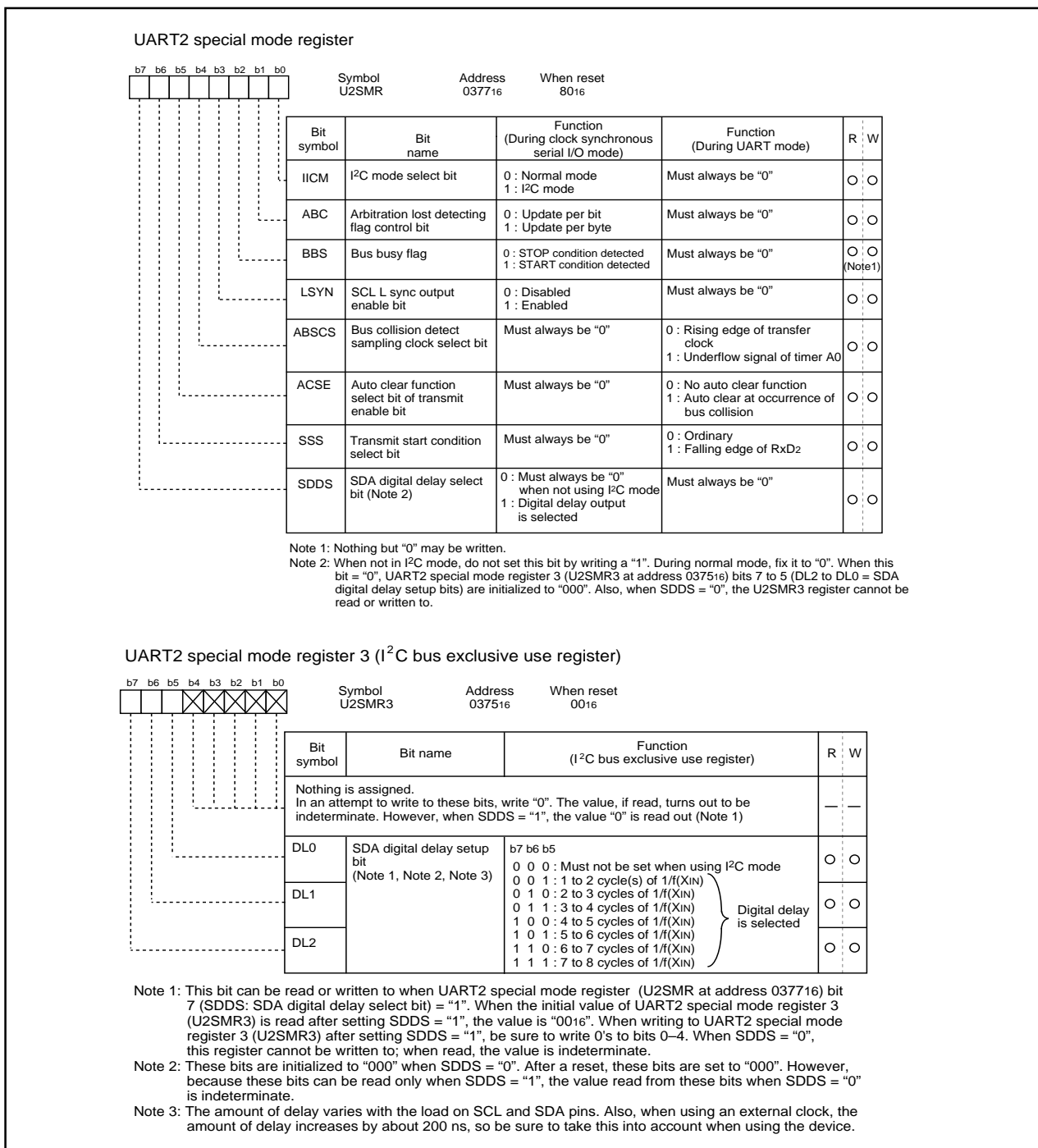

Figure 1.17.26. UART2 special mode register

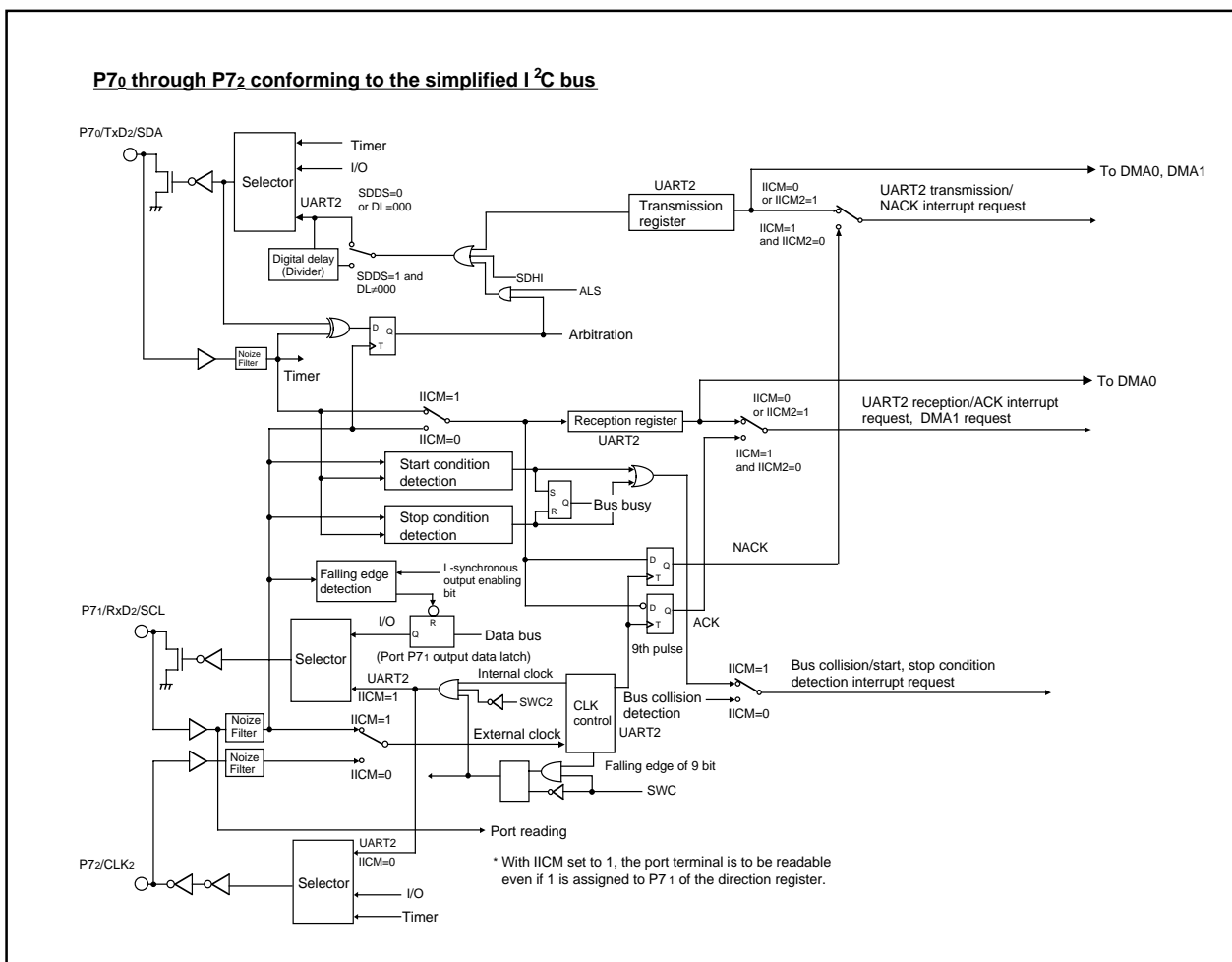

Figure 1.17.27. Functional block diagram for I²C mode

Table 1.17.9. Features in I²C mode

	Function	Normal mode	I ² C mode (Note 1)
1	Factor of interrupt number 10 (Note 2)	Bus collision detection	Start condition detection or stop condition detection
2	Factor of interrupt number 15 (Note 2)	UART2 transmission	No acknowledgment detection (NACK)
3	Factor of interrupt number 16 (Note 2)	UART2 reception	Acknowledgment detection (ACK)
4	UART2 transmission output delay	Not delayed	Delayed (digital delay)
5	P7 ₀ at the time when UART2 is in use	TxD ₂ (output)	SDA (input/output) (Note 3)
6	P7 ₁ at the time when UART2 is in use	RxD ₂ (input)	SCL (input/output)
7	P7 ₂ at the time when UART2 is in use	CLK ₂	P7 ₂
8	DMA1 factor at the time when 1 1 0 1 is assigned to the DMA request factor selection bits	UART2 reception	Acknowledgment detection (ACK)
9	Noise filter width	15ns	200ns
10	Reading P7 ₁	Reading the terminal when 0 is assigned to the direction register	Reading the terminal regardless of the value of the direction register
11	Initial value of UART2 output	H level (when 0 is assigned to the CLK polarity select bit)	The value set in latch P7 ₀ when the port is selected

Note 1: Make the settings given below when I²C mode is in use.
Set 0 1 0 in bits 2, 1, 0 of the UART2 transmission/reception mode register.
Disable the RTS/CTS function. Choose the MSB First function.

Note 2: Follow the steps given below to switch from a factor to another.

1. Disable the interrupt of the corresponding number.
2. Switch from a factor to another.
3. Reset the interrupt request flag of the corresponding number.
4. Set an interrupt level of the corresponding number.

Note 3: Set an initial value of SDA transmission output when serial I/O is invalid.

Figure 1.17.27 shows the functional block diagram for I²C mode. Setting “1” in the I²C mode select bit (IICM) causes ports P70, P71, and P72 to work as data transmission-reception terminal SDA, clock input-output terminal SCL, and port P72 respectively. A delay circuit is added to the SDA transmission output, so the SDA output changes after SCL fully goes to “L”. When digital delay is selected, the amount of delay can be selected in the range of 2 cycles to 8 cycles of f1 using UART2 special mode register 3 (at address 037516). Delay circuit select conditions are shown in Table 1.17.10.

Table 1.17.10. Delay circuit select conditions

	Register value			Contents
	IICM	SDDS	DL	
Digital delay is selected	1	1	001 to 111	Digital delay is added
No delay	0	0	(000)	When IICM = “0”, no delay circuit is selected. When IICM = “0”, however, always make sure SDDS = “0”.

An attempt to read Port P71 (SCL) results in getting the terminal’s level regardless of the content of the port direction register. The initial value of SDA transmission output in this mode goes to the value set in port P70. The interrupt factors of the bus collision detection interrupt, UART2 transmission interrupt, and of UART2 reception interrupt turn to the start/stop condition detection interrupt, acknowledgment non-detection interrupt, and acknowledgment detection interrupt respectively.

The start condition detection interrupt refers to the interrupt that occurs when the falling edge of the SDA terminal (P70) is detected with the SCL terminal (P71) staying “H”. The stop condition detection interrupt refers to the interrupt that occurs when the rising edge of the SDA terminal (P70) is detected with the SCL terminal (P71) staying “H”. The bus busy flag (bit 2 of the UART2 special mode register) is set to “1” by the start condition detection, and set to “0” by the stop condition detection.

The acknowledgment non-detection interrupt refers to the interrupt that occurs when the SDA terminal level is detected still staying “H” at the rising edge of the 9th transmission clock. The acknowledgment detection interrupt refers to the interrupt that occurs when SDA terminal’s level is detected already went to “L” at the 9th transmission clock. Also, assigning 1 1 0 1 (UART2 reception) to the DMA1 request factor select bits provides the means to start up the DMA transfer by the effect of acknowledgment detection. Bit 1 of the UART2 special mode register (037716) is used as the arbitration lost detecting flag control bit. Arbitration means the act of detecting the nonconformity between transmission data and SDA terminal data at the timing of the SCL rising edge. This detecting flag is located at bit 11 of the UART2 reception buffer register (037F16, 037E16), and “1” is set in this flag when nonconformity is detected. Use the arbitration lost detecting flag control bit to choose which way to use to update the flag, bit by bit or byte by byte. When setting this bit to “1” and updated the flag byte by byte if nonconformity is detected, the arbitration lost detecting flag is set to “1” at the falling edge of the 9th transmission clock.

If update the flag byte by byte, must judge and clear (“0”) the arbitration lost detecting flag after completing the first byte acknowledge detect and before starting the next one byte transmission.

Bit 3 of the UART2 special mode register is used as SCL- and L-synchronous output enable bit. Setting this bit to “1” goes the P71 data register to “0” in synchronization with the SCL terminal level going to “L”.

Some other functions added are explained here. Figure 1.17.28 shows their workings.

Bit 4 of the UART2 special mode register is used as the bus collision detect sampling clock select bit. The bus collision detect interrupt occurs when the RxD2 level and TxD2 level do not match, but the nonconformity is detected in synchronization with the rising edge of the transfer clock signal if the bit is set to "0". If this bit is set to "1", the nonconformity is detected at the timing of the overflow of timer A0 rather than at the rising edge of the transfer clock.

Bit 5 of the UART2 special mode register is used as the auto clear function select bit of transmit enable bit. Setting this bit to "1" automatically resets the transmit enable bit to "0" when "1" is set in the bus collision detect interrupt request bit (nonconformity).

Bit 6 of the UART2 special mode register is used as the transmit start condition select bit. Setting this bit to "1" starts the TxD transmission in synchronization with the falling edge of the RxD terminal.

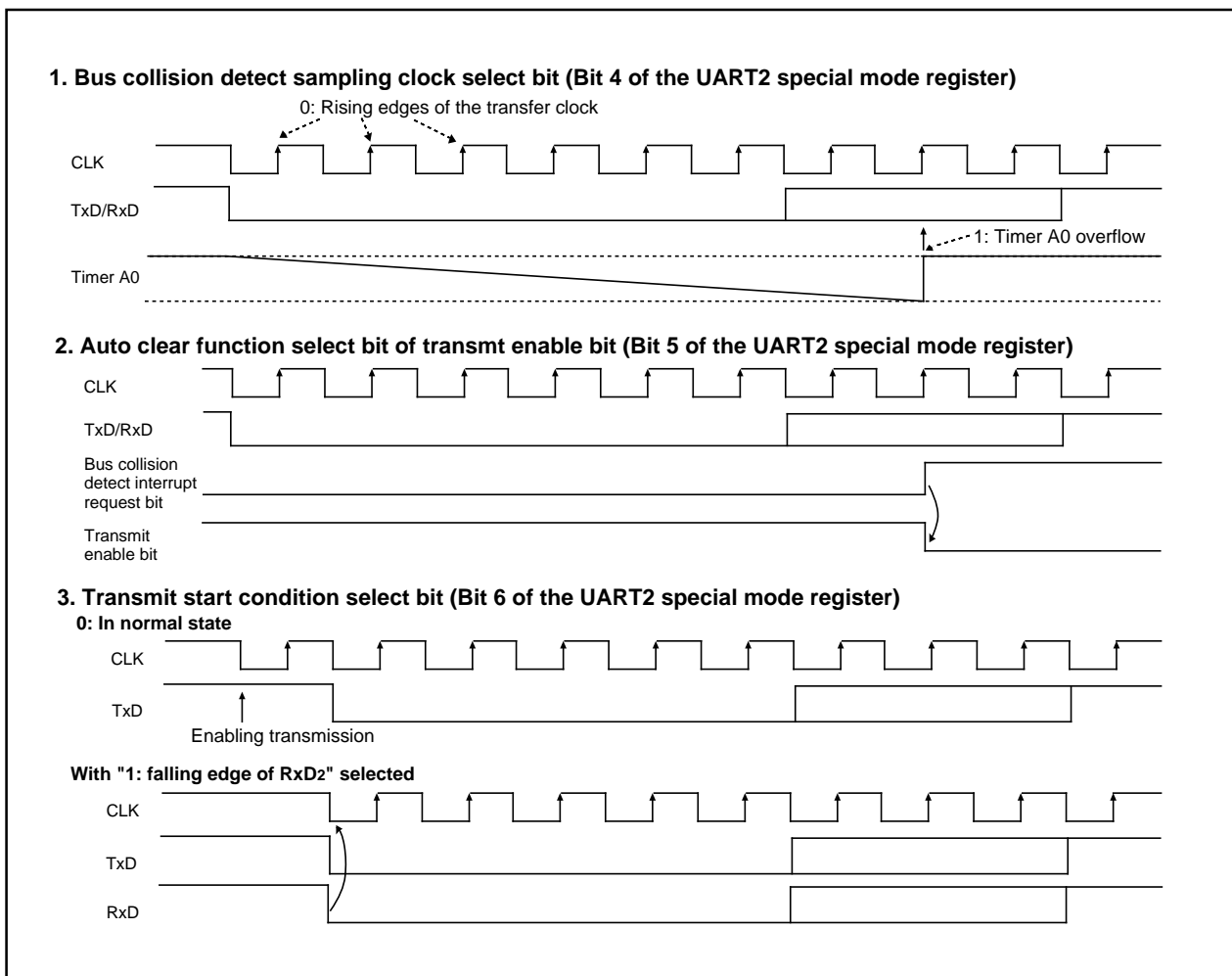

Figure 1.17.28. Some other functions added

UART2 Special Mode Register 2

UART2 special mode register 2 (address 0376₁₆) is used to further control UART2 in I²C mode. Figure 1.17.29 shows the UART2 special mode register 2.

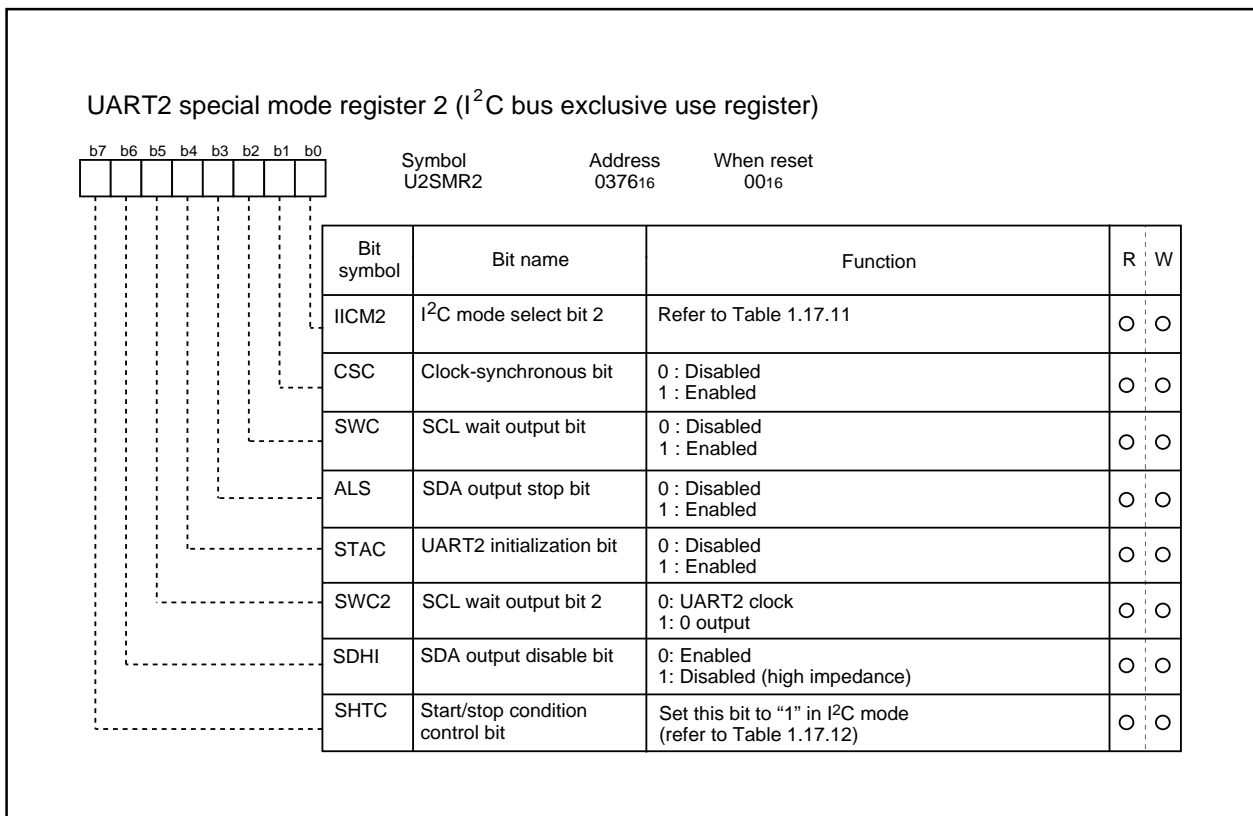

Figure 1.17.29. UART2 special mode register 2

Bit 0 of the UART2 special mode register 2 (address 0376₁₆) is used as the I²C mode select bit 2. Table 1.17.11 shows the types of control to be changed by I²C mode select bit 2 when the I²C mode select bit is set to “1”. Table 1.17.12 shows the timing characteristics of detecting the start condition and the stop condition. Set the start/stop condition control bit (bit 7 of UART2 special mode register 2) to “1” in I²C mode.

Table 1.17.11. Functions changed by I²C mode select bit 2

	Function	IICM2 = 0	IICM2 = 1
1	Factor of interrupt number 15	No acknowledgment detection (NACK)	UART2 transmission (the rising edge of the final bit of the clock)
2	Factor of interrupt number 16	Acknowledgment detection (ACK)	UART2 reception (the falling edge of the final bit of the clock)
3	DMA1 factor at the time when 1 1 0 1 is assigned to the DMA request factor selection bits	Acknowledgment detection (ACK)	UART2 reception (the falling edge of the final bit of the clock)
4	Timing for transferring data from the UART2 reception shift register to the reception buffer.	The rising edge of the final bit of the reception clock	The falling edge of the final bit of the reception clock
5	Timing for generating a UART2 reception/ACK interrupt request	The rising edge of the final bit of the reception clock	The falling edge of the final bit of the reception clock

Table 1.17.12. Timing characteristics of detecting the start condition and the stop condition (Note 1)

3 to 6 cycles < duration for setting-up (Note 2)
3 to 6 cycles < duration for holding (Note 2)

Note 1 : When the start/stop condition control bit SHTC is “1” .

Note 2 : “Cycles” is in terms of the input oscillation frequency f(XIN) of the main clock.

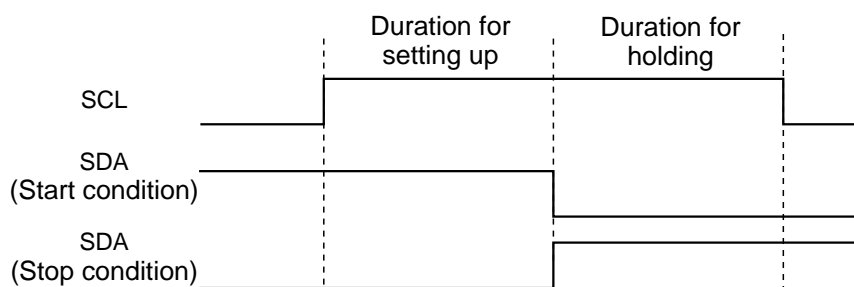

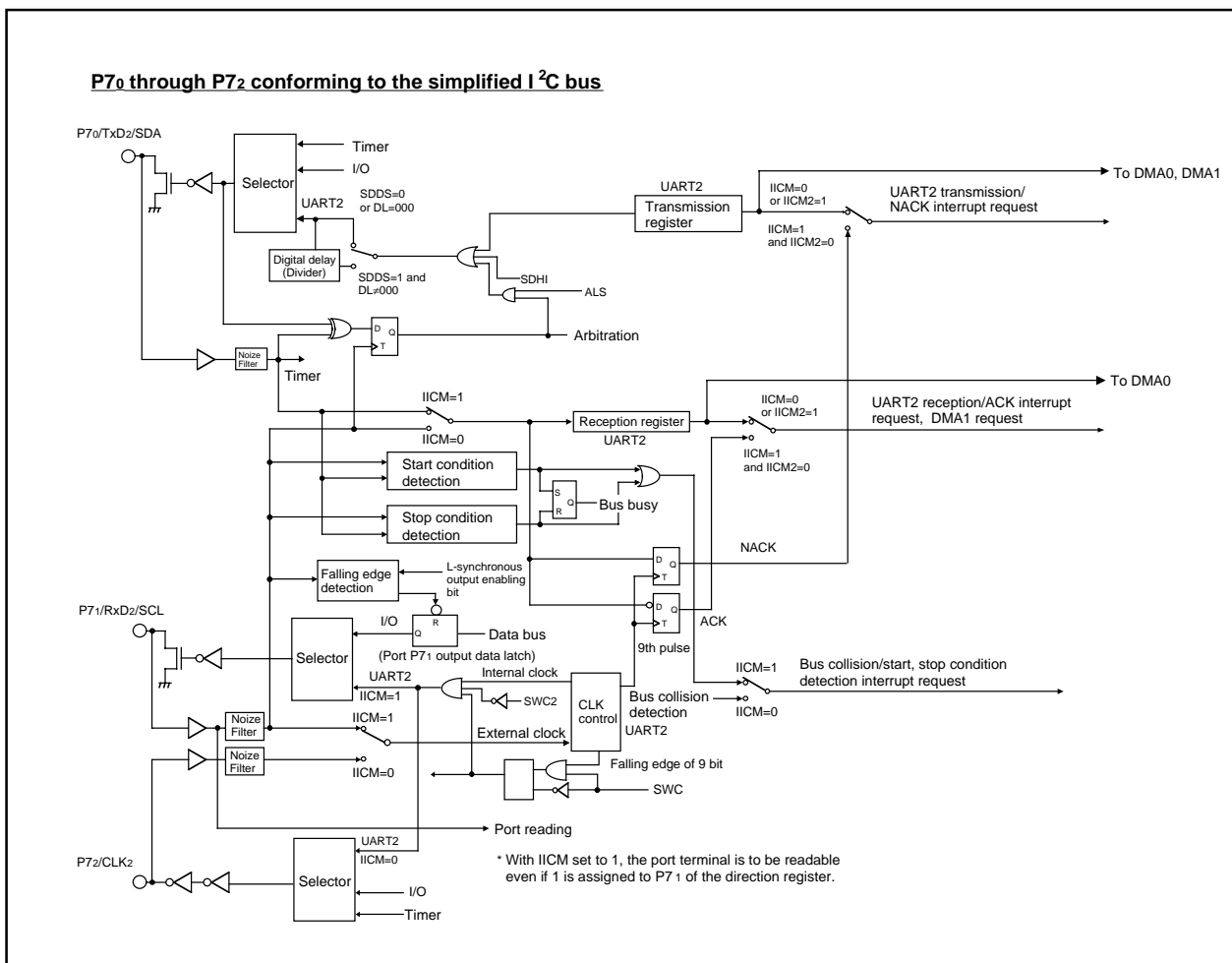

Figure 1.17.30. Functional block diagram for I²C mode

Functions available in I²C mode are shown in Figure 1.17.30 — a functional block diagram.

Bit 3 of the UART2 special mode register 2 (address 037616) is used as the SDA output stop bit. Setting this bit to “1” causes an arbitration loss to occur, and the SDA pin turns to high-impedance state at the instant when the arbitration lost detecting flag is set to “1”.

Bit 1 of the UART2 special mode register 2 (address 037616) is used as the clock synchronization bit. With this bit set to “1” at the time when the internal SCL is set to “H”, the internal SCL turns to “L” if the falling edge is found in the SCL pin; and the baud rate generator reloads the set value, and start counting within the “L” interval. When the internal SCL changes from “L” to “H” with the SCL pin set to “L”, stops counting the baud rate generator, and starts counting it again when the SCL pin turns to “H”. Due to this function, the UART2 transmission-reception clock becomes the logical product of the signal flowing through the internal SCL and that flowing through the SCL pin. This function operates over the period from the moment earlier by a half cycle than falling edge of the UART2 first clock to the rising edge of the ninth bit. To use this function, choose the internal clock for the transfer clock.

Bit 2 of the UART2 special mode register 2 (037616) is used as the SCL wait output bit. Setting this bit to “1” causes the SCL pin to be fixed to “L” at the falling edge of the ninth bit of the clock. Setting this bit to “0” frees the output fixed to “L”.

Bit 4 of the UART2 special mode register 2 (address 0376₁₆) is used as the UART2 initialization bit. Setting this bit to "1", and when the start condition is detected, the microcomputer operates as follows.

- (1) The transmission shift register is initialized, and the content of the transmission register is transferred to the transmission shift register. This starts transmission by dealing with the clock entered next as the first bit. The UART2 output value, however, doesn't change until the first bit data is output after the entrance of the clock, and remains unchanged from the value at the moment when the microcomputer detected the start condition.
- (2) The reception shift register is initialized, and the microcomputer starts reception by dealing with the clock entered next as the first bit.
- (3) The SCL wait output bit turns to "1". This turns the SCL pin to "L" at the falling edge of the ninth bit of the clock.

Starting to transmit/receive signals to/from UART2 using this function doesn't change the value of the transmission buffer empty flag. To use this function, choose the external clock for the transfer clock.

Bit 5 of the UART2 special mode register 2 (0376₁₆) is used as the SCL pin wait output bit 2. Setting this bit to "1" with the serial I/O specified allows the user to forcibly output an "1" from the SCL pin even if UART2 is in operation. Setting this bit to "0" frees the "L" output from the SCL pin, and the UART2 clock is input/output.

Bit 6 of the UART2 special mode register 2 (0376₁₆) is used as the SDA output disable bit. Setting this bit to "1" forces the SDA pin to turn to the high-impedance state. Refrain from changing the value of this bit at the rising edge of the UART2 transfer clock. There can be instances in which arbitration lost detecting flag is turned on.

S I/O3, 4

S I/O3 and S I/O4 are exclusive clock-synchronous serial I/Os.

Figure 1.17.31 shows the S I/O3, 4 block diagram, and Figure 1.17.32 shows the S I/O3, 4 related register. Table 1.17.13 shows the specifications of S I/O3, 4.

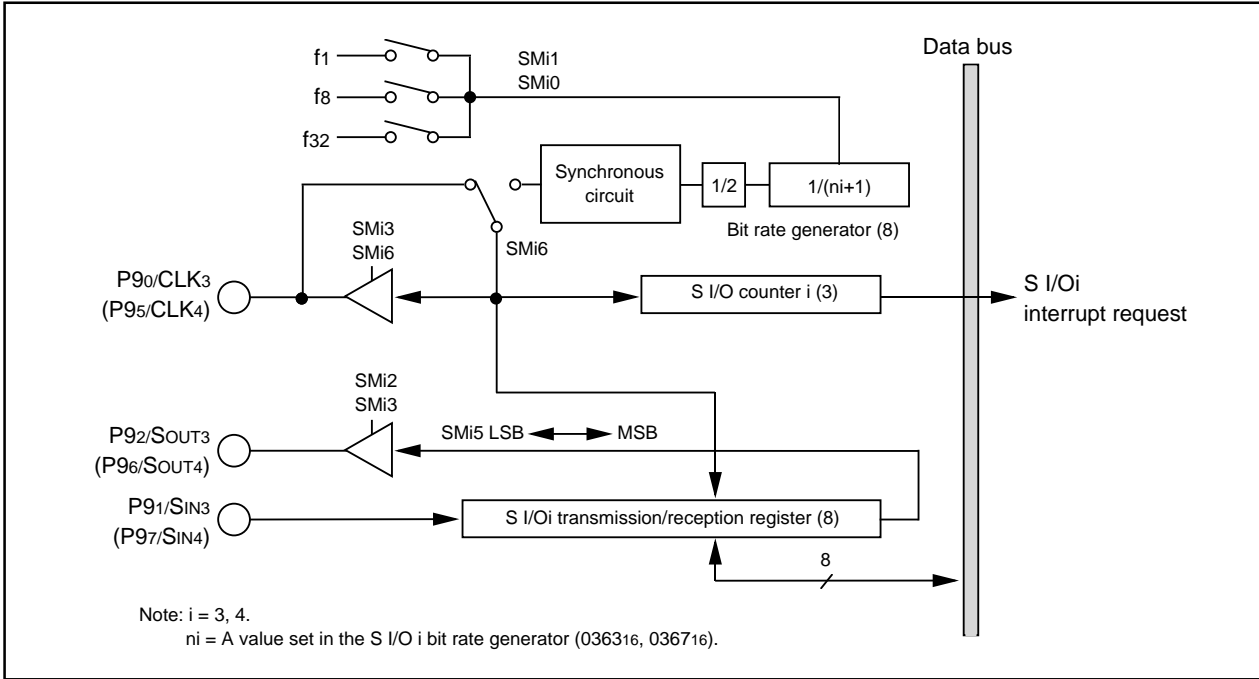

Figure 1.17.31. S I/O3, 4 block diagram

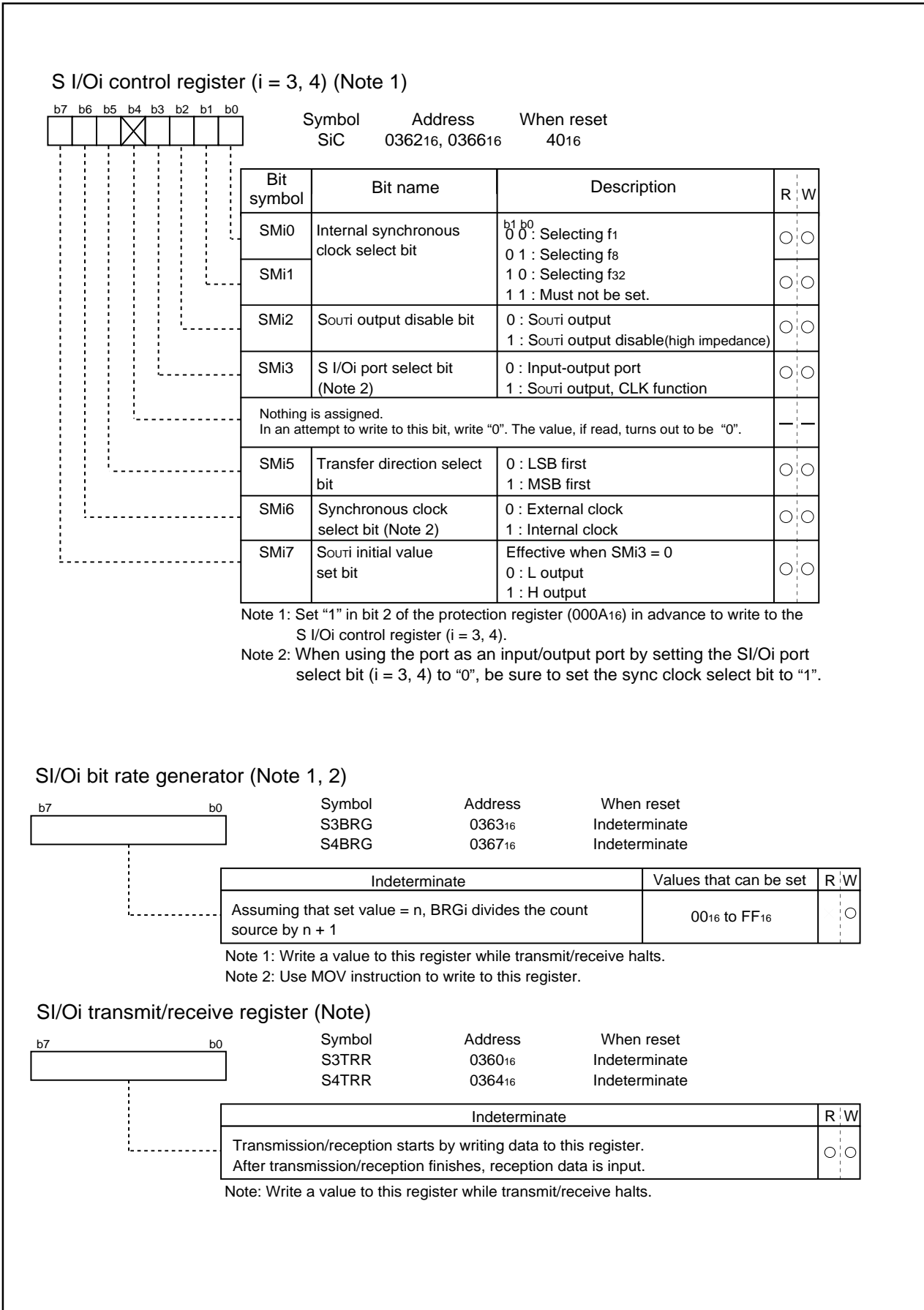

Figure 1.17.32. S I/O3, 4 related register

Table 1.17.13. Specifications of S I/O3, 4

Item	Specifications
Transfer data format	<ul style="list-style-type: none"> • Transfer data length: 8 bits
Transfer clock	<ul style="list-style-type: none"> • With the internal clock selected (bit 6 of 0362₁₆, 0366₁₆ = "1"): $f_1/2(n_i+1)$, $f_8/2(n_i+1)$, $f_{32}/2(n_i+1)$ (Note 1) • With the external clock selected (bit 6 of 0362₁₆, 0366₁₆ = 0): Input from the CLK_i terminal (Note 2)
Conditions for transmission/reception start	<ul style="list-style-type: none"> • To start transmit/reception, the following requirements must be met: <ul style="list-style-type: none"> - Select the synchronous clock (use bit 6 of 0362₁₆, 0366₁₆). Select a frequency dividing ratio if the internal clock has been selected (use bits 0 and 1 of 0362₁₆, 0366₁₆). - SOUT_i initial value set bit (use bit 7 of 0362₁₆, 0366₁₆) = 1. - S I/O_i port select bit (bit 3 of 0362₁₆, 0366₁₆) = 1. - Select the transfer direction (use bit 5 of 0362₁₆, 0366₁₆) - Write transfer data to SI/O_i transmit/receive register (0360₁₆, 0364₁₆) • To use S I/O_i interrupts, the following requirements must be met: <ul style="list-style-type: none"> - Clear the SI/O_i interrupt request bit before writing transfer data to the SI/O_i transmit/receive register (bit 3 of 0049₁₆, 0048₁₆) = 0.
Interrupt request generation timing	<ul style="list-style-type: none"> • Rising edge of the last transfer clock. (Note 3)
Select function	<ul style="list-style-type: none"> • LSB first or MSB first selection Whether transmission/reception begins with bit 0 (LSB) or bit 7 (MSB) can be selected. • Function for setting an SOUT_i initial value selection When using an external clock for the transfer clock, the user can choose the SOUT_i pin output level during a non-transfer time. For details on how to set, see Figure 1.17.33.
Precaution	<ul style="list-style-type: none"> • Unlike UART0–2, SI/O_i (i = 3, 4) is not divided for transfer register and buffer. Therefore, do not write the next transfer data to the SI/O_i transmit/receive register (addresses 0360₁₆, 0364₁₆) during a transfer. • When the internal clock is selected for the transfer clock, SOUT_i holds the last data for a 1/2 transfer clock period after it finished transferring and then goes to a high-impedance state. However, if the transfer data is written to the SI/O_i transmit/receive register (addresses 0360₁₆, 0364₁₆) during this time, SOUT_i is placed in the high-impedance state immediately upon writing and the data hold time is thereby reduced.

Note 1: n is a value from 00₁₆ through FF₁₆ set in the S I/O_i bit rate generator (i = 3, 4).

Note 2: With the external clock selected:

- Before data can be written to the SI/O_i transmit/receive register (addresses 0360₁₆, 0364₁₆), the CLK_i pin input must be in the high state. Also, before rewriting the SI/O_i Control Register (addresses 0362₁₆, 0366₁₆)'s bit 7 (SOUT_i initial value set bit), make sure the CLK_i pin input is held high.
- The S I/O_i circuit keeps on with the shift operation as long as the synchronous clock is entered in it, so stop the synchronous clock at the instant when it counts to eight. The internal clock, if selected, automatically stops.

Note 3: If the internal clock is used for the synchronous clock, the transfer clock signal stops at the "H" state.

■ **Functions for setting an Sout_i initial value**

When using an external clock for the transfer clock, the SOUT_i pin output level during a non-transfer time can be set to the high or the low state. Figure 1.17.33 shows the timing chart for setting an SOUT_i initial value and how to set it.

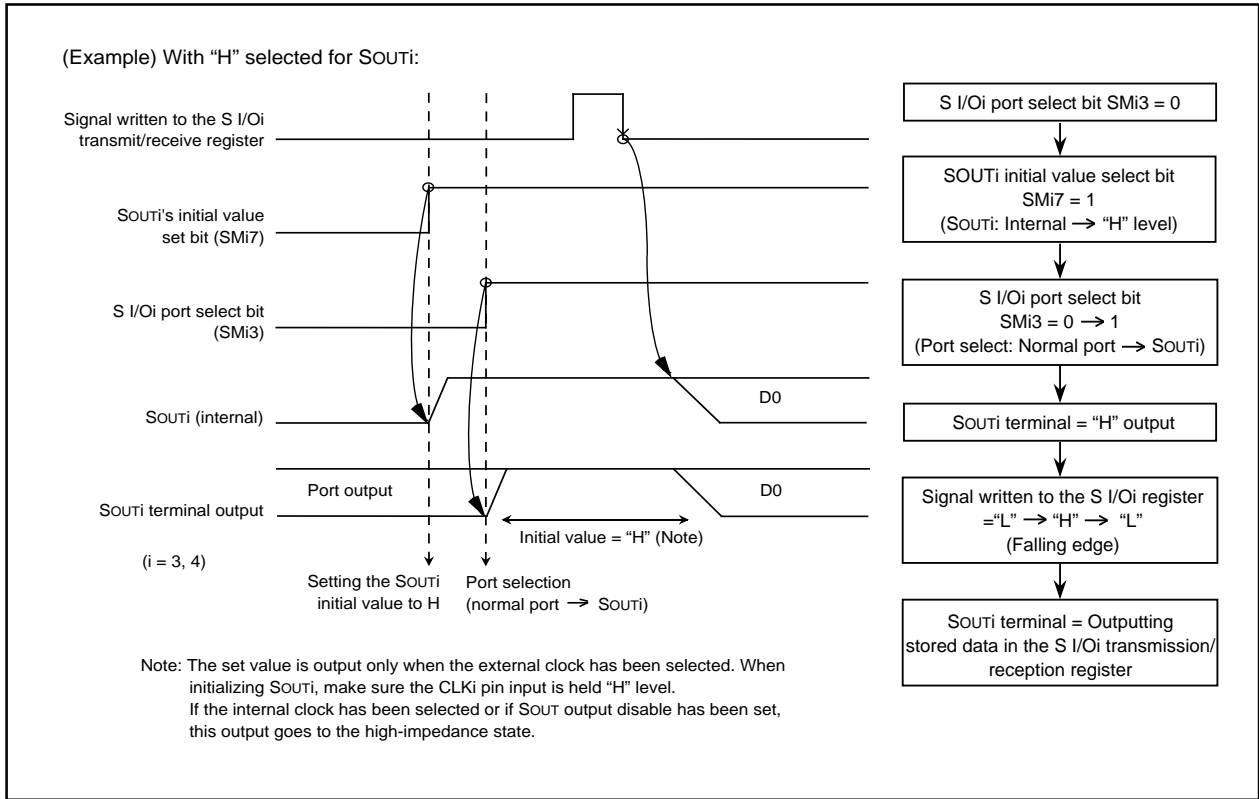

Figure 1.17.33. Timing chart for setting SOUT_i's initial value and how to set it

■ **S I/Oi operation timing**

Figure 1.17.34 shows the S I/Oi operation timing

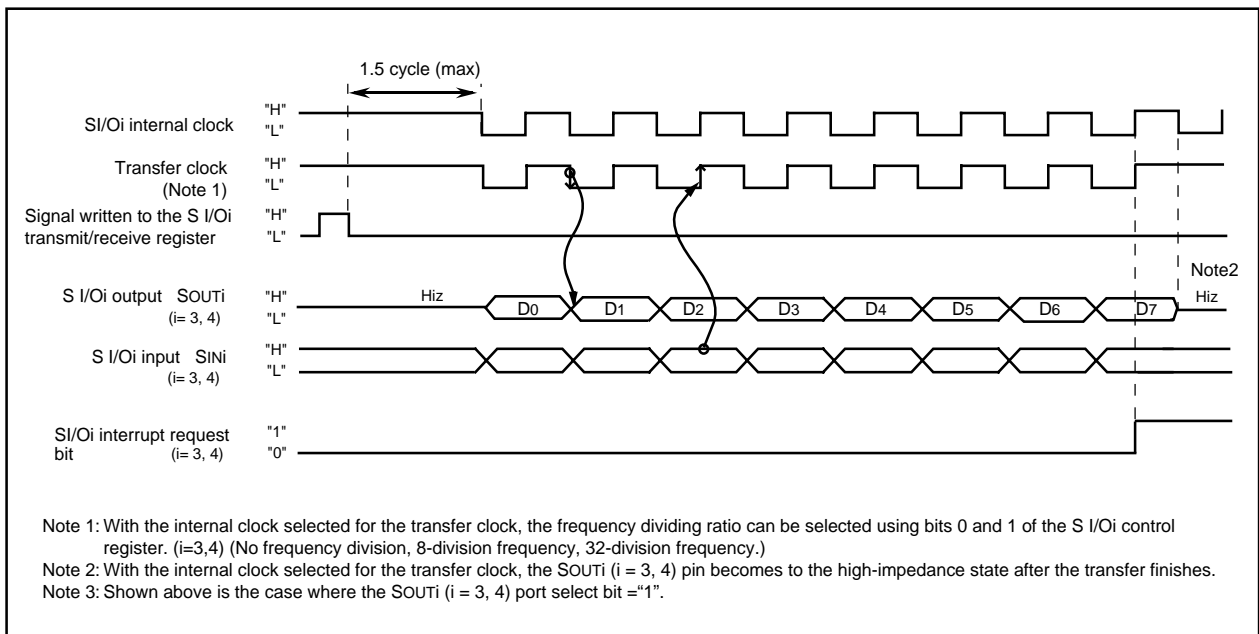

Figure 1.17.34. S I/Oi operation timing chart

A-D Converter

The A-D converter consists of one 10-bit successive approximation A-D converter circuit with a capacitive coupling amplifier. Pins P100 to P107, P95, P96 and P00 to P07 also function as the analog signal input pins. The direction registers of these pins for A-D conversion must therefore be set to input. The Vref connect bit (bit 5 at address 03D716) can be used to isolate the resistance ladder of the A-D converter from the reference voltage input pin (VREF) when the A-D converter is not used. Doing so stops any current flowing into the resistance ladder from VREF, reducing the power dissipation. When using the A-D converter, start A-D conversion only after setting bit 5 of 03D716 to connect VREF.

The result of A-D conversion is stored in the A-D registers of the selected pins. When set to 10-bit precision, the low 8 bits are stored in the even addresses and the high 2 bits in the odd addresses. When set to 8-bit precision, the low 8 bits are stored in the even addresses.

Table 1.18.1 shows the performance of the A-D converter. Figure 1.18.1 shows the block diagram of the A-D converter, and Figures 1.18.2 and 1.18.3 show the A-D converter-related registers.

Table 1.18.1. Performance of A-D converter

Item	Performance
Method of A-D conversion	Successive approximation (capacitive coupling amplifier)
Analog input voltage (Note 1)	0V to AVCC (VCC)
Operating clock ϕ_{AD} (Note 2)	VCC = 3.3V $f_{AD}/\text{divide-by-2}$ of $f_{AD}/\text{divide-by-4}$ of f_{AD} , $f_{AD}=f(XIN)$
Resolution	8-bit or 10-bit (selectable)
Absolute precision	VCC = 3.3V <ul style="list-style-type: none"> • Without sample and hold function $\pm 5\text{LSB}$ • With sample and hold function (8-bit resolution) $\pm 2\text{LSB}$ • With sample and hold function (10-bit resolution) AN0 to AN7 input : $\pm 5\text{LSB}$ ANEX0 and ANEX1 input (including mode in which external operation amp is connected) : $\pm 7\text{LSB}$ AN00 to AN07 input : $\pm 7\text{LSB}$
Operating modes	One-shot mode, repeat mode, single sweep mode, repeat sweep mode 0, and repeat sweep mode 1
Analog input pins	8pins (AN0 to AN7) + 2pins (ANEX0 and ANEX1) + 8pins (AN00 to AN07)
A-D conversion start condition	<ul style="list-style-type: none"> • Software trigger A-D conversion starts when the A-D conversion start flag changes to "1" • External trigger (can be retriggered) A-D conversion starts when the A-D conversion start flag is "1" and the $\overline{ADTRG}/P97$ input changes from "H" to "L"
Conversion speed per pin	<ul style="list-style-type: none"> • Without sample and hold function 8-bit resolution: 49 ϕ_{AD} cycles, 10-bit resolution: 59 ϕ_{AD} cycles • With sample and hold function 8-bit resolution: 28 ϕ_{AD} cycles, 10-bit resolution: 33 ϕ_{AD} cycles

Note 1: Does not depend on use of sample and hold function.

Note 2: Divide the f_{AD} if $f(XIN)$ exceeds 10MHz, and make ϕ_{AD} frequency equal to or less than 10MHz. And divide the f_{AD} if VCC is less than 3.0V, and make ϕ_{AD} frequency equal to or lower than $f_{AD}/2$.

Without sample and hold function, set the ϕ_{AD} frequency to 250kHz min.

With the sample and hold function, set the ϕ_{AD} frequency to 1MHz min.

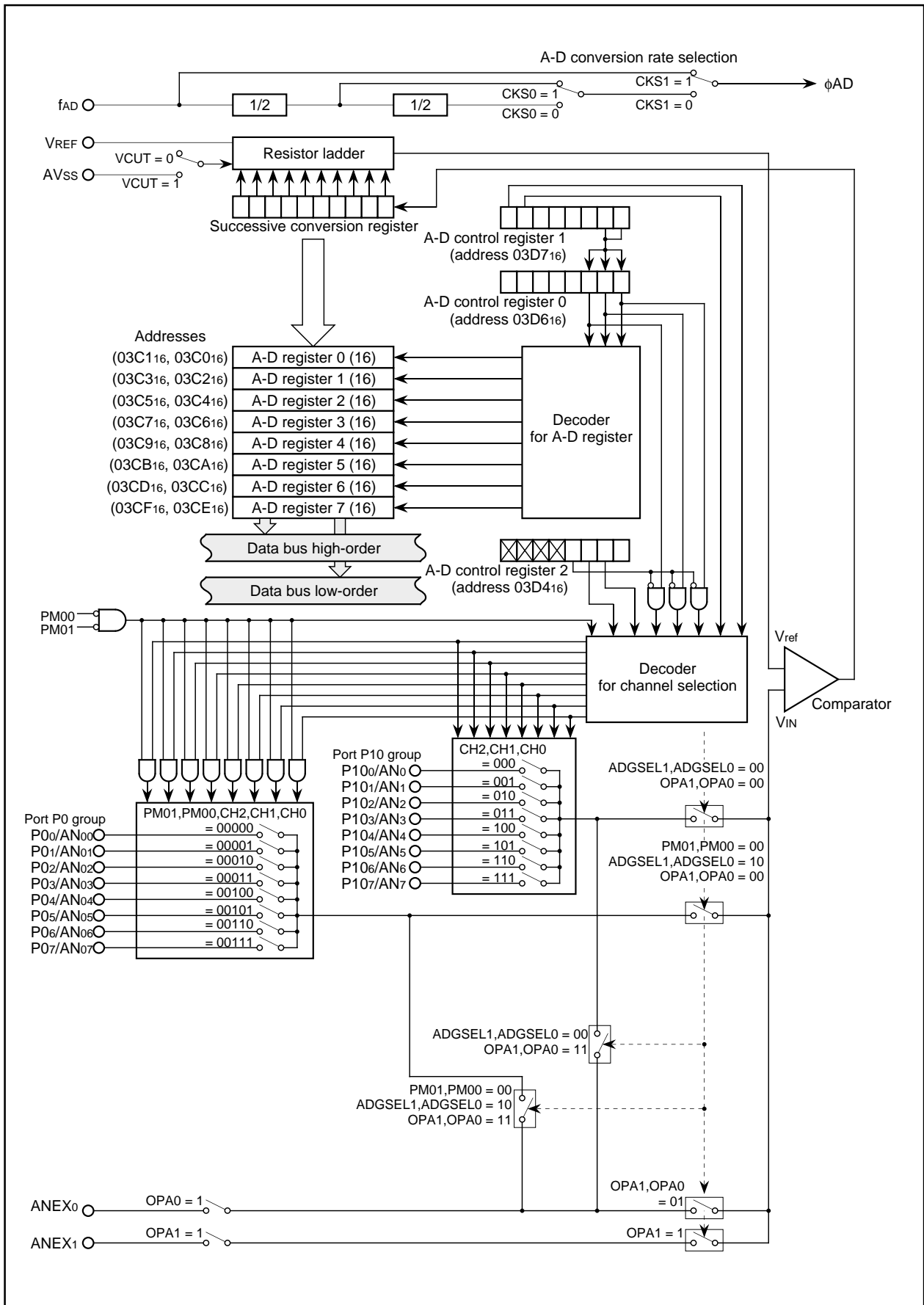

Figure 1.18.1. Block diagram of A-D converter

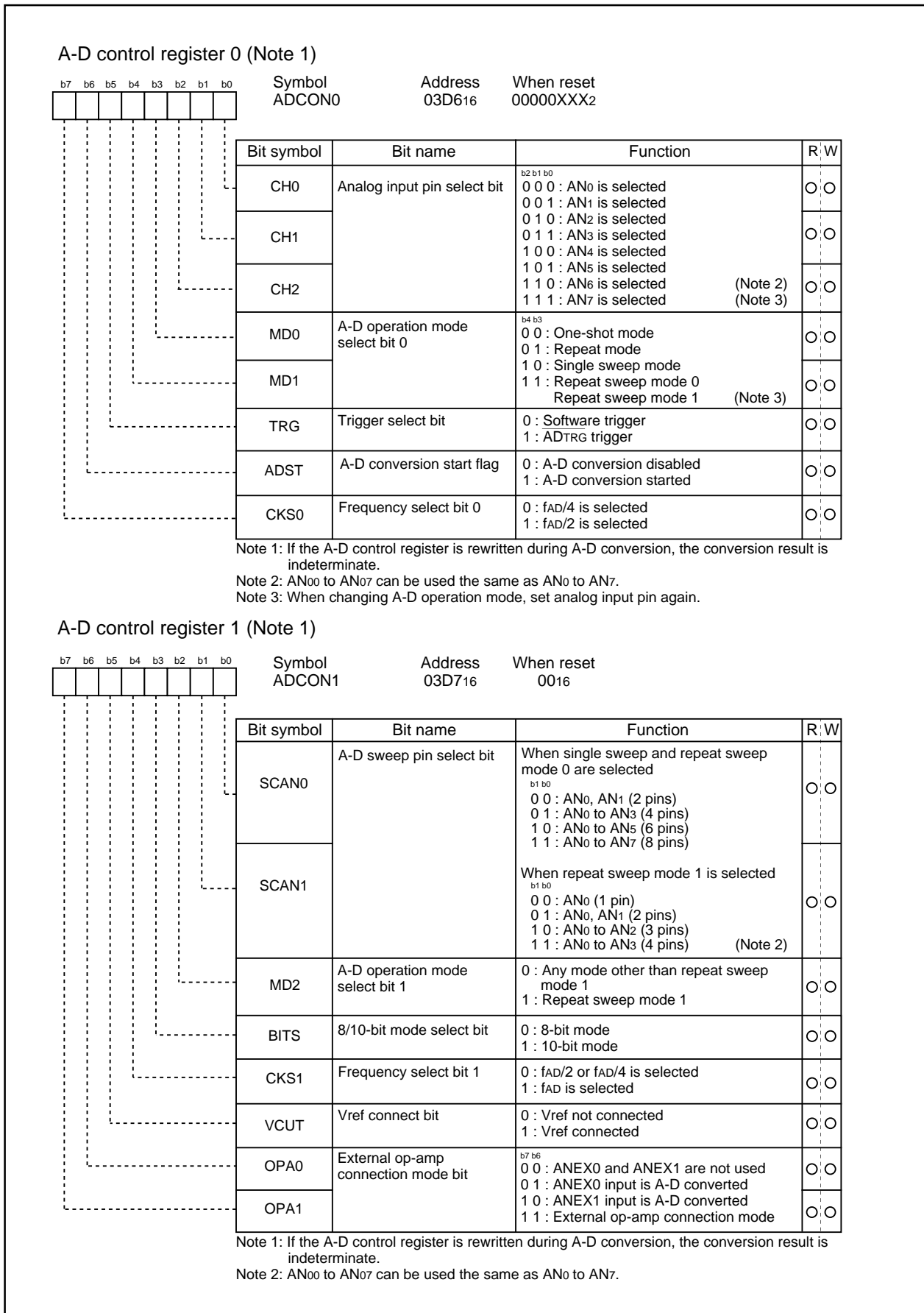

Figure 1.18.2. A-D converter-related registers (1)

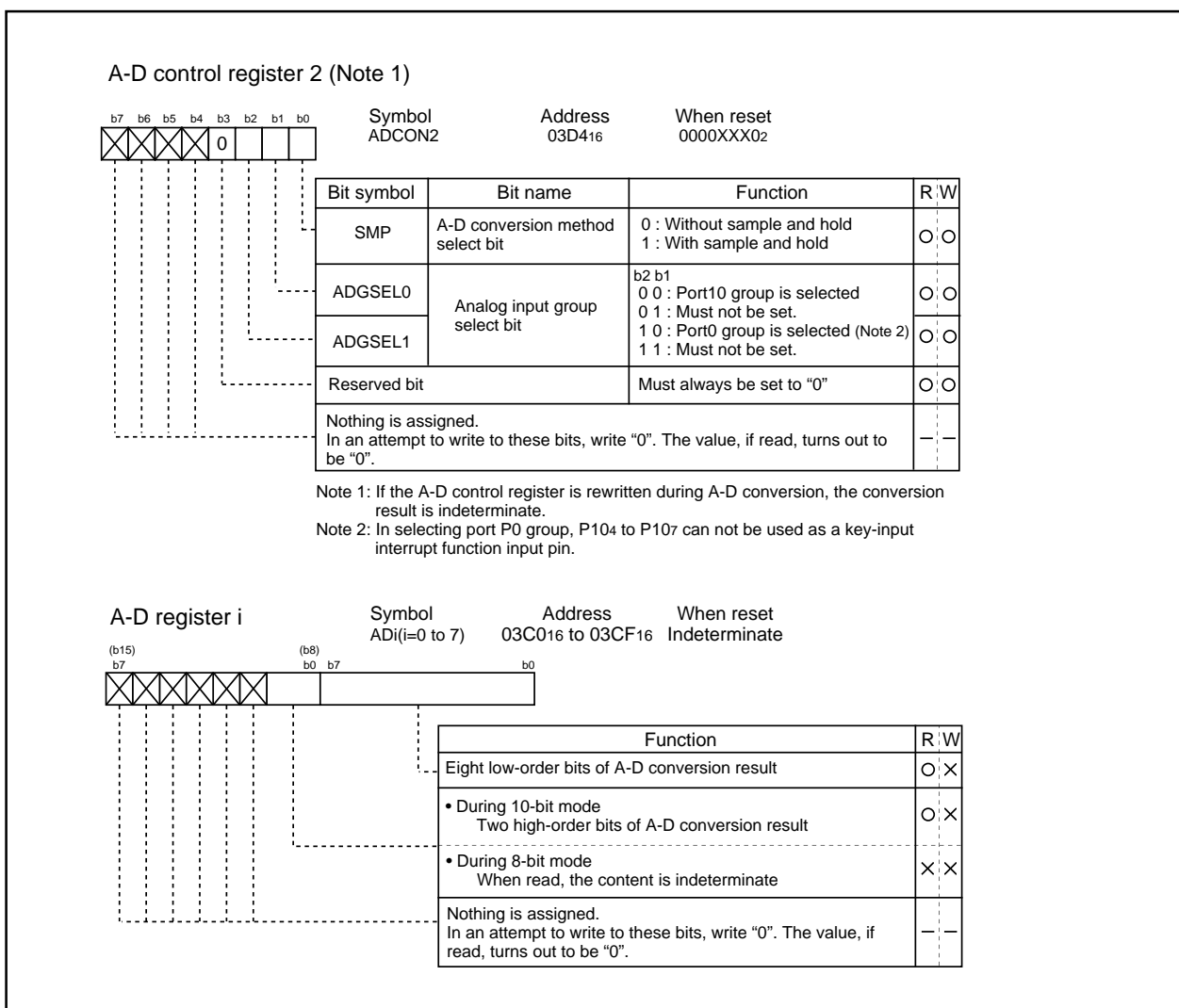

Figure 1.18.3. A-D converter-related registers (2)

(1) One-shot mode

In one-shot mode, the pin selected using the analog input pin select bit is used for one-shot A-D conversion. Table 1.18.2 shows the specifications of one-shot mode. Figure 1.18.4 shows the A-D control register in one-shot mode.

Table 1.18.2. One-shot mode specifications

Item	Specification
Function	The pin selected by the analog input pin select bit is used for one A-D conversion
Start condition	Writing "1" to A-D conversion start flag
Stop condition	<ul style="list-style-type: none"> End of A-D conversion (A-D conversion start flag changes to "0", except when external trigger is selected) Writing "0" to A-D conversion start flag
Interrupt request generation timing	End of A-D conversion
Input pin	One of AN ₀ to AN ₇ , as selected (Note)
Reading of result of A-D converter	Read A-D register corresponding to selected pin

Note : AN₀ to AN₇ can be used the same as AN₀ to AN₇.

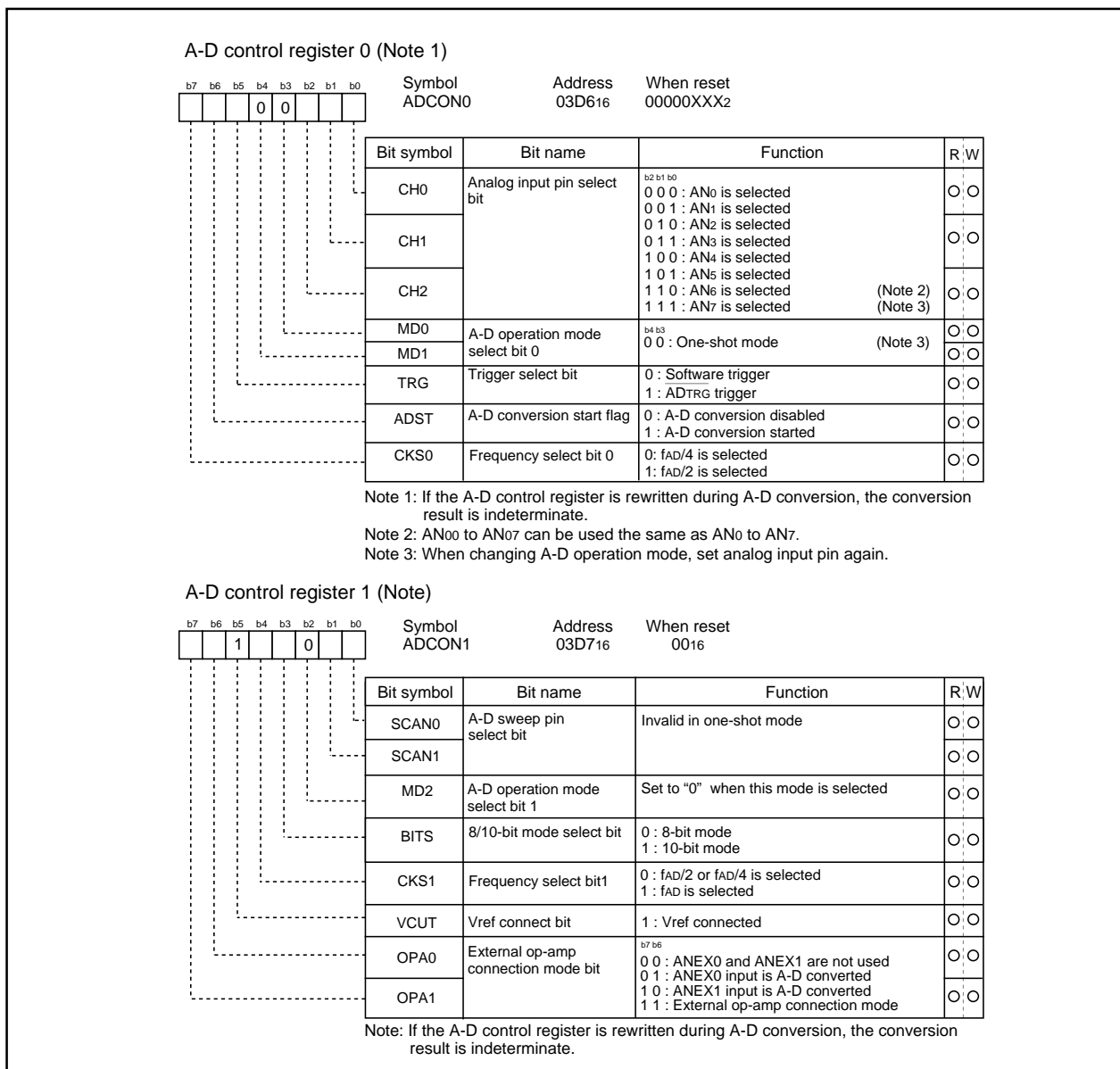

Figure 1.18.4. A-D conversion register in one-shot mode

(2) Repeat mode

In repeat mode, the pin selected using the analog input pin select bit is used for repeated A-D conversion. Table 1.18.3 shows the specifications of repeat mode. Figure 1.18.5 shows the A-D control register in repeat mode.

Table 1.18.3. Repeat mode specifications

Item	Specification
Function	The pin selected by the analog input pin select bit is used for repeated A-D conversion
Star condition	Writing "1" to A-D conversion start flag
Stop condition	Writing "0" to A-D conversion start flag
Interrupt request generation timing	None generated
Input pin	One of AN0 to AN7, as selected (Note)
Reading of result of A-D converter	Read A-D register corresponding to selected pin (at any time)

Note : AN00 to AN07 can be used the same as AN0 to AN7.

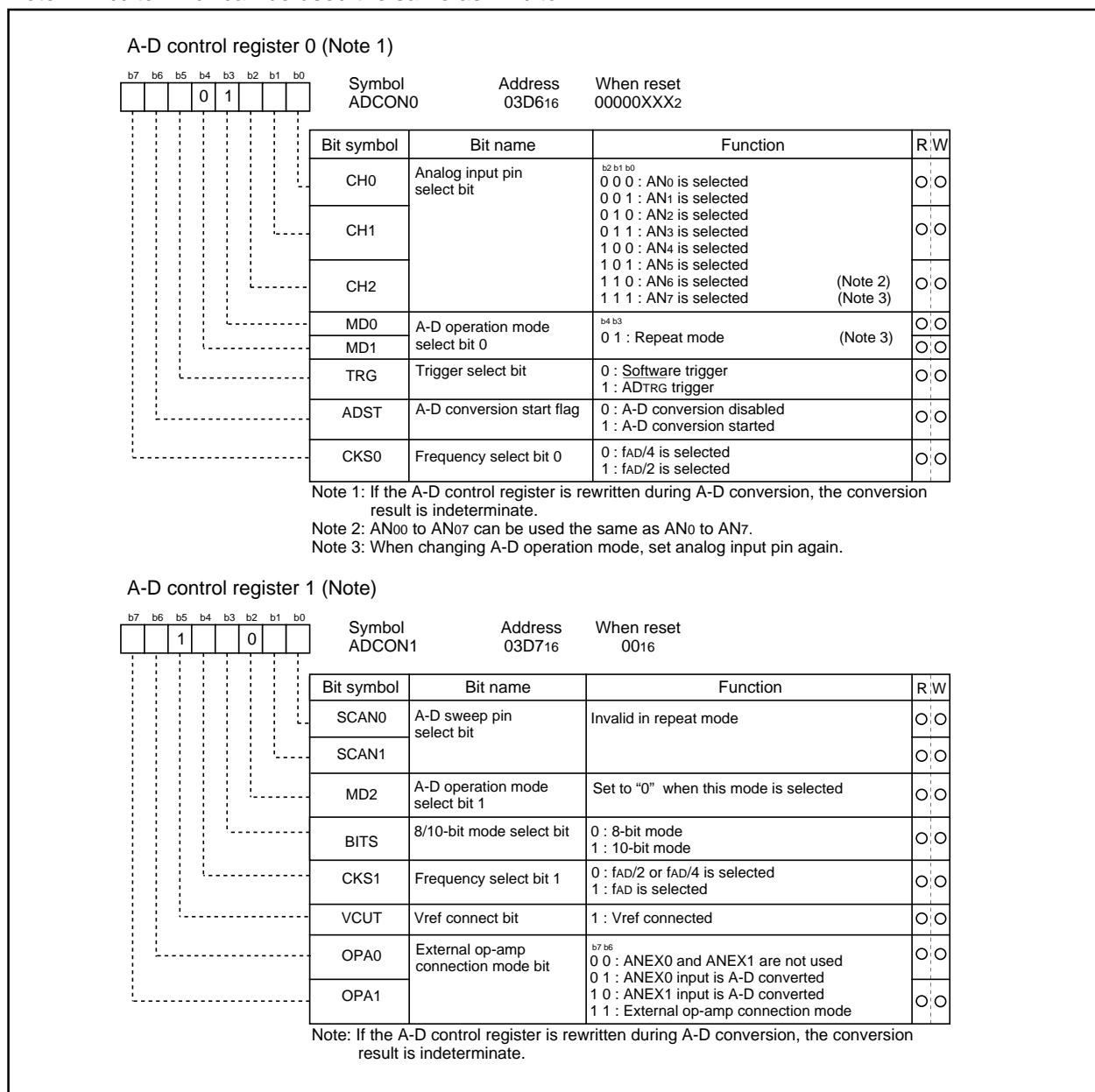

Figure 1.18.5. A-D conversion register in repeat mode

(3) Single sweep mode

In single sweep mode, the pins selected using the A-D sweep pin select bit are used for one-by-one A-D conversion. Table 1.18.4 shows the specifications of single sweep mode. Figure 1.18.6 shows the A-D control register in single sweep mode.

Table 1.18.4. Single sweep mode specifications

Item	Specification
Function	The pins selected by the A-D sweep pin select bit are used for one-by-one A-D conversion
Start condition	Writing "1" to A-D converter start flag
Stop condition	<ul style="list-style-type: none"> End of A-D conversion (A-D conversion start flag changes to "0", except when external trigger is selected) Writing "0" to A-D conversion start flag
Interrupt request generation timing	End of A-D conversion
Input pin	AN ₀ and AN ₁ (2 pins), AN ₀ to AN ₃ (4 pins), AN ₀ to AN ₅ (6 pins), or AN ₀ to AN ₇ (8 pins) (Note)
Reading of result of A-D converter	Read A-D register corresponding to selected pin

Note : AN₀₀ to AN₀₇ can be used the same as AN₀ to AN₇.

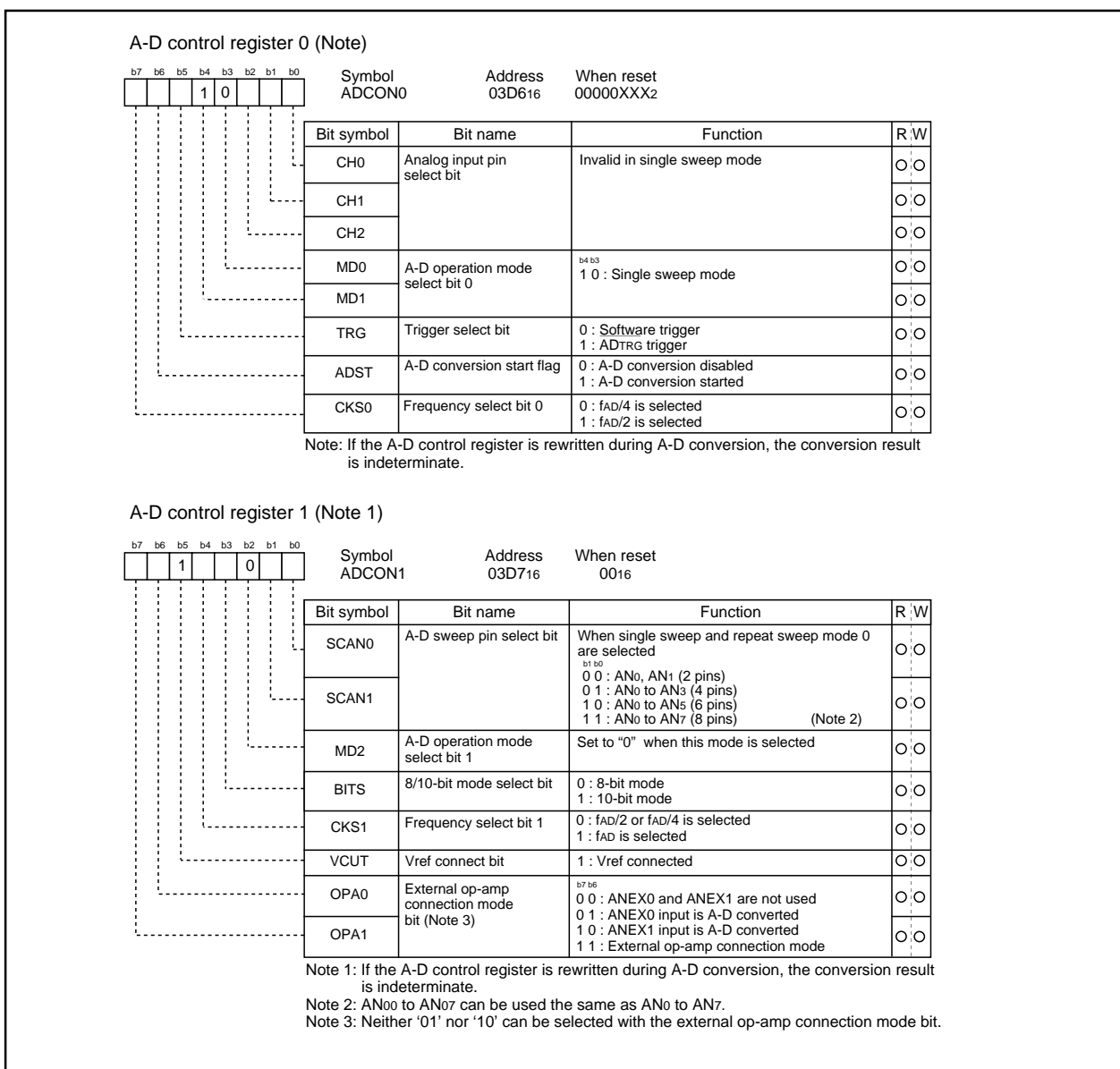

Figure 1.18.6. A-D conversion register in single sweep mode

(4) Repeat sweep mode 0

In repeat sweep mode 0, the pins selected using the A-D sweep pin select bit are used for repeat sweep A-D conversion. Table 1.18.5 shows the specifications of repeat sweep mode 0. Figure 1.18.7 shows the A-D control register in repeat sweep mode 0.

Table 1.18.5. Repeat sweep mode 0 specifications

Item	Specification
Function	The pins selected by the A-D sweep pin select bit are used for repeat A-D conversion
Start condition	Writing "1" to A-D conversion start flag
Stop condition	Writing "0" to A-D conversion start flag
Interrupt request generation timing	None generated
Input pin	AN0 and AN1 (2 pins), AN0 to AN3 (4 pins), AN0 to AN5 (6 pins), or AN0 to AN7 (8 pins) (Note)
Reading of result of A-D converter	Read A-D register corresponding to selected pin (at any time)

Note : AN00 to AN07 can be used the same as AN0 to AN7.

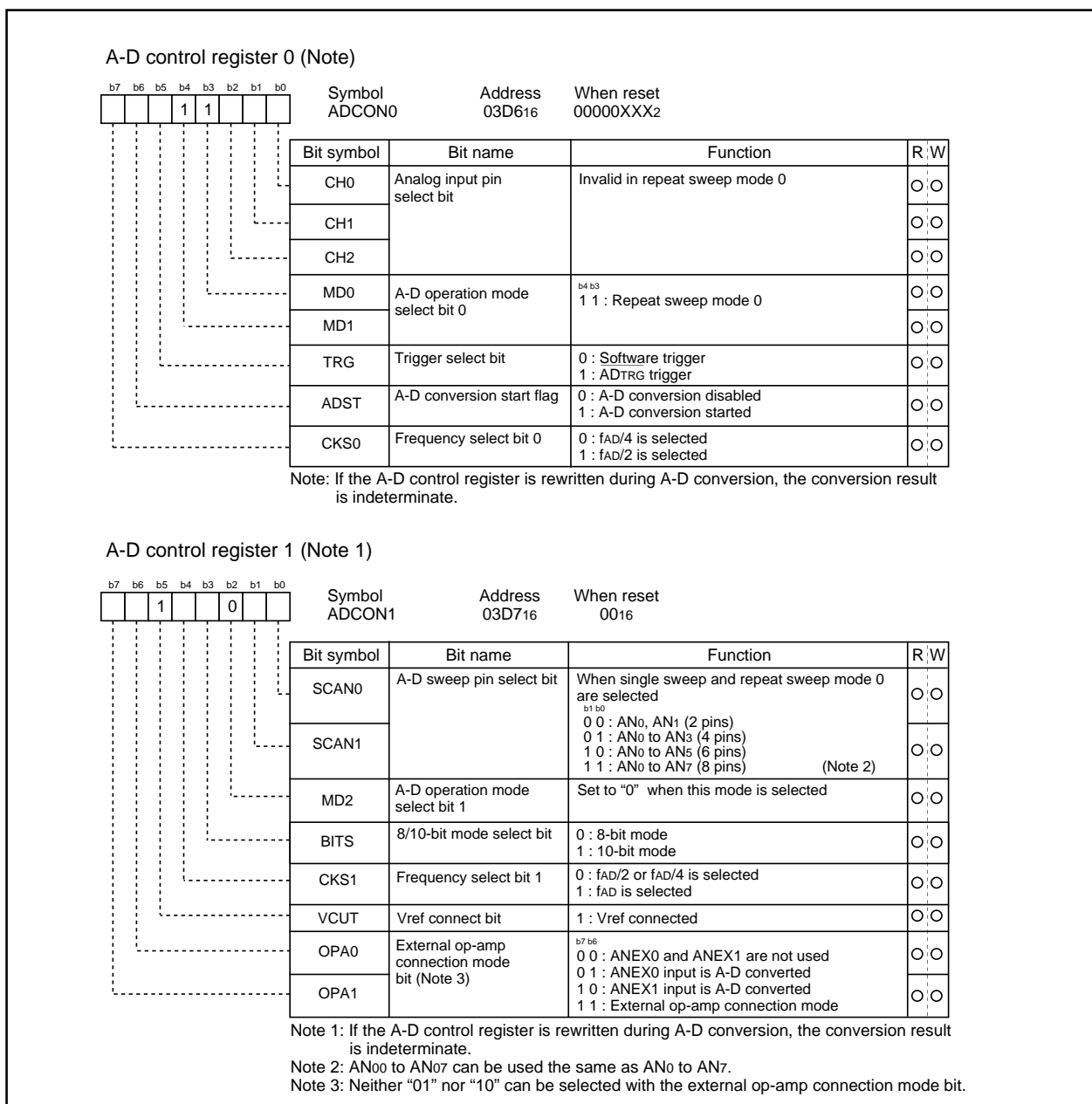

Figure 1.18.7. A-D conversion register in repeat sweep mode 0

(5) Repeat sweep mode 1

In repeat sweep mode 1, all pins are used for A-D conversion with emphasis on the pin or pins selected using the A-D sweep pin select bit. Table 1.18.6 shows the specifications of repeat sweep mode 1. Figure 1.18.8 shows the A-D control register in repeat sweep mode 1.

Table 1.18.6. Repeat sweep mode 1 specifications

Item	Specification
Function	All pins perform repeat A-D conversion, with emphasis on the pin or pins selected by the A-D sweep pin select bit Example : AN0 selected AN0 → AN1 → AN0 → AN2 → AN0 → AN3, etc
Start condition	Writing "1" to A-D conversion start flag
Stop condition	Writing "0" to A-D conversion start flag
Interrupt request generation timing	None generated
Input pin	With emphasis on these pins ; AN0 (1 pin), AN0 and AN1 (2 pins), AN0 to AN2 (3 pins), AN0 to AN3 (4 pins) (Note)
Reading of result of A-D converter	Read A-D register corresponding to selected pin (at any time)

Note : AN00 to AN07 can be used the same as AN0 to AN7.

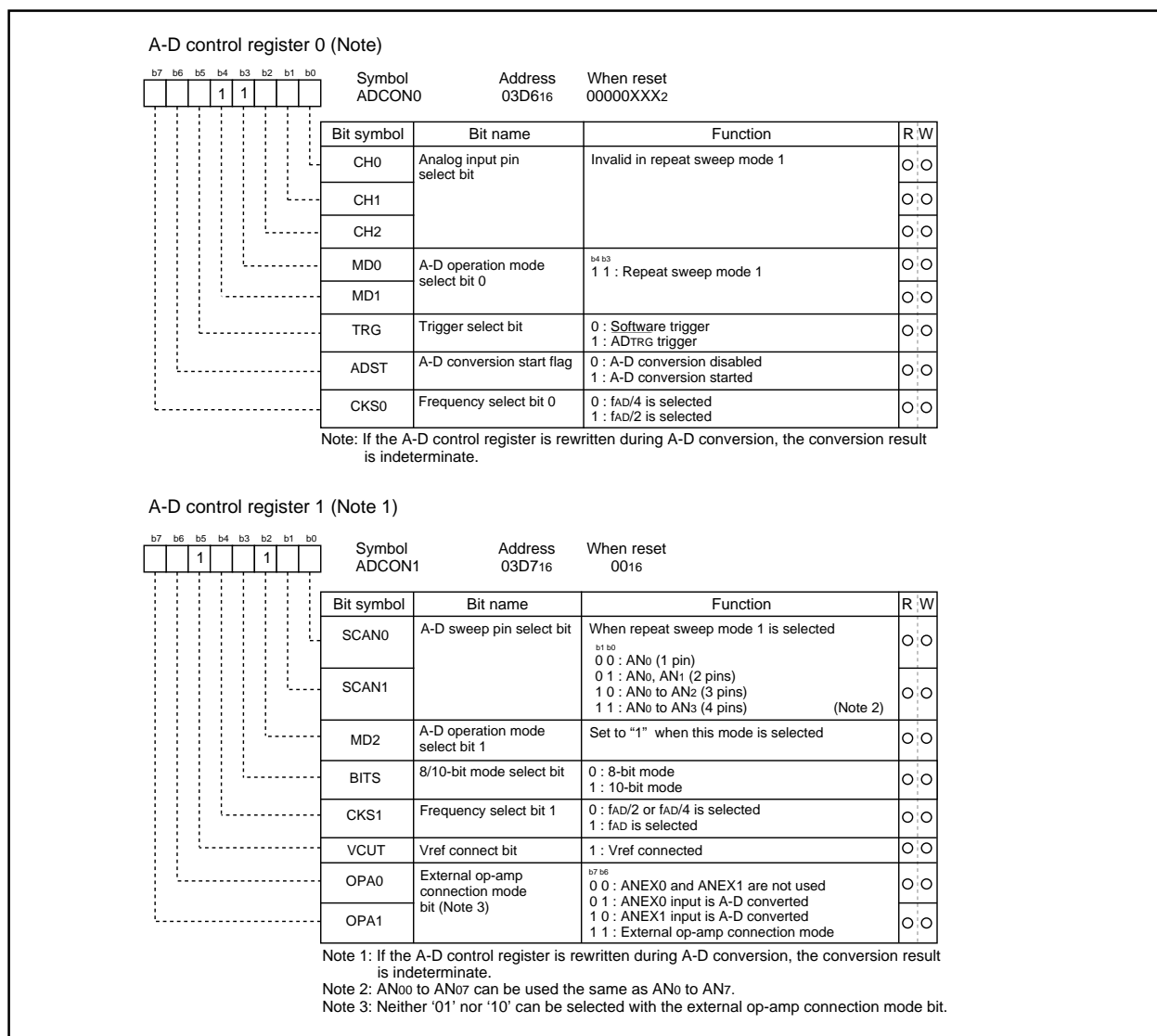

Figure 1.18.8. A-D conversion register in repeat sweep mode 1

(a) Sample and hold

Sample and hold is selected by setting bit 0 of the A-D control register 2 (address 03D416) to "1". When sample and hold is selected, the rate of conversion of each pin increases. As a result, a $28 \phi_{AD}$ cycle is achieved with 8-bit resolution and $33 \phi_{AD}$ with 10-bit resolution. Sample and hold can be selected in all modes. However, in all modes, be sure to specify before starting A-D conversion whether sample and hold is to be used.

(b) Extended analog input pins

In one-shot mode and repeat mode, the input via the extended analog input pins ANEX0 and ANEX1 can also be converted from analog to digital.

When bit 6 of the A-D control register 1 (address 03D716) is "1" and bit 7 is "0", input via ANEX0 is converted from analog to digital. The result of conversion is stored in A-D register 0.

When bit 6 of the A-D control register 1 (address 03D716) is "0" and bit 7 is "1", input via ANEX1 is converted from analog to digital. The result of conversion is stored in A-D register 1.

Furthermore, the input via 8 pins of the extended analog input pins AN00 to AN07 can be converted from analog to digital. These pins can be used the same as AN0 to AN7.

Use the A-D control register 2 (address 03D416) bit 1 and bit 2 to select the pin group AN0 to AN7, AN00 to AN07.

(c) External operation amp connection mode

In this mode, multiple external analog inputs via the extended analog input pins, ANEX0 and ANEX1, can be amplified together by just one operation amp and used as the input for A-D conversion.

When bit 6 of the A-D control register 1 (address 03D716) is "1" and bit 7 is "1", input via AN0 to AN7 (Note) is output from ANEX0. The input from ANEX1 is converted from analog to digital and the result stored in the corresponding A-D register. The speed of A-D conversion depends on the response of the external operation amp. Do not connect the ANEX0 and ANEX1 pins directly. Figure 1.18.9 is an example of how to connect the pins in external operation amp mode.

Note : AN00 to AN07 can be used the same as AN0 to AN7.

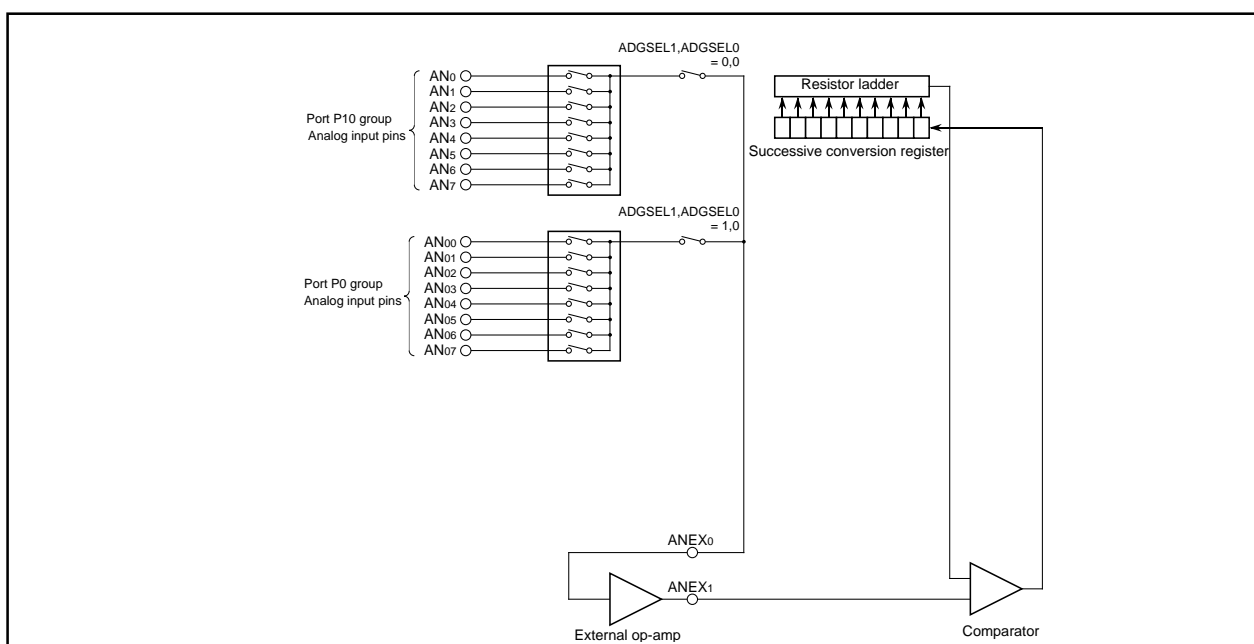

Figure 1.18.9. Example of external op-amp connection mode

D-A Converter

This is an 8-bit, R-2R type D-A converter. The microcomputer contains two independent D-A converters of this type.

D-A conversion is performed when a value is written to the corresponding D-A register. Bits 0 and 1 (D-A output enable bits) of the D-A control register decide if the result of conversion is to be output. Do not set the target port to output mode if D-A conversion is to be performed. When the D-A output is enabled, the pull-up function of the corresponding port is automatically disabled.

Output analog voltage (V) is determined by a set value (n : decimal) in the D-A register.

$$V = V_{REF} \times n / 256 \quad (n = 0 \text{ to } 255)$$

V_{REF} : reference voltage

Table 1.19.1 lists the performance of the D-A converter. Figure 1.19.1 shows the block diagram of the D-A converter. Figure 1.19.2 shows the D-A control register. Figure 1.19.3 shows the D-A converter equivalent circuit.

Table 1.19.1. Performance of D-A converter

Item	Performance
Conversion method	R-2R method
Resolution	8 bits
Analog output pin	2 channels

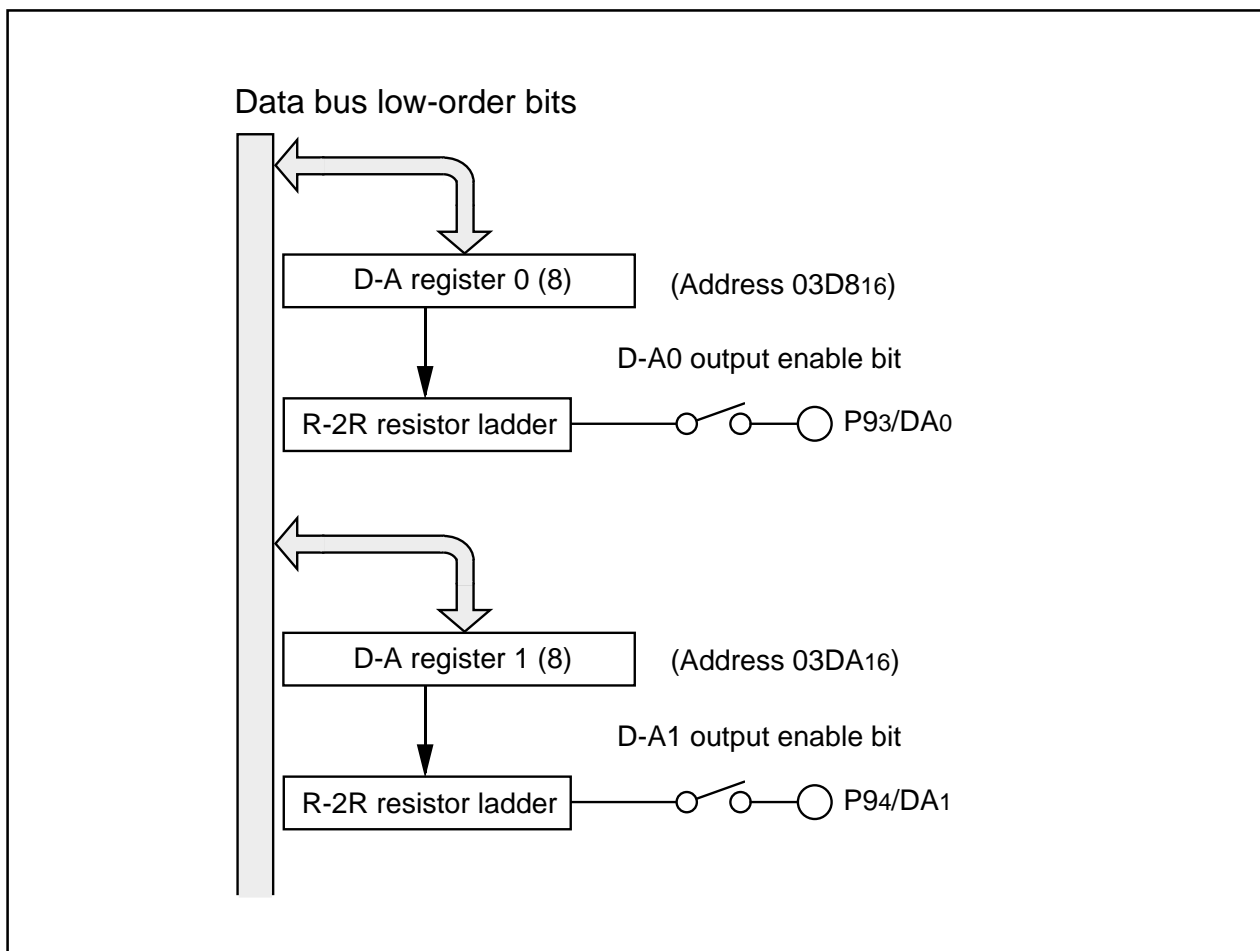

Figure 1.19.1. Block diagram of D-A converter

CRC Calculation Circuit

The Cyclic Redundancy Check (CRC) calculation circuit detects an error in data blocks. The microcomputer uses a generator polynomial of CRC_CCITT ($X^{16} + X^{12} + X^5 + 1$) to generate CRC code.

The CRC code is a 16-bit code generated for a block of a given data length in multiples of 8 bits. The CRC code is set in a CRC data register each time one byte of data is transferred to a CRC input register after writing an initial value into the CRC data register. Generation of CRC code for one byte of data is completed in two machine cycles.

Figure 1.20.1 shows the block diagram of the CRC circuit. Figure 1.20.2 shows the CRC-related registers. Figure 1.20.3 shows the calculation example using the CRC calculation circuit.

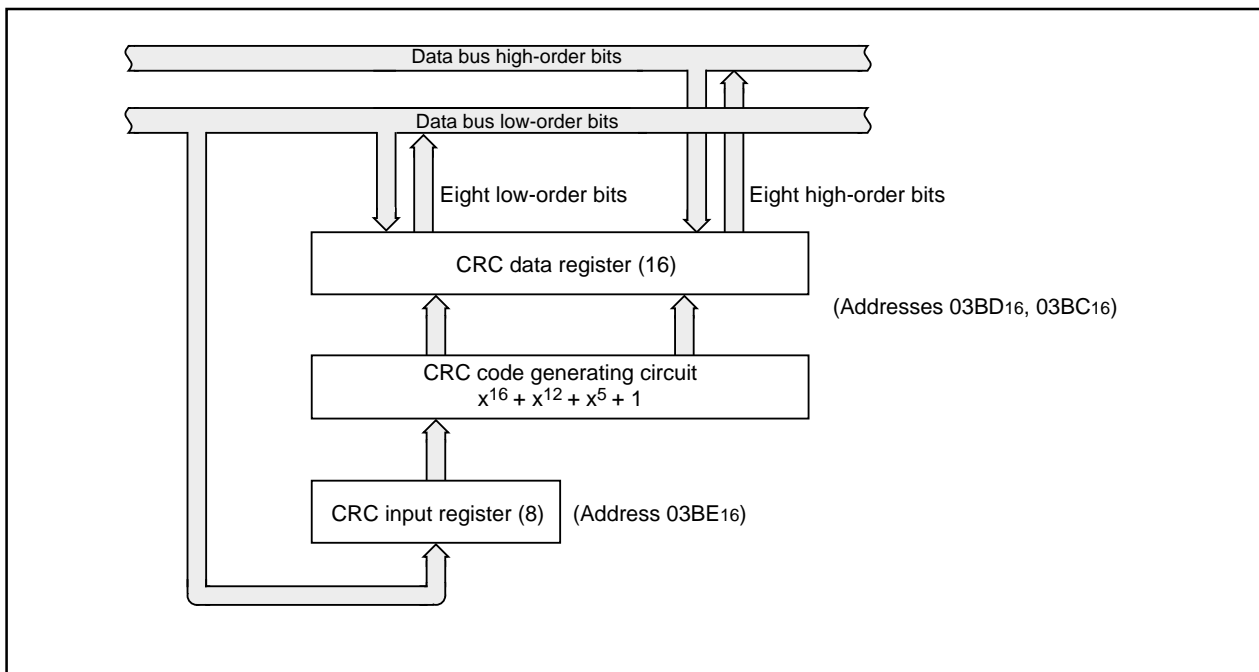

Figure 1.20.1. Block diagram of CRC circuit

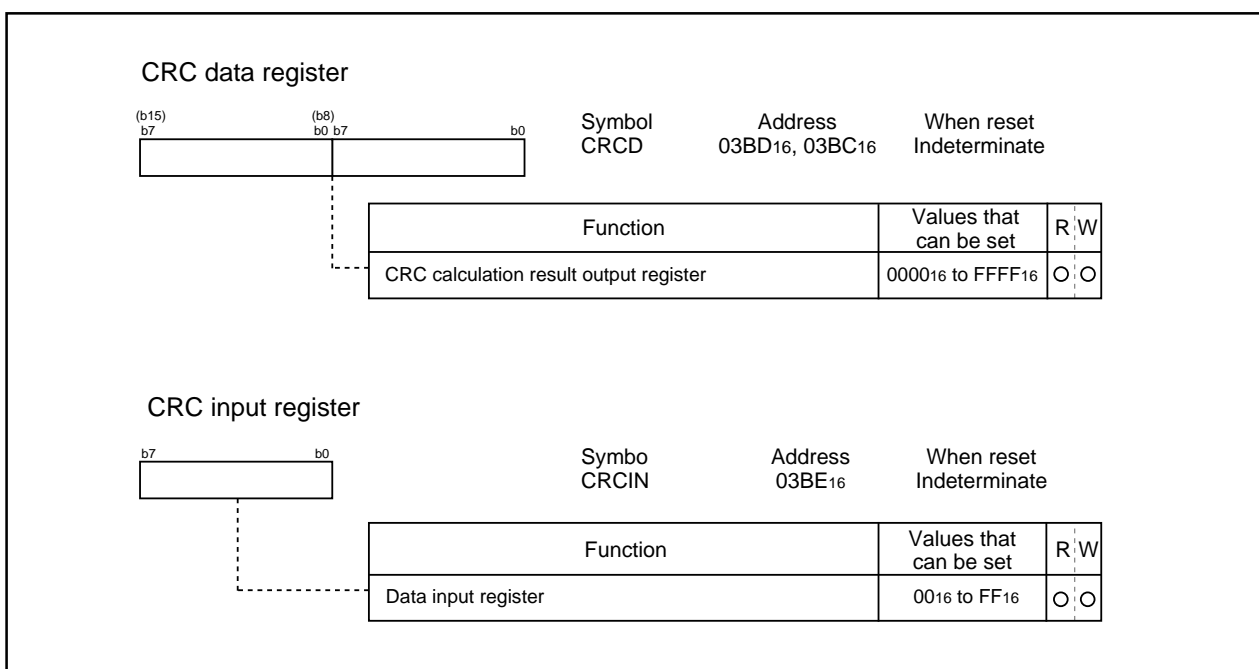

Figure 1.20.2. CRC-related registers

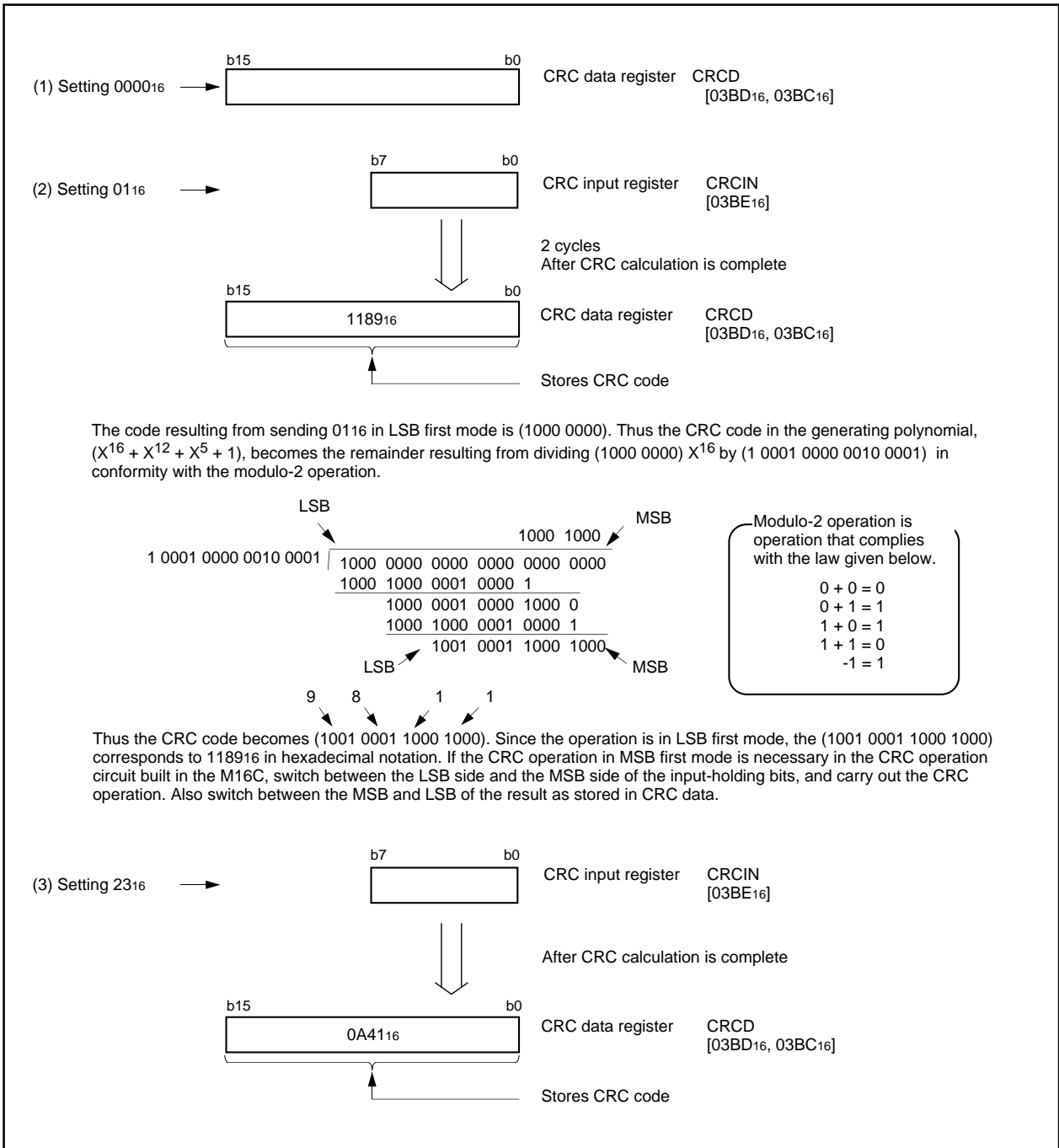

Figure 1.20.3. Calculation example using the CRC calculation circuit

Programmable I/O Ports

There are 87 programmable I/O ports: P0 to P10 (excluding P85). Each port can be set independently for input or output using the direction register. A pull-up resistance for each block of 4 ports can be set. P85 is an input-only port and has no built-in pull-up resistance.

Figures 1.21.1 to 1.21.4 show the programmable I/O ports. Figure 1.21.5 shows the I/O pins.

Each pin functions as a programmable I/O port and as the I/O for the built-in peripheral devices.

To use the pins as the inputs for the built-in peripheral devices, set the direction register of each pin to input mode. When the pins are used as the outputs for the built-in peripheral devices (other than the D-A converter), they function as outputs regardless of the contents of the direction registers. When pins are to be used as the outputs for the D-A converter, do not set the direction registers to output mode. See the descriptions of the respective functions for how to set up the built-in peripheral devices.

(1) Direction registers

Figure 1.21.6 shows the direction registers.

These registers are used to choose the direction of the programmable I/O ports. Each bit in these registers corresponds one for one to each I/O pin.

In memory expansion and microprocessor mode, the contents of corresponding direction register of pins A0 to A19, D0 to D15, $\overline{CS0}$ to $\overline{CS3}$, \overline{RD} , $\overline{WRL/WR}$, $\overline{WRH/BHE}$, ALE, \overline{RDY} , \overline{HOLD} , \overline{HLDA} and BCLK cannot be modified.

Note: There is no direction register bit for P85.

(2) Port registers

Figure 1.21.7 shows the port registers.

These registers are used to write and read data for input and output to and from an external device. A port register consists of a port latch to hold output data and a circuit to read the status of a pin. Each bit in port registers corresponds one for one to each I/O pin.

In memory expansion and microprocessor mode, the contents of corresponding port register of pins A0 to A19, D0 to D15, $\overline{CS0}$ to $\overline{CS3}$, \overline{RD} , $\overline{WRL/WR}$, $\overline{WRH/BHE}$, ALE, \overline{RDY} , \overline{HOLD} , \overline{HLDA} and BCLK cannot be modified.

(3) Pull-up control registers

Figure 1.21.8 shows the pull-up control registers.

The pull-up control register can be set to apply a pull-up resistance to each block of 4 ports. When ports are set to have a pull-up resistance, the pull-up resistance is connected only when the direction register is set for input.

However, in memory expansion mode and microprocessor mode, the pull-up control register of P0 to P3, P40 to P43, and P5 is invalid. The contents of register can be changed, but the pull-up resistance is not connected.

(4) Port control register

Figure 1.21.9 shows the port control register.

The bit 0 of port control register is used to read port P1 as follows:

0 : When port P1 is input port, port input level is read.

When port P1 is output port, the contents of port P1 register is read.

1 : The contents of port P1 register is read always.

This register is valid in the following:

- External bus width is 8 bits in microprocessor mode or memory expansion mode.
- Port P1 can be used as a port in multiplexed bus for the entire space.

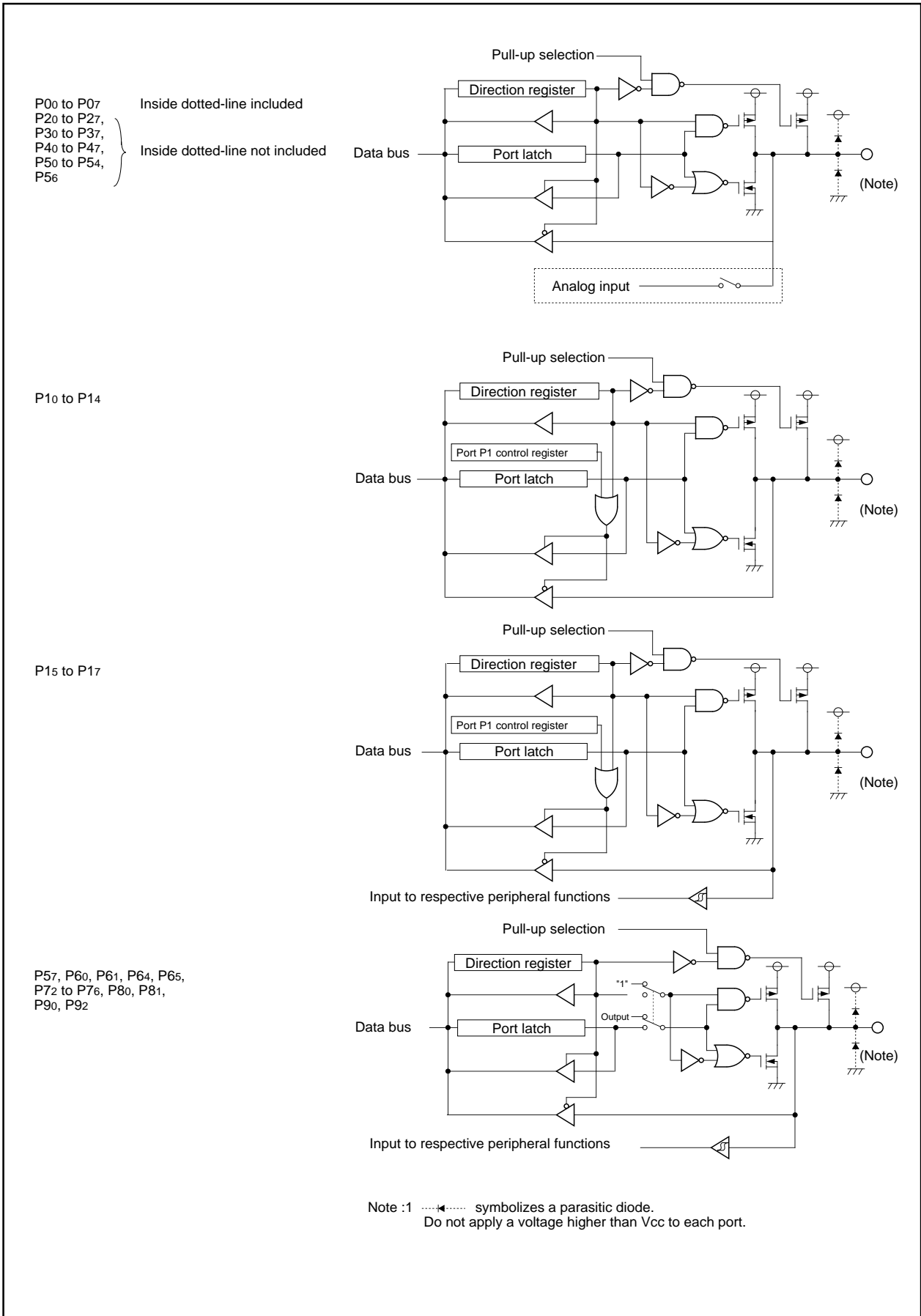

Figure 1.21.1. Programmable I/O ports (1)

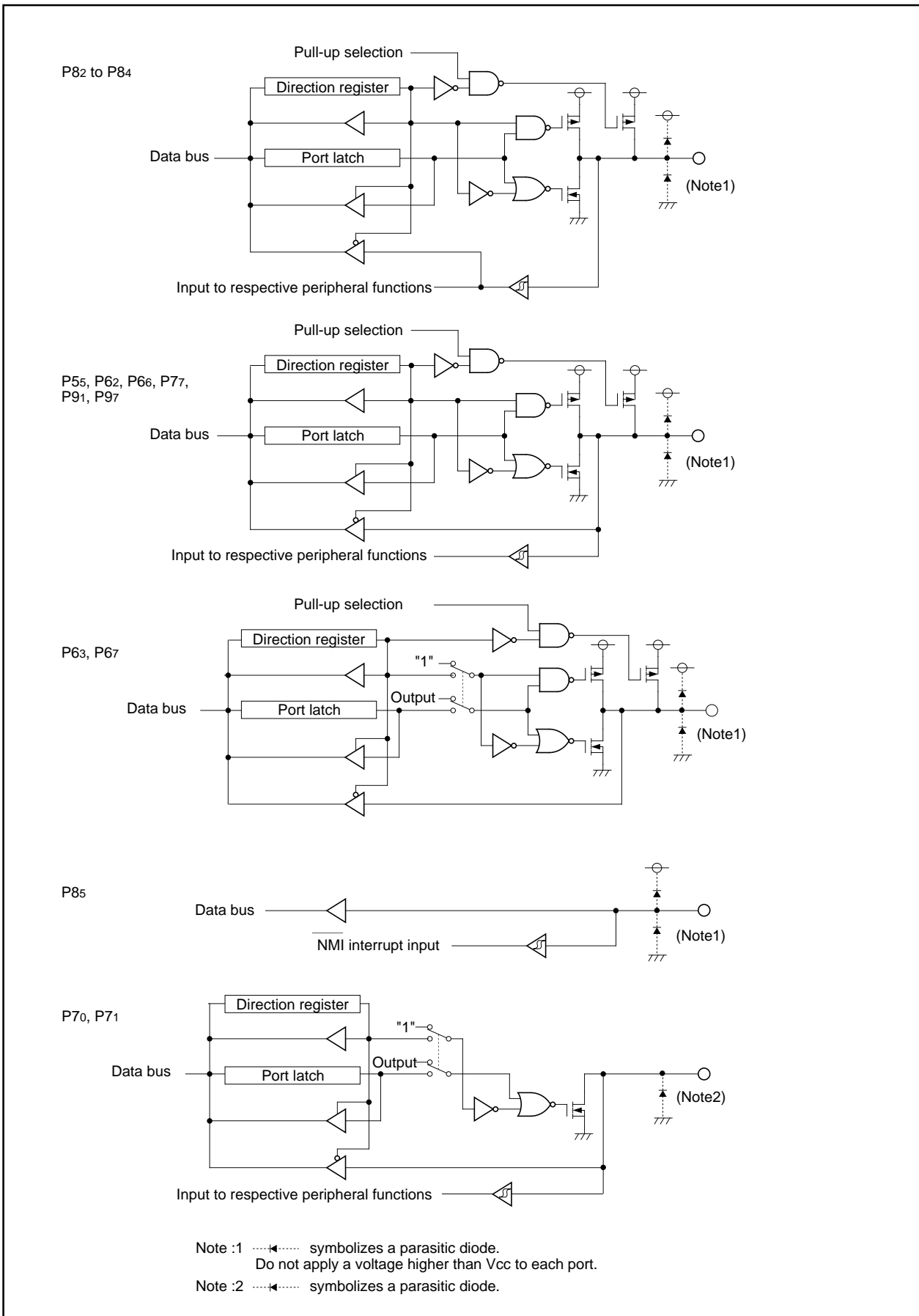

Figure 1.21.2. Programmable I/O ports (2)

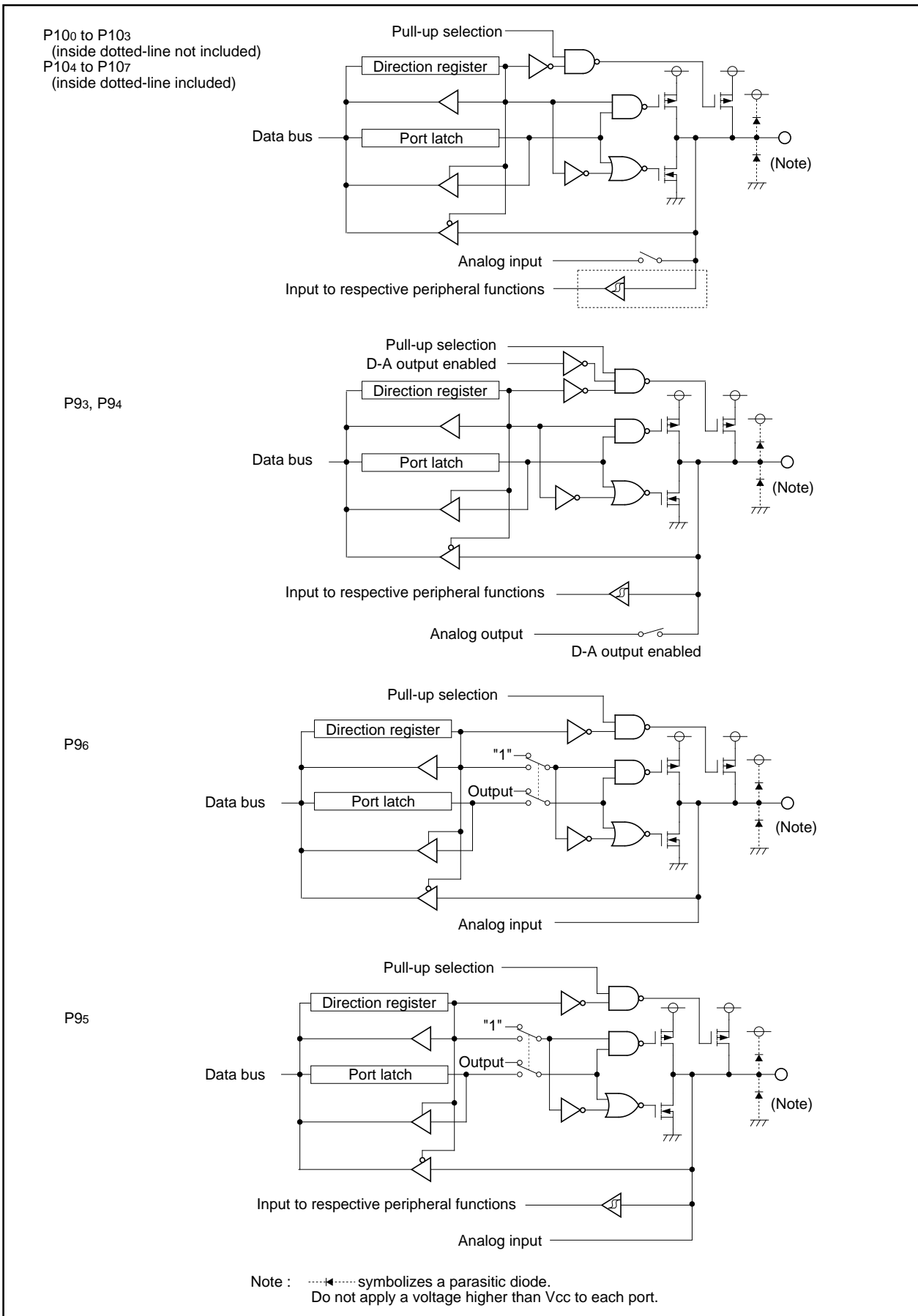

Figure 1.21.3. Programmable I/O ports (3)

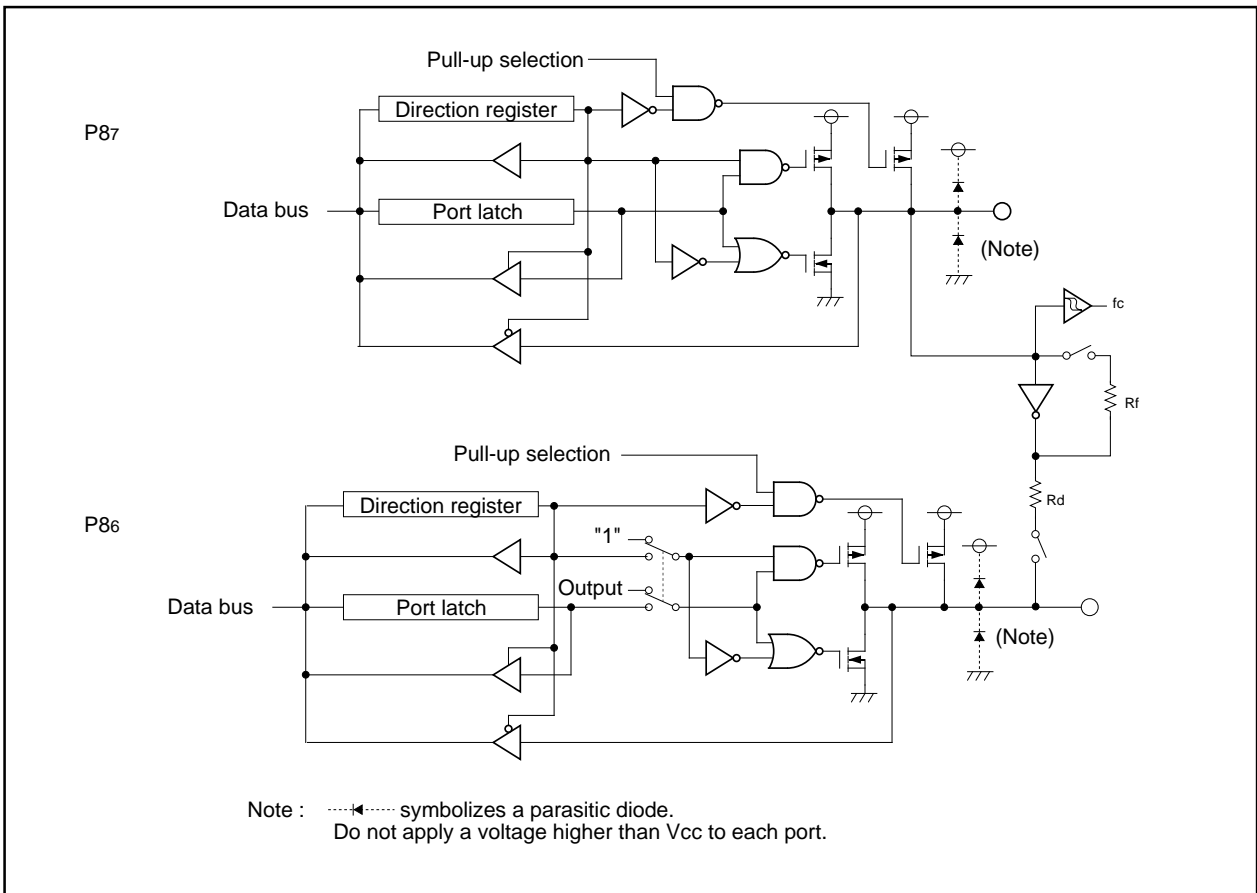

Figure 1.21.4. Programmable I/O ports (4)

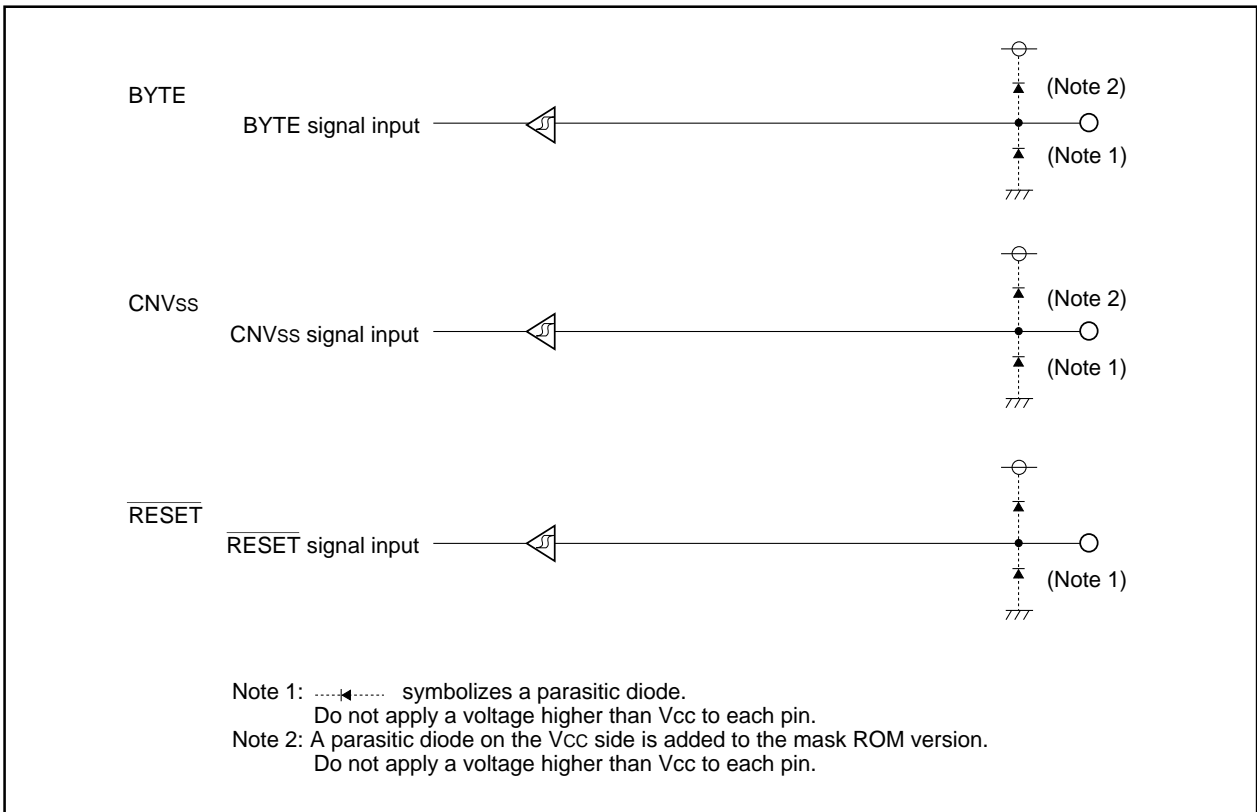

Figure 1.21.5. I/O pins

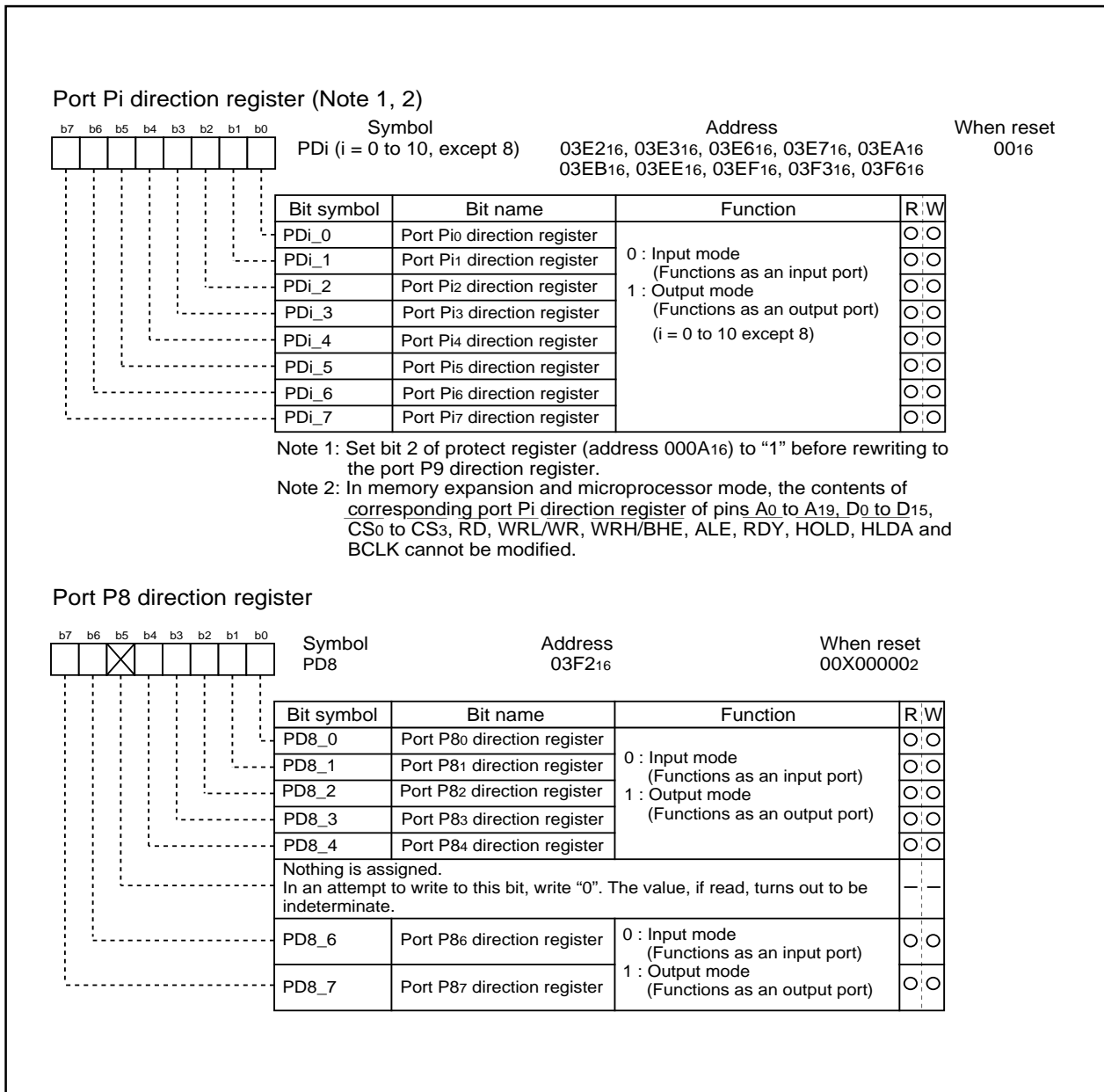

Figure 1.21.6. Direction register

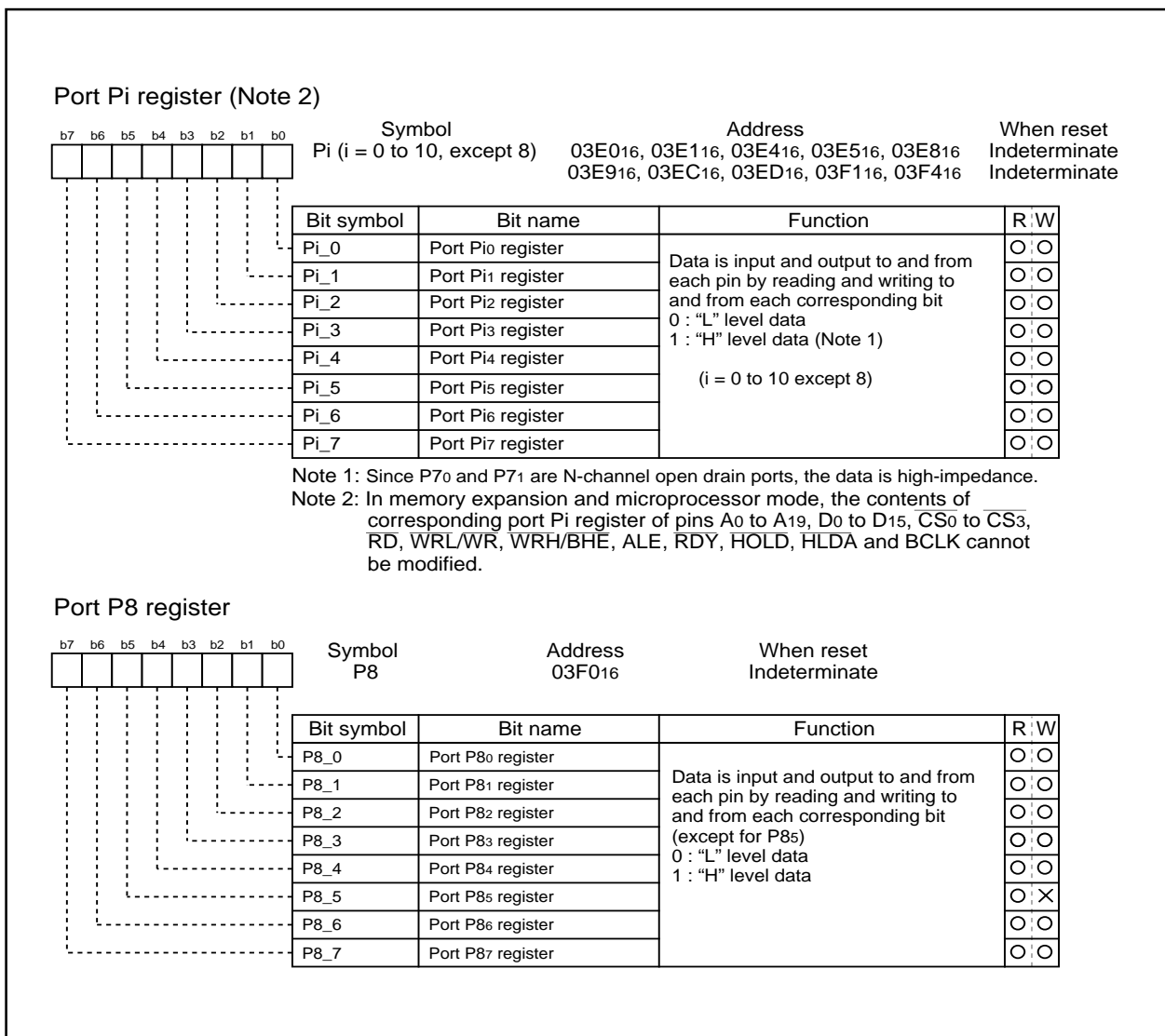

Figure 1.21.7. Port register

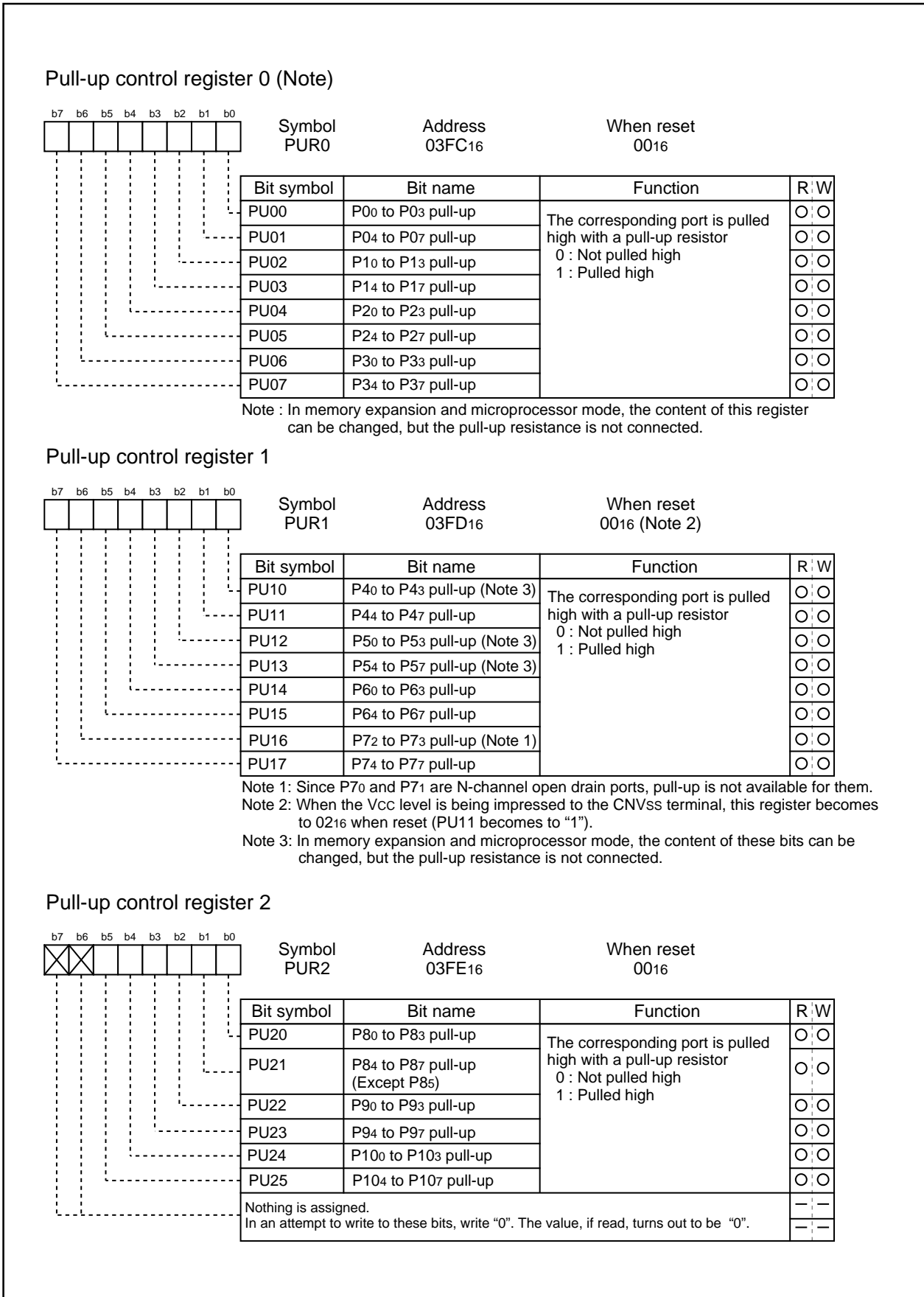

Figure 1.21.8. Pull-up control register

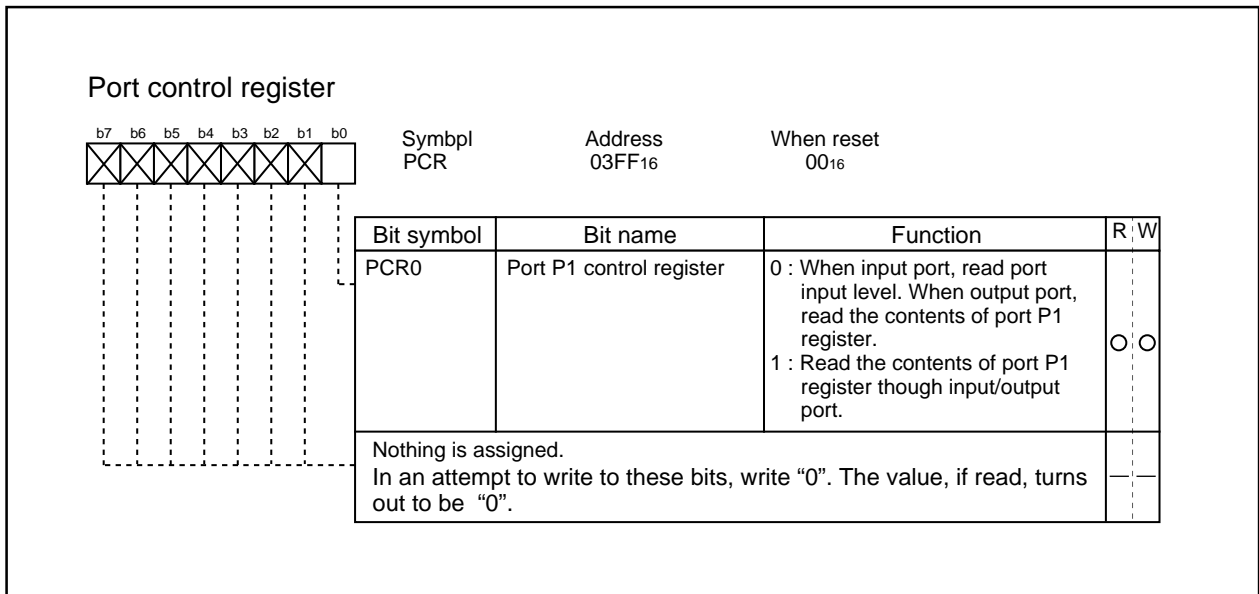

Figure 1.21.9. Port control register

Table 1.21.1. Example connection of unused pins in single-chip mode

Pin name	Connection
Ports P0 to P10 (excluding P85)	After setting for input mode, connect every pin to VSS via a resistor (pull-down); or after setting for output mode, leave these pins open.
XOUT (Note)	Open
$\overline{\text{NMI}}$	Connect via resistor to VCC (pull-up)
AVCC	Connect to VCC
AVSS, VREF, BYTE	Connect to VSS

Note: With external clock input to XIN pin.

Table 1.21.2. Example connection of unused pins in memory expansion mode and microprocessor mode

Pin name	Connection
Ports P6 to P10 (excluding P85)	After setting for input mode, connect every pin to VSS via a resistor (pull-down); or after setting for output mode, leave these pins open.
P45 / $\overline{\text{CS1}}$ to P47 / $\overline{\text{CS3}}$	Set ports to input mode, set output enable bits of $\overline{\text{CS1}}$ through $\overline{\text{CS3}}$ to 0, and connect to Vcc via resistors (pull-up).
$\overline{\text{BHE}}$, ALE, $\overline{\text{HLDA}}$, XOUT (Note 1), BCLK (Note 2)	Open
$\overline{\text{HOLD}}$, RDY, $\overline{\text{NMI}}$	Connect via resistor to VCC (pull-up)
AVCC	Connect to VCC
AVSS, VREF	Connect to VSS

Note 1: With external clock input to XIN pin.

Note 2: When the BCLK output disable bit (bit 7 at address 000416) is set to "1", connect to VCC via a resistor (pull-up).

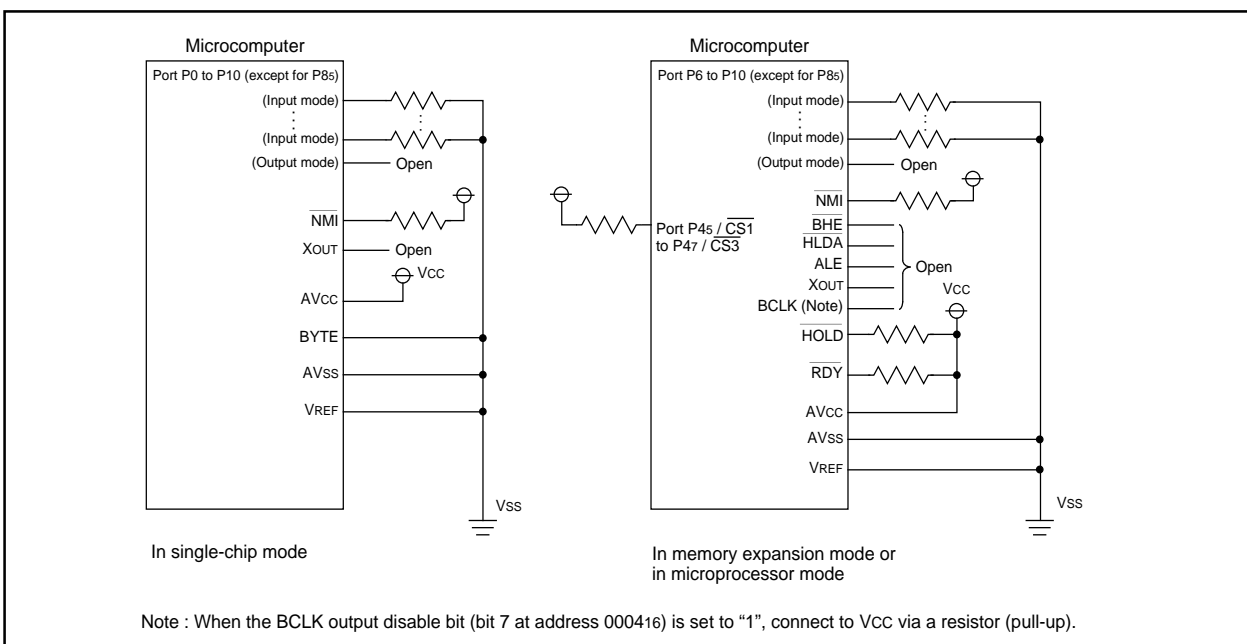

Figure 1.21.10. Example connection of unused pins

Electrical characteristics

Table 1.26.1. Absolute maximum ratings

Symbol	Parameter		Condition	Rated value	Unit
V _{cc}	Supply voltage		V _{cc} =AV _{cc}	- 0.3 to 4.2	V
AV _{cc}	Analog supply voltage		V _{cc} =AV _{cc}	- 0.3 to 4.2	V
V _i	Input voltage	RESET, CNV _{ss} , BYTE, P0 ₀ to P0 ₇ , P1 ₀ to P1 ₇ , P2 ₀ to P2 ₇ , P3 ₀ to P3 ₇ , P4 ₀ to P4 ₇ , P5 ₀ to P5 ₇ , P6 ₀ to P6 ₇ , P7 ₂ to P7 ₇ , P8 ₀ to P8 ₇ , P9 ₀ to P9 ₇ , P10 ₀ to P10 ₇ , V _{REF} , X _{IN}		- 0.3 to V _{cc} + 0.3	V
		P7 ₀ , P7 ₁		- 0.3 to 4.2	V
V _o	Output voltage	P0 ₀ to P0 ₇ , P1 ₀ to P1 ₇ , P2 ₀ to P2 ₇ , P3 ₀ to P3 ₇ , P4 ₀ to P4 ₇ , P5 ₀ to P5 ₇ , P6 ₀ to P6 ₇ , P7 ₂ to P7 ₇ , P8 ₀ to P8 ₄ , P8 ₆ , P8 ₇ , P9 ₀ to P9 ₇ , P10 ₀ to P10 ₇ , X _{OUT}		- 0.3 to V _{cc} + 0.3	V
		P7 ₀ , P7 ₁		- 0.3 to 4.2	V
P _d	Power dissipation		T _{opr} =25 °C	300	mW
T _{opr}	Operating ambient temperature			- 20 to 85 / -40 to 85 (Note)	°C
T _{stg}	Storage temperature			- 65 to 150	°C

Note: Specify a product of -40°C to 85°C to use it.

Table 1.26.2. Recommended operating conditions (referenced to V_{CC} = 2.4V (Mask ROM version is 2.2V) to 3.6V at Topr = -20°C to 85°C / - 40°C to 85°C(Note 3) unless otherwise specified)

Symbol	Parameter		Standard			Unit	
			Min.	Typ.	Max.		
V _{CC}	Supply voltage		2.4 (Note 4)	3.3	3.6	V	
AV _{CC}	Analog supply voltage			V _{CC}		V	
V _{SS}	Supply voltage			0		V	
AV _{SS}	Analog supply voltage			0		V	
V _{IH}	HIGH input voltage	P31 to P37, P40 to P47, P50 to P57, P60 to P67, P72 to P77, P80 to P87, P90 to P97, P100 to P107, X _{IN} , RESET, CNV _{SS} , BYTE	0.8V _{CC}		V _{CC}	V	
		P70, P71	0.8V _{CC}		4.2	V	
		P00 to P07, P10 to P17, P20 to P27, P30 (during single-chip mode)	0.8V _{CC}		V _{CC}	V	
		P00 to P07, P10 to P17, P20 to P27, P30 (data input function during memory expansion and microprocessor modes)	0.5V _{CC}		V _{CC}	V	
V _{IL}	LOW input voltage	P31 to P37, P40 to P47, P50 to P57, P60 to P67, P70 to P77, P80 to P87, P90 to P97, P100 to P107, X _{IN} , RESET, CNV _{SS} , BYTE	0		0.2V _{CC}	V	
		P00 to P07, P10 to P17, P20 to P27, P30 (during single-chip mode)	0		0.2V _{CC}	V	
		P00 to P07, P10 to P17, P20 to P27, P30 (data input function during memory expansion and microprocessor modes)	0		0.16V _{CC}	V	
I _{OH} (peak)	HIGH peak output current	P00 to P07, P10 to P17, P20 to P27, P30 to P37, P40 to P47, P50 to P57, P60 to P67, P72 to P77, P80 to P84, P86, P87, P90 to P97, P100 to P107			- 10.0	mA	
I _{OH} (avg)	HIGH average output current	P00 to P07, P10 to P17, P20 to P27, P30 to P37, P40 to P47, P50 to P57, P60 to P67, P72 to P77, P80 to P84, P86, P87, P90 to P97, P100 to P107			- 5.0	mA	
I _{OL} (peak)	LOW peak output current	P00 to P07, P10 to P17, P20 to P27, P30 to P37, P40 to P47, P50 to P57, P60 to P67, P70 to P77, P80 to P84, P86, P87, P90 to P97, P100 to P107			10.0	mA	
I _{OL} (avg)	LOW average output current	P00 to P07, P10 to P17, P20 to P27, P30 to P37, P40 to P47, P50 to P57, P60 to P67, P70 to P77, P80 to P84, P86, P87, P90 to P97, P100 to P107			5.0	mA	
f (X _{IN})	Main clock input oscillation frequency (Note 5, Note 6)	No wait	Mask ROM version	V _{CC} =3.0V to 3.6V	0	16	MHz
			Flash memory version	V _{CC} =2.4V to 3.0V	0	15 X V _{CC} - 29	MHz
			Mask ROM version	V _{CC} =2.2V to 2.4V	0	17.5 X V _{CC} - 35	MHz
		With wait	Mask ROM version	V _{CC} =3.0V to 3.6V	0	16	MHz
			Flash memory version	V _{CC} =2.4V to 3.0V	0	11.25 X V _{CC} - 17.75	MHz
			Mask ROM version	V _{CC} =2.2V to 2.4V	0	11.25 X V _{CC} - 17.75	MHz
f (X _{CIN})	Subclock oscillation frequency			32.768	50	kHz	

Note 1: The mean output current is the mean value within 100ms.

Note 2: The total I_{OL} (peak) for ports P0, P1, P2, P86, P87, P9, and P10 must be 80mA max. The total I_{OH} (peak) for ports P0, P1, P2, P86, P87, P9, and P10 must be 80mA max. The total I_{OL} (peak) for ports P3, P4, P5, P6, P7, and P80 to P84 must be 80mA max. The total I_{OH} (peak) for ports P3, P4, P5, P6, P72 to P77, and P80 to P84 must be 80mA max.

Note 3: Specify a product of -40°C to 85°C to use it.

Note 4: 2.2V is minimum supply voltage of mask ROM version.

Note 5: Relationship between main clock oscillation frequency and supply voltage.

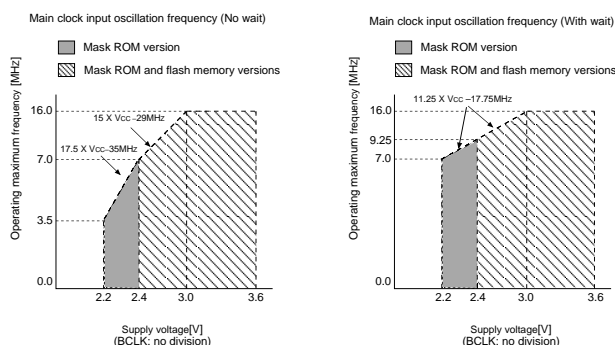

Flash memory version program/erase voltage and read operation voltage characteristics

Flash program/erase voltage	Flash read operation voltage
V _{CC} =3.0V to 3.6V	V _{CC} =2.4V to 3.6V

Note 6: Execute case without wait, program / erase of flash memory by V_{CC}=3.0V to 3.6V and f(BCLK) ≤ 6.25 MHz. Execute case with wait, program / erase of flash memory by V_{CC}=3.0V to 3.6V and f(BCLK) ≤ 10.0 MHz.

Table 1.26.3. Electrical characteristics (referenced to VCC = 3.0V to 3.6V, VSS = 0V at Topr = - 20°C to 85°C / - 40°C to 85°C (Note 1), f(XIN) = 16MHZ unless otherwise specified)

Symbol	Parameter		Measuring condition	Standard			Unit	
				Min	Typ.	Max.		
VOH	HIGH output voltage P00 to P07, P10 to P17, P20 to P27, P30 to P37, P40 to P47, P50 to P57, P60 to P67, P70 to P77, P80 to P84, P86, P87, P90 to P97, P100 to P107		IOH = -1mA VCC = 3.3V	2.8			V	
VOH	HIGH output voltage XOUT	HIGHPOWER	IOH = -0.1mA, VCC = 3.3V	2.8			V	
		LOWPOWER	IOH = -50µA, VCC = 3.3V	2.8				
	HIGH output voltage XCOUT	HIGHPOWER	With no load applied, VCC = 3.3V		2.8		V	
		LOWPOWER	With no load applied, VCC = 3.3V		1.6			
VOL	LOW output voltage P00 to P07, P10 to P17, P20 to P27, P30 to P37, P40 to P47, P50 to P57, P60 to P67, P70 to P77, P80 to P84, P86, P87, P90 to P97, P100 to P107		IOL = 1mA VCC = 3.3V			0.5	V	
VOL	LOW output voltage XOUT	HIGHPOWER	IOL = 0.1mA, VCC = 3.3V			0.5	V	
		LOWPOWER	IOL = 50µA, VCC = 3.3V			0.5		
	LOW output voltage XCOUT	HIGHPOWER	With no load applied, VCC = 3.3V		0		V	
		LOWPOWER	With no load applied, VCC = 3.3V		0			
VT+-VT-	Hysteresis	HOLD, RDY, TA0IN to TA4IN, TB0IN to TB5IN, INT0 to INT5, NMI, ADTRG, CTS0 to CTS2, SCL, SDA CLK0 to CLK4, TA2OUT to TA4OUT, K10 to K13, RxD0 to RxD2, SIN3, SIN4	VCC = 3.3V	0.2		0.8	V	
VT+-VT-	Hysteresis	RESET	VCC = 3.3V	0.2		1.8	V	
IiH	HIGH input current	P00 to P07, P10 to P17, P20 to P27, P30 to P37, P40 to P47, P50 to P57, P60 to P67, P70 to P77, P80 to P87, P90 to P97, P100 to P107, XIN, RESET, CNVss, BYTE	Vi = 3V VCC = 3.3V			4.0	µA	
IiL	LOW input current	P00 to P07, P10 to P17, P20 to P27, P30 to P37, P40 to P47, P50 to P57, P60 to P67, P70 to P77, P80 to P87, P90 to P97, P100 to P107, XIN, RESET, CNVss, BYTE	Vi = 0V VCC = 3.3V			-4.0	µA	
R PULLUP	Pull-up resistance	P00 to P07, P10 to P17, P20 to P27, P30 to P37, P40 to P47, P50 to P57, P60 to P67, P70 to P77, P80 to P84, P86, P87, P90 to P97, P100 to P107	Vi = 0V VCC = 3.3V	20.0	100.0	500.0	kΩ	
R iXIN	Feedback resistance	XIN			3.0		MΩ	
R iXCIN	Feedback resistance	XCIN			10.0		MΩ	
V RAM	RAM retention voltage		When clock is stopped	2.0			V	
Icc	Power supply current		In single-chip mode, the output pins are open and other pins are Vss	Mask ROM version	f(XIN) = 16MHz, Square wave, no division	12.5	25.0	mA
				Flash memory version	f(XIN) = 16MHz Square wave, no division	20.0	32.0	
				Mask ROM version	f(XCIN) = 32kHz, VCC = 3.3V Square wave	40.0		µA
				Flash memory version	f(XCIN) = 32kHz, VCC = 3.3V Square wave, in RAM(Note 3)	45		µA
				Flash memory version	f(XCIN) = 32kHz, VCC = 3.3V Square wave, in flash memory	225		µA
				Flash memory version program	f(XIN) = 16MHz, VCC = 3.3V Division by 2	19.0		mA
				Flash memory version erase	f(XIN) = 16MHz, VCC = 3.3V Division by 2	21.0		mA
				Mask ROM version	f(XCIN) = 32kHz, VCC = 3.3V When a WAIT instruction is executed. Oscillation capacity High (Note 2)	5.8		µA
					f(XCIN) = 32kHz, VCC = 3.3V When a WAIT instruction is executed. Oscillation capacity Low (Note 2)	2.7		µA
				Flash memory version	f(XCIN) = 32kHz, VCC = 3.3V When a WAIT instruction is executed. Oscillation capacity High (Note 2)	7.0		µA
					f(XCIN) = 32kHz, VCC = 3.3V When a WAIT instruction is executed. Oscillation capacity Low (Note 2)	3.0		µA
				Flash memory version and mask ROM version	Topr = 25°C, VCC = 3.3V when clock is stopped	0.1	2.0	µA
Topr = 85°C, VCC = 3.3V when clock is stopped	0.4	100						

Note 1: Specify a product of -40°C to 85°C to use it.

Note 2: With one timer operated using fc32.

Note 3: Refer to the shifting to the low power dissipation mode flowchart (Figure 1.29.2b).

Table 1.26.4. A-D conversion characteristics (referenced to $V_{CC} = AV_{CC} = V_{REF} = 2.4V$ to $3.6V$, $V_{SS} = AV_{SS} = 0V$, at $T_{opr} = -20^{\circ}C$ to $85^{\circ}C$ / $-40^{\circ}C$ to $85^{\circ}C$ (Note 4), $f(X_{IN}) = 16MHz$ unless otherwise specified)

Symbol	Parameter		Measuring condition	Standard			Unit	
				Min.	Typ.	Max.		
-	Resolution		$V_{REF} = V_{CC}$			10	Bits	
-	Absolute accuracy	Sample & hold function not available	$V_{REF} = V_{CC} = 3.3V$		± 2	± 5	LSB	
		Sample & hold function available(10bit)	$V_{REF} = V_{CC} = 3.3V$	AN0 to AN7 input		± 2	± 5	LSB
				ANEX0, ANEX1 input, AN00 to AN07 input			± 7	LSB
	Sample & hold function available(8bit)	$V_{REF} = V_{CC} = 3.3V$			± 2	LSB		
R_{LADDER}	Ladder resistance		$V_{REF} = V_{CC}$	10		40	$k\Omega$	
t_{CONV}	Conversion time(10bit)			3.3			μs	
t_{CONV}	Conversion time(8bit)			2.8			μs	
t_{SAMP}	Sampling time			0.3			μs	
V_{REF}	Reference voltage			2.4		V_{CC}	V	
V_{IA}	Analog input voltage			0		V_{REF}	V	

Note 1: Do $f(X_{IN})$ in range of main clock input oscillation frequency prescribed with recommended operating conditions of table 1.26.2. Divide the f_{AD} if $f(X_{IN})$ exceeds 10MHz, and make AD operation clock frequency ($\emptyset AD$) equal to or lower than 10MHz. And divide the f_{AD} if V_{CC} is less than 3.0V, and make AD operation clock frequency ($\emptyset AD$) equal to or lower than $f_{AD}/2$.

Note 2: A case without sample & hold function turn AD operation clock frequency ($\emptyset AD$) into 250 kHz or more in addition to a limit of Note 1.

A case with sample & hold function turn AD operation clock frequency ($\emptyset AD$) into 1MHz or more in addition to a limit of Note 1.

Note 3: Connect AV_{CC} pin to V_{CC} pin and apply the same electric potential.

Note 4: Specify a product of $-40^{\circ}C$ to $85^{\circ}C$ to use it.

Table 1.26.5. D-A conversion characteristics (referenced to $V_{CC} = V_{REF} = 2.4V$ to $3.6V$, $V_{SS} = AV_{SS} = 0V$, at $T_{opr} = -20^{\circ}C$ to $85^{\circ}C$ / $-40^{\circ}C$ to $85^{\circ}C$ (Note 2), $f(X_{IN}) = 16MHz$ unless otherwise specified)

Symbol	Parameter	Measuring condition	Standard			Unit
			Min.	Typ.	Max	
-	Resolution				8	Bits
-	Absolute accuracy, $V_{REF} = V_{CC} = 3.3V$				1.0	%
t_{su}	Setup time				3	μs
R_O	Output resistance		4	15	25	$k\Omega$
I_{VREF}	Reference power supply input current	(Note1)			1.0	mA

Note 1: This applies when using one D-A converter, with the D-A register for the unused D-A converter set to "0016".

The A-D converter's ladder resistance is not included.

Also, when D-A register contents are not "0016", the current I_{VREF} always flows even though V_{ref} may have been set to be unconnected by the A-D control register.

Note 2: Specify a product of $-40^{\circ}C$ to $85^{\circ}C$ to use it.

Table 1.26.6. Flash memory version electrical characteristics

(referenced to $V_{CC} = 3.0V$ to $3.6V$, at $T_{opr} = 0^{\circ}C$ to $60^{\circ}C$ unless otherwise specified)

Parameter	Standard			Unit
	Min.	Typ.	Max	
Word program time		15	150	μs
4K block erase time		0.3	8	s
64K block erase time		0.5	8	s
Erase all unlocked blocks time		$0.5 \times n$	$8 \times n$	s
Lock bit program time		0.02	0.4	ms

Note : n denotes the number of block erases.

Table 1.26.7. Flash memory version program/erase voltage and read operation voltage characteristics (at $T_{opr} = 0^{\circ}C$ to $60^{\circ}C$)

Flash program/erase voltage	Flash read operation voltage
$V_{CC} = 3.0V$ to $3.6V$	$V_{CC} = 2.4V$ to $3.6V$

Timing requirements(referenced to $V_{CC} = 3.3V$, $V_{SS} = 0V$, at $T_{opr} = -20^{\circ}C$ to $85^{\circ}C$ / $-40^{\circ}C$ to $85^{\circ}C$ (*) unless otherwise specified)* : Specify a product of $-40^{\circ}C$ to $85^{\circ}C$ to use it.**Table 1.26.8. External clock input**

Symbol	Parameter	Standard		Unit
		Min.	Max.	
t_c	External clock input cycle time	62.5		ns
$t_{w(H)}$	External clock input HIGH pulse width	25		ns
$t_{w(L)}$	External clock input LOW pulse width	25		ns
t_r	External clock rise time		15	ns
t_f	External clock fall time		15	ns

Table 1.26.9. Memory expansion and microprocessor modes

Symbol	Parameter	Standard		Unit
		Min.	Max.	
$t_{ac1(RD-DB)}$	Data input access time (no wait)		(Note)	ns
$t_{ac2(RD-DB)}$	Data input access time (with wait)		(Note)	ns
$t_{ac3(RD-DB)}$	Data input access time (when accessing multiplex bus area)		(Note)	ns
$t_{su(DB-RD)}$	Data input setup time	50		ns
$t_{su(RDY-BCLK)}$	RDY input setup time	50		ns
$t_{su(HOLD-BCLK)}$	HOLD input setup time	100		ns
$t_h(RD-DB)$	Data input hold time	0		ns
$t_h(BCLK-RDY)$	RDY input hold time	0		ns
$t_h(BCLK-HOLD)$	HOLD input hold time	0		ns
$t_d(BCLK-HLDA)$	HLDA output delay time		40	ns

Note: Calculated according to the BCLK frequency as follows:

$$t_{ac1(RD-DB)} = \frac{10^9}{f(BCLK) \times 2} - 90 \quad [ns]$$

$$t_{ac2(RD-DB)} = \frac{3 \times 10^9}{f(BCLK) \times 2} - 90 \quad [ns]$$

$$t_{ac3(RD-DB)} = \frac{3 \times 10^9}{f(BCLK) \times 2} - 90 \quad [ns]$$

Timing requirements(referenced to $V_{CC} = 3.3V$, $V_{SS} = 0V$, at $T_{opr} = -20^{\circ}C$ to $85^{\circ}C$ / $-40^{\circ}C$ to $85^{\circ}C$ (*) unless otherwise specified)* : Specify a product of $-40^{\circ}C$ to $85^{\circ}C$ to use it.**Table 1.26.10. Timer A input (counter input in event counter mode)**

Symbol	Parameter	Standard		Unit
		Min.	Max.	
$t_{c(TA)}$	TAiIN input cycle time	100		ns
$t_{w(TAH)}$	TAiIN input HIGH pulse width	40		ns
$t_{w(TAL)}$	TAiIN input LOW pulse width	40		ns

Table 1.26.11. Timer A input (gating input in timer mode)

Symbol	Parameter	Standard		Unit
		Min.	Max.	
$t_{c(TA)}$	TAiIN input cycle time	400		ns
$t_{w(TAH)}$	TAiIN input HIGH pulse width	200		ns
$t_{w(TAL)}$	TAiIN input LOW pulse width	200		ns

Table 1.26.12. Timer A input (external trigger input in one-shot timer mode)

Symbol	Parameter	Standard		Unit
		Min.	Max.	
$t_{c(TA)}$	TAiIN input cycle time	200		ns
$t_{w(TAH)}$	TAiIN input HIGH pulse width	100		ns
$t_{w(TAL)}$	TAiIN input LOW pulse width	100		ns

Table 1.26.13. Timer A input (external trigger input in pulse width modulation mode)

Symbol	Parameter	Standard		Unit
		Min.	Max.	
$t_{w(TAH)}$	TAiIN input HIGH pulse width	100		ns
$t_{w(TAL)}$	TAiIN input LOW pulse width	100		ns

Table 1.26.14. Timer A input (up/down input in event counter mode)

Symbol	Parameter	Standard		Unit
		Min.	Max.	
$t_{c(UP)}$	TAiOUT input cycle time	2000		ns
$t_{w(UPH)}$	TAiOUT input HIGH pulse width	1000		ns
$t_{w(UPL)}$	TAiOUT input LOW pulse width	1000		ns
$t_{su(UP-TiN)}$	TAiOUT input setup time	400		ns
$t_{h(TiN-UP)}$	TAiOUT input hold time	400		ns

Timing requirements(referenced to $V_{CC} = 3.3V$, $V_{SS} = 0V$, at $T_{opr} = -20^{\circ}C$ to $85^{\circ}C$ / $-40^{\circ}C$ to $85^{\circ}C$ (*) unless otherwise specified)* : Specify a product of $-40^{\circ}C$ to $85^{\circ}C$ to use it.**Table 1.26.15. Timer B input (counter input in event counter mode)**

Symbol	Parameter	Standard		Unit
		Min.	Max.	
$t_{c(TB)}$	TB _{IN} input cycle time (counted on one edge)	100		ns
$t_{w(TBH)}$	TB _{IN} input HIGH pulse width (counted on one edge)	40		ns
$t_{w(TBL)}$	TB _{IN} input LOW pulse width (counted on one edge)	40		ns
$t_{c(TB)}$	TB _{IN} input cycle time (counted on both edges)	200		ns
$t_{w(TBH)}$	TB _{IN} input HIGH pulse width (counted on both edges)	80		ns
$t_{w(TBL)}$	TB _{IN} input LOW pulse width (counted on both edges)	80		ns

Table 1.26.16. Timer B input (pulse period measurement mode)

Symbol	Parameter	Standard		Unit
		Min.	Max.	
$t_{c(TB)}$	TB _{IN} input cycle time	400		ns
$t_{w(TBH)}$	TB _{IN} input HIGH pulse width	200		ns
$t_{w(TBL)}$	TB _{IN} input LOW pulse width	200		ns

Table 1.26.17. Timer B input (pulse width measurement mode)

Symbol	Parameter	Standard		Unit
		Min.	Max.	
$t_{c(TB)}$	TB _{IN} input cycle time	400		ns
$t_{w(TBH)}$	TB _{IN} input HIGH pulse width	200		ns
$t_{w(TBL)}$	TB _{IN} input LOW pulse width	200		ns

Table 1.26.18. A-D trigger input

Symbol	Parameter	Standard		Unit
		Min.	Max.	
$t_{c(AD)}$	AD _{TRG} input cycle time (trigger able minimum)	1000		ns
$t_{w(ADL)}$	AD _{TRG} input LOW pulse width	125		ns

Table 1.26.19. Serial I/O

Symbol	Parameter	Standard		Unit
		Min.	Max.	
$t_{c(CK)}$	CLK _i input cycle time	300		ns
$t_{w(CKH)}$	CLK _i input HIGH pulse width	150		ns
$t_{w(CKL)}$	CLK _i input LOW pulse width	150		ns
$t_{d(C-Q)}$	TxD _i output delay time		100	ns
$t_{h(C-Q)}$	TxD _i hold time	0		ns
$t_{su(D-C)}$	RxD _i input setup time	50		ns
$t_{h(C-D)}$	RxD _i input hold time	90		ns

Table 1.26.20. External interrupt \overline{INT}_i inputs

Symbol	Parameter	Standard		Unit
		Min.	Max.	
$t_{w(INH)}$	\overline{INT}_i input HIGH pulse width	250		ns
$t_{w(INL)}$	\overline{INT}_i input LOW pulse width	250		ns

Switching characteristics (referenced to V_{CC} = 3.3V, V_{SS} = 0V at Topr = – 20°C to 85°C / – 40°C to 85°C (Note 3), CM15 = “1” unless otherwise specified)

Table 1.26.21. Memory expansion and microprocessor modes (with no wait)

Symbol	Parameter	Measuring condition	Standard		Unit
			Min.	Max.	
t _d (BCLK-AD)	Address output delay time	Figure 1.26.1		50	ns
t _h (BCLK-AD)	Address output hold time (BCLK standard)		4		ns
t _h (RD-AD)	Address output hold time (RD standard)		0		ns
t _h (WR-AD)	Address output hold time (WR standard)		0		ns
t _d (BCLK-CS)	Chip select output delay time			50	ns
t _h (BCLK-CS)	Chip select output hold time (BCLK standard)		4		ns
t _d (BCLK-ALE)	ALE signal output delay time			40	ns
t _h (BCLK-ALE)	ALE signal output hold time		-4		ns
t _d (BCLK-RD)	RD signal output delay time			40	ns
t _h (BCLK-RD)	RD signal output hold time		0		ns
t _d (BCLK-WR)	WR signal output delay time			40	ns
t _h (BCLK-WR)	WR signal output hold time		0		ns
t _d (BCLK-DB)	Data output delay time (BCLK standard)			50	ns
t _h (BCLK-DB)	Data output hold time (BCLK standard)		4		ns
t _d (DB-WR)	Data output delay time (WR standard)		(Note1)		ns
t _h (WR-DB)	Data output hold time (WR standard)(Note2)		0		ns

Note 1: Calculated according to the BCLK frequency as follows:

$$t_d(\text{DB} - \text{WR}) = \frac{10^9}{f(\text{BCLK}) \times 2} - 50 \quad [\text{ns}]$$

Note 2: This is standard value shows the timing when the output is off, and doesn't show hold time of data bus. Hold time of data bus is different by capacitor volume and pull-up (pull-down) resistance value.

Hold time of data bus is expressed in

$$t = -CR \times \ln(1 - V_{OL} / V_{CC})$$

by a circuit of the right figure.

For example, when V_{OL} = 0.2V_{CC}, C = 30pF, R = 1kΩ, hold time of output “L” level is

$$t = -30\text{pF} \times 1\text{k}\Omega \times \ln(1 - 0.2V_{CC} / V_{CC}) = 6.7\text{ns}.$$

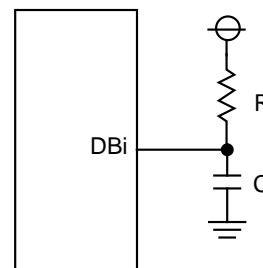

Note 3: Specify a product of -40°C to 85°C to use it.

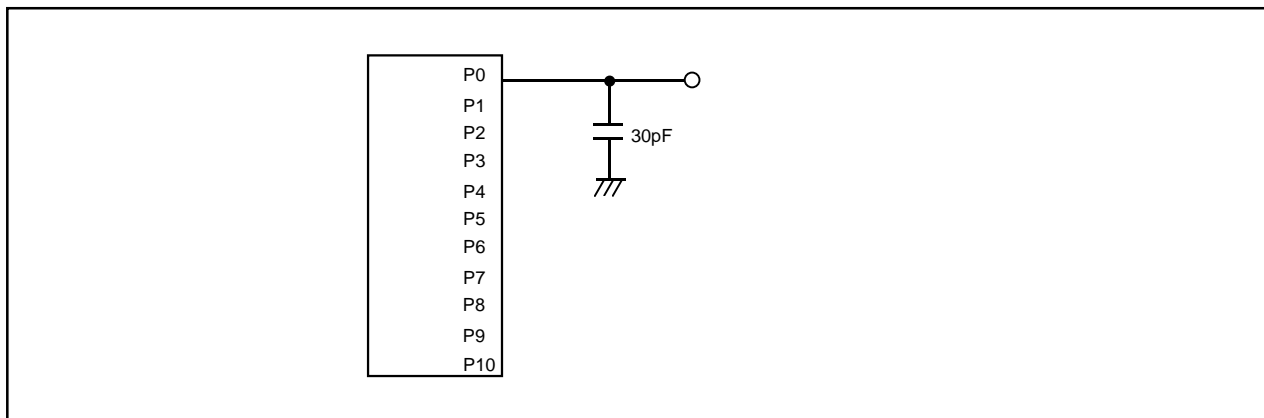

Figure 1.26.1. Port P0 to P10 measurement circuit

Switching characteristics (referenced to $V_{CC} = 3.3V$, $V_{SS} = 0V$ at $T_{opr} = -20^{\circ}C$ to $85^{\circ}C$ / $-40^{\circ}C$ to $85^{\circ}C$ (Note 3), $CM15 = "1"$ unless otherwise specified)

Table 1.26.22. Memory expansion and microprocessor modes
(when accessing external memory area with wait)

Symbol	Parameter	Measuring condition	Standard		Unit
			Min.	Max.	
$t_{d(BCLK-AD)}$	Address output delay time	Figure 1.26.1		50	ns
$t_{h(BCLK-AD)}$	Address output hold time (BCLK standard)		4		ns
$t_{h(RD-AD)}$	Address output hold time (RD standard)		0		ns
$t_{h(WR-AD)}$	Address output hold time (WR standard)		0		ns
$t_{d(BCLK-CS)}$	Chip select output delay time			50	ns
$t_{h(BCLK-CS)}$	Chip select output hold time (BCLK standard)		4		ns
$t_{d(BCLK-ALE)}$	ALE signal output delay time			40	ns
$t_{h(BCLK-ALE)}$	ALE signal output hold time		-4		ns
$t_{d(BCLK-RD)}$	RD signal output delay time			40	ns
$t_{h(BCLK-RD)}$	RD signal output hold time		0		ns
$t_{d(BCLK-WR)}$	WR signal output delay time			40	ns
$t_{h(BCLK-WR)}$	WR signal output hold time		0		ns
$t_{d(BCLK-DB)}$	Data output delay time (BCLK standard)			50	ns
$t_{h(BCLK-DB)}$	Data output hold time (BCLK standard)		4		ns
$t_{d(DB-WR)}$	Data output delay time (WR standard)		(Note1)		ns
$t_{h(WR-DB)}$	Data output hold time (WR standard)(Note2)		0		ns

Note 1: Calculated according to the BCLK frequency as follows:

$$t_{d(DB-WR)} = \frac{10^9}{f(BCLK)} - 50 \quad [ns]$$

Note 2: This is standard value shows the timing when the output is off, and doesn't show hold time of data bus.
Hold time of data bus is different by capacitor volume and pull-up (pull-down) resistance value.

Hold time of data bus is expressed in

$$t = -CR \times \ln(1 - V_{OL} / V_{CC})$$

by a circuit of the right figure.

For example, when $V_{OL} = 0.2V_{CC}$, $C = 30pF$, $R = 1k\Omega$, hold time of output "L" level is

$$t = -30pF \times 1k\Omega \times \ln(1 - 0.2V_{CC} / V_{CC}) = 6.7ns.$$

Note 3: Specify a product of $-40^{\circ}C$ to $85^{\circ}C$ to use it.

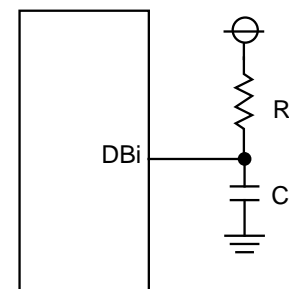

Switching characteristics (referenced to $V_{CC} = 3.3V$, $V_{SS} = 0V$ at $T_{opr} = -20^{\circ}C$ to $85^{\circ}C$ / $-40^{\circ}C$ to $85^{\circ}C$ (Note 2), CM15 = "1" unless otherwise specified)

Table 1.26.23. Memory expansion and microprocessor modes
(when accessing external memory area with wait, and select multiplexed bus)

Symbol	Parameter	Measuring condition	Standard		Unit
			Min.	Max.	
$t_{d(BCLK-AD)}$	Address output delay time	Figure 1.26.1		50	ns
$t_{h(BCLK-AD)}$	Address output hold time (BCLK standard)		4		ns
$t_{h(RD-AD)}$	Address output hold time (RD standard)		(Note1)		ns
$t_{h(WR-AD)}$	Address output hold time (WR standard)		(Note1)		ns
$t_{d(BCLK-CS)}$	Chip select output delay time			50	ns
$t_{h(BCLK-CS)}$	Chip select output hold time (BCLK standard)		4		ns
$t_{h(RD-CS)}$	Chip select output hold time (RD standard)		(Note1)		ns
$t_{h(WR-CS)}$	Chip select output hold time (WR standard)		(Note1)		ns
$t_{d(BCLK-RD)}$	RD signal output delay time			40	ns
$t_{h(BCLK-RD)}$	RD signal output hold time		0		ns
$t_{d(BCLK-WR)}$	WR signal output delay time			40	ns
$t_{h(BCLK-WR)}$	WR signal output hold time		0		ns
$t_{d(BCLK-DB)}$	Data output delay time (BCLK standard)			50	ns
$t_{h(BCLK-DB)}$	Data output hold time (BCLK standard)		4		ns
$t_{d(DB-WR)}$	Data output delay time (WR standard)		(Note1)		ns
$t_{h(WR-DB)}$	Data output hold time (WR standard)		(Note1)		ns
$t_{d(BCLK-ALE)}$	ALE signal output delay time (BCLK standard)			40	ns
$t_{h(BCLK-ALE)}$	ALE signal output hold time (BCLK standard)		-4		ns
$t_{d(AD-ALE)}$	ALE signal output delay time (Address standard)		(Note1)		ns
$t_{h(ALE-AD)}$	ALE signal output hold time (Address standard)		30		ns
$t_{d(AD-RD)}$	Post-address RD signal output delay time	0		ns	
$t_{d(AD-WR)}$	Post-address WR signal output delay time	0		ns	
$t_{dZ(RD-AD)}$	Address output floating start time		8	ns	

Note 1: Calculated according to the BCLK frequency as follows:

$$t_{h(RD-AD)} = \frac{10^9}{f(BCLK) \times 2} + 0 \quad [ns]$$

$$t_{h(WR-AD)} = \frac{10^9}{f(BCLK) \times 2} + 0 \quad [ns]$$

$$t_{h(RD-CS)} = \frac{10^9}{f(BCLK) \times 2} + 0 \quad [ns]$$

$$t_{h(WR-CS)} = \frac{10^9}{f(BCLK) \times 2} + 0 \quad [ns]$$

$$t_{d(DB-WR)} = \frac{10^9 \times 3}{f(BCLK) \times 2} - 50 \quad [ns]$$

$$t_{h(WR-DB)} = \frac{10^9}{f(BCLK) \times 2} + 0 \quad [ns]$$

$$t_{d(AD-ALE)} = \frac{10^9}{f(BCLK) \times 2} - 40 \quad [ns]$$

Note 2: Specify a product of $-40^{\circ}C$ to $85^{\circ}C$ to use it.

Timing

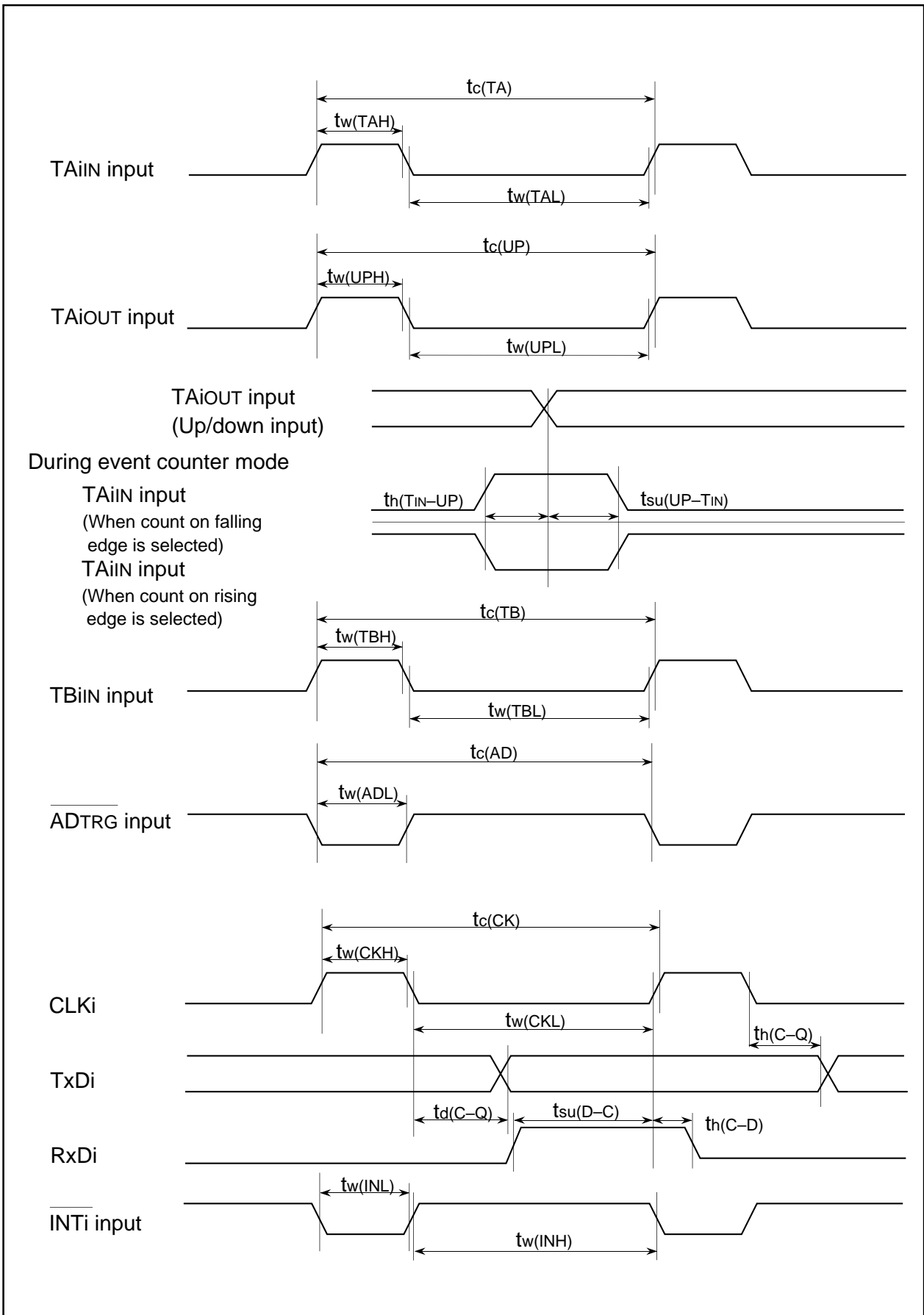
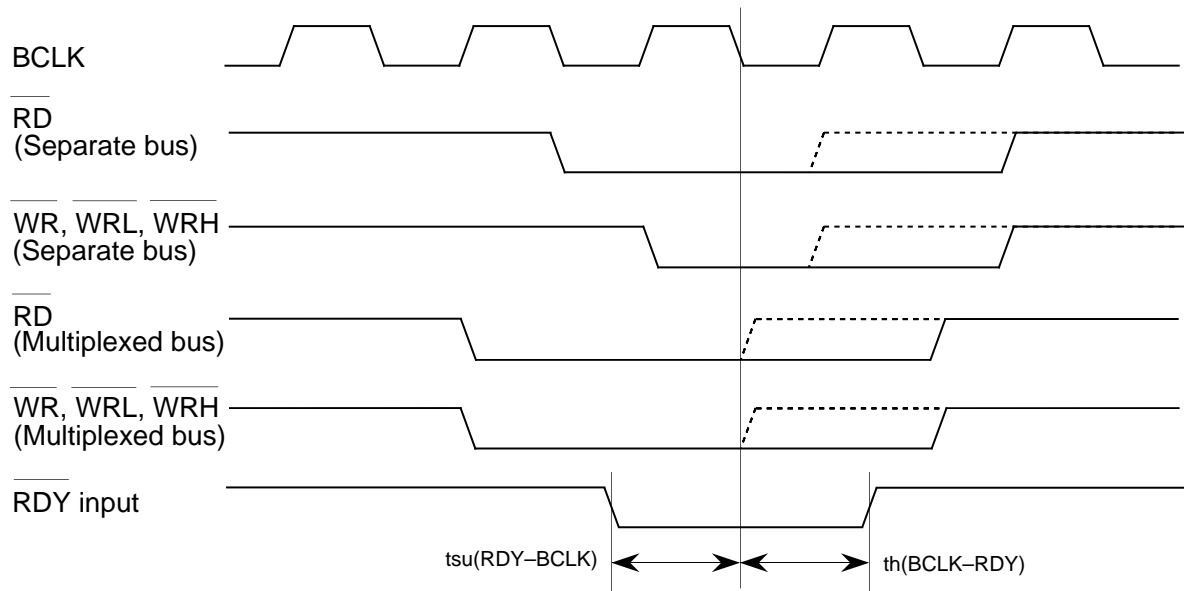
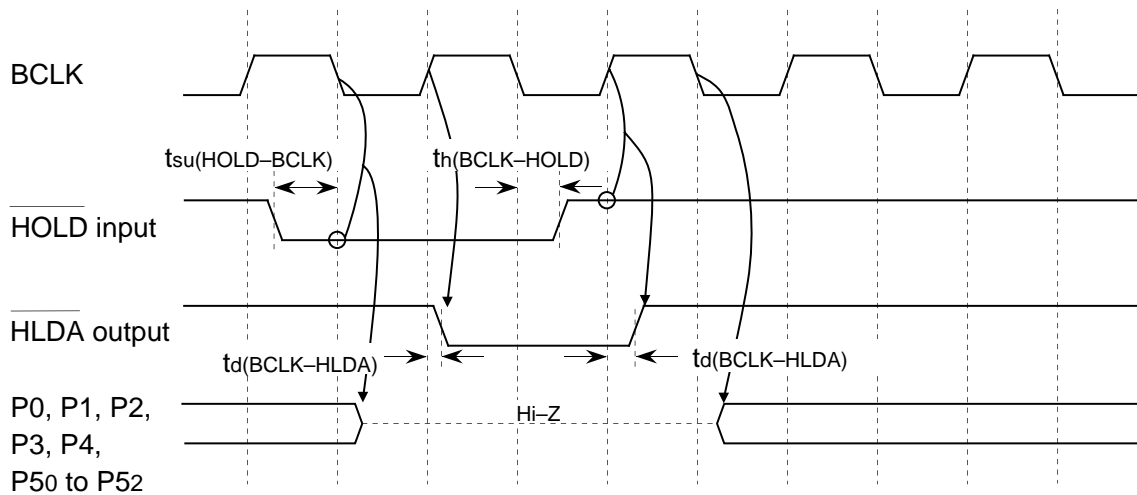

Figure 1.26.2. Timing diagram (1)

Memory Expansion Mode and Microprocessor Mode
 (Valid only with wait)



(Valid with or without wait)



Note: The above pins are set to high-impedance regardless of the input level of the BYTE pin and bit (PM06) of processor mode register 0 selects the function of ports P40 to P43.

Measuring conditions :

- $V_{CC}=3.3V$
- Input timing voltage : Determined with $V_{IL}=0.66V$, $V_{IH}=2.64V$
- Output timing voltage : Determined with $V_{OL}=1.65V$, $V_{OH}=1.65V$

Figure 1.26.3. Timing diagram (2)

**Memory Expansion Mode and Microprocessor Mode
(With no wait)**

Read timing

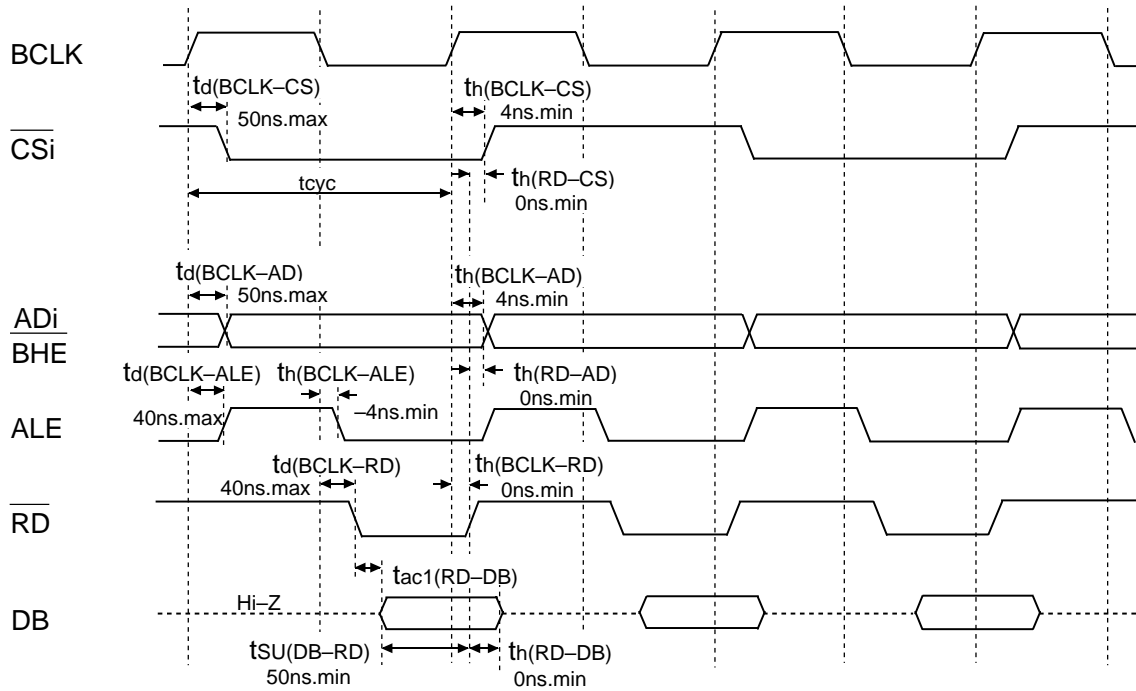

Write timing

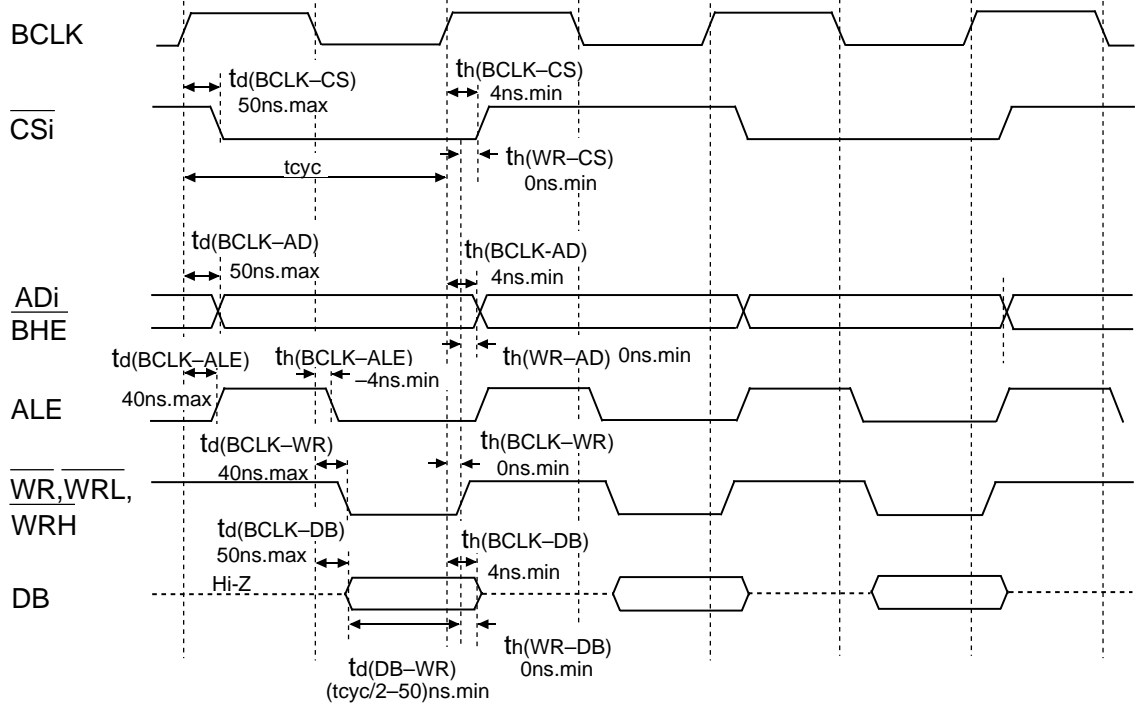
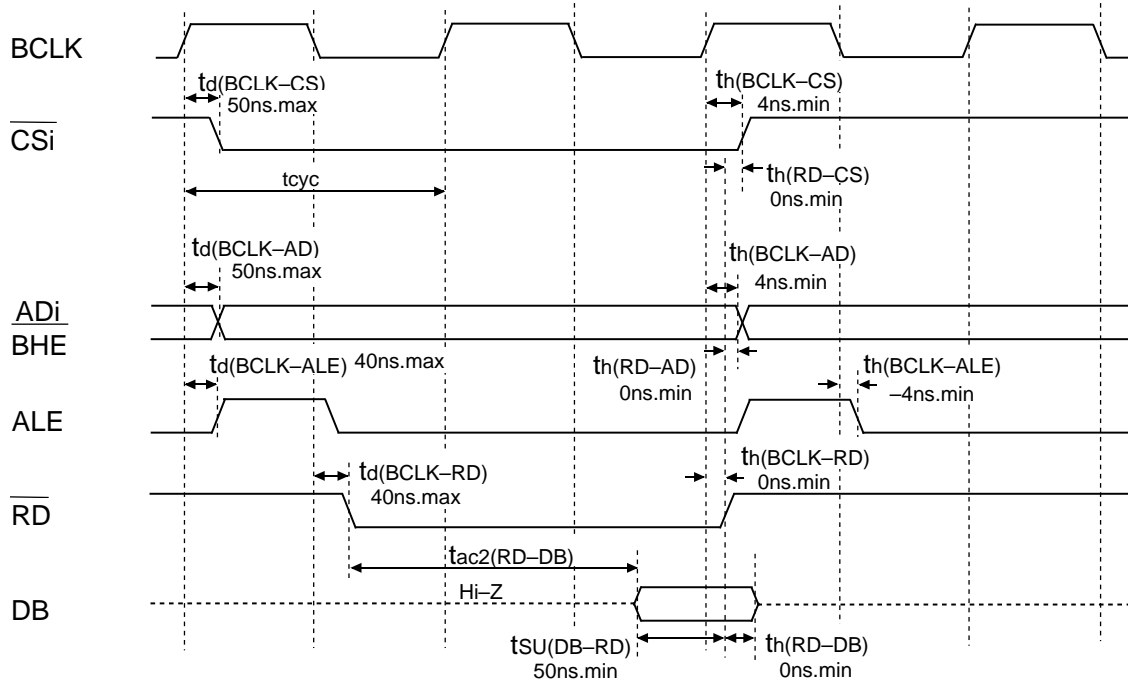

Figure 1.26.4. Timing diagram (3)

Memory Expansion Mode and Microprocessor Mode

(When accessing external memory area with wait)

Read timing



Write timing

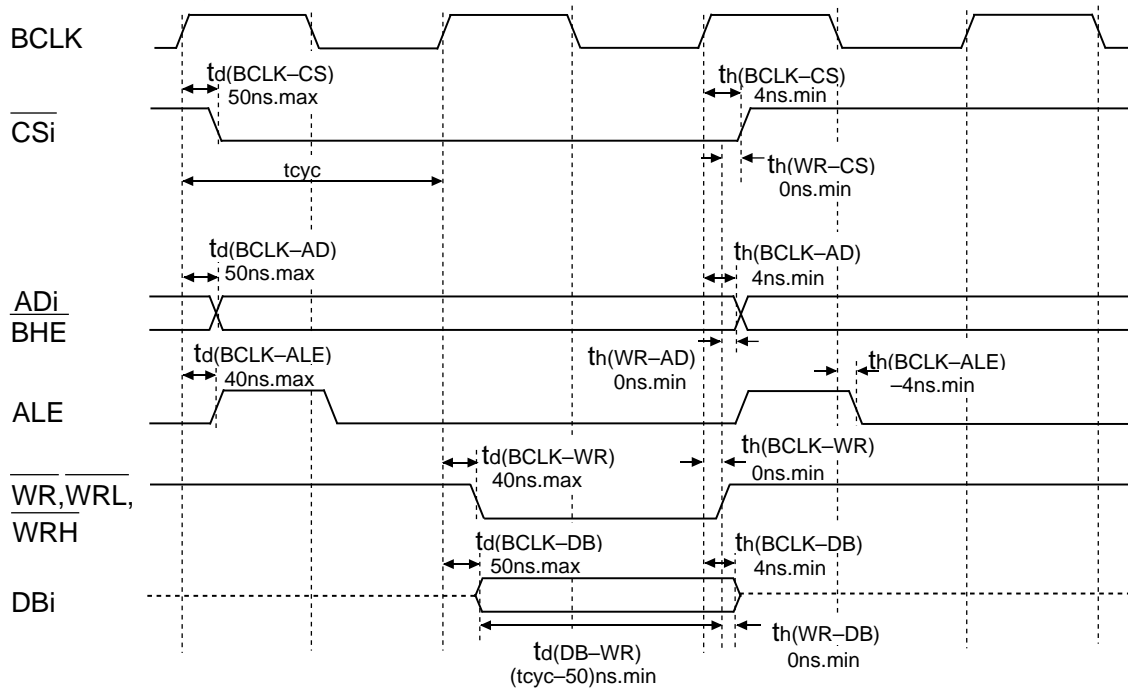

Measuring conditions :

- VCC=3.3V
- Input timing voltage : Determined with: V_{IL}=0.52V, V_{IH}=1.65V
- Output timing voltage : Determined with: V_{OL}=1.65V, V_{OH}=1.65V

Figure 1.26.5. Timing diagram (4)

Outline Performance (Flash Memory Version)

Table 1.28.1 shows the outline performance of the M16C/62N (flash memory version).

Table 1.28.1. Outline performance of the M16C/62N (flash memory version)

Item		Performance
Flash memory operation mode		Three modes (parallel I/O, standard serial I/O, CPU rewrite)
Erase block division	User ROM area	See Figure 1.28.1
	Boot ROM area	One division (4 Kbytes) (Note 1)
Program method		In units of word/byte (Note 2)
Erase method		Collective erase/block erase
Program/erase control method		Program/erase control by software command
Protect method		Protected for each block by lock bit
Number of commands		8 commands
Program/erase count		100 times
Data Retention		10 years
ROM code protect		Parallel I/O and standard serial I/O modes are supported.

Note 1: The boot ROM area contains a standard serial I/O mode control program which is stored in it when shipped from the factory. This area can be erased and programmed in only parallel I/O mode.

Note 2: Can be programmed in byte unit only when using parallel I/O mode.

Description (Flash Memory Version)

Flash Memory

The M16C/62N (flash memory version) contains the flash memory that can be rewritten with a single voltage. For this flash memory, three flash memory modes are available in which to read, program, and erase: parallel I/O and standard serial I/O modes in which the flash memory can be manipulated using a programmer and a CPU rewrite mode in which the flash memory can be manipulated by the Central Processing Unit (CPU). Each mode is detailed in the pages to follow.

The flash memory is divided into several blocks as shown in Figure 1.28.1, so that memory can be erased one block at a time. Each block has a lock bit to enable or disable execution of an erase or program operation, allowing for data in each block to be protected.

In addition to the ordinary user ROM area to store a microcomputer operation control program, the flash memory has a boot ROM area that is used to store a program to control rewriting in CPU rewrite and standard serial I/O modes. This boot ROM area has had a standard serial I/O mode control program stored in it when shipped from the factory. However, the user can write a rewrite control program in this area that suits the user's application system. This boot ROM area can be rewritten in only parallel I/O mode.

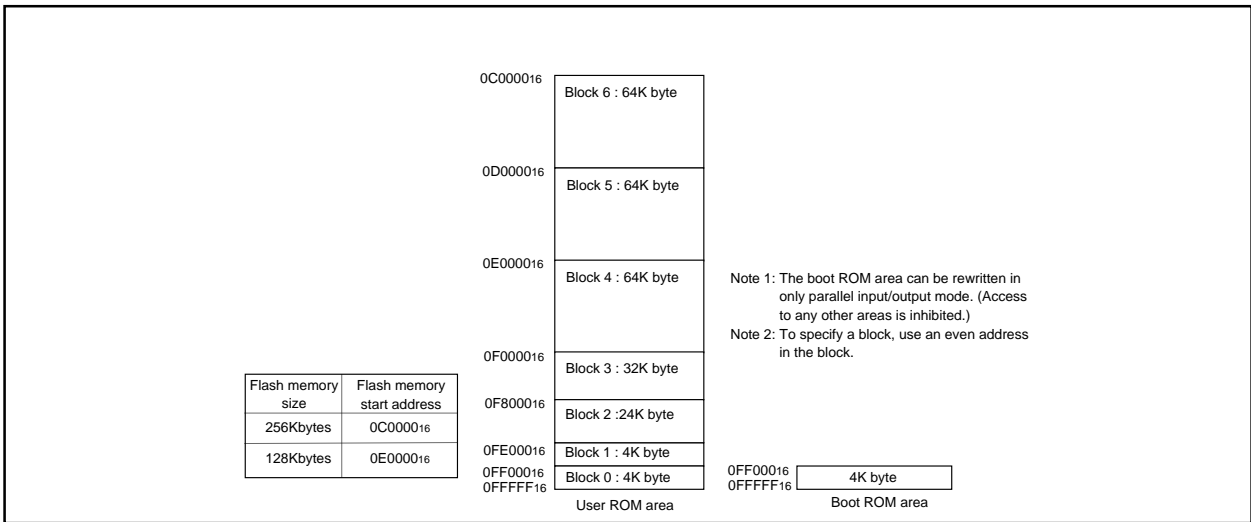

Figure 1.28.1. Block diagram of flash memory version

CPU Rewrite Mode

In CPU rewrite mode, the on-chip flash memory can be operated on (read, program, or erase) under control of the Central Processing Unit (CPU).

In CPU rewrite mode, only the user ROM area shown in Figure 1.28.1 can be rewritten; the boot ROM area cannot be rewritten. Make sure the program and block erase commands are issued for only the user ROM area and each block area.

The control program for CPU rewrite mode can be stored in either user ROM or boot ROM area. In the CPU rewrite mode, because the flash memory cannot be read from the CPU, the rewrite control program must be transferred to any area other than the internal flash memory before it can be executed.

Microcomputer Mode and Boot Mode

The control program for CPU rewrite mode must be written into the user ROM or boot ROM area in parallel I/O mode beforehand. (If the control program is written into the boot ROM area, the standard serial I/O mode becomes unusable.)

See Figure 1.28.1 for details about the boot ROM area.

Normal microcomputer mode is entered when the microcomputer is reset with pulling CNVss pin low. In this case, the CPU starts operating using the control program in the user ROM area.

When the microcomputer is reset by pulling the P55 pin low, the CNVss pin high, and the P50 pin high, the CPU starts operating using the control program in the boot ROM area. This mode is called the "boot" mode. The control program in the boot ROM area can also be used to rewrite the user ROM area (When rewriting the user ROM area in boot mode, bit 5 of the flash memory control register 0 must be set to "1". Write to this bit only when executing out of an area other than the internal flash memory).

Block Address

Block addresses refer to an even address of each block. These addresses are used in the block erase command, lock bit program command, and read lock status command.

Outline Performance (CPU Rewrite Mode)

In the CPU rewrite mode, the CPU erases, programs and reads the internal flash memory as instructed by software commands. Operations must be executed from a memory other than the internal flash memory, such as the internal RAM.

When the CPU rewrite mode select bit (bit 1 at address 03B716) is set to "1", transition to CPU rewrite mode occurs and software commands can be accepted.

In the CPU rewrite mode, write to and read from software commands and data into even-numbered address ("0" for byte address A0) in 16-bit units. Write data into even address in 16-bit units. Do not write 16-bit data into odd address or data in 8-bit units. Always write 8-bit software commands into even-numbered address. Commands are ignored with odd-numbered addresses.

Use software commands to control program and erase operations. Whether a program or erase operation has terminated normally or in error can be verified by reading the status register. Read data from an even address in the user ROM area when reading the status register.

Figure 1.29.1 shows the flash identification register and flash memory control register 0.

Bit 0 of the flash memory control register 0 is the RY/ $\overline{\text{BY}}$ status flag used exclusively to read the operating status of the flash memory. During programming, erase and lock-bit programming operations, it is "0". Otherwise, it is "1".

Bit 1 of the flash memory control register 0 is the CPU rewrite mode select bit. The CPU rewrite mode is entered by setting this bit to "1", so that software commands become acceptable. In CPU rewrite mode, the CPU becomes unable to access the internal flash memory directly. Therefore, Write to this bit only when executing out of an area other than the internal flash memory. Also only when $\overline{\text{NMI}}$ pin is "H" level. To set this bit to "1", it is necessary to write "0" and then write "1" in succession. To set this bit to "0" by only writing a "0".

Bit 2 of the flash memory control register 0 is a lock bit disable select bit. By setting this bit to "1", it is possible to disable erase and write protect (block lock) effectuated by the lock bit data. The lock bit disable select bit only disables the lock bit function; it does not change the lock data bit value. However, if an erase operation is performed when this bit = "1", the lock bit data that is "0" (locked) is set to "1" (unlocked) after erasure. To set this bit to "1", it is necessary to write "0" and then write "1" in succession. This bit can be manipulated only when the CPU rewrite mode select bit = "1".

Bit 3 of the flash memory control register is the flash memory reset bit used to reset the control circuit of the internal flash memory. This bit is used when exiting CPU rewrite mode and when flash memory access has failed. When the CPU rewrite mode select bit is "1", writing "1" for this bit resets the control circuit. To release the reset, it is necessary to set this bit to "0" when RY/ $\overline{\text{BY}}$ status flag is "1". Also when this bit is set to "1", power is not supplied to the internal flash memory, thus power consumption can be reduced. However, in this state, the internal flash memory cannot be accessed. To set this bit to "1", it is necessary to write "0" and then write "1" in succession when the CPU rewrite mode select bit is "1". Use this bit mainly in the low speed mode (when XCIN is the count source of BCLK).

When the CPU is shifted to the stop or wait modes, power to the internal flash memory is automatically shut off. It is reconnected automatically when CPU operation is restored. Therefore, it is not particularly necessary to set flash memory control register 0.

Figure 1.29.2b shows a flowchart for shifting to the low power dissipation mode. Always perform operation as indicated in these flowcharts.

CPU Rewrite Mode (Flash Memory Version)

Bit 5 of the flash memory control register 0 is a user ROM area select bit which is effective in only boot mode. If this bit is set to "1" in boot mode, the area to be accessed is switched from the boot ROM area to the user ROM area. When the CPU rewrite mode needs to be used in boot mode, set this bit to "1". Note that if the microcomputer is booted from the user ROM area, it is always the user ROM area that can be accessed and this bit has no effect. When in boot mode, the function of this bit is effective regardless of whether the CPU rewrite mode is on or off. Write to this bit only when executing out of an area other than the internal flash memory.

Bit 6 of the flash memory control register 0 is the program status flag used exclusively to read the operating status of the auto program operation. If a program error occurs, it is set to "1". Otherwise, it is "0".

Bit 7 of the flash memory control register 0 is the erase status flag used exclusively to read the operating status of the auto erase operation. If an erase error occurs, it is set to "1". Otherwise, it is "0".

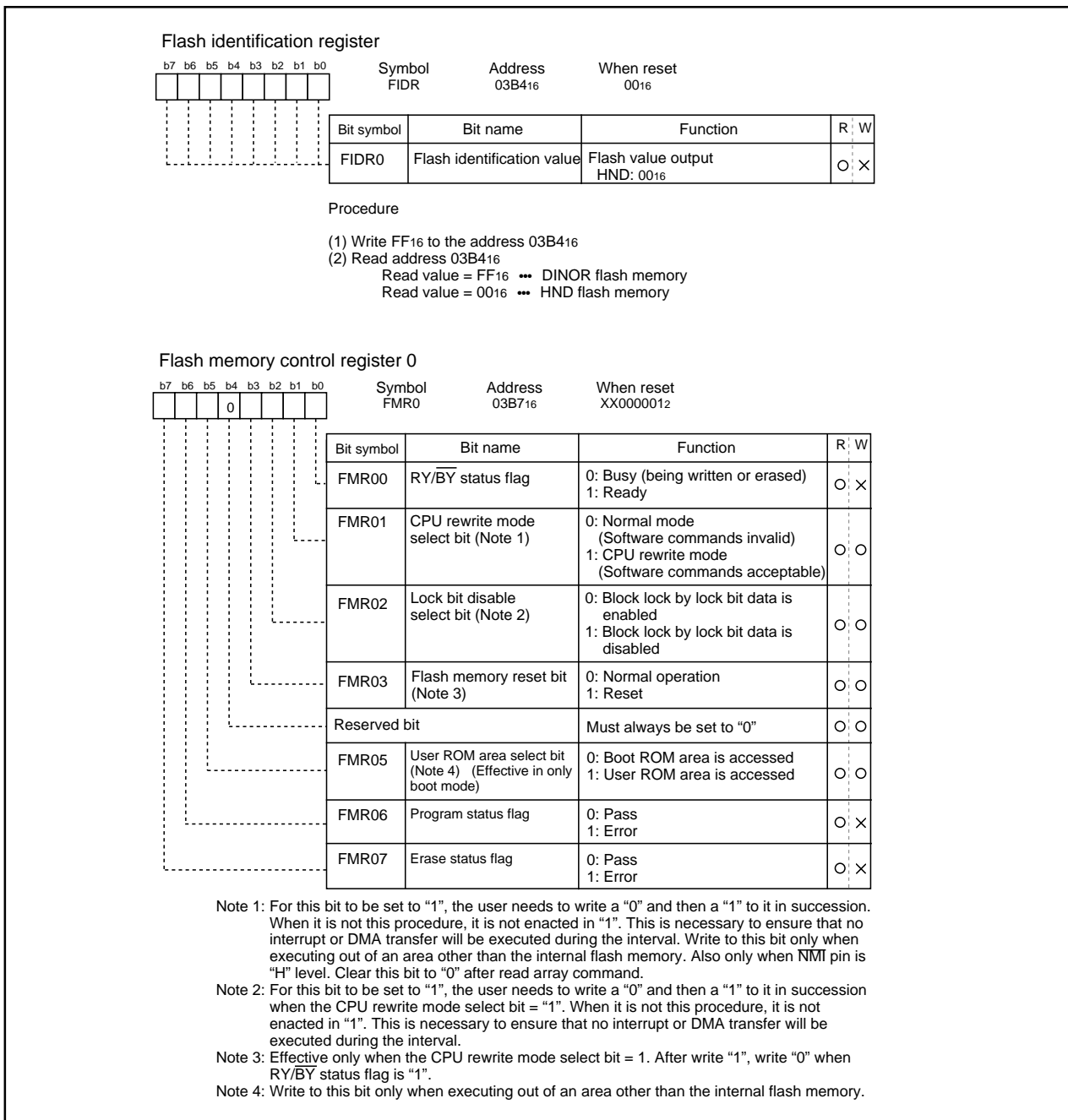

Figure 1.29.1. Flash identification register and flash memory control register 0

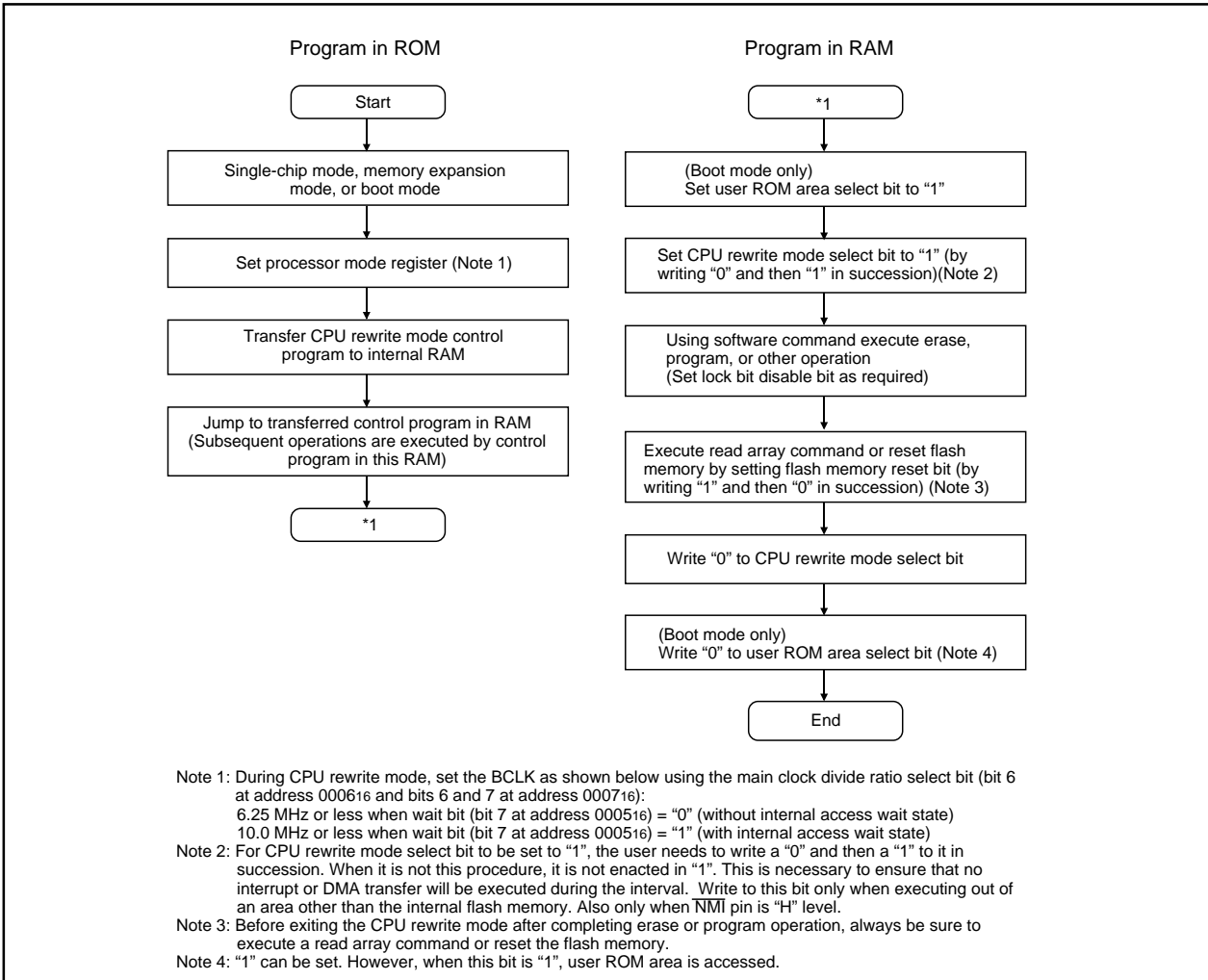

Figure 1.29.2. CPU rewrite mode set/reset flowchart

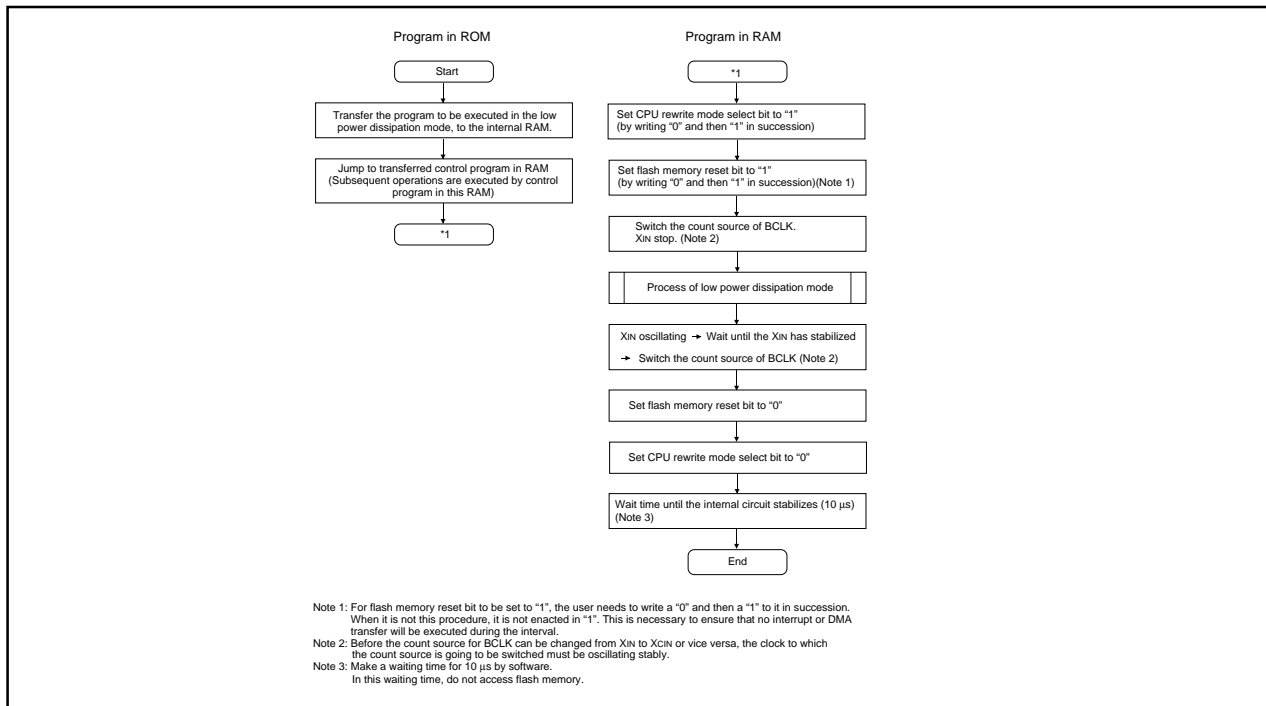

Figure 1.29.2b. Shifting to the low power dissipation mode flowchart

Precautions on CPU Rewrite Mode

Described below are the precautions to be observed when rewriting the flash memory in CPU rewrite mode.

(1) Operation speed

During CPU rewrite mode, set the BCLK as shown below using the main clock divide ratio select bit (bit 6 at address 0006₁₆ and bits 6 and 7 at address 0007₁₆):

6.25 MHz or less when wait bit (bit 7 at address 0005₁₆) = 0 (without internal access wait state)

10.0 MHz or less when wait bit (bit 7 at address 0005₁₆) = 1 (with internal access wait state)

(2) Instructions inhibited against use

The instructions listed below cannot be used during CPU rewrite mode because they refer to the internal data of the flash memory:

UND instruction, INTO instruction, JMPS instruction, JSRS instruction, and BRK instruction

(3) Interrupts inhibited against use

The address match interrupt cannot be used during CPU rewrite mode because they refer to the internal data of the flash memory. If interrupts have their vector in the variable vector table, they can be used by transferring the vector into the RAM area. The $\overline{\text{NMI}}$ and watchdog timer interrupts can be used to automatically initialize the flash identification register and flash memory control register 0 to "0", then return to normal operation. However, these two interrupts' jump addresses are located in the fixed vector table and there must exist a routine to be executed. Since the rewrite operation is halted when an $\overline{\text{NMI}}$ or watchdog timer interrupts occurs, you must reset the CPU rewrite mode select bit to "1" and then perform the erase/program operation again.

(4) Access disable

Write to CPU rewrite mode select bit and user ROM area select bit only when executing out of an area other than the internal flash memory.

(5) How to access

For CPU rewrite mode select bit and lock bit disable select bit to be set to "1", the user needs to write a "0" and then a "1" to it in succession. When it is not this procedure, it is not enacted in "1". This is necessary to ensure that no interrupt or DMA transfer will be executed during the interval. Write to CPU rewrite mode select bit and user ROM area select bit only when executing out of an area other than the internal flash memory. Also only when $\overline{\text{NMI}}$ pin is "H" level.

(6) Writing in the user ROM area

If power is lost while rewriting blocks that contain the flash rewrite program with the CPU rewrite mode, those blocks may not be correctly rewritten and it is possible that the flash memory can no longer be rewritten after that. Therefore, it is recommended to use the standard serial I/O mode or parallel I/O mode to rewrite these blocks.

(7) Using the lock bit

To use the CPU rewrite mode, use a boot program that can set and cancel the lock command.

(8) Internal reserved area expansion bit (Bit 3 at address 0005₁₆)

To use the products which RAM size is over 15 Kbytes or flash memory size is over 192 Kbytes, change into the CPU rewrite mode after setting the internal reserved area expansion bit (bit 3 at address 0005₁₆) to "1". Even if the CPU rewrite mode select bit (bit 1 at address 03B7₁₆) is set to "1", the internal reserved area expansion bit (bit 3 at address 0005₁₆) is not set to "1" automatically.

Software Commands

Table 1.29.1 lists the software commands available with the M16C/62N (flash memory version).

After setting the CPU rewrite mode select bit to 1, write a software command to specify an erase or program operation. Note that when entering a software command, the upper byte (D8 to D15) is ignored.

The content of each software command is explained below.

Table 1.29.1. List of software commands (CPU rewrite mode)

Command	First bus cycle			Second bus cycle		
	Mode	Address	Data (D ₀ to D ₇)	Mode	Address	Data (D ₀ to D ₇)
Read array	Write	X	FF ₁₆			
Read status register	Write	X	70 ₁₆	Read	X	SRD (Note 2)
Clear status register	Write	X	50 ₁₆			
Program (Note 3)	Write	WA	40 ₁₆	Write	WA (Note 3)	WD (Note 3)
Block erase	Write	X	20 ₁₆	Write	BA (Note 4)	D0 ₁₆
Erase all unlock block	Write	X	A7 ₁₆	Write	X	D0 ₁₆
Lock bit program	Write	BA	77 ₁₆	Write	BA	D0 ₁₆
Read lock bit status	Write	X	71 ₁₆	Read	BA	D ₆ (Note 5)

Note 1: When a software command is input, the high-order byte of data (D₈ to D₁₅) is ignored.

Note 2: SRD = Status Register Data (Set an address to even address in the user ROM area)

Note 3: WA = Write Address (even address), WD = Write Data (16-bit data)

Note 4: BA = Block Address (Enter the maximum address of each block that is an even address.)

Note 5: D₆ corresponds to the block lock status. Block not locked when D₆ = 1, block locked when D₆ = 0.

Note 6: X denotes a given address in the user ROM area (that is an even address).

Read Array Command (FF₁₆)

The read array mode is entered by writing the command code "FF₁₆" in the first bus cycle. When an even address to be read is input in one of the bus cycles that follow, the content of the specified address is read out at the data bus (D₀–D₁₅), 16 bits at a time.

The read array mode is retained intact until another command is written.

However, please begin to read data in the following procedures when a user uses read array command after program command.

- (1) Set FF₁₆, FF₁₆, FF₁₆, FF₁₆ to arbitrary continuing four address beforehand
- (2) Input the top address which FF₁₆ was set at (in read array mode)
- (3) Input the top address till FFFF₁₆ agrees with the value that begins to have been read
- (4) Input top address +2
- (5) Input top address +2 till FFFF₁₆ agrees with the value that begins to have been read
- (6) Input an arbitrary address

Read Status Register Command (70₁₆)

When the command code "70₁₆" is written in the first bus cycle, the content of the status register is read out at the data bus (D₀–D₇) by a read in the second bus cycle (Set an address to even address in the user ROM area).

The status register is explained in the next section.

Clear Status Register Command (50₁₆)

This command is used to clear the bits SR₄ and SR₅ of the status register after they have been set. These bits indicate that operation has ended in an error. To use this command, write the command code "50₁₆" in the first bus cycle.

Program Command (40₁₆)

Program operation starts when the command code "40₁₆" is written in the first bus cycle. Then, if the address and data to program are written in the 2nd bus cycle, program operation (data programming and verification) will start. Make an address in the first bus cycle same as an address to program by the second bus cycle.

Whether the write operation is completed can be confirmed by reading the status register or the RY/ $\overline{\text{BY}}$ status flag. When the program starts, the read status register mode is accessed automatically and the content of the status register is read into the data bus (D0 - D7). The status register bit 7 (SR7) is set to 0 at the same time the write operation starts and is returned to 1 upon completion of the write operation. In this case, the read status register mode remains active until the Read Array command (FF₁₆) is written.

The RY/ $\overline{\text{BY}}$ status flag is 0 during write operation and 1 when the write operation is completed as is the status register bit 7.

At program end, program results can be checked by reading the status register.

Figure 1.29.3 shows an example of a program flowchart.

Each block of the flash memory can be write protected by using a lock bit. For details, refer to the section where the data protect function is detailed.

Additional writes to the already programmed pages are prohibited.

Do a command to use in right after of program command as follows

Make an address in the first bus cycle same as an address to program by the second bus cycle of program command.

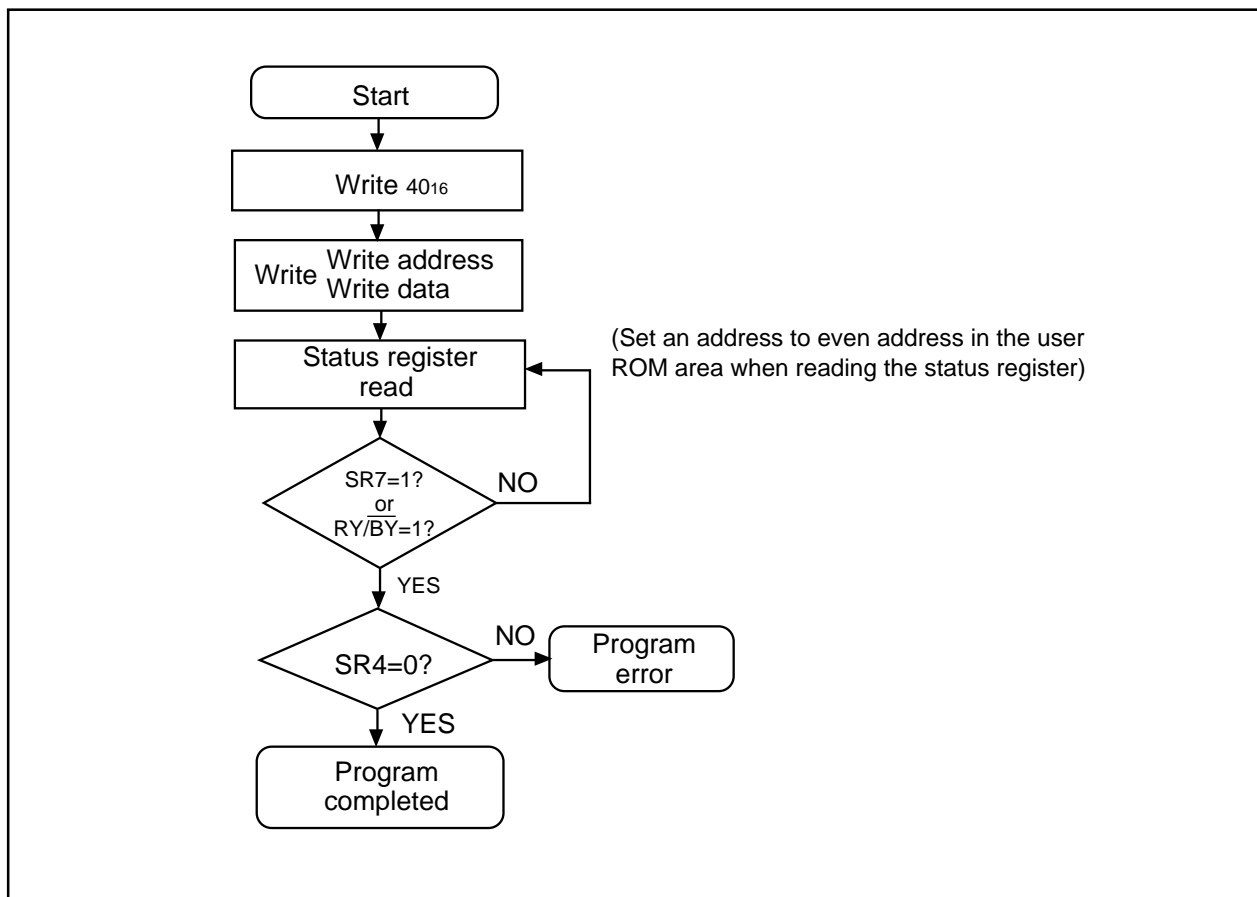

Figure 1.29.3. Program flowchart

Block Erase Command (2016/D016)

By writing the command code "2016" in the first bus cycle and the confirmation command code "D016" in the second bus cycle that follows to the block address of a flash memory block, the system initiates an auto erase (erase and erase verify) operation.

Whether the auto erase operation is completed can be confirmed by reading the status register or the flash memory control register 0. At the same time the auto erase operation starts, the read status register mode is automatically entered, so the content of the status register can be read out. The status register bit 7 (SR7) is set to 0 at the same time the auto erase operation starts and is returned to 1 upon completion of the auto erase operation. In this case, the read status register mode remains active until the Read Array command (FF16) or Read Lock Bit Status command (7116) is written or the flash memory is reset using its reset bit.

The RY/B \bar{Y} status flag of the flash memory control register 0 is 0 during auto erase operation and 1 when the auto erase operation is completed as is the status register bit 7.

After the auto erase operation is completed, the status register can be read out to know the result of the auto erase operation. For details, refer to the section where the status register is detailed.

Figure 1.29.4 shows an example of a block erase flowchart.

Each block of the flash memory can be protected against erasure by using a lock bit. For details, refer to the section where the data protect function is detailed.

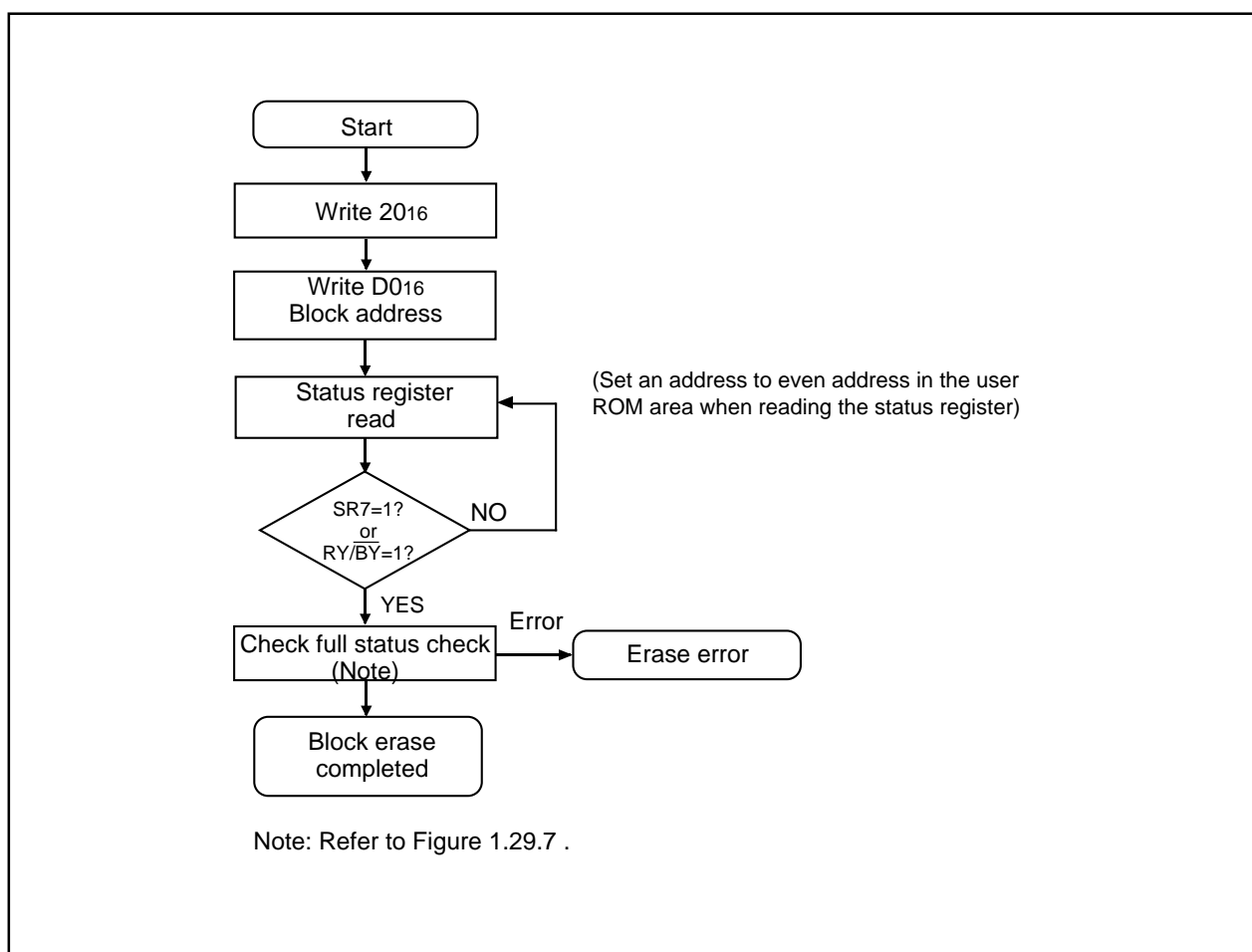

Figure 1.29.4. Block erase flowchart

Erase All Unlock Blocks Command (A716/D016)

By writing the command code "A716" in the first bus cycle and the confirmation command code "D016" in the second bus cycle that follows, the system starts erasing blocks successively.

Whether the erase all unlock blocks command is terminated can be confirmed by reading the status register or the flash memory control register 0, in the same way as for block erase. Also, the status register can be read out to know the result of the auto erase operation.

When the lock bit disable select bit of the flash memory control register 0 = 1, all blocks are erased no matter how the lock bit is set. On the other hand, when the lock bit disable select bit = 0, the function of the lock bit is effective and only nonlocked blocks (where lock bit data = 1) are erased.

Lock Bit Program Command (7716/D016)

By writing the command code "7716" in the first bus cycle and the confirmation command code "D016" in the second bus cycle that follows to the block address of a flash memory block, the system sets the lock bit for the specified block to 0 (locked). Make an address in the first bus cycle same as an address to block by the second bus cycle.

Figure 1.29.5 shows an example of a lock bit program flowchart. The status of the lock bit (lock bit data) can be read out by a read lock bit status command.

Whether the lock bit program command is terminated can be confirmed by reading the status register or the flash memory control register 0, in the same way as for page program.

For details about the function of the lock bit and how to reset the lock bit, refer to the section where the data protect function is detailed.

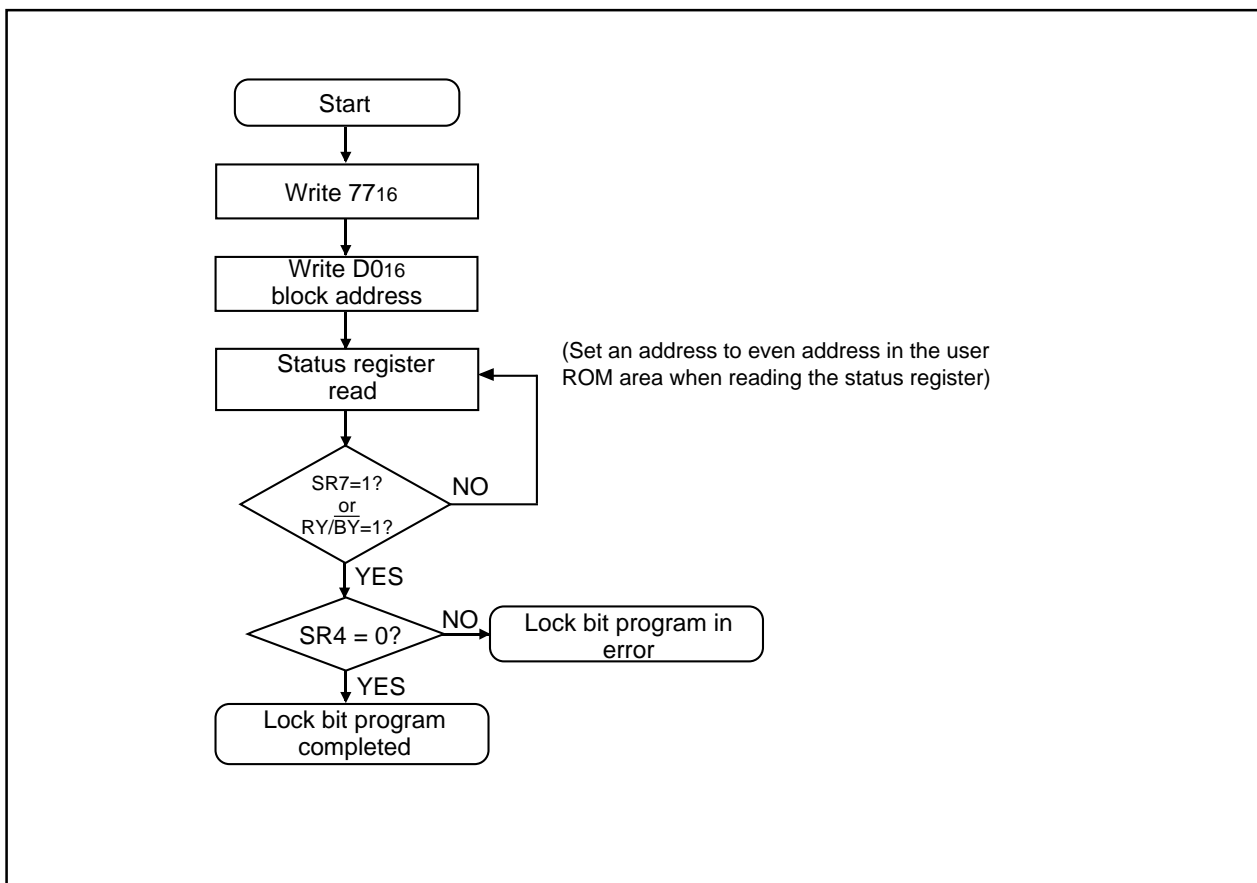

Figure 1.29.5. Lock bit program flowchart

Read Lock Bit Status Command (7116)

By writing the command code "7116" in the first bus cycle and then the block address of a flash memory block in the second bus cycle that follows, the system reads out the status of the lock bit of the specified block on to the data bus(D6).

Figure 1.29.6 shows an example of a read lock bit program flowchart.

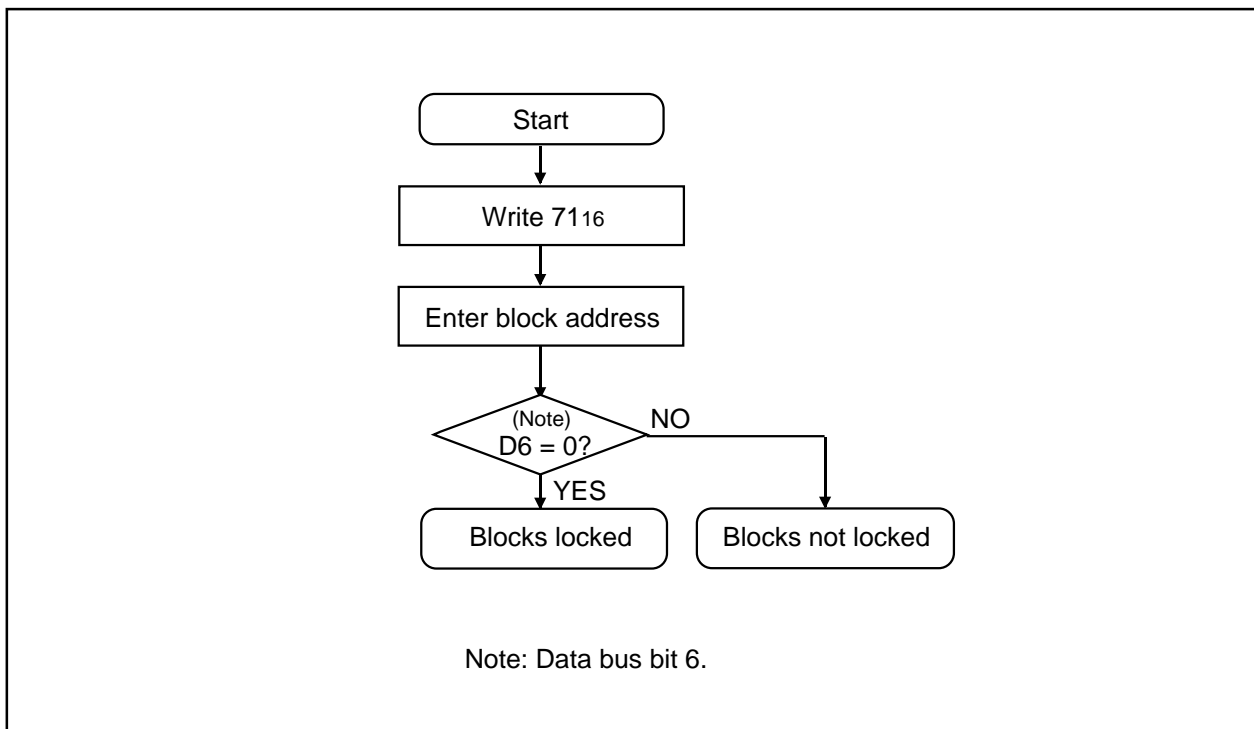

Figure 1.29.6. Read lock bit status flowchart

Data Protect Function (Block Lock)

Each block in Figure 1.28.1 has a nonvolatile lock bit to specify that the block be protected (locked) against erase/write. The lock bit program command is used to set the lock bit to 0 (locked). The lock bit of each block can be read out using the read lock bit status command.

Whether block lock is enabled or disabled is determined by the status of the lock bit and how the flash memory control register 0's lock bit disable select bit is set.

- (1) When the lock bit disable select bit = "0", a specified block can be locked or unlocked by the lock bit status (lock bit data). Blocks whose lock bit data = 0 are locked, so they are disabled against erase/write. On the other hand, the blocks whose lock bit data = "1" are not locked, so they are enabled for erase/write.
- (2) When the lock bit disable select bit = 1, all blocks are nonlocked regardless of the lock bit data, so they are enabled for erase/write. In this case, the lock bit data that is "0" (locked) is set to "1" (nonlocked) after erasure, so that the lock bit-actuated lock is removed.

Status Register

The status register shows the operating state of the flash memory and whether erase operations and programs ended successfully or in error. It can be read in the following ways.

- (1) By reading an arbitrary even address from the user ROM area after writing the read status register command (70₁₆)
- (2) By reading an arbitrary even address from the user ROM area in the period from when the program starts or erase operation starts to when the read array command (FF₁₆) is input

Table 1.29.2 shows the status register.

Also, the status register can be cleared in the following way.

- (1) By writing the clear status register command (50₁₆)

After a reset, the status register is set to "80₁₆".

Each bit in this register is explained below.

Sequencer status (SR7)

After power-on, the sequencer status is set to 1 (ready).

The sequencer status indicates the operating status of the device. This status bit is set to "0" (busy) during write or erase operation and is set to "1" upon completion of these operations.

Erase status (SR5)

The erase status informs the operating status of erase operation to the CPU. When an erase error occurs, it is set to "1".

The erase status is reset to "0" when cleared.

Program status (SR4)

The program status informs the operating status of write operation to the CPU. When a write error occurs, it is set to "1".

The program status is reset to "0" when cleared.

When an erase command is in error (which occurs if the command entered after the block erase command (20₁₆) is not the confirmation command (D0₁₆), both the program status and erase status (SR5) are set to "1".

When the program status or erase status = "1", only the following flash commands will be accepted: Read Array, Read Status Register, and Clear Status Register.

Also, in one of the following cases, both SR4 and SR5 are set to 1 (command sequence error):

- (1) When the valid command is not entered correctly
- (2) When the data entered in the second bus cycle of lock bit program (77₁₆/D0₁₆), block erase (20₁₆/D0₁₆), or erase all unlock blocks (A7₁₆/D0₁₆) is not the D0₁₆ or FF₁₆. However, if FF₁₆ is entered, read array is assumed and the command that has been set up in the first bus cycle is canceled.

Table 1.29.2. Definition of each bit in status register

Each bit of SRD	Status name	Definition	
		"1"	"0"
SR7 (bit7)	Sequencer status	Ready	Busy
SR6 (bit6)	Reserved	-	-
SR5 (bit5)	Erase status	Terminated in error	Terminated normally
SR4 (bit4)	Program status	Terminated in error	Terminated normally
SR3 (bit3)	Reserved	-	-
SR2 (bit2)	Reserved	-	-
SR1 (bit1)	Reserved	-	-
SR0 (bit0)	Reserved	-	-

Full Status Check

By performing full status check, it is possible to know the execution results of erase and program operations. Figure 1.29.7 shows a full status check flowchart and the action to be taken when each error occurs.

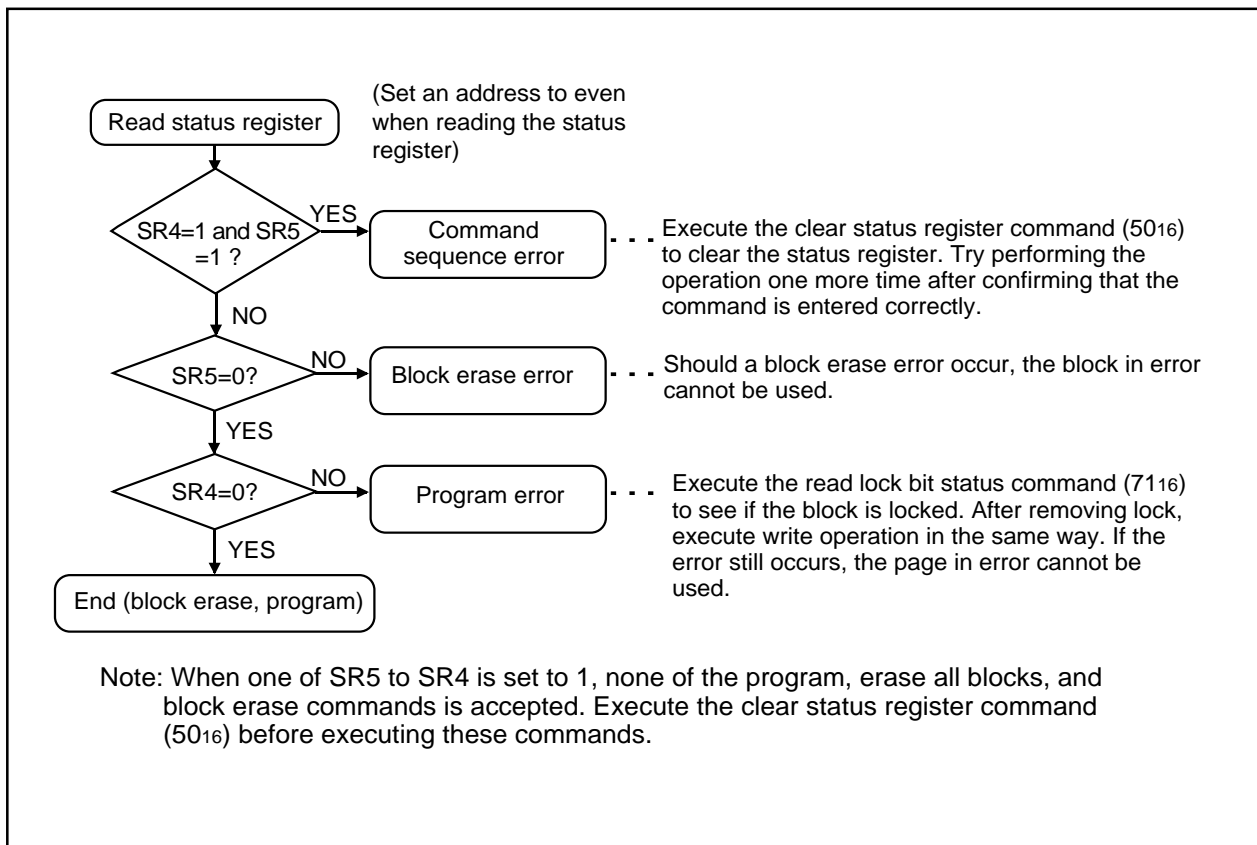

Figure 1.29.7. Full status check flowchart and remedial procedure for errors

Functions To Inhibit Rewriting Flash Memory Version

To prevent the contents of the flash memory version from being read out or rewritten easily, the device incorporates a ROM code protect function for use in parallel I/O mode and an ID code check function for use in standard serial I/O mode.

ROM code protect function

The ROM code protect function is used to prohibit reading out or modifying the contents of the flash memory during parallel I/O mode and is set by using the ROM code protect control address register (0FFFFFF₁₆). Figure 1.30.1 shows the ROM code protect control address (0FFFFFF₁₆). (This address exists in the user ROM area.)

If one of the pair of ROM code protect bits is set to 0, ROM code protect is turned on, so that the contents of the flash memory version are protected against readout and modification.

If both of the two ROM code protect reset bits are set to "00," ROM code protect is turned off, so that the contents of the flash memory version can be read out or modified. Once ROM code protect is turned on, the contents of the ROM code protect reset bits cannot be modified in parallel I/O mode. Use the serial I/O or some other mode to rewrite the contents of the ROM code protect reset bits.

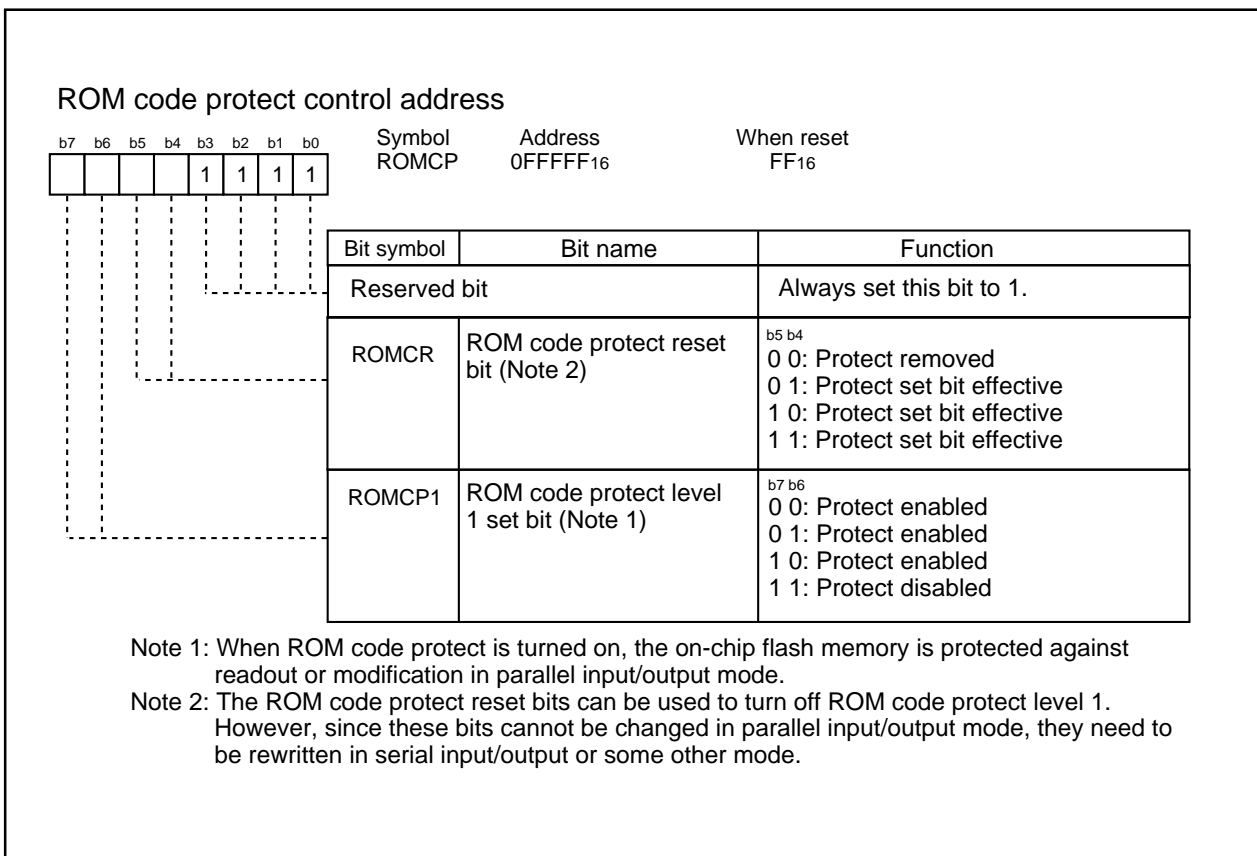

Figure 1.30.1. ROM code protect control address

ID Code Check Function

Use this function in standard serial I/O mode. When the contents of the flash memory are not blank, the ID code sent from the peripheral unit is compared with the ID code written in the flash memory to see if they match. If the ID codes do not match, the commands sent from the peripheral unit are not accepted. The ID code consists of 8-bit data, the areas of which, beginning with the first byte, are 0FFFDF₁₆, 0FFFE3₁₆, 0FFFEB₁₆, 0FFFEF₁₆, 0FFFF3₁₆, 0FFFF7₁₆, and 0FFFFB₁₆. Write a program which has had the ID code preset at these addresses to the flash memory.

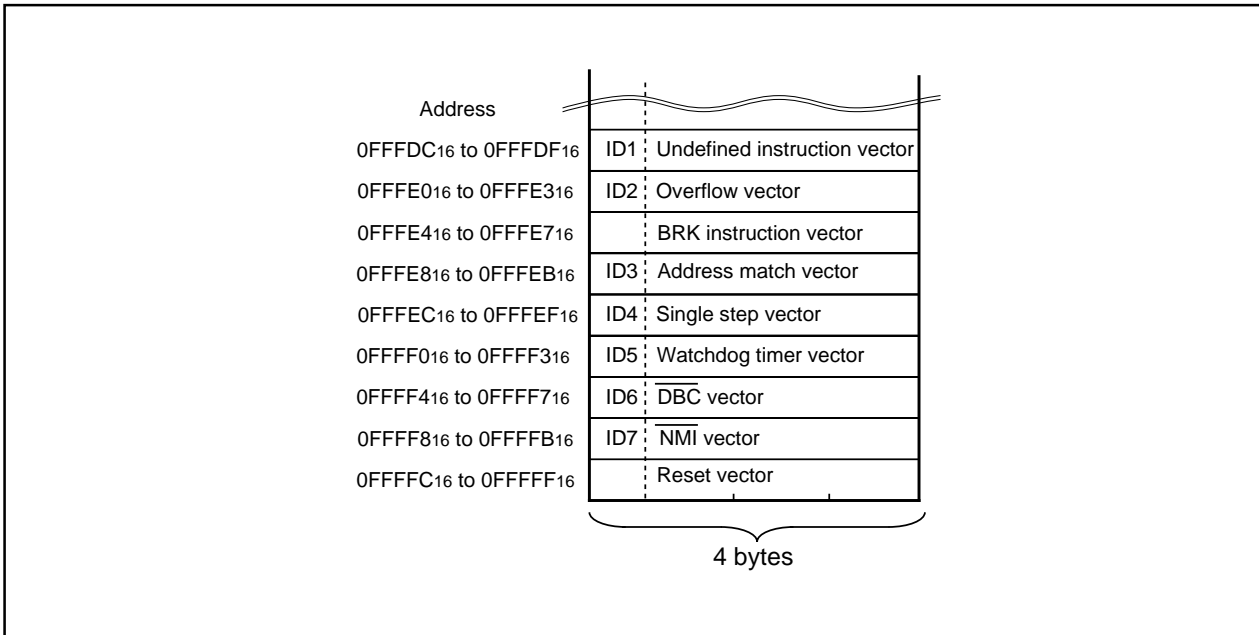

Figure 1.30.2. ID code store addresses

Parallel I/O Mode

The parallel I/O mode inputs and outputs the software commands, addresses and data needed to operate (read, program, erase, etc.) the internal flash memory. This I/O is parallel.

Use an exclusive programmer supporting M16C/62N (flash memory version).

Refer to the instruction manual of each programmer maker for the details of use.

User ROM and Boot ROM Areas

In parallel I/O mode, the user ROM and boot ROM areas shown in Figure 1.28.1 can be rewritten. Both areas of flash memory can be operated on in the same way.

Program and block erase operations can be performed in the user ROM area. The user ROM area and its blocks are shown in Figure 1.28.1.

The boot ROM area is 4 Kbytes in size. In parallel I/O mode, it is located at addresses 0FF000₁₆ through 0FFFFFF₁₆. Make sure program and block erase operations are always performed within this address range. (Access to any location outside this address range is prohibited.)

In the boot ROM area, an erase block operation is applied to only one 4 Kbyte block. The boot ROM area has had a standard serial I/O mode control program stored in it when shipped from the Mitsubishi factory. Therefore, using the device in standard serial input/output mode, you do not need to write to the boot ROM area.

Pin functions (Flash memory standard serial I/O mode)

Pin	Name	I/O	Description
Vcc,Vss	Power input		Apply program/erase protection voltage to Vcc pin and 0 V to Vss pin.
CNVss	CNVss	I	Connect to Vcc pin.
RESET	Reset input	I	Reset input pin. While reset is "L" level, a 20 cycle or longer clock must be input to XIN pin.
XIN	Clock input	I	Connect a ceramic resonator or crystal oscillator between XIN and XOUT pins. To input an externally generated clock, input it to XIN pin and open XOUT pin.
XOUT	Clock output	O	
BYTE	BYTE	I	Connect this pin to Vcc or Vss.
AVcc, AVSS	Analog power supply input		Connect AVss to Vss and AVcc to Vcc, respectively.
VREF	Reference voltage input	I	Enter the reference voltage for AD from this pin.
P00 to P07	Input port P0	I	Input "H" or "L" level signal or open.
P10 to P17	Input port P1	I	Input "H" or "L" level signal or open.
P20 to P27	Input port P2	I	Input "H" or "L" level signal or open.
P30 to P37	Input port P3	I	Input "H" or "L" level signal or open.
P40 to P47	Input port P4	I	Input "H" or "L" level signal or open.
P51 to P54, P56, P57	Input port P5	I	Input "H" or "L" level signal or open.
P50	$\overline{\text{CE}}$ input	I	Input "H" level signal.
P55	$\overline{\text{EPM}}$ input	I	Input "L" level signal.
P60 to P63	Input port P6	I	Input "H" or "L" level signal or open.
P64	BUSY output	O	Standard serial I/O mode 1: BUSY signal output pin Standard serial I/O mode 2: Monitors the boot program operation check signal output pin.
P65	SCLK input	I	Standard serial I/O mode 1: Serial clock input pin Standard serial I/O mode 2: Input "L".
P66	RxD input	I	Serial data input pin
P67	TxD output	O	Serial data output pin
P70 to P77	Input port P7	I	Input "H" or "L" level signal or open.
P80 to P84, P86, P87	Input port P8	I	Input "H" or "L" level signal or open.
P85	$\overline{\text{NMI}}$ input	I	Connect this pin to Vcc.
P90 to P97	Input port P9	I	Input "H" or "L" level signal or open.
P100 to P107	Input port P10	I	Input "H" or "L" level signal or open.

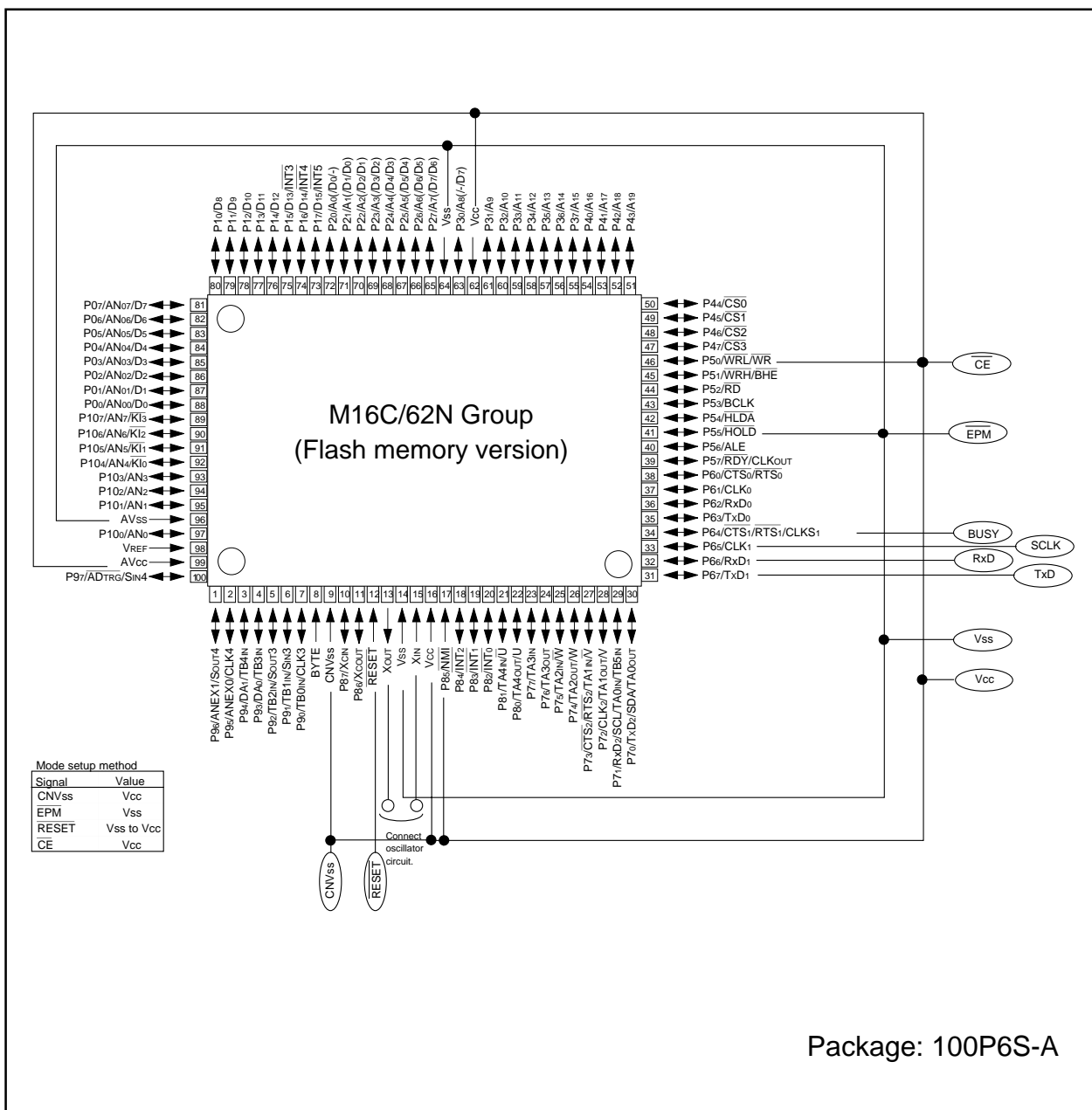

Figure 1.32.1. Pin connections for serial I/O mode

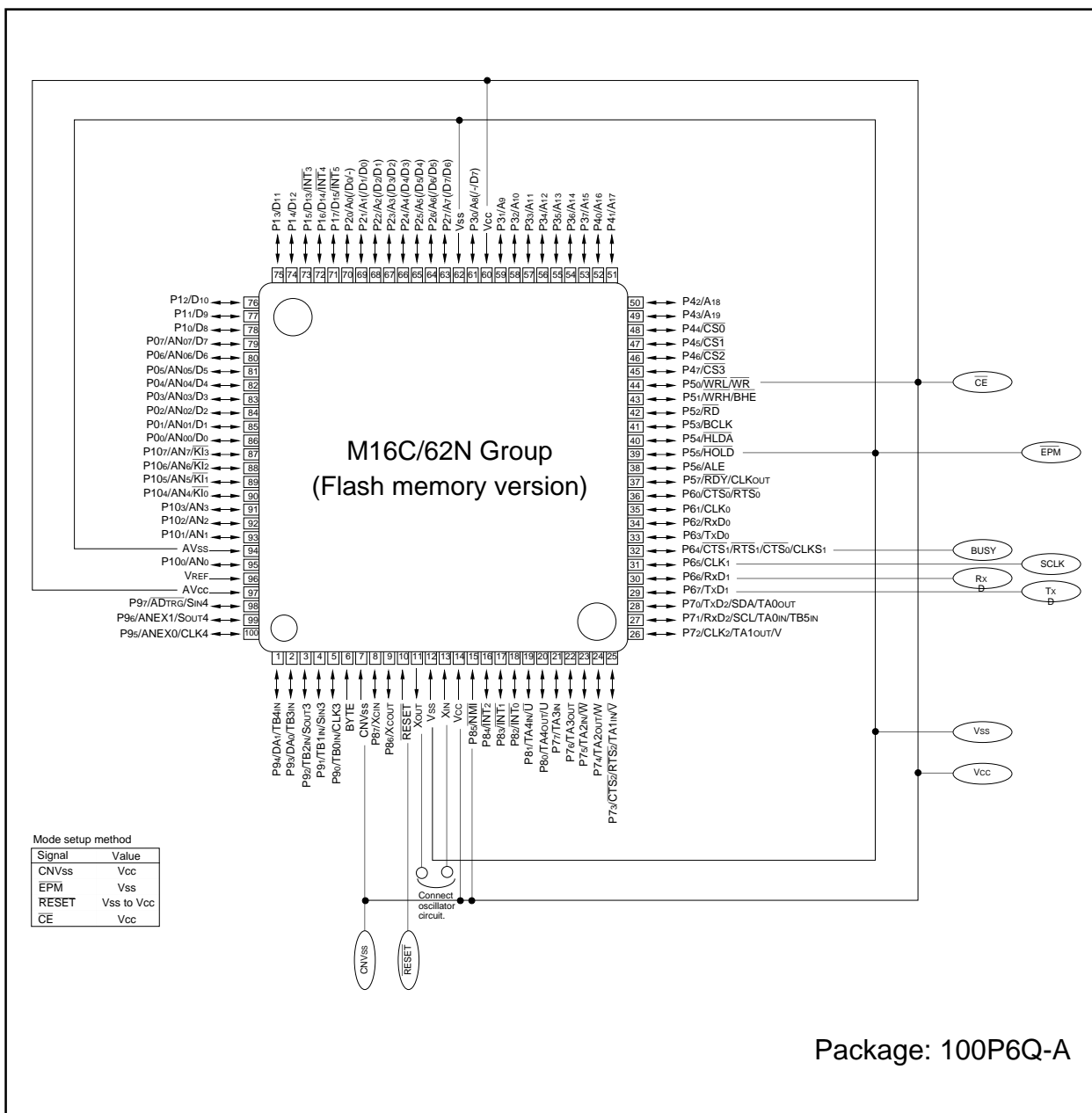

Figure 1.32.1. Pin connections for serial I/O mode (2)

Standard serial I/O mode

The standard serial I/O mode inputs and outputs the software commands, addresses and data needed to operate (read, program, erase, etc.) the internal flash memory. This I/O is serial. There are actually two standard serial I/O modes: mode 1, which is clock synchronized, and mode 2, which is asynchronous. Both modes require a purpose-specific peripheral unit.

The standard serial I/O mode is different from the parallel I/O mode in that the CPU controls flash memory rewrite (uses the CPU's rewrite mode), rewrite data input and so forth. It is started when the reset is released, which is done when the P50 (\overline{CE}) pin is "H" level, the P55 (\overline{EPM}) pin "L" level and the CNVss pin "H" level. (In the ordinary command mode, set CNVss pin to "L" level.)

This control program is written in the boot ROM area when the product is shipped from Mitsubishi. Accordingly, make note of the fact that the standard serial I/O mode cannot be used if the boot ROM area is rewritten in the parallel I/O mode. Figure 1.32.1 shows the pin connections for the standard serial I/O mode. Serial data I/O uses UART1 and transfers the data serially in 8-bit units. Standard serial I/O switches between mode 1 (clock synchronized) and mode 2 (clock asynchronous) according to the level of CLK1 pin when the reset is released.

To use standard serial I/O mode 1 (clock synchronized), set the CLK1 pin to "H" level and release the reset. The operation uses the four UART1 pins CLK1, RxD1, TxD1 and RTS1 (BUSY). The CLK1 pin is the transfer clock input pin through which an external transfer clock is input. The TxD1 pin is for CMOS output. The RTS1 (BUSY) pin outputs an "L" level when ready for reception and an "H" level when reception starts.

To use standard serial I/O mode 2 (clock asynchronous), set the CLK1 pin to "L" level and release the reset. The operation uses the two UART1 pins RxD1 and TxD1.

In the standard serial I/O mode, only the user ROM area indicated in Figure 1.32.18 can be rewritten. The boot ROM cannot.

In the standard serial I/O mode, a 7-byte ID code is used. When there is data in the flash memory, commands sent from the peripheral unit are not accepted unless the ID code matches.

Overview of standard serial I/O mode 1 (clock synchronized)

In standard serial I/O mode 1, software commands, addresses and data are input and output between the MCU and peripheral units (serial programmer, etc.) using 4-wire clock-synchronized serial I/O (UART1). Standard serial I/O mode 1 is engaged by releasing the reset with the P65 (CLK1) pin "H" level.

In reception, software commands, addresses and program data are synchronized with the rise of the transfer clock that is input to the CLK1 pin, and are then input to the MCU via the RxD1 pin. In transmission, the read data and status are synchronized with the fall of the transfer clock, and output from the TxD1 pin.

The TxD1 pin is for CMOS output. Transfer is in 8-bit units with LSB first.

When busy, such as during transmission, reception, erasing or program execution, the RTS1 (BUSY) pin is "H" level. Accordingly, always start the next transfer after the RTS1 (BUSY) pin is "L" level.

Also, data and status registers in memory can be read after inputting software commands. Status, such as the operating state of the flash memory or whether a program or erase operation ended successfully or not, can be checked by reading the status register. Here following are explained software commands, status registers, etc.

Software Commands

Table 1.32.1 lists software commands. In the standard serial I/O mode 1, erase operations, programs and reading are controlled by transferring software commands via the RxD1 pin. Software commands are explained here below.

Table 1.32.1. Software commands (Standard serial I/O mode 1)

	Control command	1st byte transfer	2nd byte	3rd byte	4th byte	5th byte	6th byte		When ID is not verified
1	Page read	FF ₁₆	Address (middle)	Address (high)	Data output	Data output	Data output	Data output to 259th byte	Not acceptable
2	Page program	41 ₁₆	Address (middle)	Address (high)	Data input	Data input	Data input	Data input to 259th byte	Not acceptable
3	Block erase	20 ₁₆	Address (middle)	Address (high)	D0 ₁₆				Not acceptable
4	Erase all unlocked blocks	A7 ₁₆	D0 ₁₆						Not acceptable
5	Read status register	70 ₁₆	SRD output	SRD1 output					Acceptable
6	Clear status register	50 ₁₆							Not acceptable
7	Read lock bit status	71 ₁₆	Address (middle)	Address (high)	Lock bit data output				Not acceptable
8	Lock bit program	77 ₁₆	Address (middle)	Address (high)	D0 ₁₆				Not acceptable
9	Lock bit enable	7A ₁₆							Not acceptable
10	Lock bit disable	75 ₁₆							Not acceptable
11	ID check function	F5 ₁₆	Address (low)	Address (middle)	Address (high)	ID size	ID1	To ID7	Acceptable
12	Download function	FA ₁₆	Size (low)	Size (high)	Check-sum	Data input	To required number of times		Not acceptable
13	Version data output function	FB ₁₆	Version data output	Version data output	Version data output	Version data output	Version data output	Version data output to 9th byte	Acceptable
14	Boot ROM area output function	FC ₁₆	Address (middle)	Address (high)	Data output	Data output	Data output	Data output to 259th byte	Not acceptable
15	Read check data	FD ₁₆	Check data (low)	Check data (high)					Not acceptable

Note 1: Shading indicates transfer from flash memory microcomputer to peripheral unit. All other data is transferred from the peripheral unit to the flash memory microcomputer.

Note 2: SRD refers to status register data. SRD1 refers to status register 1 data.

Note 3: All commands can be accepted when the flash memory is totally blank.

Page Read Command

This command reads the specified page (256 bytes) in the flash memory sequentially one byte at a time. Execute the page read command as explained here following.

- (1) Transfer the "FF16" command code with the 1st byte.
- (2) Transfer addresses A8 to A15 and A16 to A23 with the 2nd and 3rd bytes respectively.
- (3) From the 4th byte onward, data (D0–D7) for the page (256 bytes) specified with addresses A8 to A23 will be output sequentially from the smallest address first in sync with the fall of the clock.

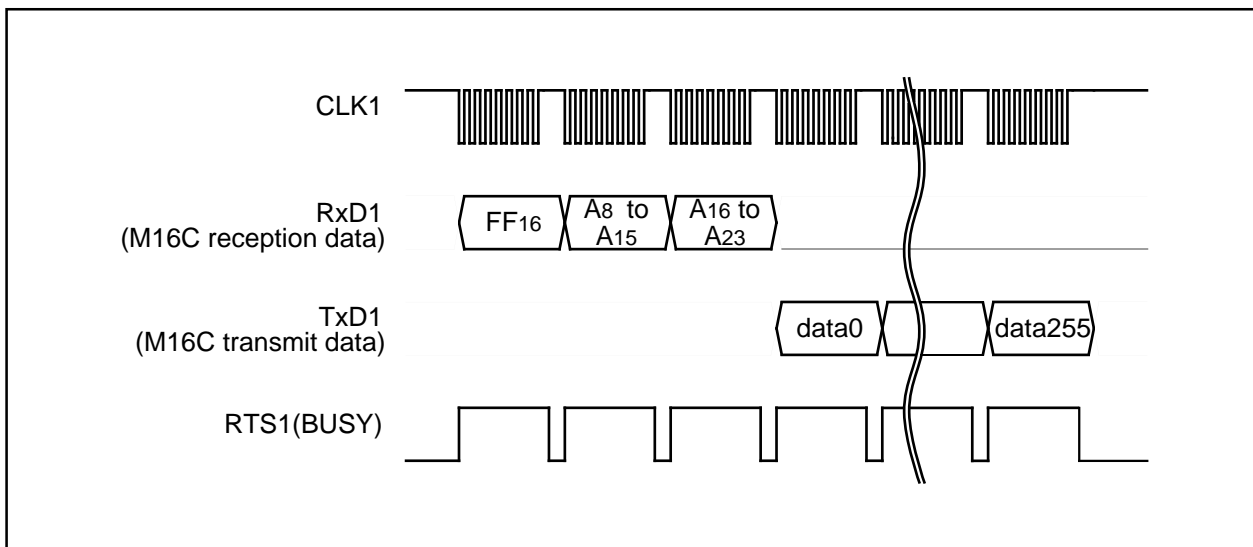

Figure 1.32.2. Timing for page read

Read Status Register Command

This command reads status information. When the "7016" command code is sent with the 1st byte, the contents of the status register (SRD) specified with the 2nd byte and the contents of status register 1 (SRD1) specified with the 3rd byte are read.

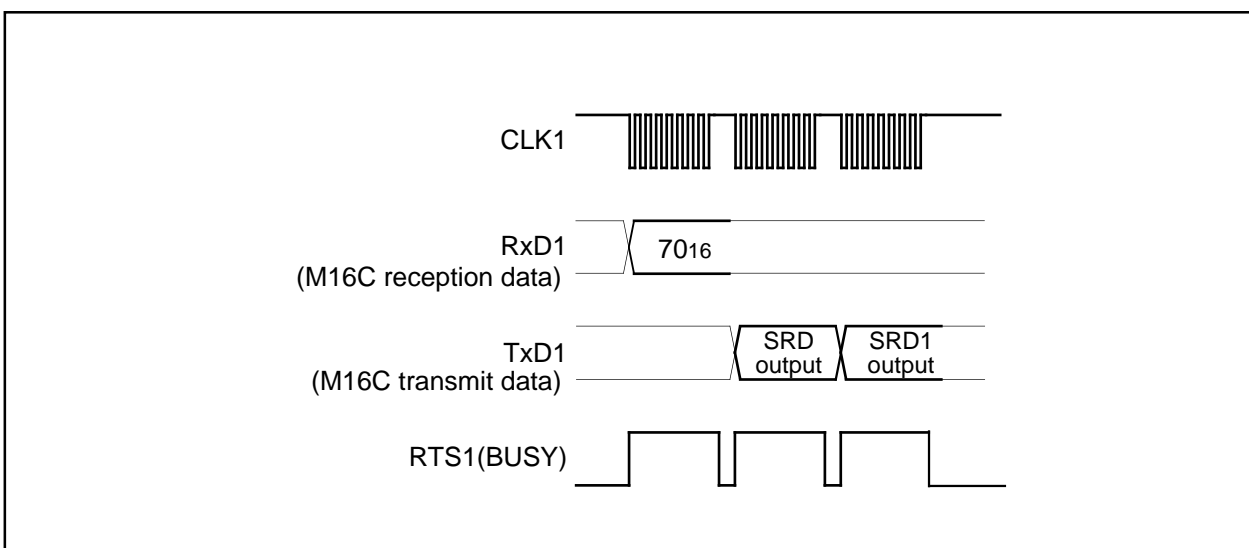

Figure 1.32.3. Timing for reading the status register

Clear Status Register Command

This command clears the bits (SR4, SR5) which are set when the status register operation ends in error. When the "5016" command code is sent with the 1st byte, the aforementioned bits are cleared. When the clear status register operation ends, the RTS1 (BUSY) signal changes from the "H" to the "L" level.

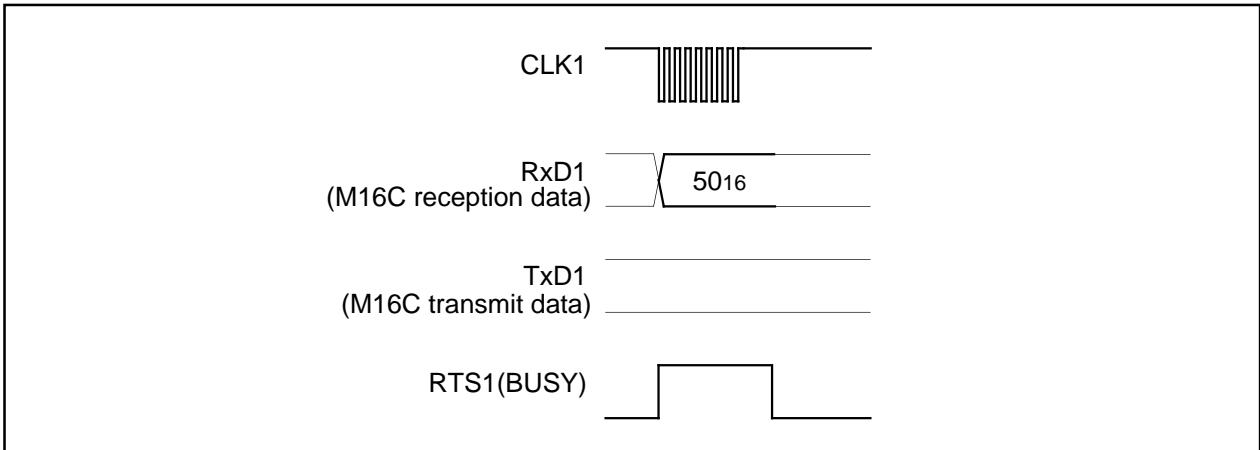

Figure 1.32.4. Timing for clearing the status register

Page Program Command

This command writes the specified page (256 bytes) in the flash memory sequentially one byte at a time. Execute the page program command as explained here following.

- (1) Transfer the "4116" command code with the 1st byte.
- (2) Transfer addresses A8 to A15 and A16 to A23 with the 2nd and 3rd bytes respectively.
- (3) From the 4th byte onward, as write data (D0–D7) for the page (256 bytes) specified with addresses A8 to A23 is input sequentially from the smallest address first, that page is automatically written.

When reception setup for the next 256 bytes ends, the RTS1 (BUSY) signal changes from the "H" to the "L" level. The result of the page program can be known by reading the status register. For more information, see the section on the status register.

Each block can be write-protected with the lock bit. For more information, see the section on the data protection function. Additional writing is not allowed with already programmed pages.

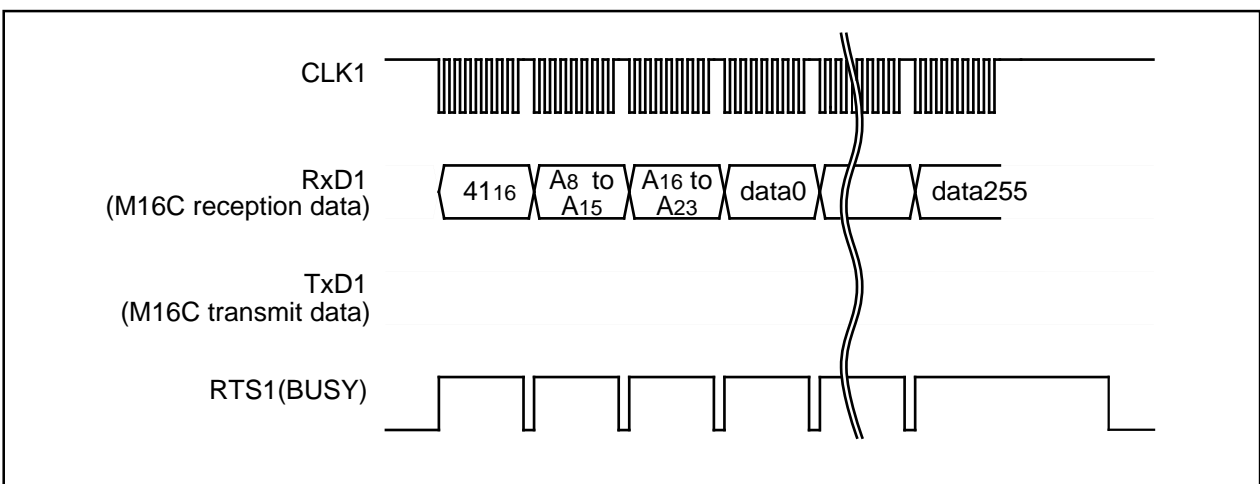

Figure 1.32.5. Timing for the page program

Block Erase Command

This command erases the data in the specified block. Execute the block erase command as explained here following.

- (1) Transfer the "20₁₆" command code with the 1st byte.
- (2) Transfer addresses A₈ to A₁₅ and A₁₆ to A₂₃ with the 2nd and 3rd bytes respectively.
- (3) Transfer the verify command code "D0₁₆" with the 4th byte. With the verify command code, the erase operation will start for the specified block in the flash memory. Write the highest address of the specified block for addresses A₈ to A₂₃.

When block erasing ends, the RTS₁ (BUSY) signal changes from the "H" to the "L" level. After block erase ends, the result of the block erase operation can be known by reading the status register. For more information, see the section on the status register.

Each block can be erase-protected with the lock bit. For more information, see the section on the data protection function.

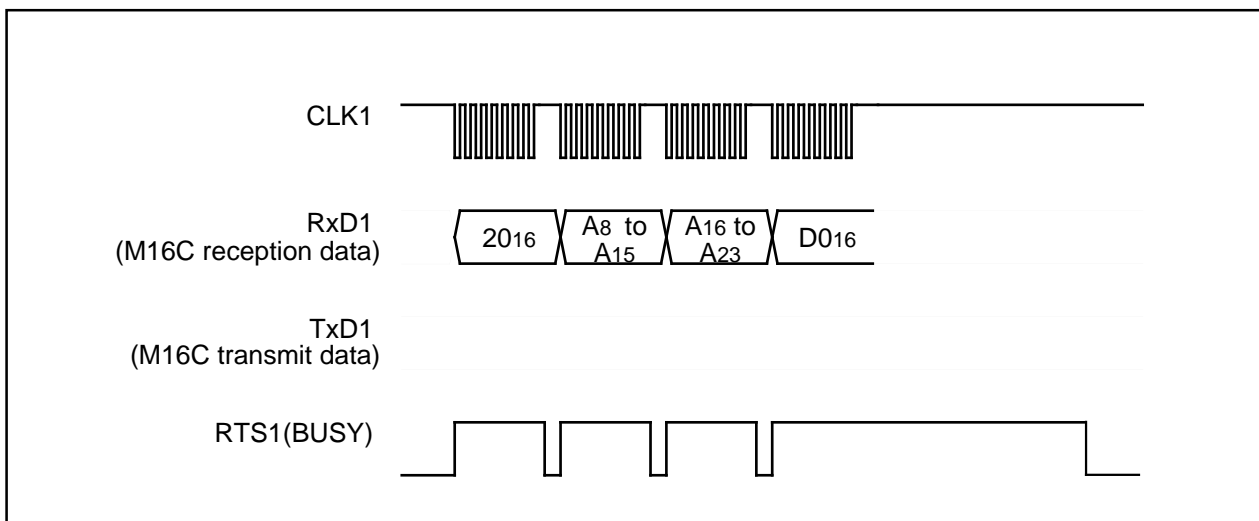

Figure 1.32.6. Timing for block erasing

Erase All Unlocked Blocks Command

This command erases the content of all blocks. Execute the erase all unlocked blocks command as explained here following.

- (1) Transfer the "A7₁₆" command code with the 1st byte.
- (2) Transfer the verify command code "D0₁₆" with the 2nd byte. With the verify command code, the erase operation will start and continue for all blocks in the flash memory.

When block erasing ends, the RTS₁ (BUSY) signal changes from the "H" to the "L" level. The result of the erase operation can be known by reading the status register. Each block can be erase-protected with the lock bit. For more information, see the section on the data protection function.

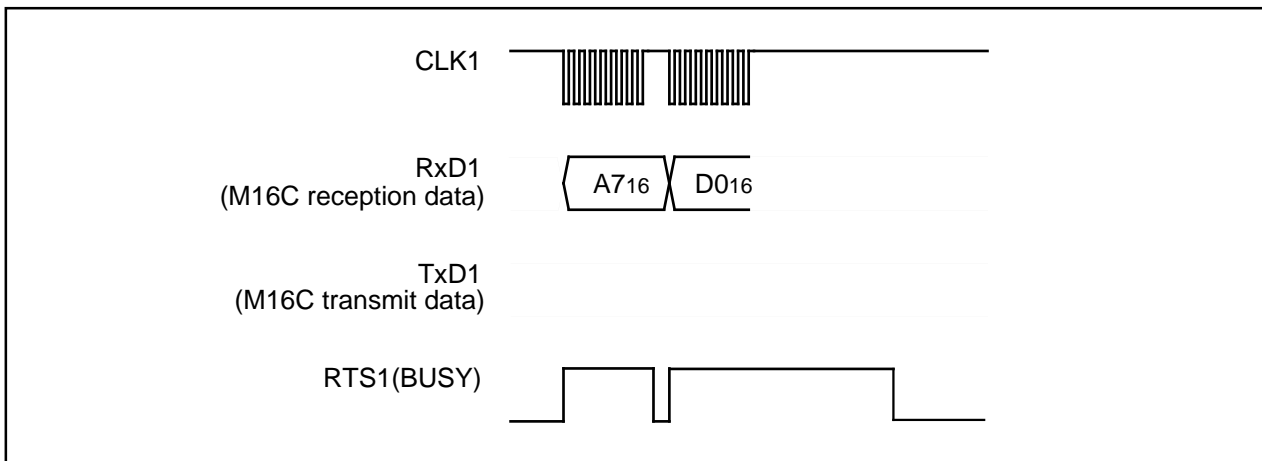

Figure 1.32.7. Timing for erasing all unlocked blocks

Lock Bit Program Command

This command writes "0" (lock) for the lock bit of the specified block. Execute the lock bit program command as explained here following.

- (1) Transfer the "77₁₆" command code with the 1st byte.
- (2) Transfer addresses A8 to A15 and A16 to A23 with the 2nd and 3rd bytes respectively.
- (3) Transfer the verify command code "D0₁₆" with the 4th byte. With the verify command code, "0" is written for the lock bit of the specified block. Write the highest address of the specified block for addresses A8 to A23.

When writing ends, the RTS₁ (BUSY) signal changes from the "H" to the "L" level. Lock bit status can be read with the read lock bit status command. For information on the lock bit function, reset procedure and so on, see the section on the data protection function.

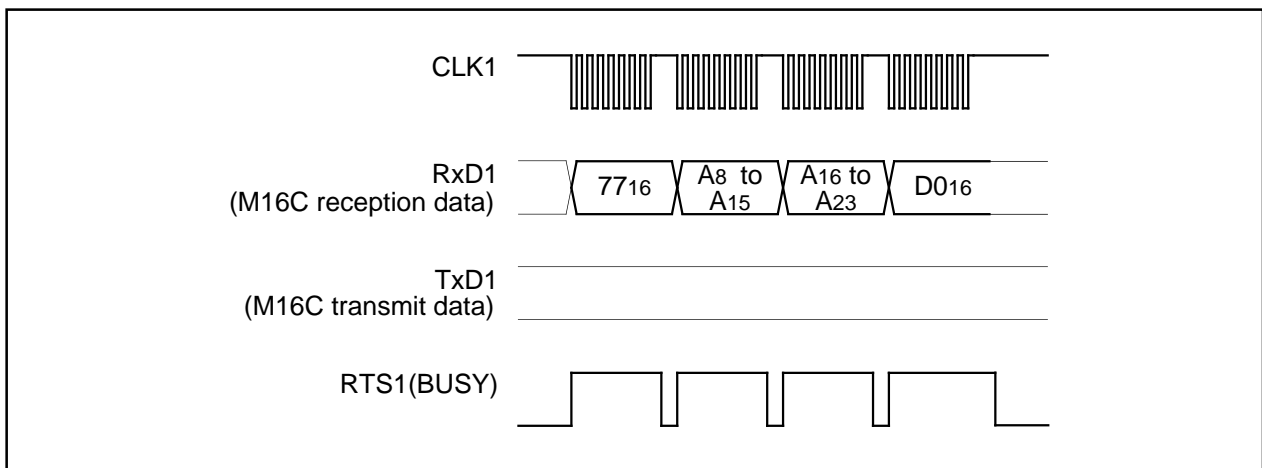

Figure 1.32.8 Timing for the lock bit program

Read Lock Bit Status Command

This command reads the lock bit status of the specified block. Execute the read lock bit status command as explained here following.

- (1) Transfer the "7116" command code with the 1st byte.
- (2) Transfer addresses A8 to A15 and A16 to A23 with the 2nd and 3rd bytes respectively.
- (3) The lock bit data of the specified block is output with the 4th byte. The lock bit data is the 6th bit(D6) of the output data. Write the highest address of the specified block for addresses A8 to A23.

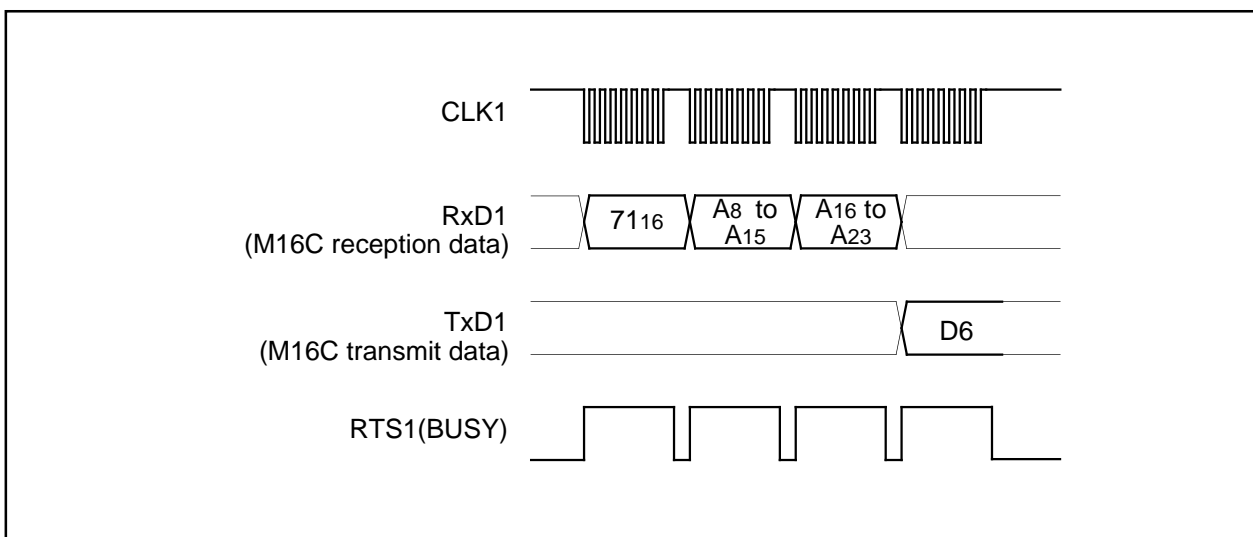

Figure 1.32.9. Timing for reading lock bit status

Lock Bit Enable Command

This command enables the lock bit in blocks whose bit was disabled with the lock bit disable command. The command code "7A16" is sent with the 1st byte of the serial transmission. This command only enables the lock bit function; it does not set the lock bit itself.

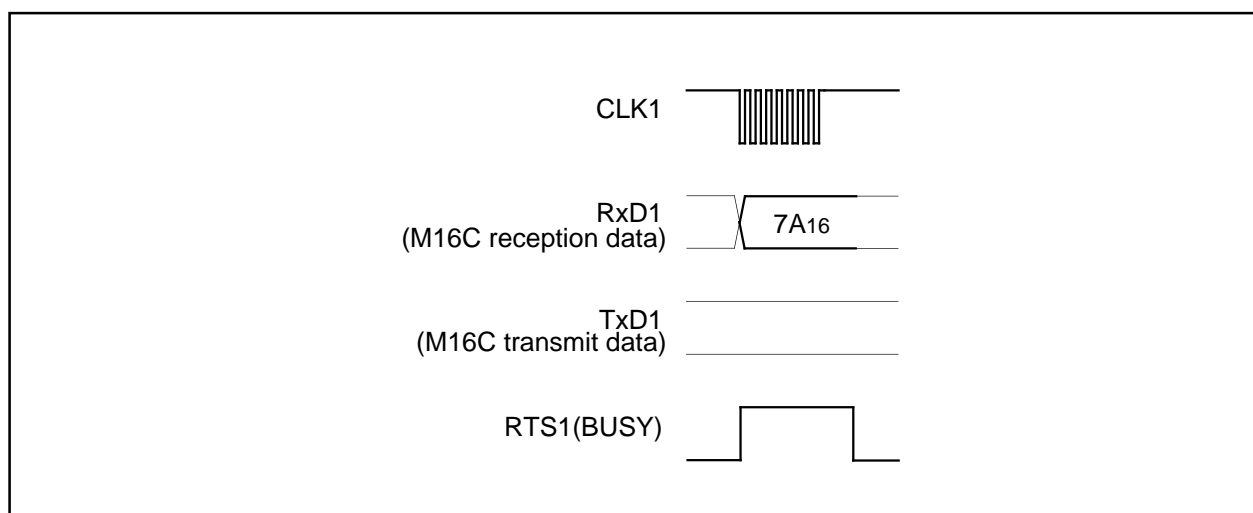

Figure 1.32.10. Timing for enabling the lock bit

Lock Bit Disable Command

This command disables the lock bit. The command code “7516” is sent with the 1st byte of the serial transmission. This command only disables the lock bit function; it does not set the lock bit itself. However, if an erase command is executed after executing the lock bit disable command, “0” (locked) lock bit data is set to “1” (unlocked) after the erase operation ends. In any case, after the reset is cancelled, the lock bit is enabled.

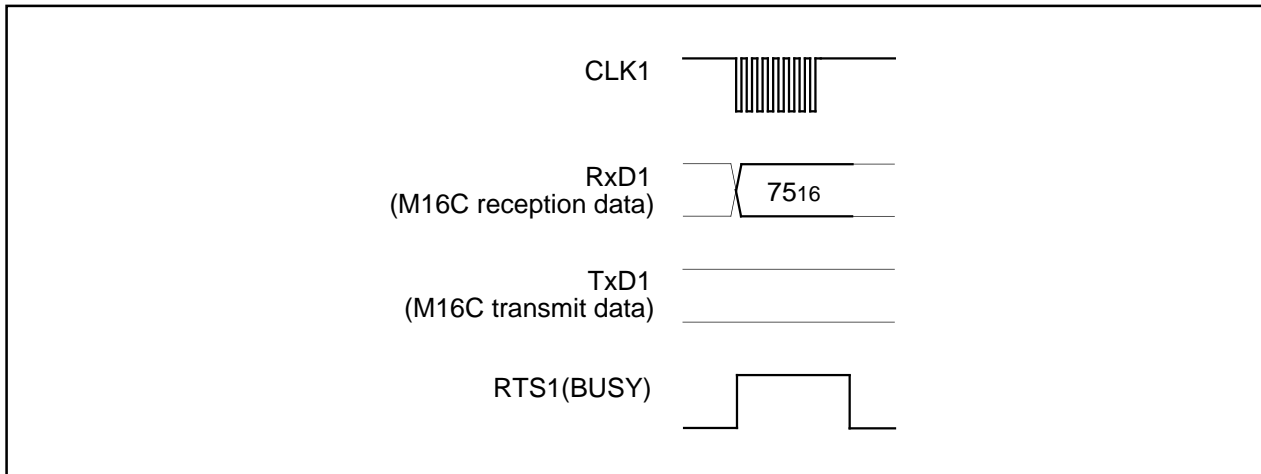

Figure 1.32.11. Timing for disabling the lock bit

Download Command

This command downloads a program to the RAM for execution. Execute the download command as explained here following.

- (1) Transfer the “FA16” command code with the 1st byte.
- (2) Transfer the program size with the 2nd and 3rd bytes.
- (3) Transfer the check sum with the 4th byte. The check sum is added to all data sent with the 5th byte onward.
- (4) The program to execute is sent with the 5th byte onward.

When all data has been transmitted, if the check sum matches, the downloaded program is executed. The size of the program will vary according to the internal RAM.

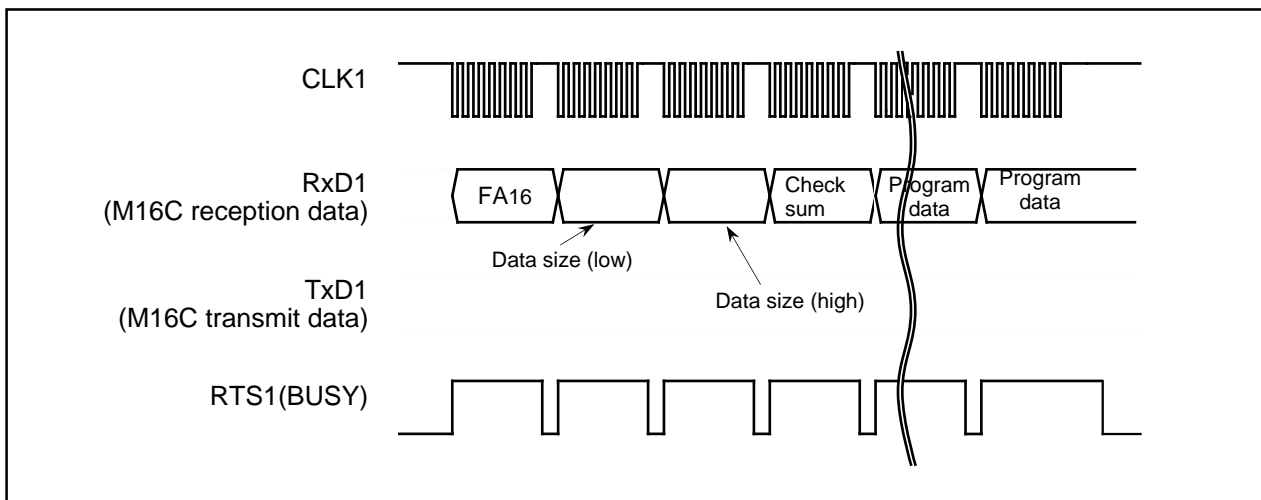

Figure 1.32.12. Timing for download

Version Information Output Command

This command outputs the version information of the control program stored in the boot area. Execute the version information output command as explained here following.

- (1) Transfer the "FB16" command code with the 1st byte.
- (2) The version information will be output from the 2nd byte onward. This data is composed of 8 ASCII code characters.

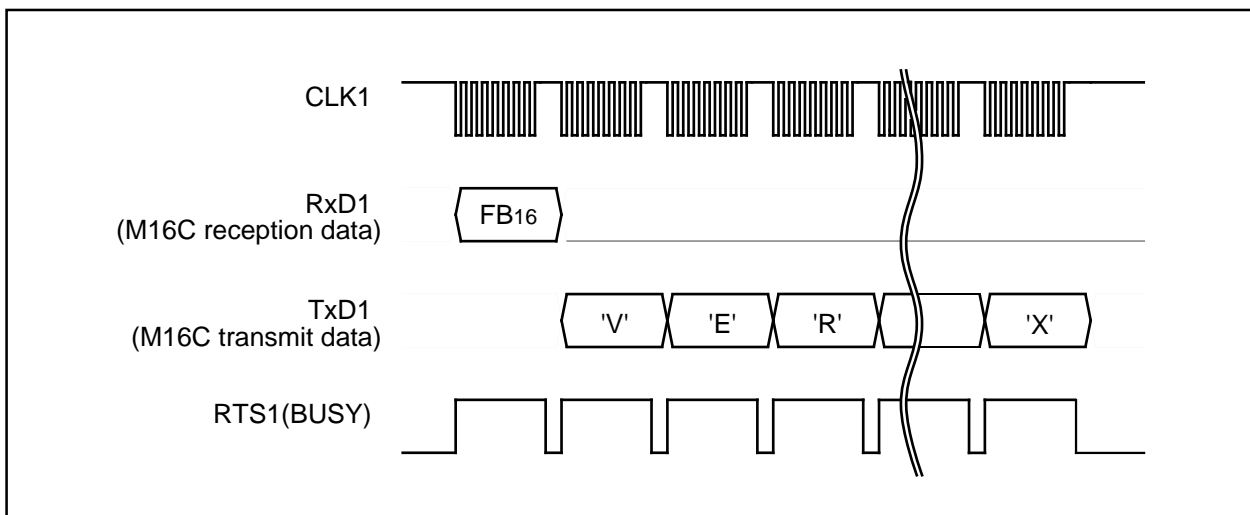

Figure 1.32.13. Timing for version information output

Boot ROM Area Output Command

This command outputs the control program stored in the boot ROM area in one page blocks (256 bytes). Execute the boot ROM area output command as explained here following.

- (1) Transfer the "FC16" command code with the 1st byte.
- (2) Transfer addresses A8 to A15 and A16 to A23 with the 2nd and 3rd bytes respectively.
- (3) From the 4th byte onward, data (D0–D7) for the page (256 bytes) specified with addresses A8 to A23 will be output sequentially from the smallest address first, in sync with the fall of the clock.

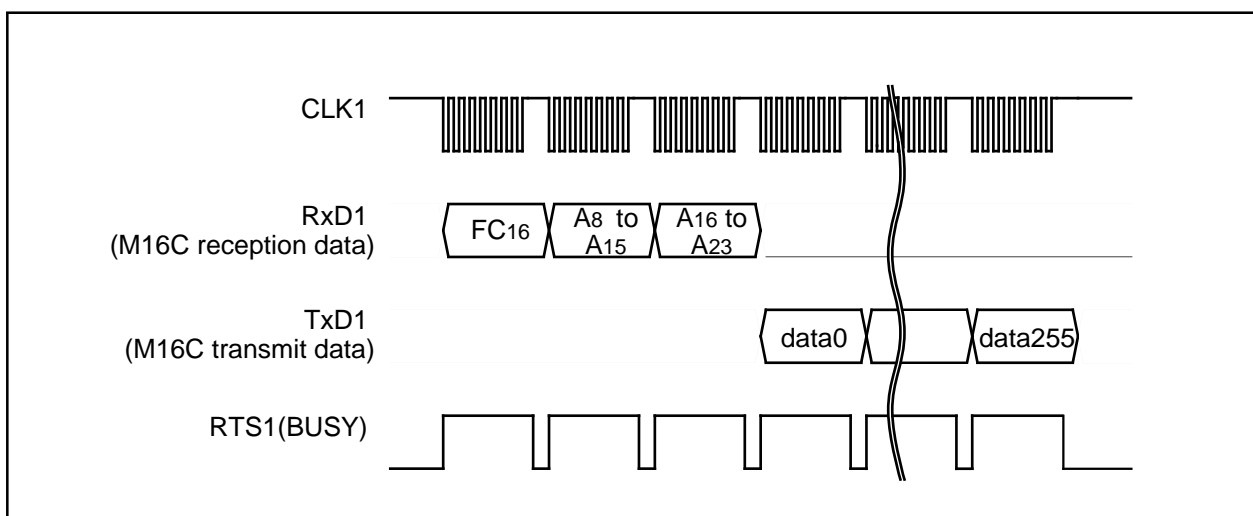

Figure 1.32.14. Timing for boot ROM area output

ID Check

This command checks the ID code. Execute the boot ID check command as explained here following.

- (1) Transfer the "F5₁₆" command code with the 1st byte.
- (2) Transfer addresses A₀ to A₇, A₈ to A₁₅ and A₁₆ to A₂₃ of the 1st byte of the ID code with the 2nd, 3rd and 4th bytes respectively.
- (3) Transfer the number of data sets of the ID code with the 5th byte.
- (4) The ID code is sent with the 6th byte onward, starting with the 1st byte of the code.

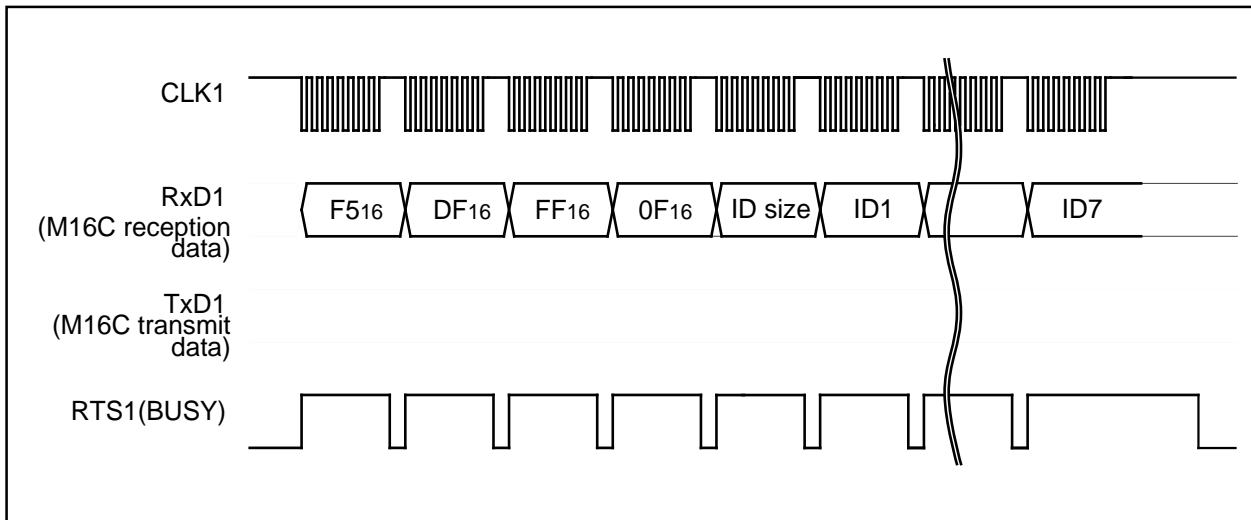

Figure 1.32.15. Timing for the ID check

ID Code

When the flash memory is not blank, the ID code sent from the peripheral units and the ID code written in the flash memory are compared to see if they match. If the codes do not match, the command sent from the peripheral units is not accepted. An ID code contains 8 bits of data. Area is, from the 1st byte, addresses 0FFFD₁₆, 0FFFE₃₁₆, 0FFFE_{B16}, 0FFFE_{F16}, 0FFFF₃₁₆, 0FFFF₇₁₆ and 0FFFF_{B16}. Write a program into the flash memory, which already has the ID code set for these addresses.

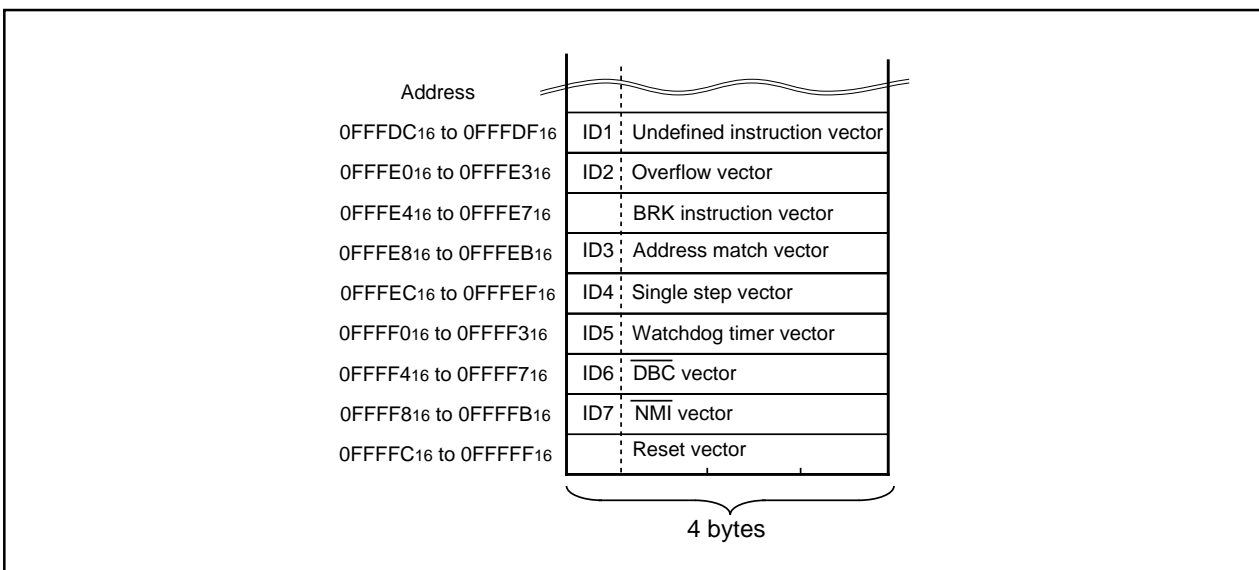

Figure 1.32.16. ID code storage addresses

Read Check Data

This command reads the check data that confirms that the write data, which was sent with the page program command, was successfully received.

- (1) Transfer the "FD16" command code with the 1st byte.
- (2) The check data (low) is received with the 2nd byte and the check data (high) with the 3rd.

To use this read check data command, first execute the command and then initialize the check data. Next, execute the page program command the required number of times. After that, when the read check command is executed again, the check data for all of the read data that was sent with the page program command during this time is read. The check data is the result of CRC operation of write data.

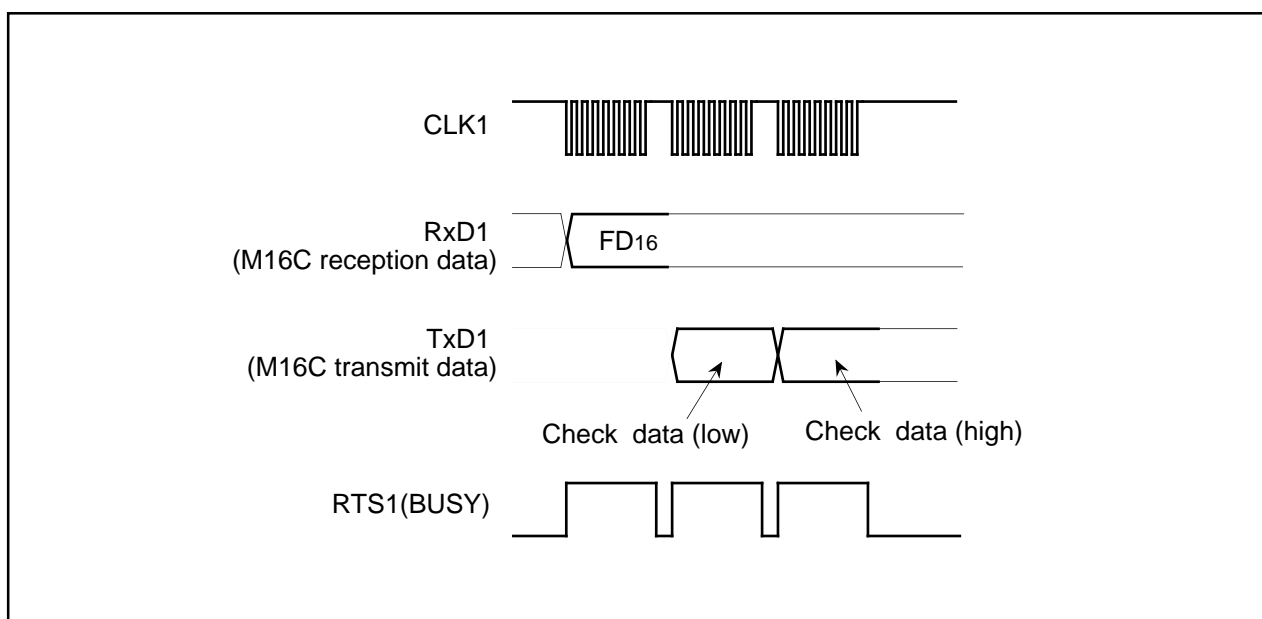

Figure 1.32.17. Timing for the read check data

Data Protection (Block Lock)

Each of the blocks in Figure 1.32.18 have a nonvolatile lock bit that specifies protection (block lock) against erasing/writing. A block is locked (writing “0” for the lock bit) with the lock bit program command. Also, the lock bit of any block can be read with the read lock bit status command.

Block lock disable/enable is determined by the status of the lock bit itself and execution status of the lock bit disable and lock enable bit commands.

- (1) After the reset has been cancelled and the lock bit enable command executed, the specified block can be locked/unlocked using the lock bit (lock bit data). Blocks with a “0” lock bit data are locked and cannot be erased or written in. On the other hand, blocks with a “1” lock bit data are unlocked and can be erased or written in.
- (2) After the lock bit disable command has been executed, all blocks are unlocked regardless of lock bit data status and can be erased or written in. In this case, lock bit data that was “0” before the block was erased is set to “1” (unlocked) after erasing, therefore the block is actually unlocked with the lock bit.

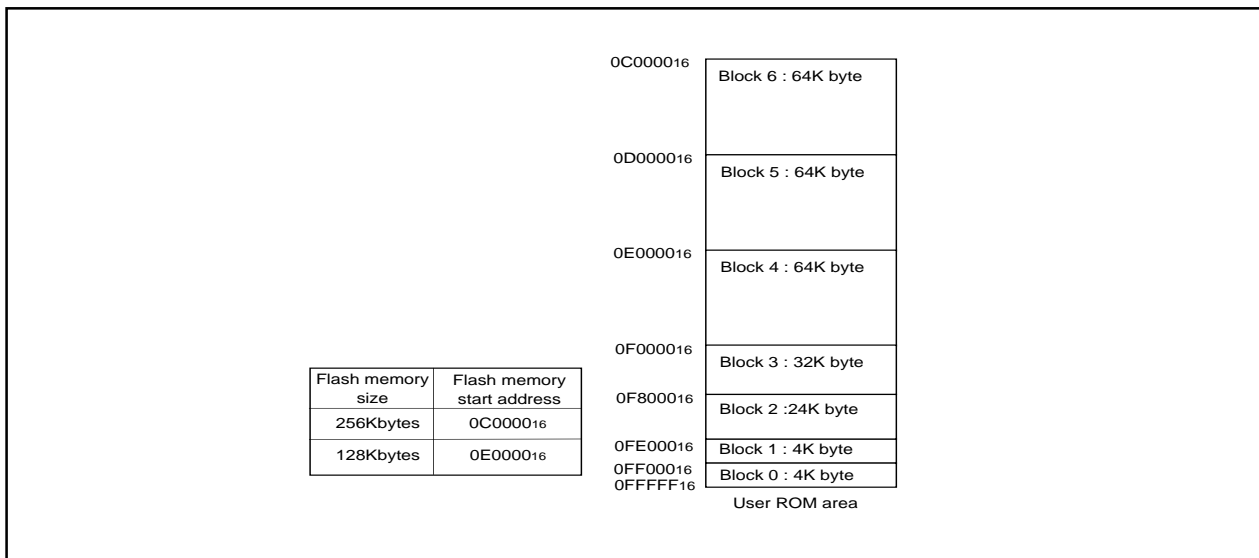

Figure 1.32.18. Blocks in the user area

Status Register (SRD)

The status register indicates operating status of the flash memory and status such as whether an erase operation or a program ended successfully or in error. It can be read by writing the read status register command (70₁₆). Also, the status register is cleared by writing the clear status register command (50₁₆). Table 1.32.2 gives the definition of each status register bit. After clearing the reset, the status register outputs "80₁₆".

Table 1.32.2. Status register (SRD)

SRD0 bits	Status name	Definition	
		"1"	"0"
SR7 (bit7)	Sequencer status	Ready	Busy
SR6 (bit6)	Reserved	-	-
SR5 (bit5)	Erase status	Terminated in error	Terminated normally
SR4 (bit4)	Program status	Terminated in error	Terminated normally
SR3 (bit3)	Reserved	-	-
SR2 (bit2)	Reserved	-	-
SR1 (bit1)	Reserved	-	-
SR0 (bit0)	Reserved	-	-

Sequencer status (SR7)

After power-on, the sequencer status is set to 1 (ready).

The sequencer status indicates the operating status of the device. This status bit is set to "0" (busy) during write or erase operation and is set to 1 upon completion of these operations.

Erase Status (SR5)

The erase status reports the operating status of the auto erase operation. If an erase error occurs, it is set to "1". When the erase status is cleared, it is set to "0".

Program Status (SR4)

The program status reports the operating status of the auto write operation. If a write error occurs, it is set to "1". When the program status is cleared, it is set to "0".

Status Register 1 (SRD1)

Status register 1 indicates the status of serial communications, results from ID checks and results from check sum comparisons. It can be read after the SRD by writing the read status register command (7016). Also, status register 1 is cleared by writing the clear status register command (5016).

Table 1.32.3 gives the definition of each status register 1 bit. "0016" is output when power is turned ON and the flag status is maintained even after the reset.

Table 1.32.3. Status register 1 (SRD1)

SRD1 bits	Status name	Definition	
		"1"	"0"
SR15 (bit7)	Boot update completed bit	Update completed	Not update
SR14 (bit6)	Flash identification value	HND	DINOR
SR13 (bit5)	Reserved	-	-
SR12 (bit4)	Check sum match bit	Match	Mismatch
SR11 (bit3) SR10 (bit2)	ID check completed bits	00 01 10 11	Not verified Verification mismatch Reserved Verified
SR9 (bit1)	Data receive time out	Time out	Normal operation
SR8 (bit0)	Reserved	-	-

Boot Update Completed Bit (SR15)

This flag indicates whether the control program was downloaded to the RAM or not, using the download function.

Flash Identification Value (SR14)

This flag indicates whether the flash memor type is HND or DINOR.

Check Sum Match Bit (SR12)

This flag indicates whether the check sum matches or not when a program, is downloaded for execution using the download function.

ID Check Completed Bits (SR11 and SR10)

These flags indicate the result of ID checks. Some commands cannot be accepted without an ID check.

Data Receive Time Out (SR9)

This flag indicates when a time out error is generated during data reception. If this flag is attached during data reception, the received data is discarded and the microcomputer returns to the command wait state.

Full Status Check

Results from executed erase and program operations can be known by running a full status check. Figure 1.32.19 shows a flowchart of the full status check and explains how to remedy errors which occur.

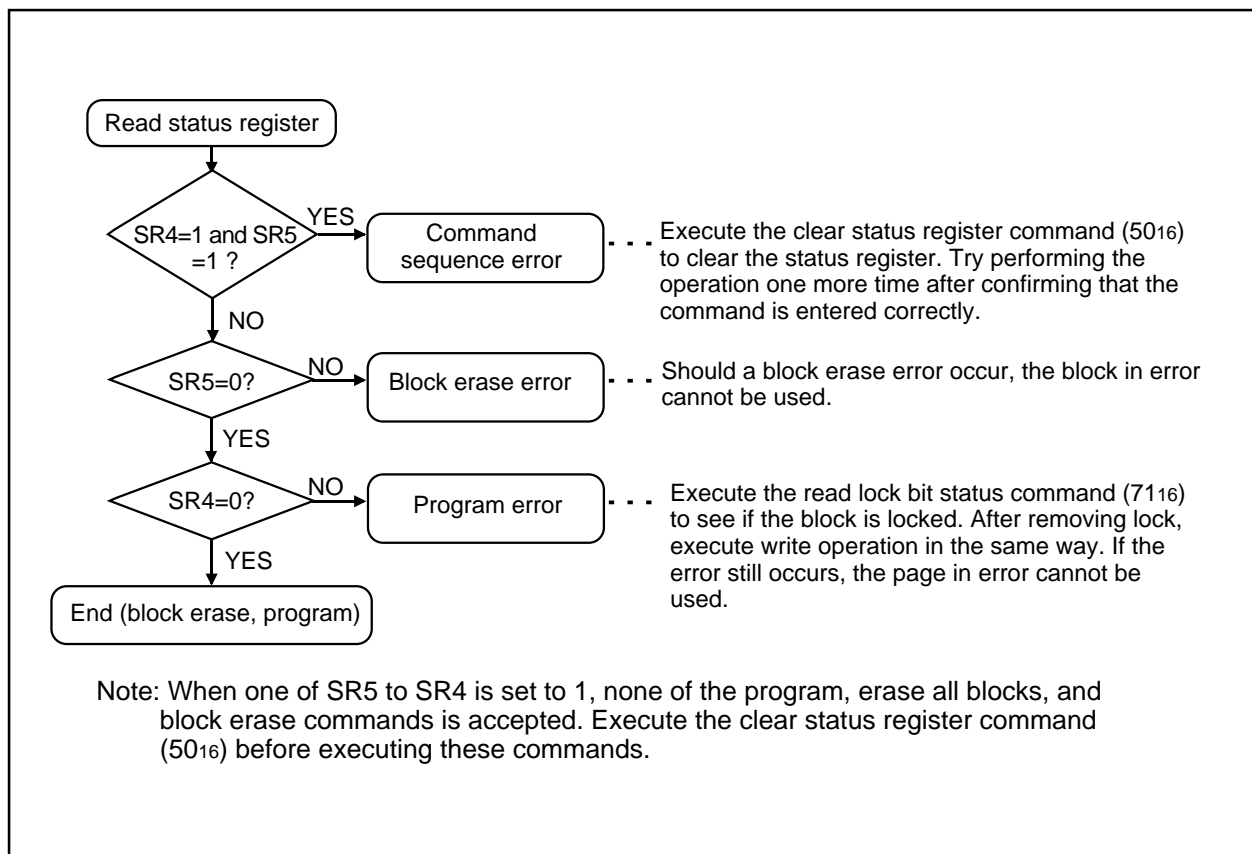

Figure 1.32.19. Full status check flowchart and remedial procedure for errors

Example Circuit Application for The Standard Serial I/O Mode 1

The below figure shows a circuit application for the standard serial I/O mode 1. Control pins will vary according to programmer, therefore see the peripheral unit manual for more information.

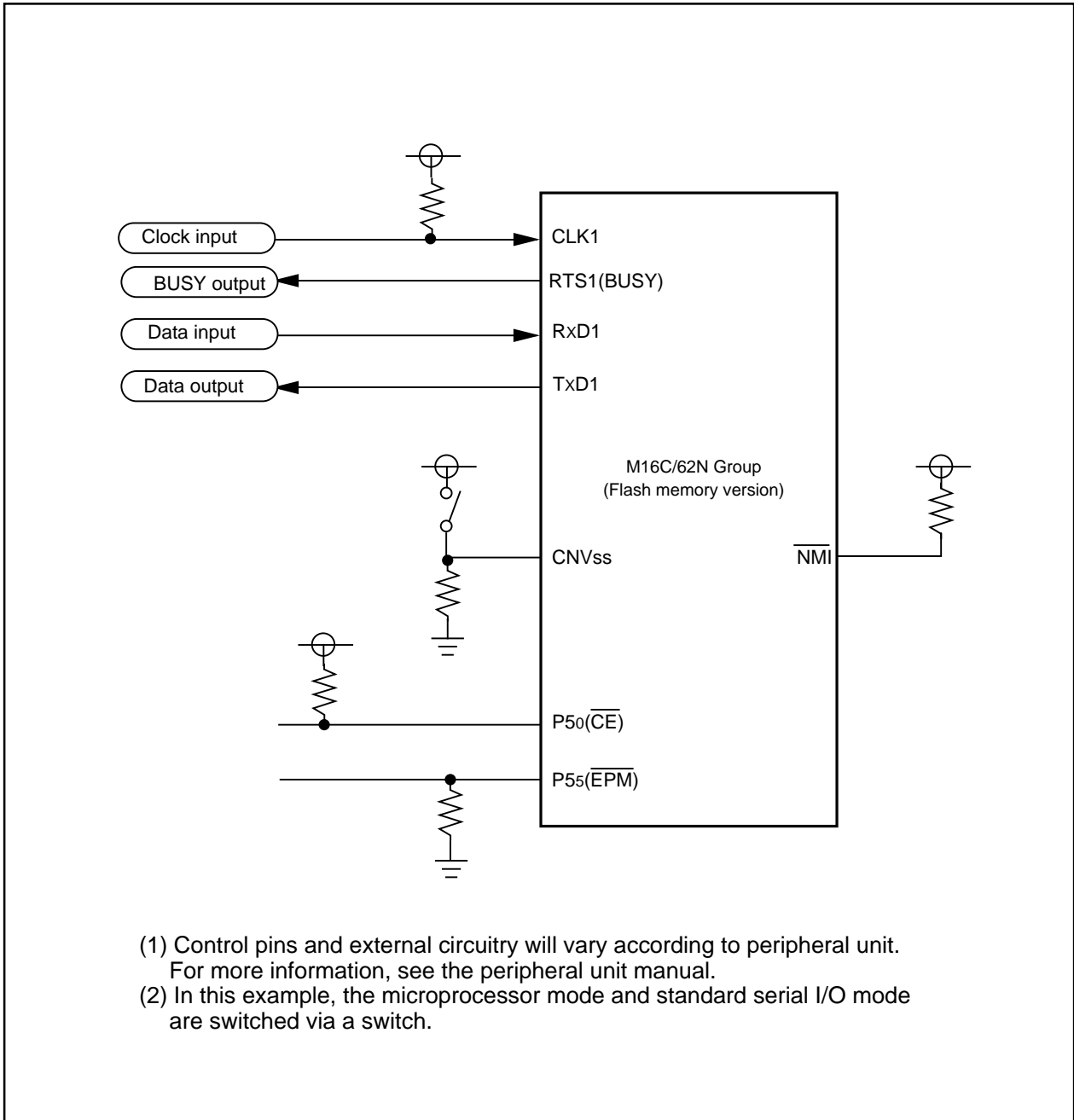

Figure 1.32.20. Example circuit application for the standard serial I/O mode 1

Overview of standard serial I/O mode 2 (clock asynchronous)

In standard serial I/O mode 2, software commands, addresses and data are input and output between the MCU and peripheral units (serial programmer, etc.) using 2-wire clock-asynchronized serial I/O (UART1). Standard serial I/O mode 2 is engaged by releasing the reset with the P65 (CLK1) pin "L" level.

The TxD1 pin is for CMOS output. Data transfer is in 8-bit units with LSB first, 1 stop bit and parity OFF.

After the reset is released, connections can be established at 9,600 bps when initial communications (Figure 1.32.21) are made with a peripheral unit. However, this requires a main clock with a minimum 2 MHz input oscillation frequency. Baud rate can also be changed from 9,600 bps to 19,200, 38,400 or 57,600 bps by executing software commands. However, communication errors may occur because of the oscillation frequency of the main clock. If errors occur, change the main clock's oscillation frequency and the baud rate.

After executing commands from a peripheral unit that requires time to erase and write data, as with erase and program commands, allow a sufficient time interval or execute the read status command and check how processing ended, before executing the next command.

Data and status registers in memory can be read after transmitting software commands. Status, such as the operating state of the flash memory or whether a program or erase operation ended successfully or not, can be checked by reading the status register. Here following are explained initial communications with peripheral units, how frequency is identified and software commands.

Initial communications with peripheral units

After the reset is released, the bit rate generator is adjusted to 9,600 bps to match the oscillation frequency of the main clock, by sending the code as prescribed by the protocol for initial communications with peripheral units (Figure 1.32.21).

- (1) Transmit "B016" from a peripheral unit. If the oscillation frequency input by the main clock is 10 or 16 MHz, the MCU with internal flash memory outputs the "B016" check code. If the oscillation frequency is anything other than 10 or 16 MHz, the MCU does not output anything.
- (2) Transmit "0016" from a peripheral unit 16 times. (The MCU with internal flash memory sets the bit rate generator so that "0016" can be successfully received.)
- (3) The MCU with internal flash memory outputs the "B016" check code and initial communications end successfully *1. Initial communications must be transmitted at a speed of 9,600 bps and a transfer interval of a minimum 15 ms. Also, the baud rate at the end of initial communications is 9,600 bps.

*1. If the peripheral unit cannot receive "B016" successfully, change the oscillation frequency of the main clock.

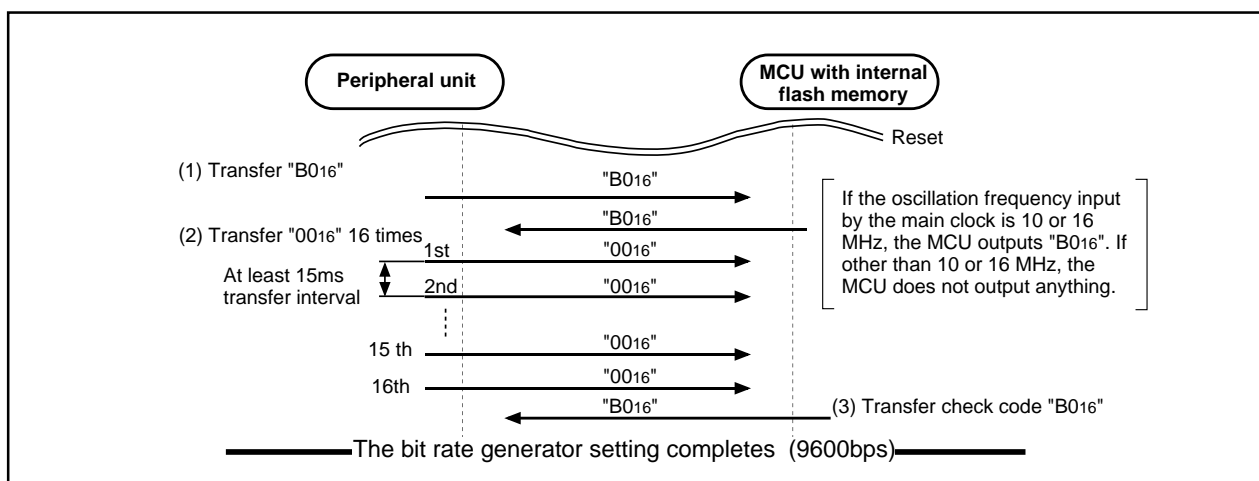

Figure 1.32.21. Peripheral unit and initial communication

How frequency is identified

When "0016" data is received 16 times from a peripheral unit at a baud rate of 9,600 bps, the value of the bit rate generator is set to match the operating frequency (2 - 16 MHz). The highest speed is taken from the first 8 transmissions and the lowest from the last 8. These values are then used to calculate the bit rate generator value for a baud rate of 9,600 bps.

Baud rate cannot be attained with some operating frequencies. Table 1.32.4 gives the operation frequency and the baud rate that can be attained for.

Table 1.32.4 Operation frequency and the baud rate

Operation frequency (MHz)	Baud rate 9,600bps	Baud rate 19,200bps	Baud rate 38,400bps	Baud rate 57,600bps
16MHz	√	√	√	√
12MHz	√	√	√	—
11MHz	√	√	√	—
10MHz	√	√	—	√
8MHz	√	√	—	√
7.3728MHz	√	√	√	√
6MHz	√	√	√	—
5MHz	√	√	—	—
4.5MHz	√	√	—	√
4.194304MHz	√	√	√	—
4MHz	√	√	—	—
3.58MHz	√	√	√	√
3MHz	√	√	√	—
2MHz	√	—	—	—

√ : Communications possible

— : Communications not possible

Software Commands

Table 1.32.5 lists software commands. In the standard serial I/O mode 2, erase operations, programs and reading are controlled by transferring software commands via the RxD1 pin. Standard serial I/O mode 2 adds four transmission speed commands - 9,600, 19,200, 38,400 and 57,600 bps - to the software commands of standard serial I/O mode 1. Software commands are explained here below.

Table 1.32.5. Software commands (Standard serial I/O mode 2)

	Control command	1st byte transfer	2nd byte	3rd byte	4th byte	5th byte	6th byte		When ID is not verified
1	Page read	FF ₁₆	Address (middle)	Address (high)	Data output	Data output	Data output	Data output to 259th byte	Not acceptable
2	Page program	41 ₁₆	Address (middle)	Address (high)	Data input	Data input	Data input	Data input to 259th byte	Not acceptable
3	Block erase	20 ₁₆	Address (middle)	Address (high)	D0 ₁₆				Not acceptable
4	Erase all unlocked blocks	A7 ₁₆	D0 ₁₆						Not acceptable
5	Read status register	70 ₁₆	SRD output	SRD1 output					Acceptable
6	Clear status register	50 ₁₆							Not acceptable
7	Read lock bit status	71 ₁₆	Address (middle)	Address (high)	Lock bit data output				Not acceptable
8	Lock bit program	77 ₁₆	Address (middle)	Address (high)	D0 ₁₆				Not acceptable
9	Lock bit enable	7A ₁₆							Not acceptable
10	Lock bit disable	75 ₁₆							Not acceptable
11	ID check function	F5 ₁₆	Address (low)	Address (middle)	Address (high)	ID size	ID1	To ID7	Acceptable
12	Download function	FA ₁₆	Size (low)	Size (high)	Check-sum	Data input	To required number of times		Not acceptable
13	Version data output function	FB ₁₆	Version data output	Version data output	Version data output	Version data output	Version data output	Version data output to 9th byte	Acceptable
14	Boot ROM area output function	FC ₁₆	Address (middle)	Address (high)	Data output	Data output	Data output	Data output to 259th byte	Not acceptable
15	Read check data	FD ₁₆	Check data (low)	Check data (high)					Not acceptable
16	Baud rate 9600	B0 ₁₆	B0 ₁₆						Acceptable
17	Baud rate 19200	B1 ₁₆	B1 ₁₆						Acceptable
18	Baud rate 38400	B2 ₁₆	B2 ₁₆						Acceptable
19	Baud rate 57600	B3 ₁₆	B3 ₁₆						Acceptable

Note 1: Shading indicates transfer from flash memory microcomputer to peripheral unit. All other data is transferred from the peripheral unit to the flash memory microcomputer.

Note 2: SRD refers to status register data. SRD1 refers to status register 1 data.

Note 3: All commands can be accepted when the flash memory is totally blank.

Page Read Command

This command reads the specified page (256 bytes) in the flash memory sequentially one byte at a time. Execute the page read command as explained here following.

- (1) Transfer the "FF16" command code with the 1st byte.
- (2) Transfer addresses A8 to A15 and A16 to A23 with the 2nd and 3rd bytes respectively.
- (3) From the 4th byte onward, data (D0–D7) for the page (256 bytes) specified with addresses A8 to A23 will be output sequentially from the smallest address first.

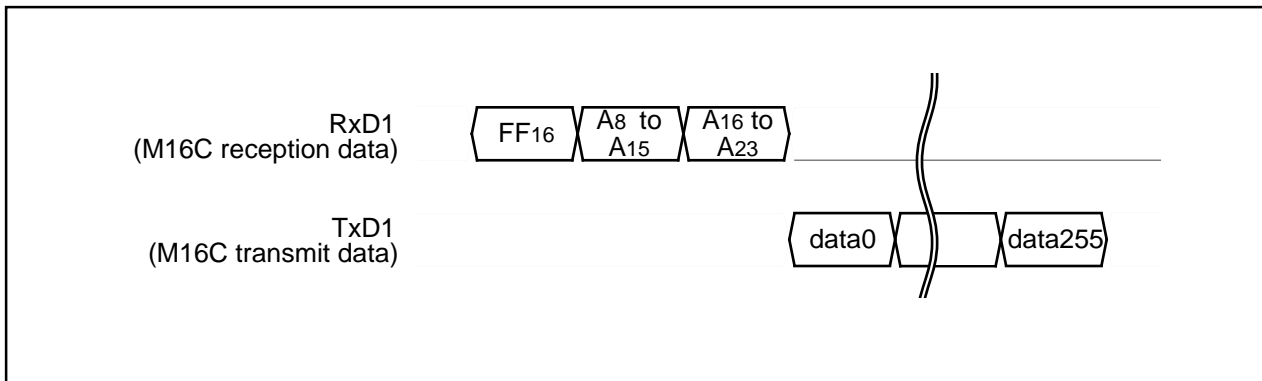

Figure 1.32.22. Timing for page read

Read Status Register Command

This command reads status information. When the "7016" command code is sent with the 1st byte, the contents of the status register (SRD) specified with the 2nd byte and the contents of status register 1 (SRD1) specified with the 3rd byte are read.

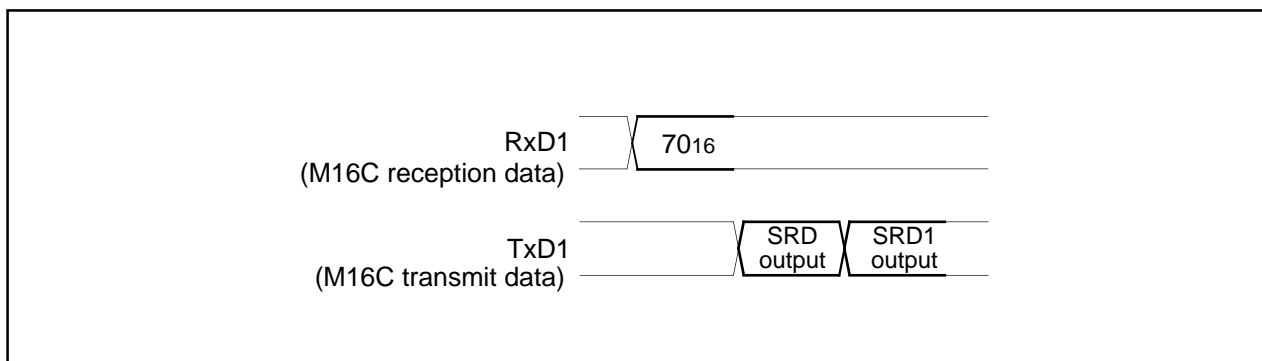

Figure 1.32.23. Timing for reading the status register

Clear Status Register Command

This command clears the bits (SR4, SR5) which are set when the status register operation ends in error. When the "50₁₆" command code is sent with the 1st byte, the aforementioned bits are cleared.

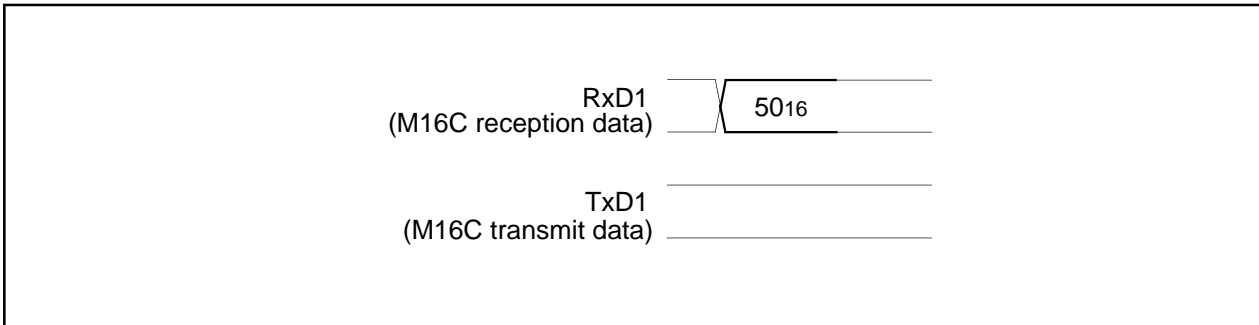

Figure 1.32.24. Timing for clearing the status register

Page Program Command

This command writes the specified page (256 bytes) in the flash memory sequentially one byte at a time. Execute the page program command as explained here following.

- (1) Transfer the "41₁₆" command code with the 1st byte.
- (2) Transfer addresses A8 to A15 and A16 to A23 with the 2nd and 3rd bytes respectively.
- (3) From the 4th byte onward, as write data (D₀–D₇) for the page (256 bytes) specified with addresses A8 to A23 is input sequentially from the smallest address first, that page is automatically written.

The result of the page program can be known by reading the status register. For more information, see the section on the status register.

Each block can be write-protected with the lock bit. For more information, see the section on the data protection function. Additional writing is not allowed with already programmed pages.

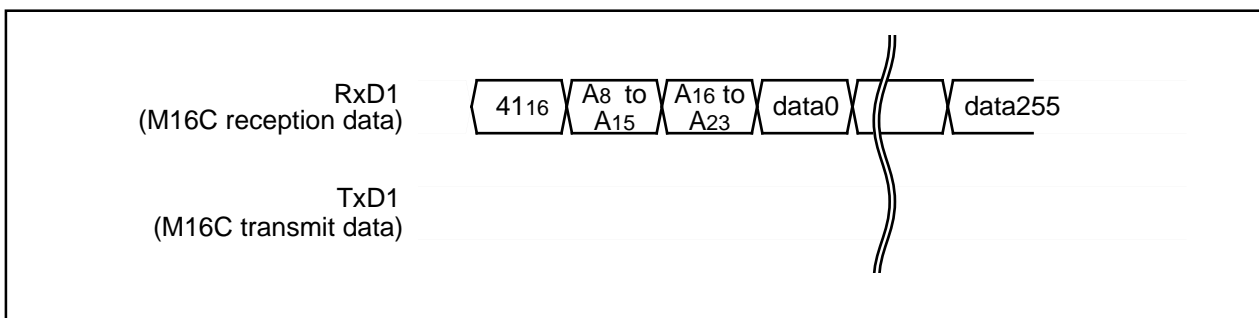

Figure 1.32.25. Timing for the page program

Block Erase Command

This command erases the data in the specified block. Execute the block erase command as explained here following.

- (1) Transfer the "2016" command code with the 1st byte.
- (2) Transfer addresses A8 to A15 and A16 to A23 with the 2nd and 3rd bytes respectively.
- (3) Transfer the verify command code "D016" with the 4th byte. With the verify command code, the erase operation will start for the specified block in the flash memory. Write the highest address of the specified block for addresses A8 to A23.

After block erase ends, the result of the block erase operation can be known by reading the status register. For more information, see the section on the status register.

Each block can be erase-protected with the lock bit. For more information, see the section on the data protection function.

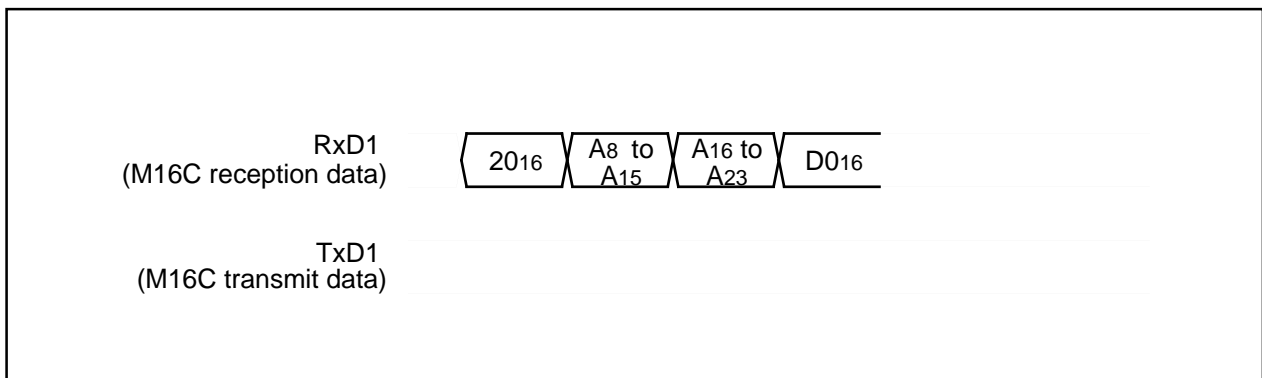

Figure 1.32.26. Timing for block erasing

Erase All Unlocked Blocks Command

This command erases the content of all blocks. Execute the erase all unlocked blocks command as explained here following.

- (1) Transfer the "A7₁₆" command code with the 1st byte.
- (2) Transfer the verify command code "D0₁₆" with the 2nd byte. With the verify command code, the erase operation will start and continue for all blocks in the flash memory.

The result of the erase operation can be known by reading the status register. Each block can be erase-protected with the lock bit. For more information, see the section on the data protection function.

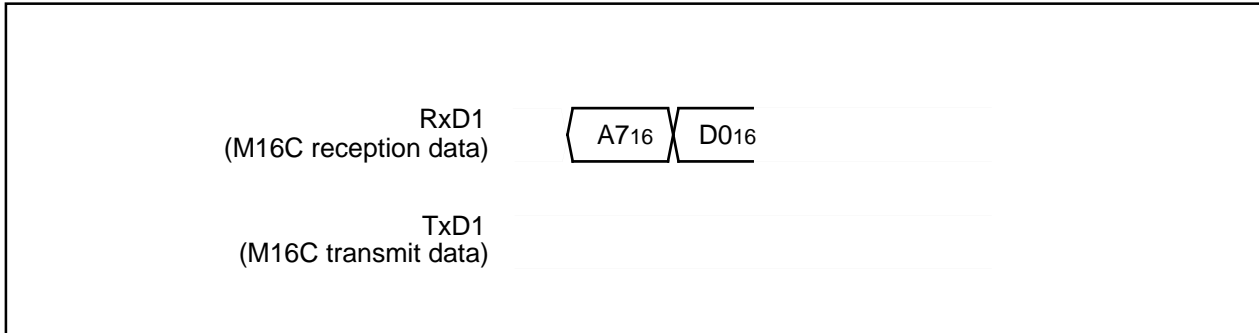

Figure 1.32.27. Timing for erasing all unlocked blocks

Lock Bit Program Command

This command writes "0" (lock) for the lock bit of the specified block. Execute the lock bit program command as explained here following.

- (1) Transfer the "77₁₆" command code with the 1st byte.
- (2) Transfer addresses A8 to A15 and A16 to A23 with the 2nd and 3rd bytes respectively.
- (3) Transfer the verify command code "D0₁₆" with the 4th byte. With the verify command code, "0" is written for the lock bit of the specified block. Write the highest address of the specified block for addresses A8 to A23.

Lock bit status can be read with the read lock bit status command. For information on the lock bit function, reset procedure and so on, see the section on the data protection function.

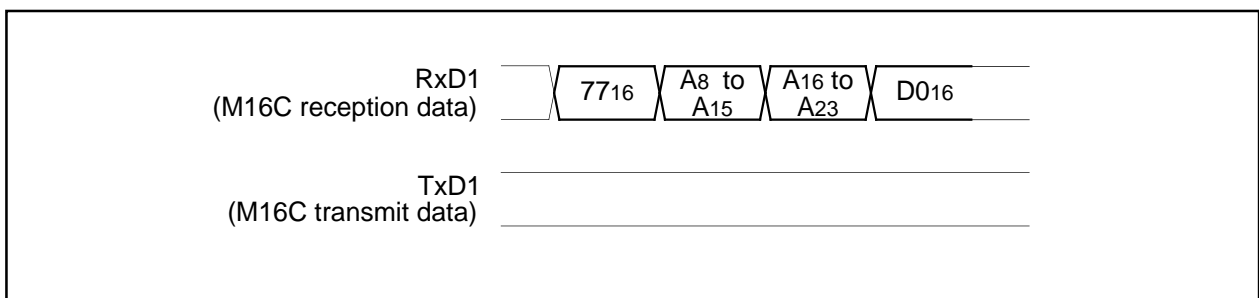

Figure 1.32.28. Timing for the lock bit program

Read Lock Bit Status Command

This command reads the lock bit status of the specified block. Execute the read lock bit status command as explained here following.

- (1) Transfer the "7116" command code with the 1st byte.
- (2) Transfer addresses A8 to A15 and A16 to A23 with the 2nd and 3rd bytes respectively.
- (3) The lock bit data of the specified block is output with the 4th byte. The lock bit data is the 6th bit(D6) of the output data. Write the highest address of the specified block for addresses A8 to A23.

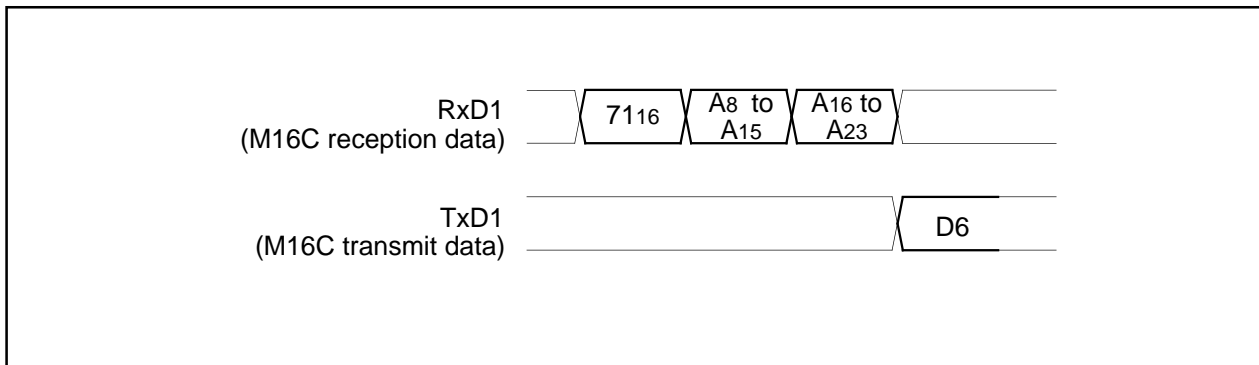

Figure 1.32.29. Timing for reading lock bit status

Lock Bit Enable Command

This command enables the lock bit in blocks whose bit was disabled with the lock bit disable command. The command code "7A16" is sent with the 1st byte of the serial transmission. This command only enables the lock bit function; it does not set the lock bit itself.

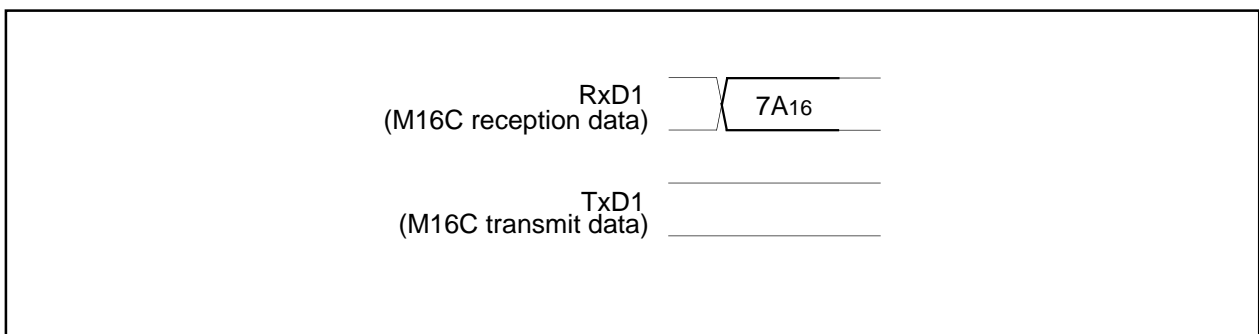

Figure 1.32.30. Timing for enabling the lock bit

Lock Bit Disable Command

This command disables the lock bit. The command code "7516" is sent with the 1st byte of the serial transmission. This command only disables the lock bit function; it does not set the lock bit itself. However, if an erase command is executed after executing the lock bit disable command, "0" (locked) lock bit data is set to "1" (unlocked) after the erase operation ends. In any case, after the reset is cancelled, the lock bit is enabled.

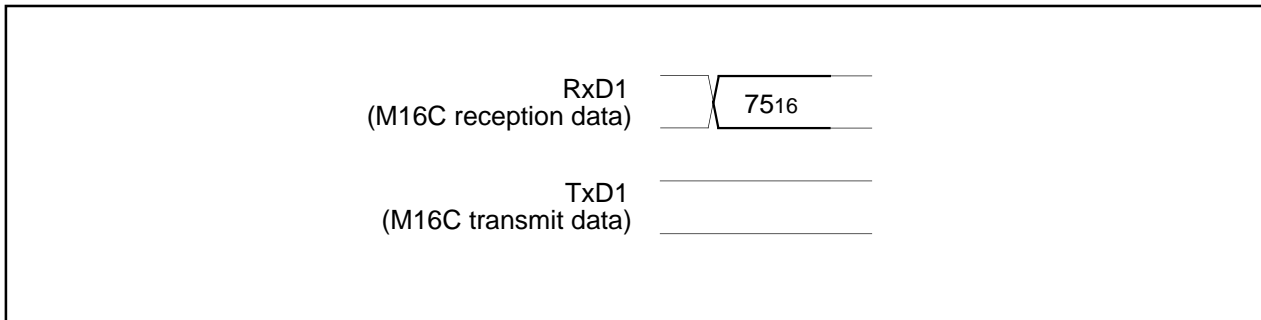

Figure 1.32.31. Timing for disabling the lock bit

Download Command

This command downloads a program to the RAM for execution. Execute the download command as explained here following.

- (1) Transfer the "FA16" command code with the 1st byte.
- (2) Transfer the program size with the 2nd and 3rd bytes.
- (3) Transfer the check sum with the 4th byte. The check sum is added to all data sent with the 5th byte onward.
- (4) The program to execute is sent with the 5th byte onward.

When all data has been transmitted, if the check sum matches, the downloaded program is executed. The size of the program will vary according to the internal RAM.

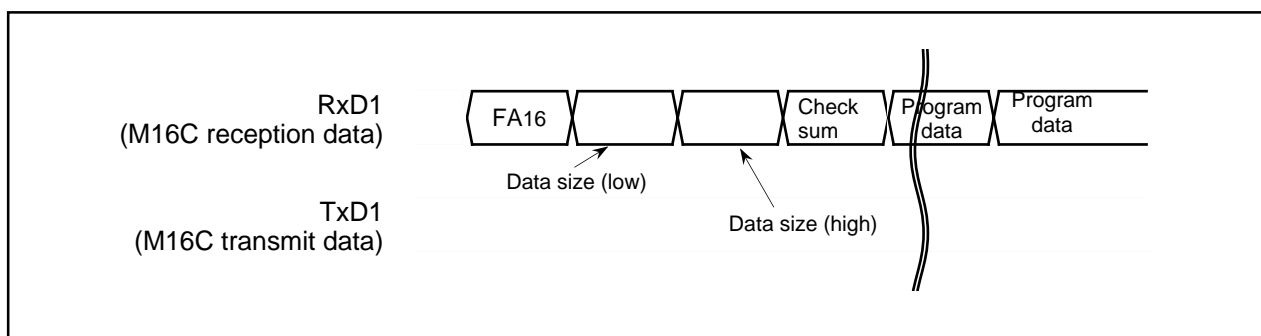

Figure 1.32.32. Timing for download

Version Information Output Command

This command outputs the version information of the control program stored in the boot area. Execute the version information output command as explained here following.

- (1) Transfer the "FB16" command code with the 1st byte.
- (2) The version information will be output from the 2nd byte onward. This data is composed of 8 ASCII code characters.

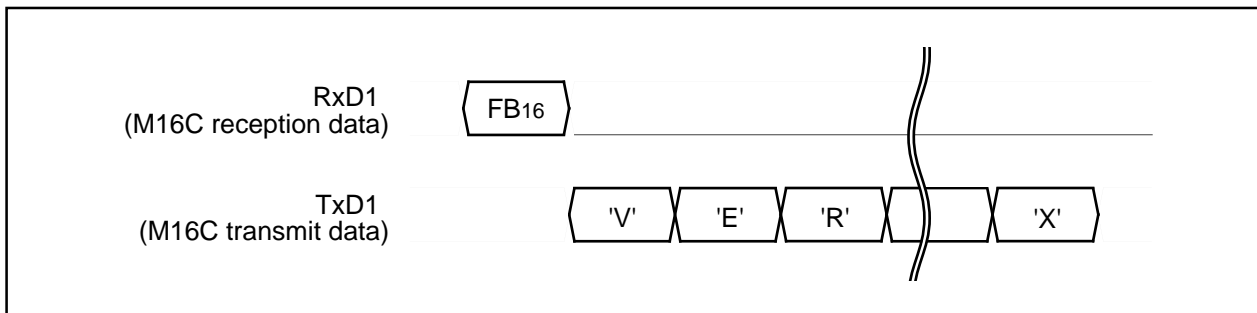

Figure 1.32.33. Timing for version information output

Boot ROM Area Output Command

This command outputs the control program stored in the boot ROM area in one page blocks (256 bytes). Execute the boot ROM area output command as explained here following.

- (1) Transfer the "FC16" command code with the 1st byte.
- (2) Transfer addresses A8 to A15 and A16 to A23 with the 2nd and 3rd bytes respectively.
- (3) From the 4th byte onward, data (D0–D7) for the page (256 bytes) specified with addresses A8 to A23 will be output sequentially from the smallest address first.

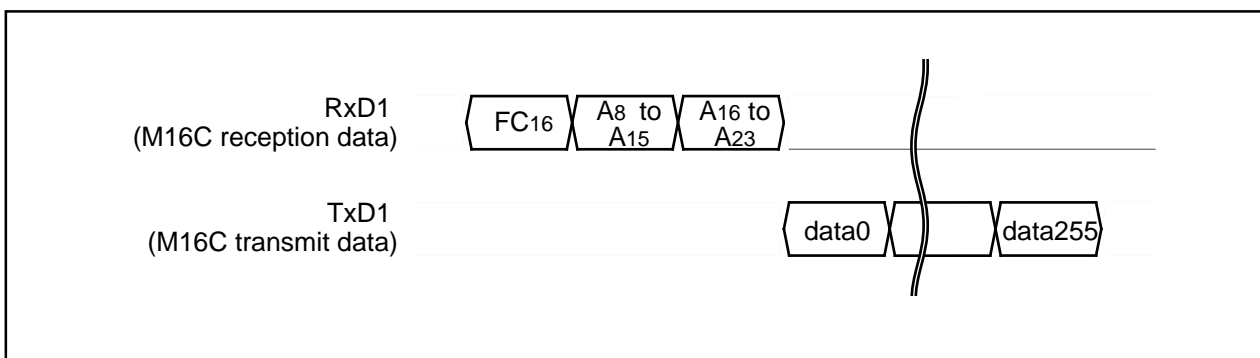

Figure 1.32.34. Timing for boot ROM area output

ID Check

This command checks the ID code. Execute the boot ID check command as explained here following.

- (1) Transfer the "F5₁₆" command code with the 1st byte.
- (2) Transfer addresses A₀ to A₇, A₈ to A₁₅ and A₁₆ to A₂₃ of the 1st byte of the ID code with the 2nd, 3rd and 4th bytes respectively.
- (3) Transfer the number of data sets of the ID code with the 5th byte.
- (4) The ID code is sent with the 6th byte onward, starting with the 1st byte of the code.

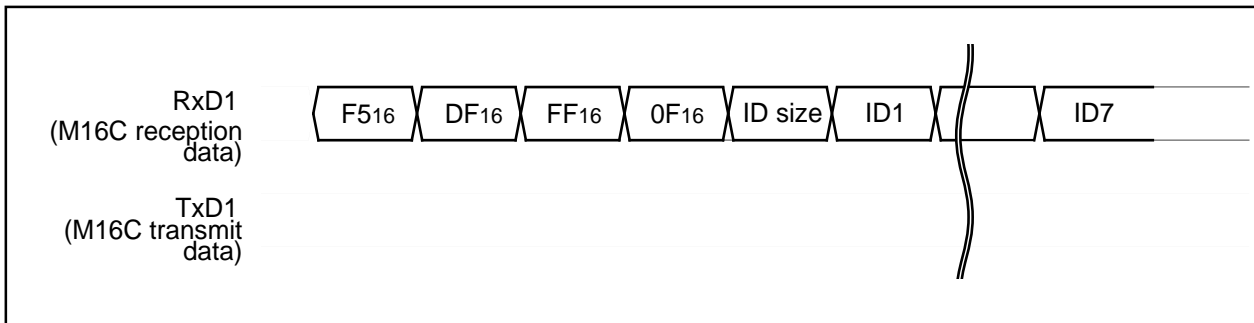

Figure 1.32.35. Timing for the ID check

ID Code

When the flash memory is not blank, the ID code sent from the peripheral units and the ID code written in the flash memory are compared to see if they match. If the codes do not match, the command sent from the peripheral units is not accepted. An ID code contains 8 bits of data. Area is, from the 1st byte, addresses 0FFFD₁₆, 0FFFE₃₁₆, 0FFFE_{B16}, 0FFFE_{F16}, 0FFFF₃₁₆, 0FFFF₇₁₆ and 0FFFF_{B16}. Write a program into the flash memory, which already has the ID code set for these addresses.

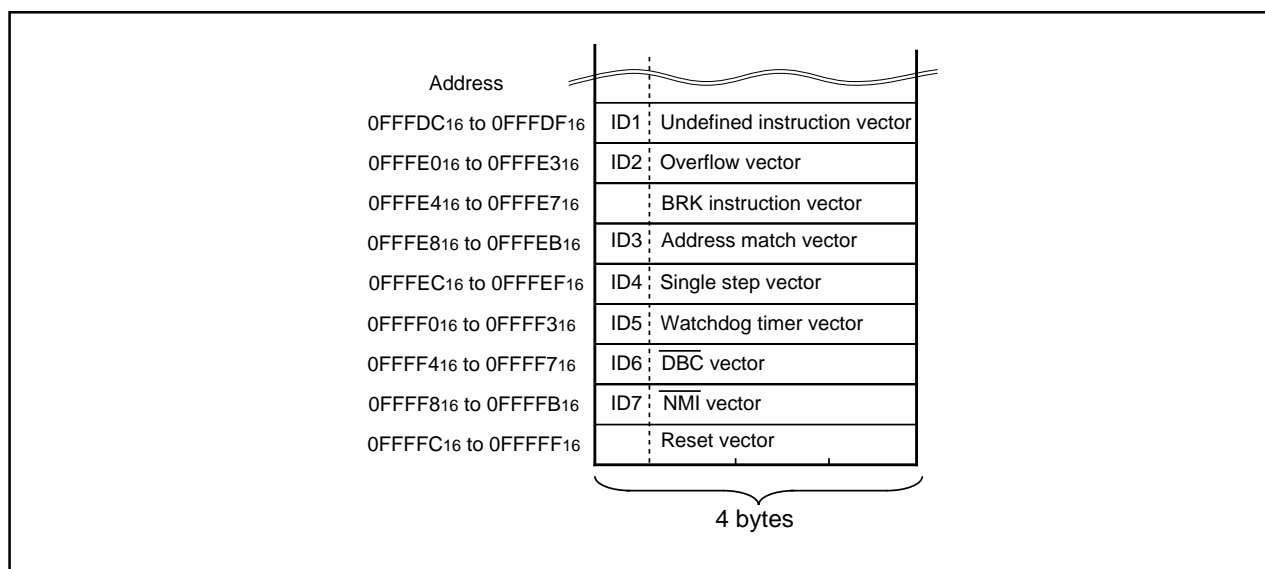

Figure 1.32.36. ID code storage addresses

Read Check Data

This command reads the check data that confirms that the write data, which was sent with the page program command, was successfully received.

- (1) Transfer the "FD16" command code with the 1st byte.
- (2) The check data (low) is received with the 2nd byte and the check data (high) with the 3rd.

To use this read check data command, first execute the command and then initialize the check data. Next, execute the page program command the required number of times. After that, when the read check command is executed again, the check data for all of the read data that was sent with the page program command during this time is read. The check data is the result of CRC operation of write data.

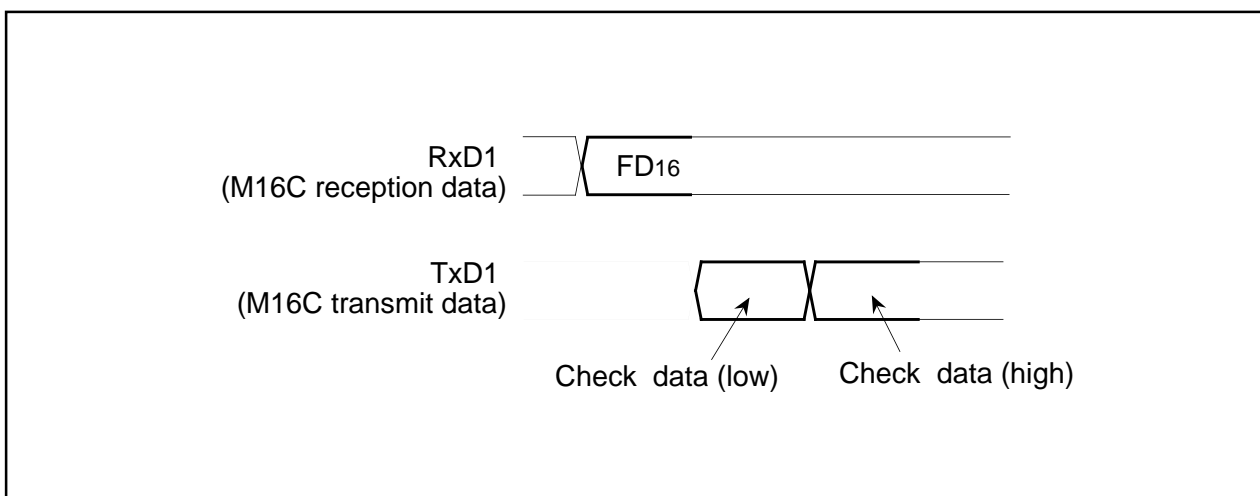

Figure 1.32.37. Timing for the read check data

Baud Rate 9600

This command changes baud rate to 9,600 bps. Execute it as follows.

- (1) Transfer the "B016" command code with the 1st byte.
- (2) After the "B016" check code is output with the 2nd byte, change the baud rate to 9,600 bps.

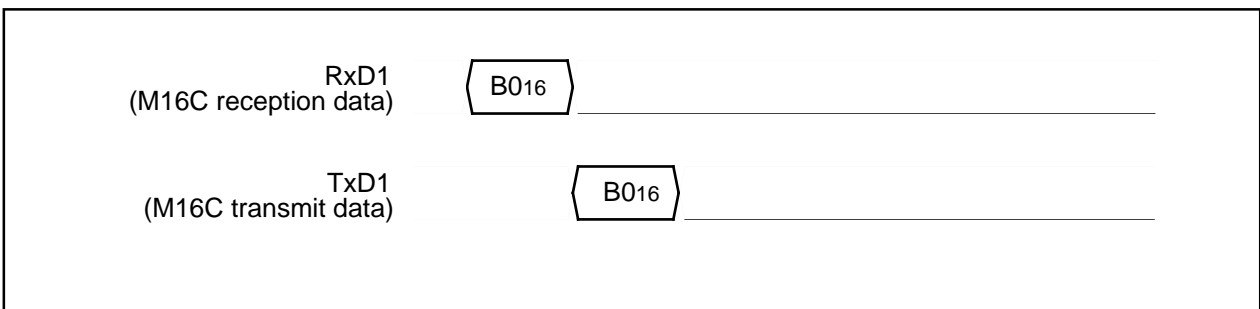

Figure 1.32.38. Timing of baud rate 9600

Baud Rate 19200

This command changes baud rate to 19,200 bps. Execute it as follows.

- (1) Transfer the "B116" command code with the 1st byte.
- (2) After the "B116" check code is output with the 2nd byte, change the baud rate to 19,200 bps.

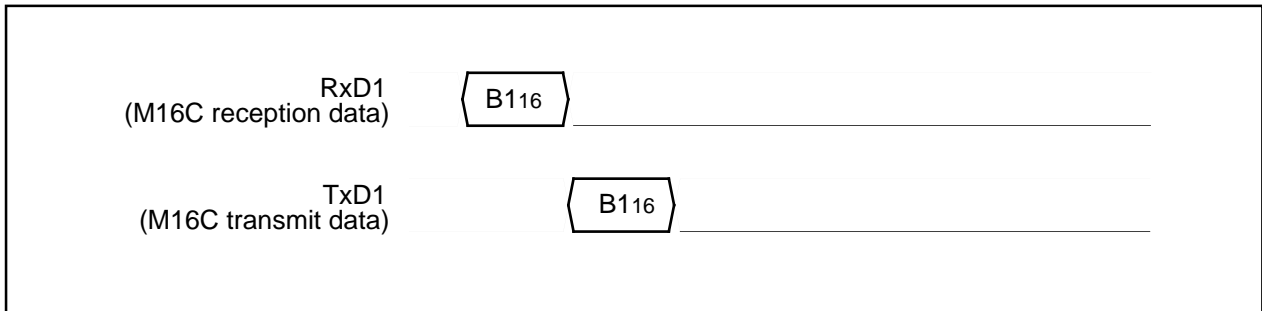

Figure 1.32.39. Timing of baud rate 19200

Baud Rate 38400

This command changes baud rate to 38,400 bps. Execute it as follows.

- (1) Transfer the "B216" command code with the 1st byte.
- (2) After the "B216" check code is output with the 2nd byte, change the baud rate to 38,400 bps.

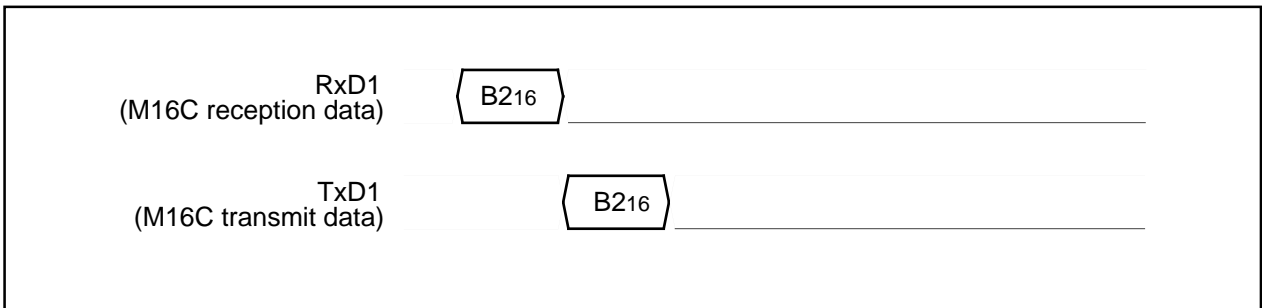

Figure 1.32.40. Timing of baud rate 38400

Baud Rate 57600

This command changes baud rate to 57,600 bps. Execute it as follows.

- (1) Transfer the "B316" command code with the 1st byte.
- (2) After the "B316" check code is output with the 2nd byte, change the baud rate to 57,600 bps.

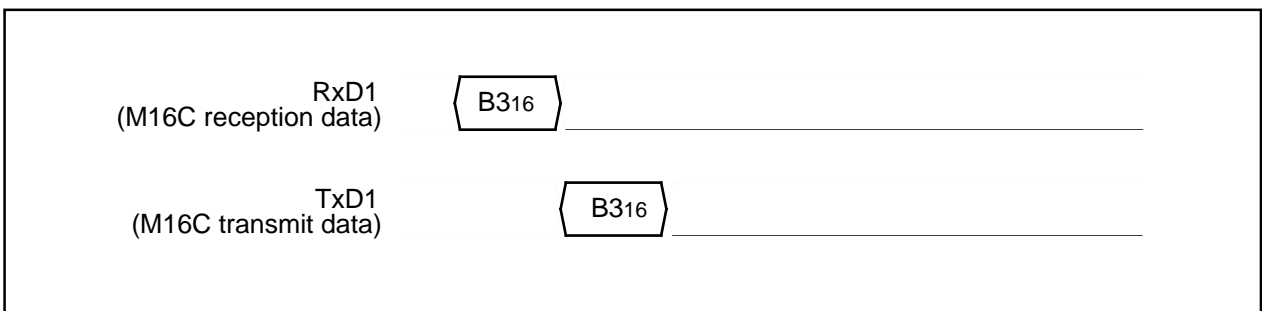

Figure 1.32.41. Timing of baud rate 57600

Example Circuit Application for The Standard Serial I/O Mode 2

The below figure shows a circuit application for the standard serial I/O mode 2.

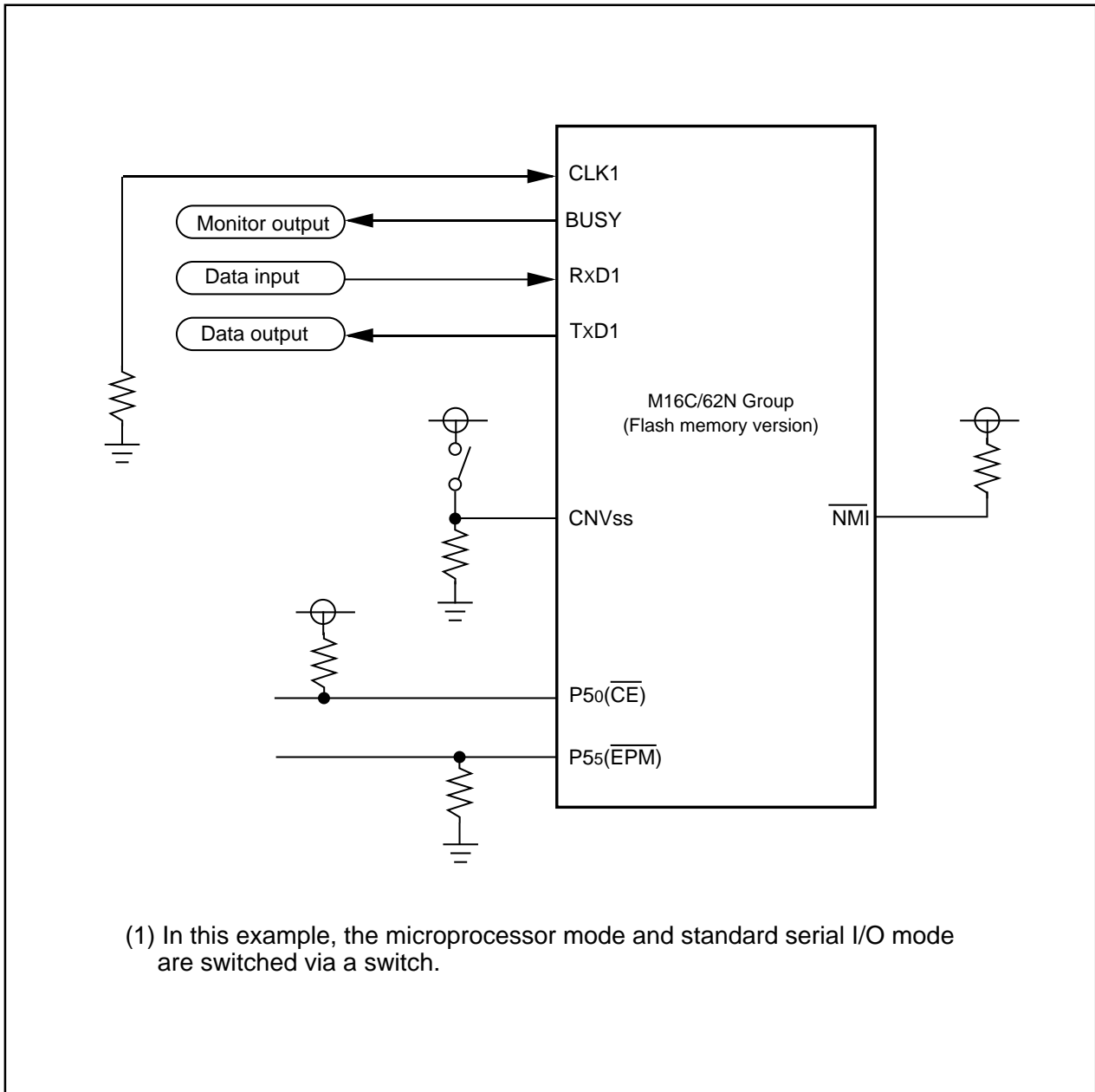

Figure 1.32.42. Example circuit application for the standard serial I/O mode 2

Package Outline

100P6S-A (MMP)

Plastic 100pin 14X20mm body QFP

EIAJ Package Code	JEDEC Code	Weight(g)	Lead Material
QFP100-P-1420-0.65	-	1.58	Alloy 42

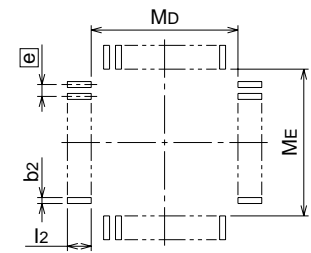
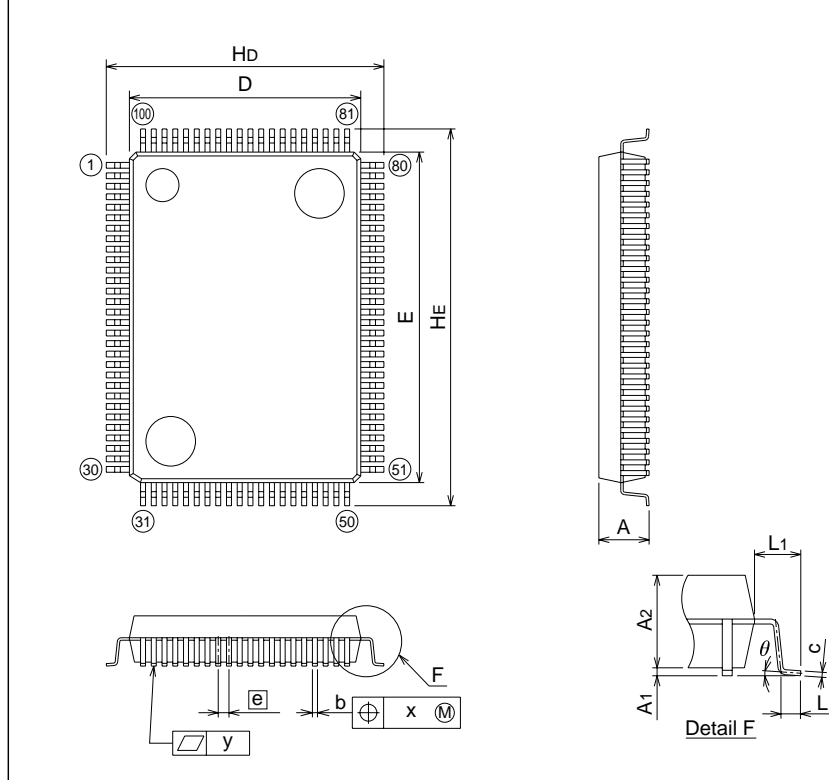

Recommended Mount Pad

Symbol	Dimension in Millimeters		
	Min	Nom	Max
A	-	-	3.05
A1	0	0.1	0.2
A2	-	2.8	-
b	0.25	0.3	0.4
c	0.13	0.15	0.2
D	13.8	14.0	14.2
E	19.8	20.0	20.2
e	-	0.65	-
Hd	16.5	16.8	17.1
HE	22.5	22.8	23.1
L	0.4	0.6	0.8
L1	-	1.4	-
x	-	-	0.13
y	-	-	0.1
θ	0°	-	10°
b2	-	0.35	-
l2	1.3	-	-
Md	-	14.6	-
ME	-	20.6	-

100P6Q-A (MMP)

Plastic 100pin 14X14mm body LQFP

EIAJ Package Code	JEDEC Code	Weight(g)	Lead Material
LQFP100-P-1414-0.50	-	0.63	Cu Alloy

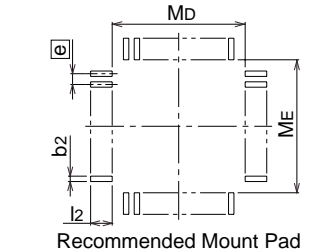
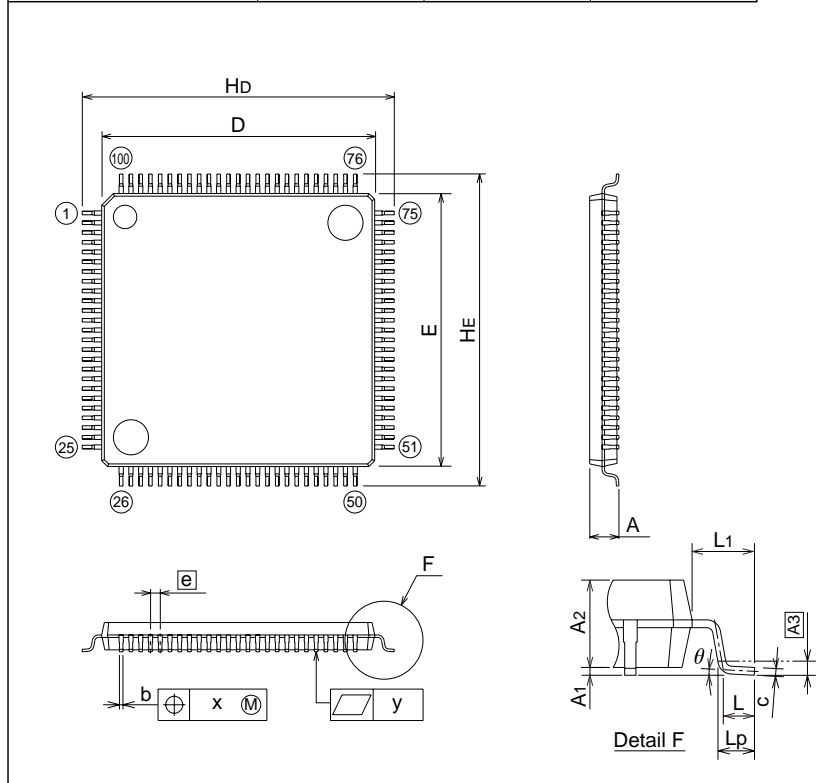

Recommended Mount Pad

Symbol	Dimension in Millimeters		
	Min	Nom	Max
A	-	-	1.7
A1	0	0.1	0.2
A2	-	1.4	-
b	0.13	0.18	0.28
c	0.105	0.125	0.175
D	13.9	14.0	14.1
E	13.9	14.0	14.1
e	-	0.5	-
Hd	15.8	16.0	16.2
HE	15.8	16.0	16.2
L	0.3	0.5	0.7
L1	-	1.0	-
Lp	0.45	0.6	0.75
A3	-	0.25	-
x	-	-	0.08
y	-	-	0.1
θ	0°	-	10°
b2	-	0.225	-
l2	0.9	-	-
Md	-	14.4	-
ME	-	14.4	-

100PFB-A

(MMP)

Plastic 100pin 12X12mm body TQFP

EIAJ Package Code	JEDEC Code	Weight(g)	Lead Material
TQFP100-P-1212-0.40	-	0.37	Cu Alloy

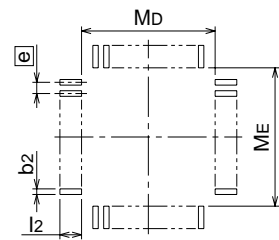
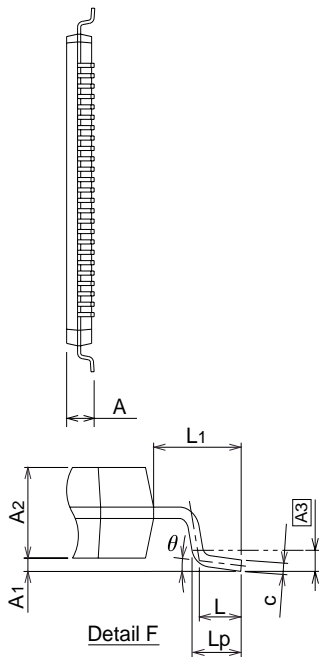
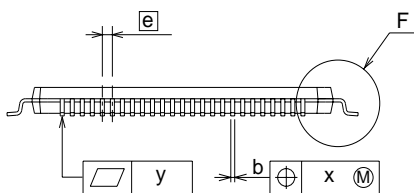
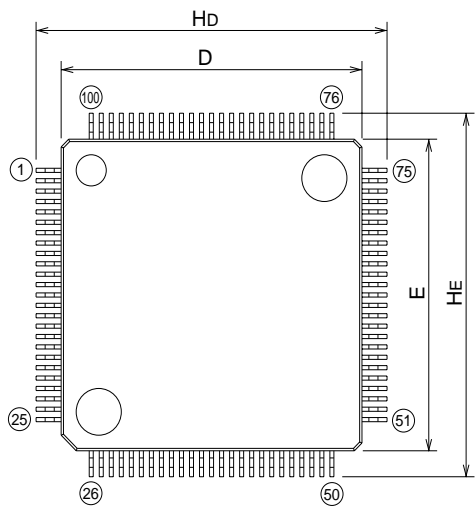

Recommended Mount Pad

Symbol	Dimension in Millimeters		
	Min	Nom	Max
A	-	-	1.2
A1	0.05	0.1	0.15
A2	-	1.0	-
b	0.13	0.18	0.23
c	0.105	0.125	0.175
D	11.9	12.0	12.1
E	11.9	12.0	12.1
e	-	0.4	-
Hd	13.8	14.0	14.2
HE	13.8	14.0	14.2
L	0.4	0.5	0.6
L1	-	1.0	-
Lp	0.45	0.6	0.75
A3	-	0.25	-
x	-	-	0.07
y	-	-	0.08
θ	0°	-	10°
b2	-	0.225	-
l2	1.0	-	-
MD	-	12.4	-
ME	-	12.4	-

Differences between M16C/62N and M16C/62M

Differences between M16C/62N and M16C/62M(Note)

Item	M16C/62N	M16C/62M
Shortest instruction execution time	62.5ns (f(XIN)=16MHz, VCC=3.0V to 3.6V) 142.9ns (f(XIN)=7MHz, VCC=2.4V to 3.6V without software wait)	100ns (f(XIN)=10MHz, VCC=2.7V to 3.6V) 142.9ns (f(XIN)=7MHz, VCC=2.2V to 3.6V with software one-wait)
Supply voltage	3.0V to 3.6V (f(XIN)=16MHz, without software wait) 2.4V to 3.0V (f(XIN)=7MHz, without software wait) 2.2V to 3.0V (f(XIN)=7MHz, with software one-wait) :mask ROM version	2.7V to 3.6V (f(XIN)=10MHz, without software wait) 2.4V to 2.7V (f(XIN)=7MHz, without software wait) 2.2V to 2.4V (f(XIN)=7MHz with software one-wait)
Low power consumption	34.0mW (VCC = 3V, f(XIN)=10MHz, without software wait) 66.0mW (VCC = 3.3V, f(XIN)=16MHz, without software wait)	28.5mW (VCC = 3V, f(XIN)=10MHz, without software wait)
Memory area	Memory area expansion (4 Mbytes)	1 Mbytes fixed
Clock Generating Circuit	Main clock division rate when main clock is stopped: Division by 8 mode	Main clock division rate when main clock is stopped: Does not change
Watchdog timer	Watchdog timer interrupt or reset is selected	Watchdog timer interrupt
Serial I/O (IIC bus mode)	Only digital delay is selected as SDA delay	Analog or digital delay is selected as SDA delay
A-D converter	10 bits X 8 channels Expandable up to 18 channels	10 bits X 8 channels Expandable up to 10 channels

Note: About the details and the electric characteristics, refer to data sheet.

Differences in SFR between M16C/62N and M16C/62M

Address	Register name	M16C/62N	M16C/62M
000516	Processor mode register 1 (PM1)	b5,b4 Memory area expansion bits b2 Watchdog timer function select bit	b5,b4 Reserved bits b2 Nothing is assigned
000B16	Data bank register (DBR)	Have	Reserved register
037716	UART2 special mode register (U2SMR)	b7 SDA digital delay select bit ("1" when reset)	b7 SDA digital delay select bit ("0" when reset)
03D416	A-D control register 2 (ADCON2)	b2, b1 Analog input group select bit b0 A-D conversion method select bit	b2,b1 Reserved bits b0 Reserved bit
03B416	Flash identification register (FIDR)	Have	Reserved register
03B616	Flash memory control register 1 (FMR1)	Reserved register	Have
03B716	Flash memory control register 0 (FMR0)	b7 Erase status flag b6 Program status flag	b7 Nothing is assigned b6 Nothing is assigned

REVISION HISTORY

M16C/62N GROUP DATA SHEET

Rev.	Date	Description	
		Page	Summary
1.0	29/05/02	6 14 67 206	Table 1.1.2 Delete "***" Figure 1.5.1 Add "More than...needed" (3) The NMI interrupt Line 12 is partly revised. ROM code protect Line 6 to 9 Delete "ROM code...selected by default." Figure 1.30.1 is partly revised.
1.1	30/08/02	1, 5 3 6 7 47 244	DMAC trigger:24 sources -->25 sources 100PFB-A package is added. Figure 1.1.4 and table 1.1.2 are partly revised. Figure 1.1.5 is partly revised. Figure 1.11.5 is partly revised. 100PFB-A package outline is added.



MITSUBISHI ELECTRIC CORPORATION

HEAD OFFICE: 2-2-3, MARUNOUCHI, CHIYODA-KU, TOKYO 100-8310, JAPAN

Keep safety first in your circuit designs!

- Mitsubishi Electric Corporation puts the maximum effort into making semiconductor products better and more reliable, but there is always the possibility that trouble may occur with them. Trouble with semiconductors may lead to personal injury, fire or property damage. Remember to give due consideration to safety when making your circuit designs, with appropriate measures such as (i) placement of substitutive, auxiliary circuits, (ii) use of non-flammable material or (iii) prevention against any malfunction or mishap.

Notes regarding these materials

- These materials are intended as a reference to assist our customers in the selection of the Mitsubishi semiconductor product best suited to the customer's application; they do not convey any license under any intellectual property rights, or any other rights, belonging to Mitsubishi Electric Corporation or a third party.
- Mitsubishi Electric Corporation assumes no responsibility for any damage, or infringement of any third-party's rights, originating in the use of any product data, diagrams, charts, programs, algorithms, or circuit application examples contained in these materials.
- All information contained in these materials, including product data, diagrams, charts, programs and algorithms represents information on products at the time of publication of these materials, and are subject to change by Mitsubishi Electric Corporation without notice due to product improvements or other reasons. It is therefore recommended that customers contact Mitsubishi Electric Corporation or an authorized Mitsubishi Semiconductor product distributor for the latest product information before purchasing a product listed herein.
The information described here may contain technical inaccuracies or typographical errors. Mitsubishi Electric Corporation assumes no responsibility for any damage, liability, or other loss rising from these inaccuracies or errors. Please also pay attention to information published by Mitsubishi Electric Corporation by various means, including the Mitsubishi Semiconductor home page (<http://www.mitsubishichips.com>).
- When using any or all of the information contained in these materials, including product data, diagrams, charts, programs, and algorithms, please be sure to evaluate all information as a total system before making a final decision on the applicability of the information and products. Mitsubishi Electric Corporation assumes no responsibility for any damage, liability or other loss resulting from the information contained herein.
- Mitsubishi Electric Corporation semiconductors are not designed or manufactured for use in a device or system that is used under circumstances in which human life is potentially at stake. Please contact Mitsubishi Electric Corporation or an authorized Mitsubishi Semiconductor product distributor when considering the use of a product contained herein for any specific purposes, such as apparatus or systems for transportation, vehicular, medical, aerospace, nuclear, or undersea repeater use.
- The prior written approval of Mitsubishi Electric Corporation is necessary to reprint or reproduce in whole or in part these materials.
- If these products or technologies are subject to the Japanese export control restrictions, they must be exported under a license from the Japanese government and cannot be imported into a country other than the approved destination.
Any diversion or reexport contrary to the export control laws and regulations of Japan and/or the country of destination is prohibited.
- Please contact Mitsubishi Electric Corporation or an authorized Mitsubishi Semiconductor product distributor for further details on these materials or the products contained therein.