

PART NUMBER		TAB SIZE	WIRE RANGE AWG (mm ²)	HOUSING COLOR	MAX INSUL DIA	DIMENSIONS in		
PREFIX	PKG					A $\pm .03$ (0.8)	B $\pm .01$ (0.3)	C $\pm .01$ (0.3)
DNF18-206	-C -M	.205 x .020 (5.2 x 0.5)	22-18 (.38-1.0)	RED	.137 (3.48)	.76 (19.3)	.25 (6.4)	.12 (3.0)
DNF14-206	-C -M	.205 x .020 (5.2 x 0.5)	16-14 (1.5-2.5)	BLUE	.162 (4.11)	.76 (19.3)	.25 (6.4)	.12 (3.0)

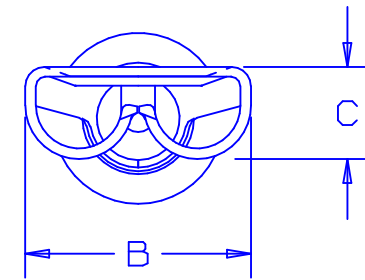

NOTES:

- UL LISTED AND CSA CERTIFIED FOR:
 - A. 300V. MAX. VOLTAGE RATING
 - B. STRANDED COPPER WIRE ONLY
 - C. 194° F (90° C) MAX. TEMP. RATING
- PACKAGE QTY: STD. PKG. -C= 100
BULK PKG. -M= 1000
- MATERIAL:
 - A. STAMPING: .016 (0.41) THK BRASS, TIN PLATED
 - B. SLEEVE: BRASS, TIN PLATED
 - C. HOUSING: NYLON
- WIRE STRIP LENGTH $9/32 \begin{matrix} +1/32 \\ -0 \end{matrix}$ (7.1 $\begin{matrix} +0.8 \\ -0 \end{matrix}$)
- INITIAL INSERTION FORCE - 12 LB. (53 N) MAX
INITIAL WITHDRAWAL FORCE - 12 LB. (53 N) MAX
6 LB. (27 N) MIN
- INSTALLATION TOOLS:
 - A. UL LISTED AND CSA CERTIFIED: CT-500
 - B. PANDUIT APPROVED: CT-100, CT-160, CT-260, CT-400, CT-460 (FOR DNF14-187 ONLY), CT-550, CT-1550, CT-1551.
- DIMENSIONS IN BRACKETS ARE IN MILLIMETERS OR mm²

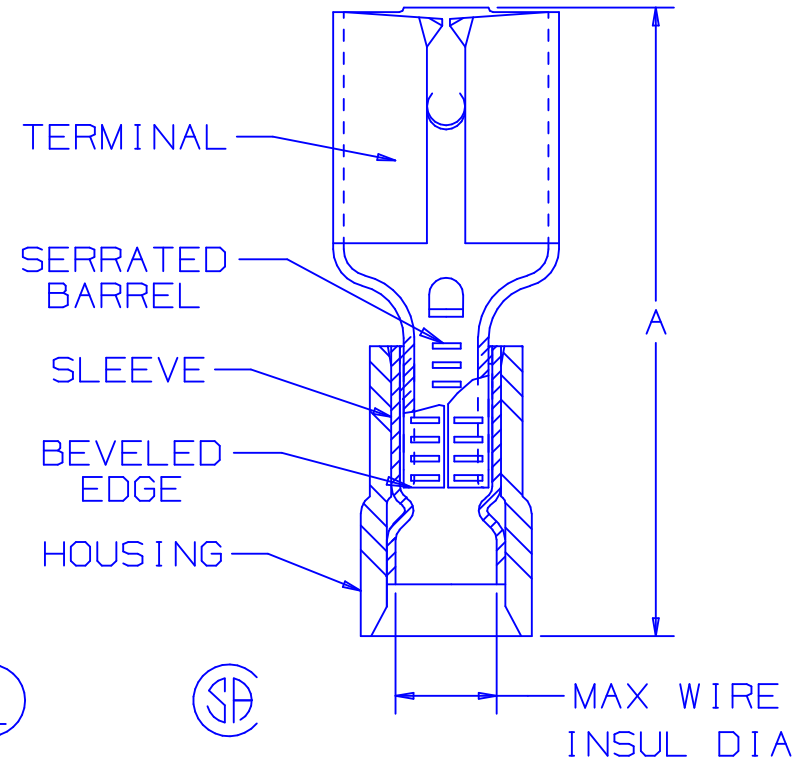

LISTED
20H3
E78522

CERTIFIED
LR31212

A41586_02

02	7/03	KLFU		ADD INTERNAL SERRATIONS REMOVED SLOTS						<p>TINLEY PARK, ILLINOIS</p> <p>NYLON INSULATED FEMALE DISCONNECT, FUNNELED WIRE ENTRY (.206 SERIES)</p>			
01	1/01	RM	SKB	FILESPEC WAS N41586AA_PCD_00	08933		JAC	CCH					
00	1/96	ED		RELEASED	03871								
REV	DATE	BY	CHK	DESCRIPTION	ECN #	QA	CUST	PM	APP	DRAWN BY	CHK'D	SCALE	DRAWING NO.
										EJD		NONE	A41586