

MN7130

MULTIPLEXED
TRACK-HOLD
AMPLIFIER



MICRO NETWORKS

FEATURES

- Complete DAS Front End:
2 8-Channel Multiplexers
Instrumentation Amp
Track-Hold Amp
- Small 32-Pin DIP
- 12-Bit Linearity
- 16 Single-Ended or 8
Differential Input Channels
- 10 μ sec Maximum
Acquisition Time
to $\pm 0.01\%$ (20V Step)
- Low Droop Rate
 $\pm 7\mu V/\mu$ sec Maximum
- Full Mil Operation
-55°C to +125°C
- MIL-H-38534 Screening
Optional. MIL-STD-1772
Qualified Facility

32 PIN DIP

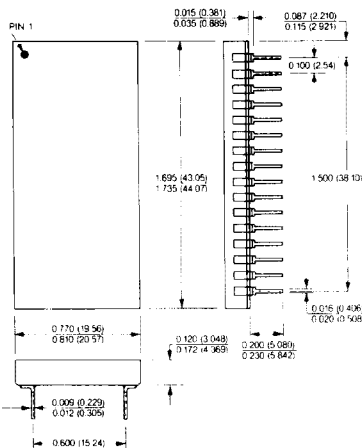

Dimensions in Inches
(millimeters)

DESCRIPTION

MN7130 is a thin-film hybrid circuit containing two 8-channel multiplexers, a true instrumentation amplifier and a track-hold amplifier. This unique circuit is extremely versatile and can be used in conjunction with any of Micro Networks analog-to-digital converters to configure a complete, 16-channel (8 full differential) data acquisition system in as few as 2 dual-in-line packages occupying as little as 4 square inches of board space. Additionally, MN7130 can be used in any analog system for applications requiring the analog acquisition of multiple channels.

MN7130 has a maximum acquisition time of 10 μ sec (20V step to $\pm 0.01\%$ FSR) when the multiplexer, instrumentation amplifier and track-hold are serially connected, and a typical droop rate of $\pm 4\mu V/\mu$ sec. The internal multiplexer may be connected for single-ended or 8 full differential input channels and is directly addressable in binary. The digital inputs are CMOS compatible, and analog inputs up to $\pm 10V$ can be accommodated. For additional flexibility, all inputs and outputs of the internal subsections are available at the device pins. The standard device is fully specified for either 0°C to +70°C or -55°C to +125°C (H model) operation. The MN7130H/B is available with Environmental Stress Screening while the MN7130H/B CH is fully screened in accordance with MIL-H-38534.

MN7130 was specifically designed to fill the need for a small, low-cost data acquisition system that was physically and electrically compatible with current microprocessor technology. When used with a 12-bit A/D, the approach eliminates the need for special mountings and connectors, saves space, facilitates maintenance, and reduces costs. In addition, MN7130 allows standard board spacing, improves reliability and offers significant weight savings in aerospace and avionics applications.



MICRO NETWORKS

324 Clark St., Worcester, MA 01606 (508) 852-5400

January 1992
Copyright 1992
Micro Networks
All rights reserved

MN7130

MN7130 MULTIPLEXED TRACK-HOLD AMPLIFIER

ABSOLUTE MAXIMUM RATINGS

Operating Temperature Range	-55°C to +125°C
Specified Temperature Range:	
MN7130	0°C to +70°C
MN7130H, H/B	-55°C to +125°C
Storage Temperature Range	-65°C to +150°C
Positive Supply (+V _{CC} , Pin 24)	0 to +16 Volts
Negative Supply (-V _{CC} , Pin 23)	0 to -16 Volts
Multiplexer Inputs (Pins 1-16)	-V _{CC} to +V _{CC}
Instrumentation Amp Inputs (Pins 21, 22)	±15 Volts
T/H Amplifier Input (Pin 19)	0 to ±V _{CC} Volts
Address Inputs (Pins 27-31)	-0.3 to +V _{CC} Volts
T/H Command (Pin 17)	0 to +7 Volts
Multiplexer Outputs (Pins 26, 32)	±20mA
Instrumentation Amp Output (Pin 20)	±25mA
T/H Amplifier Output (Pin 18)	S.C. Protected to Ground

ORDERING INFORMATION

PART NUMBER _____ **MN7130/H/B CH**

Standard part is specified for 0°C to +70°C operation.

Add "H" for specified -55°C to +125°C operation.

Add "B" to "H" models for Environmental Stress Screening.

Add "CH" to "B" models for 100% screening according to MIL-H-38534.

SYSTEM SPECIFICATIONS (T_A = +25°C, ±V_{CC} = ±15V, unless otherwise indicated) (Note 1)

ANALOG INPUT (Multiplexer Inputs)	MIN.	TYP.	MAX.	UNITS
Voltage Range: Single-Ended		±10		Volts
Differential		±10		Volts
Common Mode	±10	±12		Volts
Input Impedance		250/100		MΩ/pF
Input Current		±15	±30	nA
Common Mode Rejection Ratio	70	80		dB
DIGITAL INPUTS (Mux Address, T/H Command)				
Logic Levels: Mux Address: Logic "1"	+4.0			Volts
Logic "0"			+0.8	Volts
T/H Command: Logic "1"	+2.4			Volts
Logic "0"			+0.8	Volts
Logic Currents: Mux Address (Note 2):				
Logic "1" (V _{IH} = +5.0V)		±10		μA
Logic "0" (V _{IL} = +0.0V)		±10		μA
T/H Command: Logic "1" (V _{IH} = +2.4V)		±10		μA
Logic "0" (V _{IL} = +0.4V)		±10		μA
ANALOG OUTPUT (T/H Amplifier)				
Output Voltage	±10			Volts
Output Current	±2			mA
Output Load Capacitance			50	pF
TRANSFER CHARACTERISTICS				
Gain		+1		V/V
Gain Error (Note 3): Initial (+25°C)		±0.1		%
Over Temperature (Note 4)		±0.1	±0.2	%
Gain Linearity Error (Note 5)		±0.002		%FSR
Offset Voltage (Track Mode): Initial (+25°C)		±2		mV
Over Temperature (Note 4)		±4	±6	mV
Offset Change (Pedestal, Hold Mode)				
Over Temperature (Note 4)		±15		mV
Droop Rate: +25°C		±4	±7	μV/μsec
0°C to +70°C			±10	μV/μsec
-55°C to +125°C			±40	μV/μsec

DYNAMIC CHARACTERISTICS	MIN.	TYP.	MAX.	UNITS
Large Signal Bandwidth		250		kHz
Output Slew Rate		± 20		V/μsec
Acquisition Time (20V step to ± 0.01%)		6.5	10	μsec
Aperture Delay		200	400	nsec
Settling Time, Track-to-Hold to ± 1.0mV		0.5	2	μsec
Feedthrough (Hold Mode) @ 1kHz		± 0.01		%
Transients Peak Amplitude: Track-to-Hold Hold-to-Track		90 100		mV mV
POWER SUPPLIES				
Power Supply Range: + 15V Supply - 15V Supply	+ 14.55 - 14.55	+ 15 - 15	+ 15.45 - 15.45	Volts Volts
Current Drains: + 15V Supply - 15V Supply		+ 30 - 30	+ 40 - 40	mA mA
Power Consumption		900	1200	mW

SPECIFICATION NOTES:

- System specifications listed reflect system performance with all elements serially connected.
- If the multiplexer inputs are to be driven from standard TTL logic, 1kΩ pullup resistors to +5V should be connected.
- Gain error is defined as the error in the slope of the systems input-output transfer function and is expressed in percent.
- MN7130 is specified for 0°C to +70°C operation. MN7130H and MN7130H/B are specified for -55°C to +125°C operation.
- Gain linearity error is defined as the maximum deviation from the best-fit straight line approximation to the system's input-output transfer function and is expressed as a percentage of the system's full scale voltage swing (FSR).

BLOCK DIAGRAM

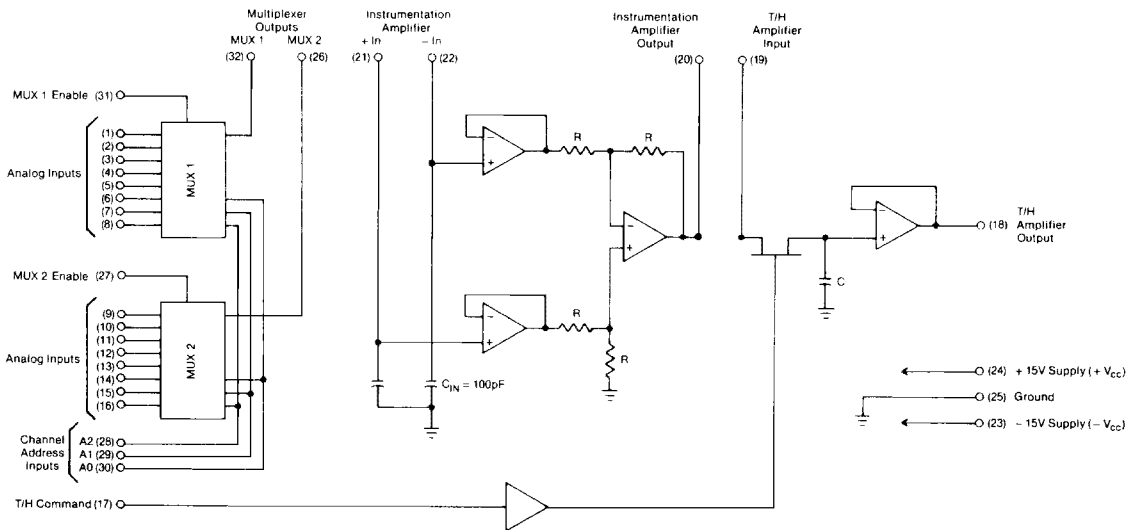

MN7130

PIN DESIGNATIONS

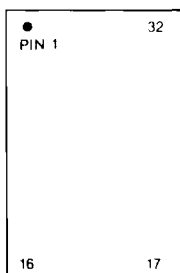

1 Channel 0	32 Mux 1 Output
2 Channel 1 Enable	31 Mux 1 Enable
3 Channel 2	30 A ₀ Mux Address
4 Channel 3	29 A ₁ Mux Address
5 Channel 4	28 A ₂ Mux Address
6 Channel 5	27 Mux 2 Enable
7 Channel 6	26 Mux 2 Output
8 Channel 7	25 Ground
9 Channel 8	24 +15V Supply (+V _{CC})
10 Channel 9	23 -15V Supply (-V _{CC})
11 Channel 10	22 -In (Instrumentation Amplifier)
12 Channel 11	21 +In (Instrumentation Amplifier)
13 Channel 12	20 Instrumentation Amplifier Output
14 Channel 13	19 T/H Amplifier Input
15 Channel 14	18 T/H Amplifier Output
16 Channel 15	17 T/H Command

APPLICATIONS INFORMATION

DESCRIPTION OF OPERATION—MN7130 is a complete data acquisition system front end containing user-configurable components (multiplexers, instrumentation amplifier and track/hold amplifier).

In order to preserve maximum flexibility, all inputs and outputs of the subsections are available at the device pins. The internal 8-channel multiplexers can be connected for 16 single-ended or 8 fully differential input operation and may be directly addressed via three address lines and two mux enable lines. The internal instrumentation amplifier offers high input impedance (250M Ω /100pF) and 70dB common mode rejection ratio. The internal track-hold amplifier completes this analog front-end function allowing dynamic input signals to be acquired and then held for analog-to-digital conversion.

MN7130 can be used in conjunction with MN574A μ P-compatible 12-bit A/D converters to configure a complete and inexpensive, 16-channel, 12-bit μ P-compatible DAS capable of 28,000 channels/sec throughput rates in a minimum of board space. Substituting MN5240 for MN574A increases throughput to 60,000 channels/sec.

LAYOUT CONSIDERATIONS—Proper attention to layout and decoupling is necessary to obtain specified performance from the MN7130. The unit's ground pin (pin 25) should be tied to system analog ground as close to the unit as possible, preferably through a large analog ground plane underneath the package.

Coupling between analog inputs and digital signals should be minimized to avoid noise pick-up. Care should be taken to avoid long runs or analog runs close to digital lines.

Power supply connections should be short and direct, and all power supplies should be decoupled with high-frequency bypass capacitors to ground. 1 μ F tantalum capacitors in parallel with 0.01 μ F ceramic capacitors are the most effective combination. Single 1 μ F ceramic capacitors can be used if necessary to save board space.

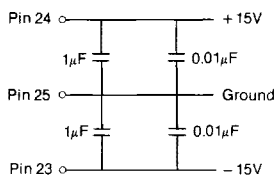

MULTIPLEXER-INSTRUMENTATION AMPLIFIER—The multiplexer section of the MN7130 is addressed with a three or four bit binary word and can be configured for 8 full differential inputs or 16 single-ended inputs. The use of differential inputs provides high rejection of common mode noise and elimination of ground return offsets. Differential inputs must be used when both sides of the input signal are off ground. Connections and truth tables for both modes of operation are shown on the following pages.

Approximately 1 μ sec access time should be allowed after addressing before the analog outputs of the multiplexer are used. A particular point to note is the minimum logic "1" for the multiplexer inputs is +4.0V. If the multiplexer inputs are to be driven from standard TTL logic, 1k Ω pullup resistors to +5V should be used.

The following diagrams show typical connections for both full differential and single-ended applications along with truth tables which demonstrate multiplexer address (A₀, A₁, A₂) and enable (Mux₁ Enable, Mux₂ Enable) line functions.

MN7130 is specified and tested as a system (all elements serially connected). Typical specifications for the multiplexer and instrumentation amplifier appear below.

Typical Mux Performance Specifications	
Numbers of Channels	16 Single-Ended 8 Full Differential
Input Voltage Range	$\pm 10V$
Input Impedance	250M Ω /100pF
Logic Levels: Logic "1" (min.) Logic "0" (max.)	+4.0V +0.8V
Logic Currents: Logic "1" Logic "0"	$\pm 10\mu A$ $\pm 10\mu A$
Access Time	500nsec
On Resistance	2k Ω
Cross Talk (1k Ω Source, 1kHz, 20vp-p)	-68dB

Typical Instrumentation Amplifier Performance Specifications	
Voltage Range	± 10V
Input Impedance	250MΩ/100pF
Input Current (max.)	± 30nA
Common Mode Rejection Ratio (min.)	70dB
Gain	+ 1V/V
Gain Error: Initial (+ 25 °C) Over Temperature	± 0.02% ± 0.05%
Gain Nonlinearity	± 0.002%
Large Signal Bandwidth	250kHz
Output Slew Rate	± 20V/μsec
Settling Time (20V Step to ±0.01%)	4μsec
Output Voltage Swing (min.)	± 10V
Output Current (min.)	± 2mA
Output Load Capacitance (max.)	50pF

TRACK-HOLD AMPLIFIER—The track-hold amplifier is in the hold mode when the T/H command is a logic "1" and in the sample mode when the T/H command is a logic "0". A total of 10μsec should be allowed after addressing the multiplexer before the T/H is commanded to the hold mode to allow for full scale (20V) changes. Maximum acquisition times for changes less than full scale are shown on the following page.

In data acquisition applications, the T/H command input can usually be driven directly from the A/D converter Status (E.O.C.) output.

As stated earlier, the MN7130 is specified and tested as a system (all elements serially connected). Typical T/H amplifier specifications are listed below.

Typical T/H Amplifier Performance Specifications	
Voltage Range	± 10V
Input Impedance	10 ¹⁰ Ω
Input Bias Current	± 15nA
Logic Levels: Logic "1" (min.) Logic "0" (max.)	+2.4V +0.8V
Logic Currents: Logic "1" Logic "0"	± 10μA ± 10μA
Gain	+ 1V/V
Gain Nonlinearity: Initial (+ 25 °C) Over Temperature	± 0.002% ± 0.005%
Offset Voltage (Track Mode): Initial (+ 25 °C) Over Temperature	± 2mV ± 4mV
Offset Change (Pedestal, Hold Mode) Over Temperature	± 15mV
Droop Rate: Initial (25 °C) (max.) 0 °C to + 70 °C (max.) - 55 °C to + 125 °C (max.)	± 7μV/μsec ± 10μV/μsec ± 40μV/μsec
Acquisition Time (20V Step to ± 0.01%) (max.)	10μsec
Aperture Time (max.)	400nsec
Feedthrough (Hold Mode) @ 1kHz	± 0.01%
Transients Peak Amplitude: Track-to-Hold Hold-to-Track	90mV 100mV

MULTIPLEXER CONNECTIONS and ADDRESSING

16 Single Ended Input Channels

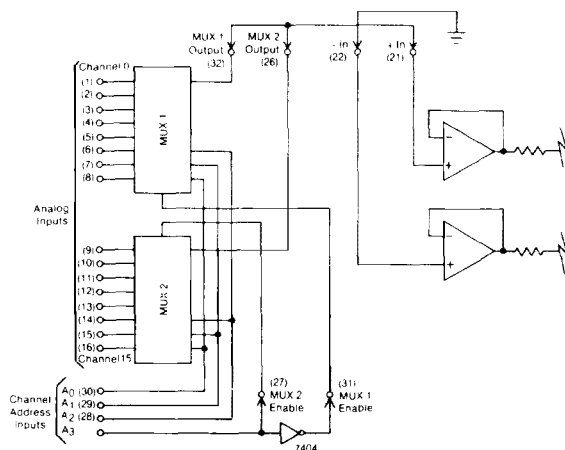

Address Inputs			Enable Inputs		On Channel
A ₂	A ₁	A ₀	MUX 1	MUX 2	
X	X	X	1	1	ILLEGAL
X	X	X	0	0	NONE
0	0	0	1	0	0
0	0	1	1	0	1
0	1	0	1	0	2
0	1	1	1	0	3
1	0	0	1	0	4
1	0	1	1	0	5
1	1	0	1	0	6
1	1	1	1	0	7
0	0	0	0	1	8
0	0	1	0	1	9
0	1	0	0	1	10
0	1	1	0	1	11
1	0	0	0	1	12
1	0	1	0	1	13
1	1	0	0	1	14
1	1	1	0	1	15

Logic "1" > +4.0V
Logic "0" < +0.8V

8 Differential Input Channels

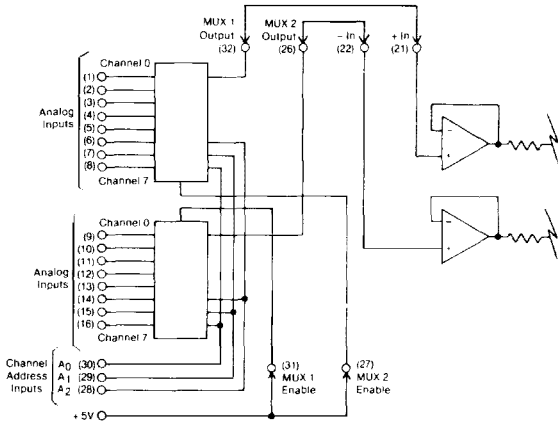

Address Inputs			Enable Inputs		On Channel
A ₂	A ₁	A ₀	MUX 1	MUX 2	
X	X	X	0	1	ILLEGAL
X	X	X	1	0	ILLEGAL
X	X	X	0	0	NONE
0	0	0	1	1	0
0	0	1	1	1	1
0	1	0	1	1	2
0	1	1	1	1	3
1	0	0	1	1	4
1	0	1	1	1	5
1	1	0	1	1	6
1	1	1	1	1	7

Logic "1" > +4.0V
 Logic "0" < +0.8V

MN7130
 Acquisition Time
 vs. Output Swing

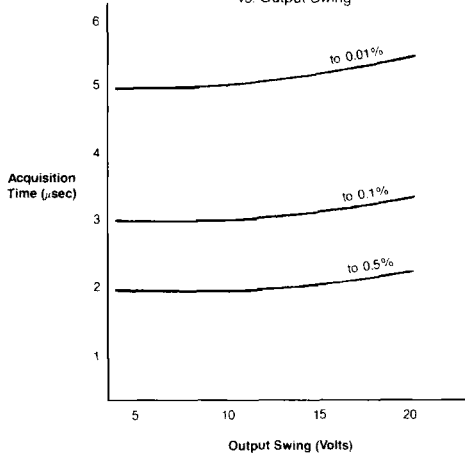

MN7130
 Common Mode Rejection
 vs. Frequency

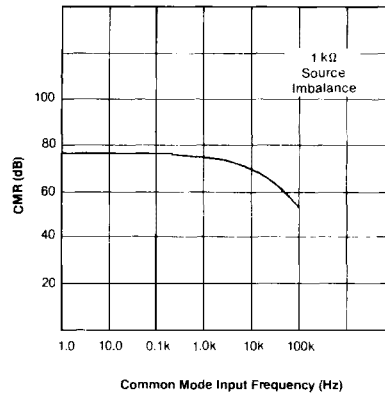

MICRO NETWORKS

324 Clark St., Worcester, MA 01606 (508) 852-5400