

TMC2301

Image Resampling Sequencer

15, 18, 20 MHz

Features

- Rotation, warping, panning, zooming, and compression of images in real time
- 20 MHz clock rate
- 4096 x 4096 image field addressing capability
- User-selectable nearest-neighbor, bilinear interpolation, and cubic convolution resampling algorithms
- Static convolutional filtering of up to 16 x 16 pixel windows
- Single-pass or two-pass convolution operations
- Low power consumption CMOS process
- Single 5V power supply
- Available in a 68-pin grid array and low-cost plastic leaded chip carrier (J-bend)

Applications

- Video special-effects generators
- Image recognition systems, robotics
- Artificial intelligence
- High-precision image registration (LANDSAT processing)
- High-speed data encoding/decoding
- General purpose image processing
- Image data compression

Description

The TMC2301 is a VLSI circuit which supports image resampling, rotation, rescaling and filtering by generating input bit plane, interpolation coefficient lookup table, and output bit plane memory addresses along with external multiplier-accumulator control signals. The TMC2301 can process data fields of up to 4096 x 4096 multibit words at a clock rate of up to 20 MHz. An Image Resampling

Sequencer (IRS) based system can nearest-neighbor resample a 512 x 512 image in 15 milliseconds, translating, zooming, rotating, or warping it, depending on the transform parameter set loaded. A complete bilinear interpolation of the same image can be completed in 60 milliseconds. Image resampling speed is independent of the angle of rotation, degree of warp, or amount of zoom specified.

Logic Symbol

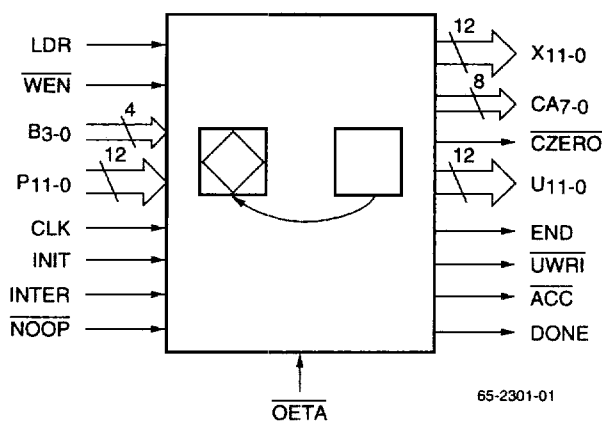

A high performance, TMC2301-based system can execute bilinear and cubic convolution algorithms that rotate images accurately and in real time. Keystone or other perspective correction, image plane distortion, and numerous other second order polynomial transformations can be programmed and executed under direct user control. Direct access to the interpolation coefficient lookup table allows dynamic modification of the algorithm.

Following an initialization with the transform parameters and control bits defining the operation to be executed, the IRS assumes control of the input and output data fields and executes unattended. All inputs except INTER and all outputs are registered on the rising edge of clock. All outputs are three-state controlled except ACC, CZERO, END, and DONE.

Fabricated in a 1 micron CMOS process, the TMC2301 operates at clock rates of up to 20 MHz over the full commercial (0 to 70°C) temperature and supply voltage ranges, and at 15 MHz over the extended (-55 to +125°C) temperature and supply voltage ranges. All signals are TTL compatible.

RAYTS071*

Block Diagram

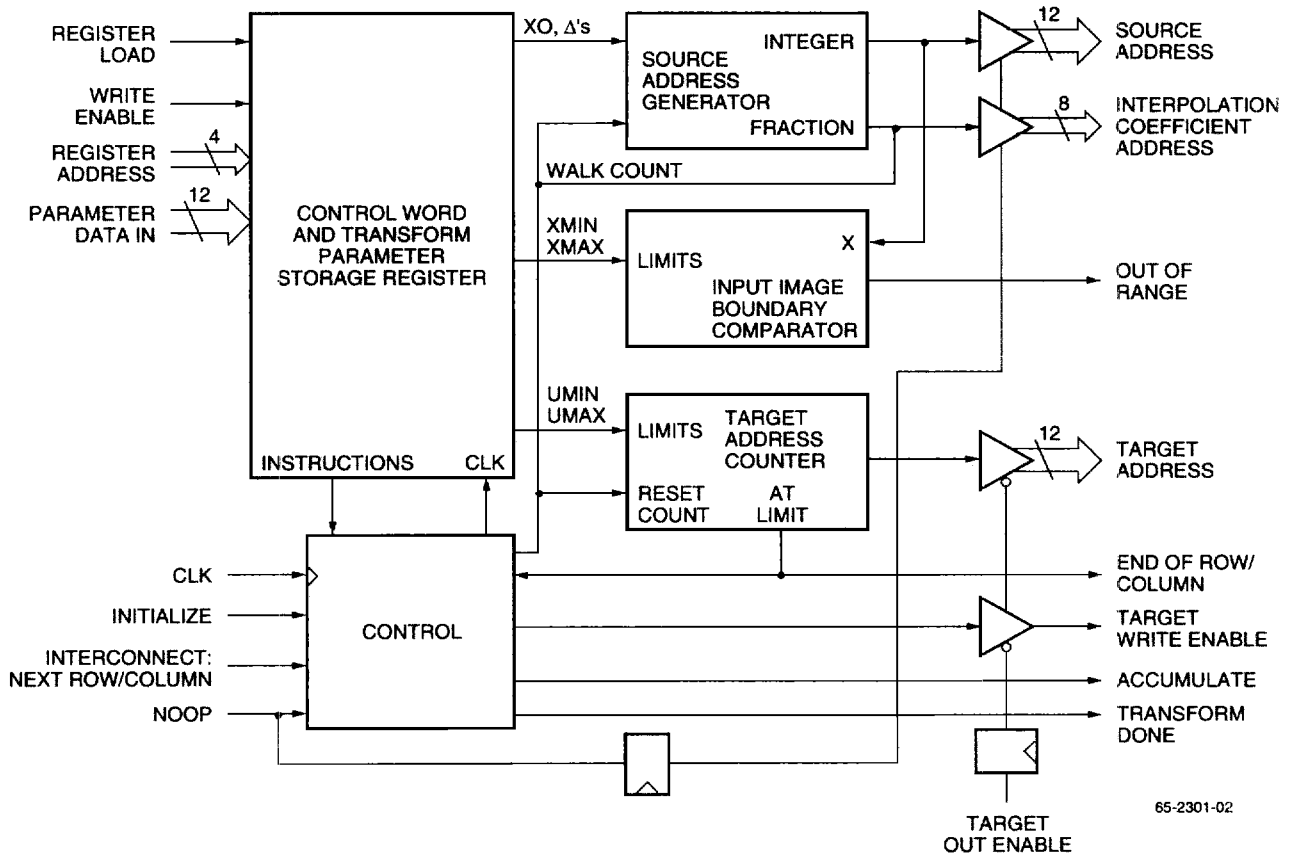

65-2301-02

Functional Description

General Information

The IRS is a versatile self-sequencing address generator designed primarily to filter a two-dimensional image or to remap and resample it from one set of Cartesian coordinates (x, y) into a new transformed set (u, v). Most applications use two identical devices in tandem, one generating the row coordinates (X and U), the other generating the column coordinates (Y and V). The algorithm performed by the TMC2301 consists of two steps: a coordinate system transformation, followed by pixel interpolation. Interpolation is necessary when the transformed pixel positions (U, V) do not coincide with the original pixel positions (X, Y). The new pixel intensity values are obtained by interpolating the original pixels in the neighborhood of the transformed pixel positions. See Figure 1.

The IRS executes a general second order coordinate transformation of the form:

$$X(u, v) = Au^2 + Bu + Cuv + Dv^2 + Ev + F$$

$$Y(u, v) = Gu^2 + Hu + Kuv + Lv^2 + Mv + N$$

where A through N are user-defined parameters. It steps sequentially through the pixels of a user-defined rectangle in

the new set of coordinates, computing the "old" address (X, Y) corresponding to each "new" location (U, V).

The TMC2301 uses the external multiplier-accumulator, connected to the system clock, to calculate the interpolated pixel value by summing the products of the original pixel values stored in the source buffer RAM and the appropriate weights from the polynomial transform lookup table. The new interpolated image value is then stored in the corresponding (U, V) memory location. Finally, the new image address is incremented by one pixel in the "U" direction or reset to the start of the next line (with "V" incremented) proceeding line-by-line through the entire destination image.

The TMC2301 can support any nearest neighbor, bilinear, or cubic resampling, according to the user's requirements. The bilinear and cubic kernels require a coefficient lookup table and multiplier-accumulator. Both one-pass and two-pass algorithms are supported. Sophisticated "walkaround" algorithms implementing static filters are also easily realized utilizing convolutional kernels of up to 16 x 16 pixels. For each output point in a typical static single-pass filter, the IRS will generate a series of addresses, "walking" around that point in two dimensions. At the end of each walk, it will advance one pixel along the output scan line, then begin the walk for the next pixel.

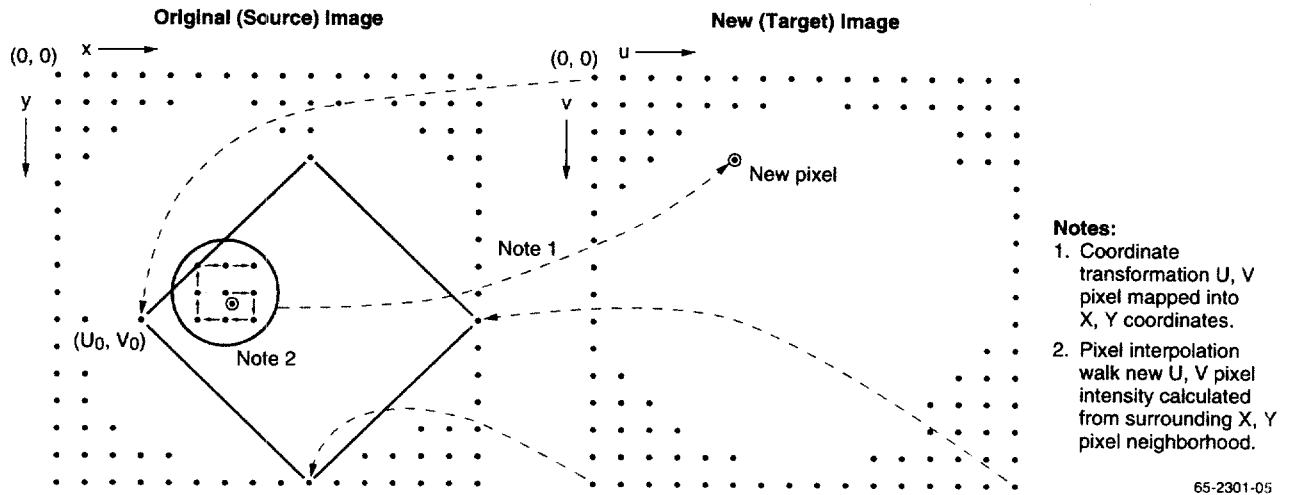

65-2301-05

Figure 1. Image Resampling Geometry Showing Image Rotation and Expansion

A basic TMC2301-based system is shown in Figure 2. In this typical system, two Image Resampling Sequencers process the image. The only other external parts needed are a

multiplier-accumulator, external interpolation coefficient lookup table RAM, and the user-specified Source and Destination Image Memory.

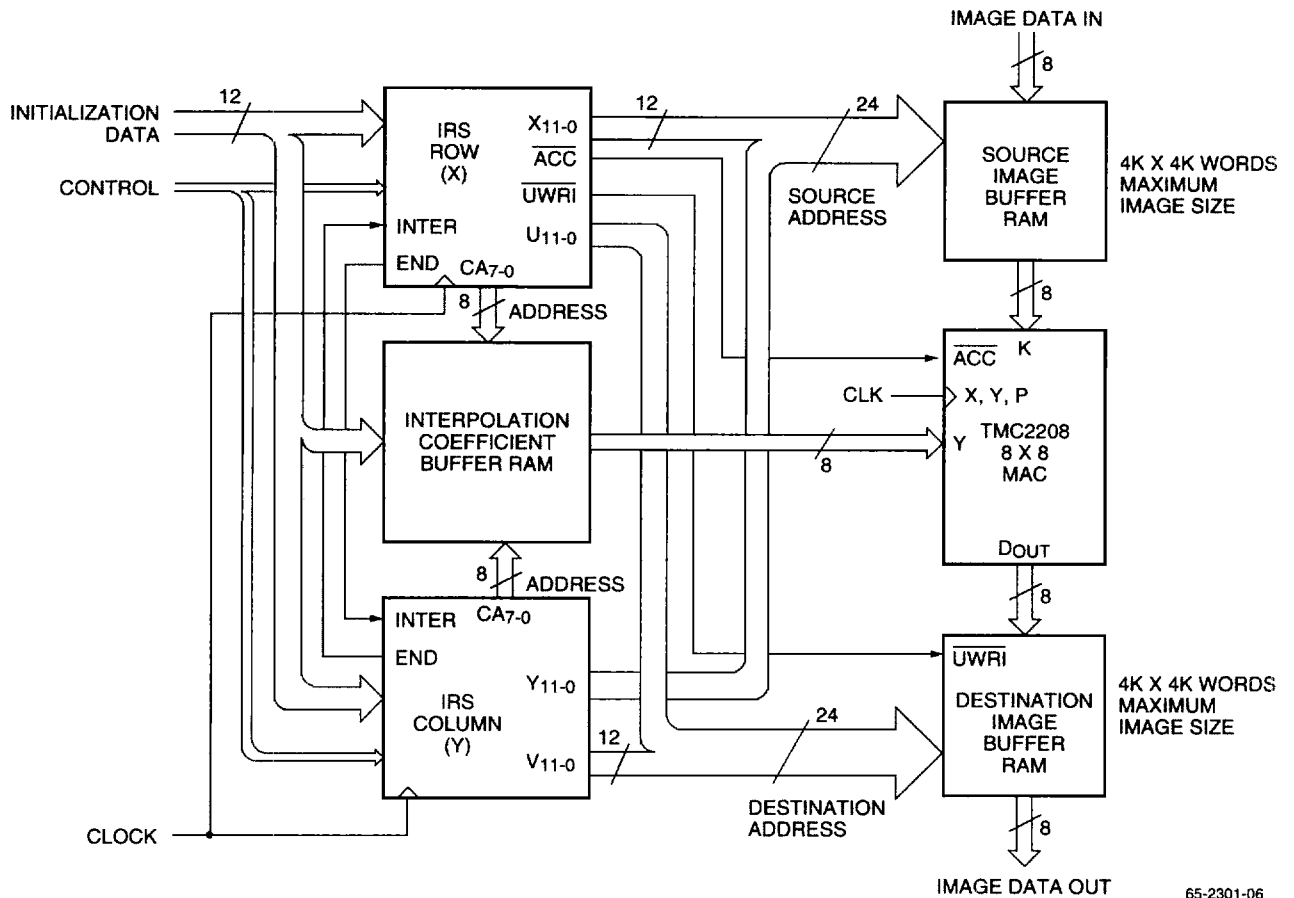

65-2301-06

Figure 2. Basic 2-D Image Convolver Using TMC2301 Image Resampling Sequencer Utilizing Typical 8-Bit Data Path

Pin Assignments

68 Pin Grid Array

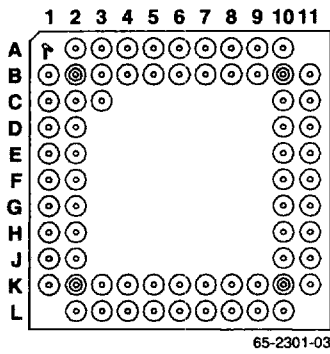

Pin	Name	Pin	Name	Pin	Name	Pin	Name
B2	INIT	K2	U ₁₀	K10	X ₁	B10	P ₆
B1	OETA	L2	U ₁₁	K11	X ₂	A10	P ₅
C2	INTER	K3	UWRI	J10	X ₃	B9	P ₄
C1	END	L3	ACC	J11	X ₄	A9	P ₃
D2	DONE	K4	CZERO	H10	X ₅	B8	P ₂
D1	U ₀	L4	CA ₀	H11	X ₆	A8	P ₁
E2	U ₁	K5	CA ₁	G10	X ₇	B7	P ₀
E1	U ₂	L5	VDD	G11	X ₈	A7	CLK
F2	GND	K6	GND	F10	GND	B6	GND
F1	U ₃	L6	CA ₂	F11	X ₉	A6	VDD
G2	U ₄	K7	CA ₃	E10	X ₁₀	B5	NOOP
G1	U ₅	L7	CA ₄	E11	X ₁₁	A5	LDR
H2	U ₆	K8	CA ₅	D10	P ₁₁	B4	B ₀
H1	U ₇	L8	CA ₆	D11	P ₁₀	A4	B ₁
J2	U ₈	K9	CA ₇	C10	P ₉	B3	B ₂
J1	U ₉	L9	X ₀	C11	P ₈	A3	B ₃
K1	GND	L10	GND	B11	P ₇	A2	WEN

68 Pin PLCC

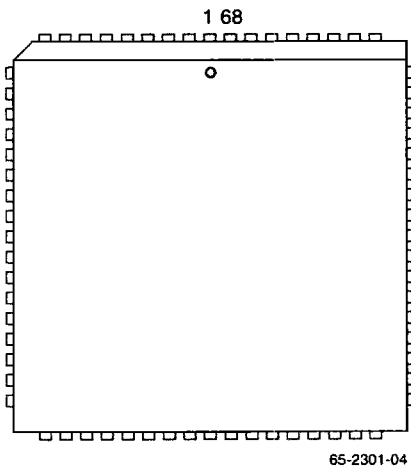

Pin	Name	Pin	Name	Pin	Name	Pin	Name
1	GND	18	GND	35	GND	52	GND
2	CA ₂	19	X ₉	36	VDD	53	U ₃
3	CA ₃	20	X ₁₀	37	NOOP	54	U ₄
4	CA ₄	21	X ₁₁	38	LDR	55	U ₅
5	CA ₅	22	P ₁₁	39	B ₀	56	U ₆
6	CA ₆	23	P ₁₀	40	B ₁	57	U ₇
7	CA ₇	24	P ₉	41	B ₂	58	U ₈
8	X ₀	25	P ₈	42	B ₃	59	U ₉
9	GND	26	P ₇	43	WEN	60	GND
10	X ₁	27	P ₆	44	INIT	61	U ₁₀
11	X ₂	28	P ₅	45	OETA	62	U ₁₁
12	X ₃	29	P ₄	46	INTER	63	UWRI
13	X ₄	30	P ₃	47	END	64	ACC
14	X ₅	31	P ₂	48	DONE	65	CZERO
15	X ₆	32	P ₁	49	U ₀	66	CA ₀
16	X ₇	33	P ₀	50	U ₁	67	CA ₁
17	X ₈	34	CLK	51	U ₂	68	VDD

Pin Descriptions

Pin Name	Pin Number		Pin Function Description
	PGA	PLCC	
Power			
GND	F2, F10, K1, K6, L10, B6	1, 9, 18, 35, 52, 60	Supply Voltage. The TMC2301 operates from a single +5V supply. All pins must be connected.
VDD	L5, A6	36, 68	Ground. The TMC2301 operates from a single +5V supply. All pins must be connected.
Clock			
CLK	A7	34	System Clock. The TMC2301 has a angle clock input. The rising edge of CLK strobes all enabled registers. All timing specifications are referenced to the rising edge of CLK.
Inputs			
B3-0	A3, B3, A4, B4	42-39	Parameter Register Address. The write addresses for the individual coordinate transform parameters are presented at the registered 4-bit B input port. B3 is the Most Significant Bit.
P11-0	D10, D11, C10, C11, B11, B10, A10, B9, A9, B8, A8, B7	22-33	Parameter Register Data. The coordinate transformation parameters are loaded through the registered 12-bit P input port. P11 is the Most Significant Bit.
Outputs			
CA7-0	K9, L8, K8, L7, K7, L6, K5, L4	7-2, 67, 66	Coefficient Address. The current interpolation kernel coefficient lookup table address is indicated by the registered 8-bit CA7-0 output bus. This output is forced to the high impedance state when $\overline{\text{NOOP}}$ is LOW. CA7 is the Most Significant Bit.
U11-0	L2, K2, J1, J2, H1, H2, G1, G2, F1, E1, E2, D1	62, 61, 59-53, 51-49	Target Address. The U (or V) target address of the image being generated is indicated by the registered 12-bit U11-0 output bus. This output is forced to the high impedance state when $\overline{\text{OETA}}$ is HIGH. U11 is the Most Significant Bit.
X11-0	E11, E10, F11, G11, G10, H11, H10, J11, J10, K11, K10, L9	21-19, 17-10, 8	Source Address. The current X (or Y) source pixel address of the image being resampled is indicated by the registered 12-bit X11-0 output bus. This output is forced to the high impedance state when $\overline{\text{NOOP}}$ is LOW. X11 is the Most Significant Bit.
Controls			
ACC	L3	64	Accumulate. The accumulation register of the external multiplier-accumulator is initialized by the registered ACC output. ACC goes LOW for one cycle at the start of each interpolation "walk," effectively clearing the storage register by loading in only the new first product. See Figure 9.
INIT	B2	44	Initialize. The control logic is cleared and initialized for the start of a new image transformation when the registered INIT input is HIGH for a minimum of two clock cycles. Normal operation begins after INIT goes LOW.
INTER	C2	46	Interconnect. In the common two-device system configuration, the Interconnect inputs are connected to the END flag outputs. The END flag from the row (X) sequencer thus indicates an "end of line" to the column (Y) device, while the column sequencer in turn sends a "bottom of frame" signal to the row device, forcing a reset of the address counter.

Pin Descriptions (continued)

Pin Name	Pin Number		Pin Function Description
	PGA	PLCC	
LDR	A5	38	Load Parameter Data Registers. The data held in all transformation parameter preload registers are latched into the working registers when the registered input LDR is HIGH. When LDR is LOW, the working parameters remain unchanged. See Figure 4.
$\overline{\text{NOOP}}$	B5	37	No Operation. The Clock is overridden when the registered input NOOP is LOW, holding each address generator in their current state. Also, the output buffers for the address busses X ₁₁₋₀ and CA ₇₋₀ are forced to the high impedance state. This allows the user access to all external memory. When $\overline{\text{NOOP}}$ goes HIGH, normal operation resumes on the next clock cycle.
$\overline{\text{OETA}}$	B1	45	Target Memory Output Enable. The target memory outputs $\overline{\text{UWRI}}$ and address bus U ₁₁₋₀ are in the high-impedance state when the registered Output Enable input is HIGH. When $\overline{\text{OETA}}$ is LOW, they are enabled on the next clock cycle.
UWRI	K3	63	Target Memory Write Enable. After the end of each interpolation "walk," the Target Memory (U or V) Write Enable goes LOW for one clock cycle. See Figure 9. This registered output is forced to the high impedance state when $\overline{\text{OETA}}$ is HIGH.
WEN	A2	43	Parameter Write Enable. The registered Write Enable input allows the transformation parameters to be written into the preload register indicated by the address at the B input port when LOW. See Figure 4.
Flags			
$\overline{\text{CZERO}}$	K4	65	Coefficient Zero. The registered $\overline{\text{CZERO}}$ flag of a horizontal dimension TMC2301 goes HIGH if $X < 0$, $X_{\text{MIN}} \leq X \leq X_{\text{MAX}}$, or $X \geq 4096$ (1000 hex). It goes LOW if $0 \leq X \leq X_{\text{MIN}}$ or $X_{\text{MAX}} < X < 4096$. The logical AND of the $\overline{\text{CZERO}}$ flags of a two-dimensional pair of TMC2301s will go LOW when the source address falls outside a rectangle with vertices (X _{MIN} , Y _{MIN}), (X _{MAX} , Y _{MIN}), (X _{MIN} , Y _{MAX}), and (X _{MAX} , Y _{MAX}), denoting an invalid address. The external data path can be wired to substitute a selected background value whenever this AND = 0.
DONE	D2	48	End of Transform. In the standard two-device system, a row sequencer DONE flag HIGH after the last walk at the end of the last row of an image (during UWRI LOW) indicates the end of the transform. This registered output is usually ignored on the column device. See the Transformation Control Parameters, AUTOINIT.
END	C1	47	End of Row/Page. The registered END flag goes HIGH during the last pixel of the last walk in a row in the case of the row chip, and the last pixel of the last walk in a column in the column chip, in the two-device architecture. This output is used as the end-of-line and end-of-frame indicator in conjunction with the INTER inputs of both TMC2301s.

Transformation Control Parameters

The TMC2301 is a self-sequencing device which requires no cycle-to-cycle intervention from the host system. To program the device, the user loads the 16 operating parameters, which define the transformation to be performed, which sections of the original and resampled image spaces are to be utilized, and various control words. Filtering operations are further defined by the values the user loads into the external coefficient memory. The transform parameters are described below. See also Tables 1 through 3.

XMIN, XMAX, YMIN, YMAX	These four parameters outline the "source" rectangular region of the original image. Whenever the IRS pair generates an (X, Y) address within this boundary the CZERO flags will denote a valid memory read. In the most common case, XMIN < XMAX, YMIN < YMAX, 000h < X < FFFh, and 000h < Y < FFFh. In this case, addresses out of bounds cause one or both CZEROs to go LOW. Refer to Application Note TP-38 for further information on other boundary violation cases. Each parameter is expressed in 12-bit unsigned binary integer notation. See Figure 12.
UMIN, UMAX, VMIN, VMAX	These four parameters outline the "target" region of the (u, v) plane, into which the resampled image will be written. The IRS will generate, line by line, a scan that fills only this portion of the plane, permitting the user to assemble a mosaic of multiple rectangular subimages. Care must be taken to ensure that UMAX > UMIN and VMAX > VMIN. Each parameter is expressed in 12-bit unsigned binary integer notation. See Figure 12.
(X0, Y0)	These are the coordinates of the first pixel to be read from the original image. In many applications, this point will be one of the four corners of the original image to be resampled. The pixels near (X0, Y0) in the original image will be used to compute the upper left pixel of the transformed image. In non-inverting, non-reversing applications (X0, Y0) will be the upper left corner of the original subimage. Each coordinate is expressed in 13-bit integer plus 5-bit fraction, two's complement notation.

dX/dU_0	Is the initial horizontal partial first derivative indicating the displacement along the X axis which corresponds to each one pixel movement along the U axis. Usually, $0 < dX/dU_0 < 1$ corresponds to magnification, whereas $dX/dU_0 > 1$ represents reduction and $dX/dU_0 < 0$ denotes reflection about a vertical axis. The first derivatives are expressed in 8-bit integer, 12-bit fraction two's complement notation.
dX/dV_0	Is the initial horizontal-vertical partial first derivative. It indicates the displacement along the X axis corresponding to each one pixel movement along the V axis. The coefficients dX/dV_0 and dX/dU_0 define image rotation and shear.
dY/dU_0	Is the initial vertical-horizontal partial first derivative. It indicates the displacement along the Y axis corresponding to each one pixel movement along the U axis.
dY/dV_0	Is the initial vertical partial first derivative. It indicates the displacement along the Y axis corresponding to each one-pixel step along the V axis. Since dX/dV_0 and dY/dV_0 are separate parameters, vertical magnification and reflection need not match their horizontal counterparts.

Note:

- For each incremental move along the U axis, the starting point of the new "walk around spiral" is indexed to the ENDING point of the previous walk around spiral, rather than to its center. Therefore, the terms dX/dU_0 and dY/dU_0 must be adjusted accordingly. Since each new line is referenced back to the previous line's initial spiral starting point, no similar dX/dV_0 or dY/dV_0 correction is needed.

d^2X/dU^2	Is the second order horizontal derivative. It indicates the rate of change of the horizontal-horizontal first derivative with each step along a line in the output image space. All six second-order derivatives are 4-bit integer, 20-bit fractional two's complement parameters.
d^2X/dV^2	Is the second order horizontal-vertical-derivative. It indicates the rate of change of the horizontal-vertical first derivative with each step down a column in the output image space.

d^2Y/dU^2	Is the second order vertical-horizontal-horizontal derivative. It indicates the rate of change of the the vertical-horizontal first derivative with each step along a line of the output image space.								
d^2Y/dV^2	Is the second order vertical derivative. It indicates the rate of change of the vertical-vertical first derivative with each step down a column of the output image space.								
$d^2X/dUdV$	Is the mixed second order derivative indicating the rate of change of the first order horizontal derivative as one proceeds downwards through the output image space. This is also the rate of change of the first order horizontal-vertical derivative during horizontal sweeps in the output image space.								
$d^2Y/dUdV$	Is the mixed second order derivative indicating the rate of change of the first order vertical derivative as one moves horizontally across the output space, or, equivalently, the rate of change of the first order vertical-horizontal derivative as one moves vertically in the output image space								
Row/Column Select	Sets the mode to either Row (0) or Column (1) operation.								
Mode	This 2-bit control word defines three unique instructions: <table border="1" style="margin-left: 20px;"> <thead> <tr> <th>Code</th> <th>Instruction</th> </tr> </thead> <tbody> <tr> <td>00, 01</td> <td>single-pass operation</td> </tr> <tr> <td>10</td> <td>pass 1 of two-pass operation</td> </tr> <tr> <td>11</td> <td>pass 2 of two pass operation</td> </tr> </tbody> </table>	Code	Instruction	00, 01	single-pass operation	10	pass 1 of two-pass operation	11	pass 2 of two pass operation
Code	Instruction								
00, 01	single-pass operation								
10	pass 1 of two-pass operation								
11	pass 2 of two pass operation								

In single-pass operation, the device walks through the entire $(k + 1) \times (k + 1)$ kernel for each output pixel, where k is the value written into the Kernel section (see below) of the parameter register. Two-pass operation, which requires a dimensionally separable kernel, is executed first for a $(k + 1)$ element kernel in one direction, then for a $(k + 1)$ element kernel in the other direction. For kernel sizes exceeding 2×2 , the two-pass algorithm is obviously beneficial, requiring $2n$ samples per output point instead of $n \times n$. In this case, the intermediate image data stored in the destination image memory following the first pass is used as the source image data on the second pass. The user may design a system to

switch source and destination memory bank addresses in place, or could utilize a second TMC2301 pair in a pipelined architecture. This would require a third image buffer for the final destination image. Both devices of a system pair are usually set to the same mode.

Kernel	The effective kernel width (height) exceeds this 4-bit unsigned number by 1, thereby providing kernels of 1×1 to 16×16 source pixels per output, for either resampling or filtering. Simple static filters can be implemented with kernels of up to 16×16 pixels (Kernel = 15), while resampling interpolation kernels are limited to 4×4 pixels (Kernel = 3), due to the four bits of fractional X (or Y) address generated by the TMC2301. See the Applications Discussion. Again, both devices in a pair are generally initialized with equal Kernel values.
Field of View (FOV)	As the device walks through its kernel coefficients, each corresponding step in (x, y) space is normally one pixel length or height; this is a field of view of 1. However, the user can subsample the original space before filtering or resampling, by applying the coefficient kernel over a view field of up to 7 units. At a field of view of F , the pixels selected for each kernel operation are F pixels apart. This is useful in oversampled pictures, whose intensity changes only slowly from pixel to pixel.
Autoload (ALR)	When set to 1 (HIGH), the LDR control is automatically asserted when INIT is strobed, loading the coefficient set currently stored in the preload registers.
Autoinit (AIN)	At the end of an image, if the AIN bit is 1 (HIGH) the DONE flag goes HIGH for one clock cycle and a new transform begins. If 0 (LOW), \overline{UWRI} and the DONE flag remain HIGH during the sequence until the user strobes the INIT control to begin a new image transformation.
Pipe (PIPE)	Adjusts the timing of the target memory write controls, to compensate for buffered source image RAM. If the PIPE bit is 1 (HIGH), outputs \overline{ACC} and \overline{UWRI} will be delayed one clock cycle relative to the generation of the target address (U or V). See Figure 9.

Test Mode (TM)	This mode is available for user inspection of the coefficient data. The source image and coefficient addresses are calculated by an internal 28-bit accumulator. When TM is 1 (HIGH), the sign bit, normally discarded, and the lower 11 bits of internal data are substituted for the upper 12 bits appearing at the source address port (X) during a standard transform cycle. This allows user verification of algorithm mathematics during debug. Since the TM bit is registered and cannot be changed during a single clock cycle, two distinct clock cycles are required to access both the MSW and LSW of the internal accumulator. See Figure 3.
----------------	--

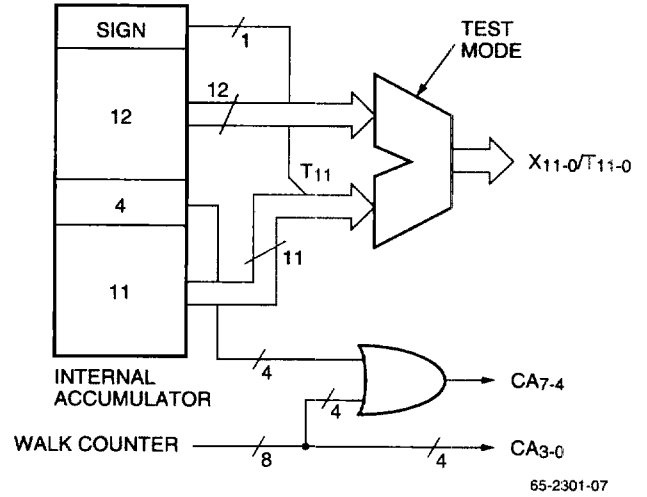

Figure 3. Test Mode Data Routing

Table 1. Parameter Registers – Row Sequencer

Addr	Name	Description
0000	XMIN	Left side of Source Window
0001	XMAX	Right side of Source Window
0010	X ₀ (LSW)	Source starting point – X coordinate
0011	X ₀ (MSW)	Source starting point – X coordinate
0011	Controls	Mode Select Bits
0100	dX/dU ₀ (LSW)	Row/Row first differential
0101	dX/dU ₀ (MSW)	Row/Row first differential
0101	TM, FOV	Test Mode, Field of View
0110	dX/dV ₀ (LSW)	Row/Column first differential
0111	dX/dV ₀ (MSW)	Row/Column first differential
0111	Kernel	Resampling/Filtering Kernel
1000	d ² X/dUdV (LSW)	Mixed second differential
1001	d ² X/dUdV (MSW)	Mixed second differential
1010	d ² X/dU ² (LSW)	Row second differential
1011	d ² X/dU ² (MSW)	Row second differential
1100	d ² X/dV ² (LSW)	Row/Column second differential
1101	d ² X/dV ² (MSW)	Row/Column second differential
1110	UMIN	Left edge of Final Image
1111	UMAX	Right edge of Final Image

Table 2. Parameter Registers – Column Sequencer

Addr	Name	Description
0000	YMIN	Top of Source Window
0001	YMAX	Bottom of Source Window
0010	Y ₀ (LSW)	Source starting point – Y coordinate
0011	Y ₀ (MSW)	Source starting point – Y coordinate
0011	Controls	Mode Select Bits
0100	dY/dU ₀ (LSW)	Column/Row first differential
0101	dY/dU ₀ (MSW)	Column/Row first differential
0101	TM, FOV	Test Mode, field of View
0110	dY/dV ₀ (LSW)	Column/Column first differential
0111	dY/dV ₀ (MSW)	Column/Column first differential
0111	Kernel	Resampling/Filtering Kernel Sure
1000	d ² Y/dUdV (LSW)	Mixed second differential
1001	d ² Y/dUdV (MSW)	Mixed second differential
1010	d ² Y/dU ² (LSW)	Column/Row second differential
1011	d ² Y/dU ² (MSW)	Column/Row second differential
1100	d ² Y/dV ² (LSW)	Column second differential
1101	d ² Y/dV ² (MSW)	Column second differential
1110	VMIN	Top edge of Final Image
1111	VMAX	Bottom edge of Final Image

Table 3. Parameter Registers Binary Format (Row or Column Sequencer)

Address	Format												Limits	
	MSB						LSB						Dec	Hex
0000*	2^{11}	2^{10}	2^9	2^8	2^7	2^6	2^5	2^4	2^3	2^2	2^1	2^0	4095 0	FFF 000
0001*	2^{11}	2^{10}	2^9	2^8	2^7	2^6	2^5	2^4	2^3	2^2	2^1	2^0	4095 0	FFF 000
0010	2^6	2^5	2^4	2^3	2^2	2^1	2^0	2^{-1}	2^{-2}	2^{-3}	2^{-4}	2^{-5}	4096- 2^5 -4096	0FFF.F8 F000.00
0011							-2^{12}	2^{11}	2^{10}	2^9	2^8	2^7		
0011 (Control)	ALR	AIN	PIPE	R/C	M ₁	M ₀								
0100	2^{-1}	2^{-2}	2^{-3}	2^{-4}	2^{-5}	2^{-6}	2^{-7}	2^{-8}	2^{-9}	2^{-10}	2^{-11}	2^{-12}	128- 2^{-12} -128	007F.FFF FF80.000
0101					-2^7	2^6	2^5	2^4	2^3	2^2	2^1	2^0		
0101* (TM, FOV)	TM	2^2	2^1	2^0										
0110	2^{-1}	2^{-2}	2^{-3}	2^{-4}	2^{-5}	2^{-6}	2^{-7}	2^{-8}	2^{-9}	2^{-10}	2^{-11}	2^{-12}	128- 2^{-12} -128	007F.FFF FF80.000
0111					-2^7	2^6	2^5	2^4	2^3	2^2	2^1	2^0		
0111* (Kernel)	2^3	2^2	2^1	2^0									15 0	f 0
1000	2^{-9}	2^{-10}	2^{-11}	2^{-12}	2^{-13}	2^{-14}	2^{-15}	2^{-16}	2^{-17}	2^{-18}	2^{-19}	2^{-10}	8- 2^{-20} -8	0007.FFFFF
1001	-2^3	2^2	2^1	2^0	2^{-1}	2^{-2}	2^{-3}	2^{-4}	2^{-5}	2^{-6}	2^{-7}	2^{-8}		
1010	2^{-9}	2^{-10}	2^{-11}	2^{-12}	2^{-13}	2^{-14}	2^{-15}	2^{-16}	2^{-17}	2^{-18}	2^{-19}	2^{-10}	8- 2^{-20} -8	0007.FFFFF
1011	-2^3	2^2	2^1	2^0	2^{-1}	2^{-2}	2^{-3}	2^{-4}	2^{-5}	2^{-6}	2^{-7}	2^{-8}		
1100	2^{-9}	2^{-10}	2^{-11}	2^{-12}	2^{-13}	2^{-14}	2^{-15}	2^{-16}	2^{-17}	2^{-18}	2^{-19}	2^{-10}	8- 2^{-20} -8	0007.FFFFF
1101	-2^3	2^2	2^1	2^0	2^{-1}	2^{-2}	2^{-3}	2^{-4}	2^{-5}	2^{-6}	2^{-7}	2^{-8}		
1110*	2^{11}	2^{10}	2^9	2^8	2^7	2^6	2^5	2^4	2^3	2^2	2^1	2^0	4095 0	FF 000
1111*	2^{11}	2^{10}	2^9	2^8	2^7	2^6	2^5	2^4	2^3	2^2	2^1	2^0	4095 0	FF 000

Notes:

- * unsigned binary notation
- A "-" indicates MSB is sign bit

Internal Bit Mapping (For parametric inputs, integers in table are bits of P, the input point)

	2 ¹²	2 ¹¹	2 ¹⁰	2 ⁹	2 ⁸	2 ⁷	2 ⁶	2 ⁵	2 ⁴	2 ³	2 ²	2 ¹	2 ⁰	2 ⁻¹	2 ⁻²	2 ⁻³	2 ⁻⁴
XOUT [11:0]		11	10	9	8	7	6	5	4	3	2	1	0				
CADN [7:4]														7	6	5	4
XMAX, XMIN		11	10	9	8	7	6	5	4	3	2	1	0				
XO	5	4	3	2	1	0	11	10	9	8	7	6	5	4	3	2	1
DX/DU, DX/DV						7	6	5	4	3	2	1	0	11	10	9	8
D ² X/DUDV, D ² X/DU ² , D ² X/DV ²										11	10	9	8	7	6	5	4

	2 ⁻⁵	2 ⁻⁶	2 ⁻⁷	2 ⁻⁸	2 ⁻⁹	2 ⁻¹⁰	2 ⁻¹¹	2 ⁻¹²	2 ⁻¹³	2 ⁻¹⁴	2 ⁻¹⁵	2 ⁻¹⁶	2 ⁻¹⁷	2 ⁻¹⁸	2 ⁻¹⁹	2 ⁻²⁰
XOUT [11:0]																
CADN [7:4]																
XMAX, XMIN																
XO	0															
DX/DU, DX/DV	7	6	5	4	3	2	1	0								
D ² X/DUDV, D ² X/DU ² , D ² X/DV ²	3	2	1	0	11	10	9	8	7	6	5	4	3	2	1	0

Operation of the Transformation Parameter Registers

Numerous applications require the ability to update the coordinate transformation parameters "on the fly." Because the parameters are double-buffered, the user can load any or all of them into the preload registers without upsetting the operation in progress. Then LDR (load data registers) will update all transform parameters to the new values simultaneously. This feature is particularly valuable for "pin cushion" and "fish eye" transformations, or polar-to-rectangular conversions which cannot be performed with constant second derivatives. The Autoload function updates the preread registers at the beginning of a new image automatically. See the Transformation Control Parameters section. Note also that data can be loaded in to the registers while NOOP is active (LOW).

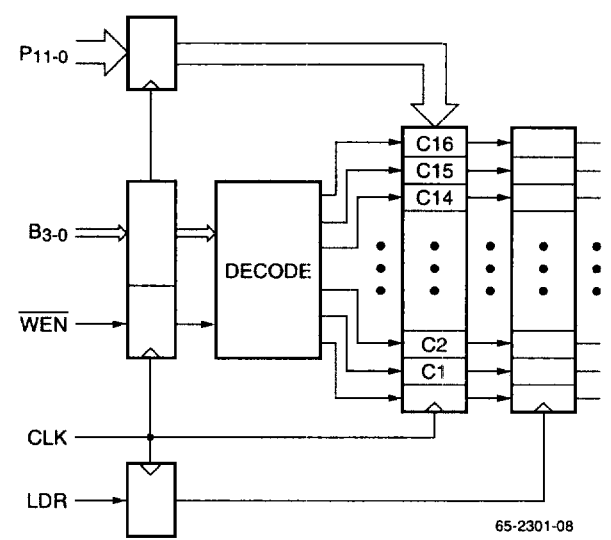
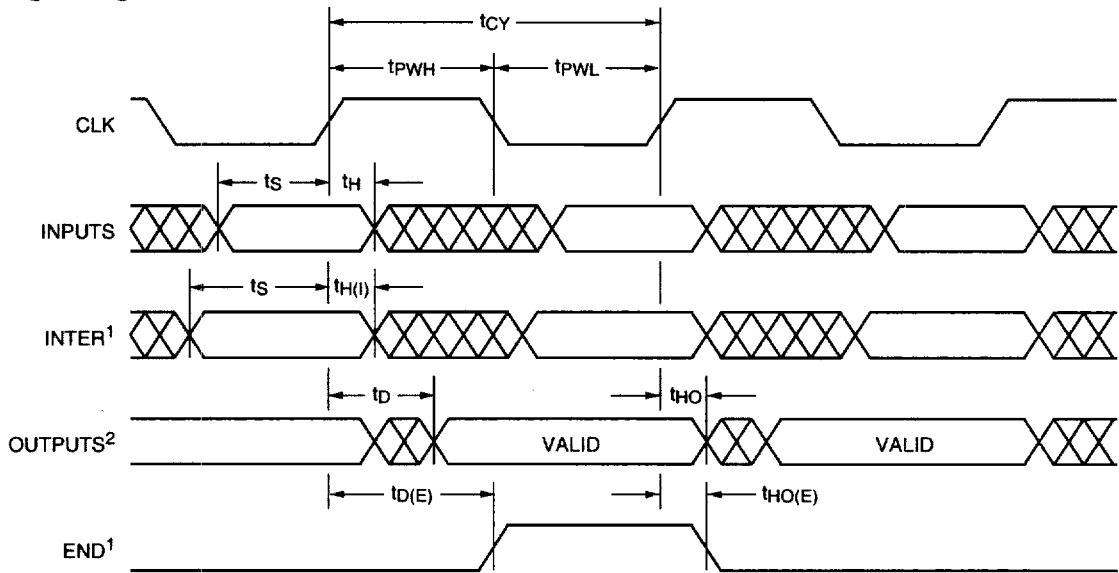

Figure 4. Operation of LDR Control for Parameter Update

Timing Diagram



65-2301-09

Notes:

1. t_s and $t_{D(E)}$ are guaranteed to allow full speed operation in the standard two-device architecture. See text.
2. All outputs except END. See text.

Equivalent Circuits and Transition Levels

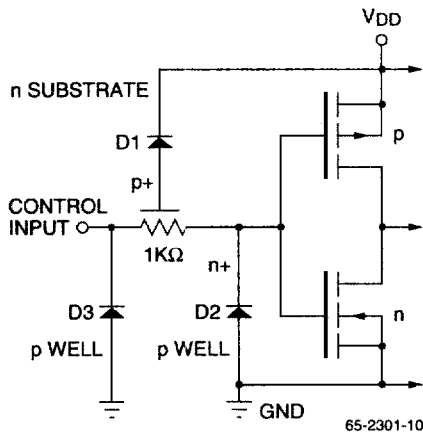

65-2301-10

Figure 5. Equivalent Input Circuit

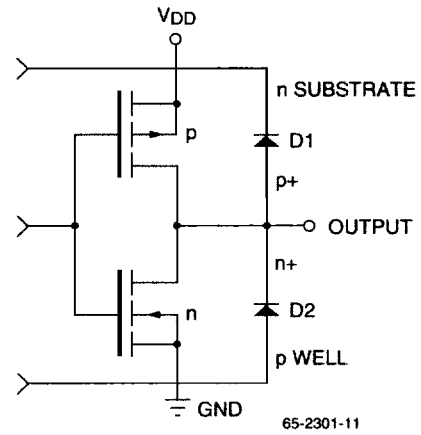

65-2301-11

Figure 6. Equivalent Output Circuit

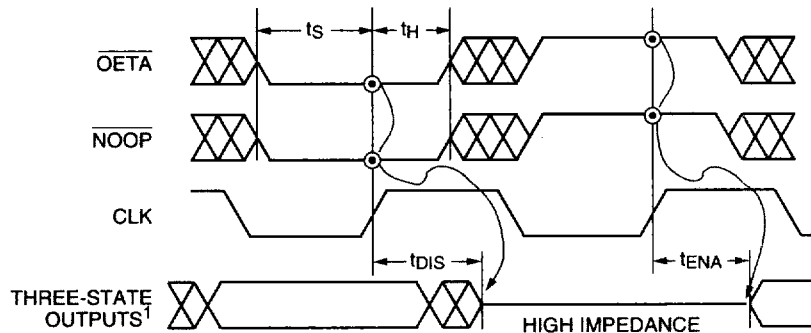

65-2301-12

Note:

1. All outputs except \overline{CZERO} , \overline{ACC} , END and DONE.

Figure 7. Transition Level for Three-State Output

Absolute Maximum Ratings (beyond which the device may be damaged)¹

Parameter	Min	Typ	Max	Unit
Supply Voltage	-0.5		7.0	V
Input Voltage	-0.5		VDD + 0.5	V
Output				
Applied Voltage ²	-0.5		VDD + 0.5	V
Forced Current ^{3,4}	-1.0		6.0	mA
Short Circuit Duration (single output in HIGH state to ground)			1	sec
Temperature				
Operating, Case	-60		130	°C
Operating, Junction			175	°C
Lead Soldering (10 seconds)			300	°C
Storage	-65		150	°C

Notes:

1. Absolute maximum ratings are limiting values applied individually while all other parameters are within specified operating conditions. Functional operation under any of these conditions is NOT implied.
2. Applied voltage must be current limited to specified range, and measured with respect to GND.
3. Forcing voltage must be limited to specified range.
4. Current is specified as conventional current flowing into the device.

Operating Conditions

Parameter		Temperature Range						Units
		Standard			Extended			
		Min	Typ	Max	Min	Typ	Max	
VDD	Supply Voltage	4.75	5.0	5.25	4.5	5.0	5.5	V
VIL	Input Voltage, Logic LOW			0.8			0.8	V
VIH	Input Voltage, Logic HIGH	2.0			2.0			V
IOL	Output Current, Logic LOW			8.0			8.0	mA
IOH	Output Current, Logic HIGH			-4.0			-4.0	mA
TA	Ambient Temperature, Still Air	0		70				°C
TC	Case Temperature				-55		125	°C

DC Characteristics within specified operating conditions¹

Parameter		Conditions	Temperature Range				Units
			Standard		Extended		
			Min	Max	Min	Max	
IDDQ	Supply Current, Quiescent	VDD = Max, VIN = 0V		5		5	mA
IDDU	Supply Current, Unloaded	VDD = Max, f = 15MHz		75		75	mA
IIL	Input Current, Logic LOW	VDD = Max, VIN = 0V	-10	10	-75	75	μA
IiH	Input Current, Logic HIGH	VDD = Min, VIN = VDD	-10	10	-75	75	μA
VOL	Output Voltage, Logic LOW	VDD = Min, IOL = Max		0.4		0.4	V
VOH	Output Voltage, Logic HIGH	VDD = Min, IOH = Max	2.4		2.4		V
IOZL	Hi-Z Output Leakage Current, Output LOW	VDD = Min, VIN = 0V	-40	40	-40	40	μA
IOZH	Hi-Z Output Leakage Current, Output HIGH	VDD = Min, VIN = VDD	-40	40	-40	40	μA
IOS	Short-Circuit Output Current ²	VDD = Max, Output HIGH, one pin to ground, one second duration max.		-100		-100	mA
CI	Input Capacitance	TA = 25°C, f = 1MHz		10		10	pF
CO	Output Capacitance	TA = 25°C, f = 1MHz		10		10	pF

Notes:

1. Actual test conditions may vary from those shown, but guarantee operation as specified.
2. Guaranteed but not tested.

AC Characteristics within specified operating conditions

Parameter		Conditions	Temperature Range								Unit
			Standard				Extended				
			-2		-1						
			Min	Max	Min	Max	Min	Max	Min	Max	
tCY	Cycle Time	VDD = Min	50		55		66		66		ns
tpWL	Clock Pulse Width LOW	VDD = Min	20		22		25		30		ns
tpWH	Clock Pulse Width HIGH	VDD = Min	25		28		33		35		ns
tS	Input Setup Time ¹		15		18		20		20		ns
tH	Input Hold Time		1		2		2		2		ns
tH(I)	Input Hold Time, INTER		8		10		10		10		ns
tD	Output Delay ²	VDD = Min, CLOAD = 40pF		25		27		35		35	ns
tD(E)	Output Delay, END ¹	VDD = Min, CLOAD = 10pF		35		37		45		45	ns
tHO	Output Hold Time ²	VDD = Max, CLOAD = 40pF	5		5		5		5		ns
tHO(E)	Output Hold Time, END	VDD = Max, CLOAD = 10pF	10		10		10		10		ns
tDIS	Three-State Disable Delay	VDD = Min, CLOAD = 40pF		25		27		35		35	ns
tENA	Three-State Enable Delay	VDD = Min, CLOAD = 40pF	25		27		35		35		ns

Notes:

1. tS + tD(E) = tCY max.
2. Excluding output pin END.

Table 4. IRS Outputs for Static Filter Illustrated in Figure 10

Cycle	X	Y	Index (CA)	Coefficient	U	V
1	3	4	0	0.2176	2	4
2	4	4	1	0.0725	2	4
3	4	5	2	0.0435	2	4
4	3	5	3	0.0725	2	4
5	2	5	4	0.0435	2	4
6	2	4	5	0.0725	2	4
7	2	3	6	0.0435	2	4
3	3	3	7	0.0725	2	4
9	4	3	8	0.0435	2	4
10	5	3	9	0.0198	2	4
11	5	4	10	0.0272	2	4
12	5	5	11	0.0198	2	4
13	5	6	12	0.0128	2	4
14	4	6	13	0.0198	2	4
15	3	6	14	0.0272	2	4
16	2	6	15	0.0198	2	4
17	1	6	16	0.0128	2	4
18	1	5	17	0.0198	2	4
19	1	4	18	0.0272	2	4
20	1	3	19	0.0198	2	4
21	2	2	20	0.0128	2	4
22	3	2	21	0.0198	2	4
23	4	2	22	0.0272	2	4
24	5	2	23	0.0198	2	4
25	4	2	24	0.0128	2	4
26		4	0	0.2175	3	4

However, we have included a linear compression factor of 5:1, and must accommodate the fact that each time u is incremented, the start of the new walk is referenced to the END of the previous walk. Given these corrections, the rotation matrix becomes:

$$\begin{aligned}
 dX/dU_0 &= 5\cos(a) = 3 & dY/dU_0 &= 5\sin(a) - FOV = 3 \\
 dX/dV_0 &= 5\sin(a) = -4 & dY/dV_0 &= 5\cos(a) = 3 \\
 \text{Kernel} &= 1
 \end{aligned}$$

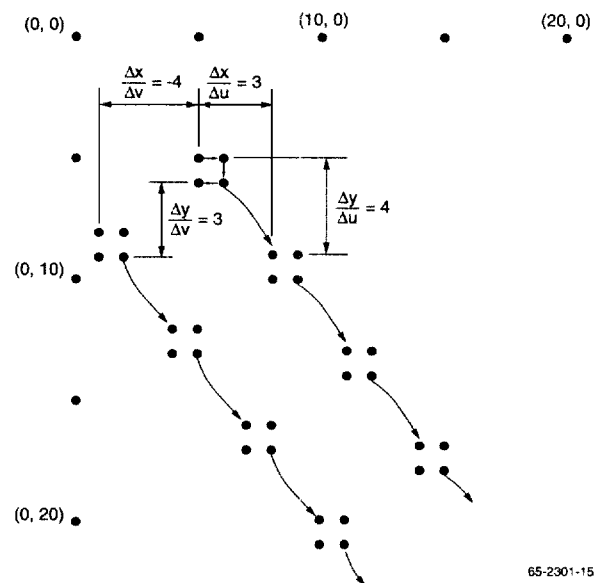

Figure 10. Pixel Map Showing parameters for 63° Rotation and 5:1 Compression Listed in Table 5

Figure 10 illustrates the sequence for a bilinear resampling of a 63° rotation. The starting point is translated +1 in the Y-direction. A common rotation matrix might be:

$$\begin{aligned}
 dX/dU_0 &= \cos(a) = .6 & dY/dU_0 &= \sin(a) = .8 \\
 dX/dV_0 &= -\sin(a) = -.8 & dY/dV_0 &= \cos(a) = .6
 \end{aligned}$$

Table 5. IRS Outputs for Operation Illustrated in Figure 11

Cycle	X	Y	Index	U	V
1	5	5	0	4	5
2	6	5	1	4	5
3	6	6	2	4	5
4	5	6	3	4	5
5	8	9	0	5	5
6	9	9	1	5	5
7	9	10	2	5	5
8	8	10	3	5	5
9	11	13	0	6	5
10	12	13	1	6	5
11	12	14	2	6	5
12	11	14	3	6	5
13	14	17	0	7	5
14	15	17	1	7	5
15	15	18	2	7	5
16	14	18	3	7	5
17	1	8	0	8	5
18	2	8	1	8	5
19	2	9	2	8	5
20	1	9	3	8	5
21	4	12	0	5	6
22	5	12	1	5	6
23	5	13	2	5	6
24	4	13	3	5	6
25	7	16	0	6	6
26	8	16	1	6	6
27	8	17	2	6	6
28	7	17	3	6	6
29	10	20	0	7	6
30	11	20	1	7	6
31	11	21	2	7	6
32	10	21	3	7	6
33	0	5	0	8	6

Figure 11 may help clarify the relationships among (X_0, Y_0) , (X_{MIN}, Y_{MIN}) , (X_{MAX}, Y_{MAX}) , (U_{MIN}, V_{MIN}) , and (U_{MAX}, V_{MAX}) . With positive first derivatives, (X_0, Y_0) and (U_{MIN}, V_{MIN}) represent the upper left corners of the original image and the new destination field, respectively. The lower right corner of the transformed image is located at

$(U_{MAX} + 1, V_{MAX} + 1)$; the location of the corresponding corner of the original image depends on the values of the derivatives. Not to be confused with (X_0, Y_0) , the points (X_{MIN}, Y_{MIN}) and (X_{MAX}, Y_{MAX}) define the "usable" rectangular portion of the original image; points (X, Y) lying outside this region are ignored in most resampling and filtering applications. This feature permits one to construct a mosaic of several abutting subimages in the (x, y) plane, without danger of edge effect interference between adjacent subimages. Note in the figure that the upper right and lower right corners of the resampled image lie outside the admissible region; in practice, the values fetched at these locations will not be included in the convolutional sums.

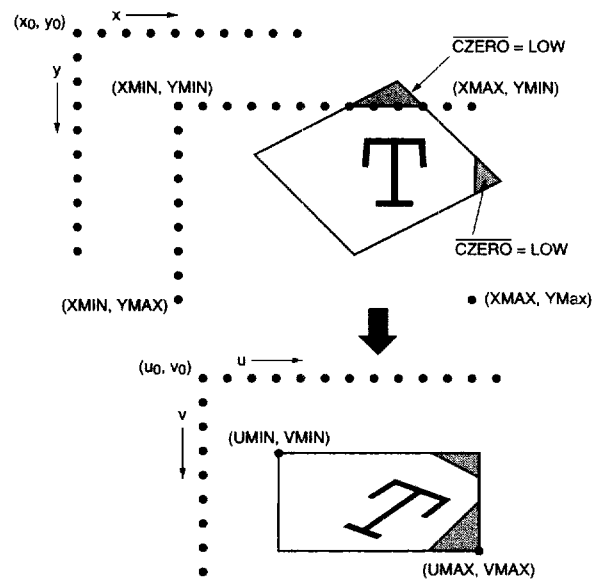

Note: Assume $000h < X < FFFh$, $000h < Y < FFFh$ 65-2301-15

Figure 11. Pixel Maps Demonstrating Source and Destination Image Boundaries and Image Clipping (Note Shaded Area)

Application Note

Nearest Neighbor Operation—Additional Timing Details

Example A, PIPE = 0

Inspecting Figure 13:

PIPE = 0, KER = 0 (near neighbor), AUTOIN = 1 (on),

UMN = 0, UMX = 5, VMN = 0, VMX = 5,

DX/DU = 1, DY/DV = 1, XO = 0

First rising edge of CLK after INIT falling edge is #0.

Table entries are events after listed clock rising edge.

END, DONE flags = 0, except where shown as 1.

UWRI goes low and remains low with CLK #2.

CLK	X	U	V	END		DON	Comments
				R	C		
0				0	0		First clock after INIT falling edge
1				0	0		
2	0			0	0		First valid X addresses = XO
3	1	0	0	0	0		Second X; first valid U, V = UMN, VMN
4	2	1	0	0	0		
5	3	2	0	1	0		END ROW flag 3 cycles before last X
6	4	3	0	0	0		
7	5	4	0	0	0		
8	6	5	0	0	0		Last X of first row
9	0	6	0	0	0		Last U, V or first row; first X of 2nd row
10	1	0	1	0	0		First U, V of second row
11	2	1	1	0	0		
12	3	2	1	1	0		END ROW flag 4 cycles before last U, V
13	4	3	1	0	0		
14	5	4	1	0	0		
15	6	5	1	0	0		Last X of second row
16	0	6	1	0	0		Last U, V of second row U = UMX + 1
35	5	4	4	0	1		END COL goes high before last X
36	6	5	4	0	1		Last X of V = VMX - 1 row
37	0	6	4	0	1		First X of Last (V = VMX) row
38	1	0	5	0	1		First U, V = UMN, VMX of last row
39	2	1	5	0	1		
40	3	2	5	1	1		Last END ROW flag of frame
41	4	3	5	0	1		END COL goes low when DONE goes high
42	5	4	5	0	0	1	DONE immediately before last X
43	6	5	5	0	0		Last X of frame
44	0	6	5	0	0		Last U, V = UMX + 1, VMX
45	1	0	0	0	0		First U, V = UMN, VMN of new frame
46	2	1	0	0	0		
47	3	2	0	1	0		First END ROW flag of new frame

Example B, PIPE = 1

Now, referring to Figure 14:

PIPE = 1, KER = 0 (near neighbor), AUTOIN = 1 (on),

UMN = 0, UMX = 5, VMN = 0, VMX = 5,

DX/DU = 1, DY/DV = 1, XO = 0

First rising edge of CLK after INIT falling edge is #0.

Table entries are events after listed clock rising edges.

END, DONE, flags = 0, except where shown as 1.

UWRI goes low with CLK #3, stays low. Otherwise, the timing is the same as Figure 13, i.e., pipeline delays UWRI and ACC by one clock cycle.

Bilinear Interpolation

Example C, PIPE = 0

From Figure 15, we can see the following:

PIPE = 0, KER = 1 (bilinear), AUTOIN = 1 (on),

UMN = 0, UMX = 5, VMN = 0, VMX = 5,

DX/DU = 1, DY/DV = 1, YO = 0, XO = 0

First rising edge of CLK after INIT falling edge is #0.

Table entries are events after listed clock rising edges.

END, DONE flags = 0, except where shown as 1.

CLK	X	U	V	END ROW	UWR	ACC	DON	Comments
0					1	0		1st CLK after INIT falling edge
1					0	0		
2	0				1	0		1st valid X address = XO: start 1st ACCum
3	1				0	1		
4	1				1	1		
5	0				1	1		End 1st 2x2 kernel; end 1st ACCum
6	1	0	0		1	0		1st valid u, v = UMN, VMN; 2nd ACCum start
7	2	0	0		0	1		
8	2	0	0		1	1		
9	1	0	0		1	1		
10	2	1	0		1	0		2nd valid u, v = UMN + 1, VMN
11	3	1	0		0	1		
12	3	1	0		1	1		
13	2	1	0		1	1		
14	3	2	0		1	0		3rd valid u, v = UMN + 2, VMN
15	4	2	0		0	1		
16	4	2	0		1	1		
17	3	2	0		1	1		End 4th 2x2 kernel
160	5	3	5	1	1	1		
161	4	3	5	1	1	1		
162	5	4	5	1	1	0		Begin next-to-last x-walk
163	6	5	4	1	0	1		
164	6	5	4		1	1		

CLK	X	U	V	END ROW	UWR	ACC	DON	Comments
165	5	4	5		1	1		
166	6	5	5		1	0		Begin last x-walk
167	7	5	5		0	1		
168	7	5	5		1	1	1	
169	6	5	5		1	1		Last x of frame
170	0	6	5		1	0		
171	1	6	5		0	1		
172	1	6	5		1	1		
173	0	6	5		1	1		Last u, v = UMX + 1, VMX
174	1	0	0		1	0		First u, v of new frame
175	2	0	0		0	1		
176	2	0	0		1	1		
177	1	0	0		1	1		

Example D, KER = 0 (nearest neighbor), UMIN = 0, UMAX = 3, UMIN = 0, VMAX = 2

If first CLOCK edge after INIT goes low is 0, then:
 First x, y out (= XO, YO) appears after CLOCK edge 2.
 First u, v out (= 0, 0) appears after CLOCK edge 3.
 END is high after CLOCK edge 13 only.
 DONE is high after CLOCK edge 16.
 Last x out appears after CLOCK edge 16.
 Last u, v out (= 4, 2) appears after CLOCK edge 17.

Example E, KER = 1, (1 pass bilinear), UMIN = 0, UMAX = 4, VMIN = 1, VMAX = 3

If first CLOCK edge after INIT goes low is 0, then:
 First x, y out (= XO, YO) appears after CLOCK edge 2.
 First u, v out (= 0, 1) appears after CLOCK edge 6 and remains through edges 7, 8 and 9.
 END is high after CLOCK edge 92, goes low after 96.
 DONE is high after CLOCK edge 100 only.
 Last x out appears CLOCK edge 101.
 Last u, v out (= 5, 3) appears after CLOCK edge 102 and remains through edges 103, 104 and 105.

Performing Larger Interpolation Kernels

With PIPE = 0, AUTOINIT = 1, and the following definitions:

T_{xdone} = Clock cycle of final X address of a transform.

T_{xend} = Clock cycle of final X address along a row.

$KER = (K + 1)(K + 1)$, where K is the value in the "kernel size" parameter register.

The following relationships hold true:

First X address valid 3 rising clock edges after INIT's falling edge.

END FLAG goes HIGH for KER cycles at clock cycle $T_{xend} - 1 - 2 * KER$. Otherwise stated, END is active for one walkaround starting two walkarounds and one cycle prior to the final source address of a row.

DONE FLAG goes HIGH for one cycle at clock cycle $T_{xdone} - 1$. Otherwise stated, DONE is active for one clock cycle one cycle prior to the last source address of the final walkaround.

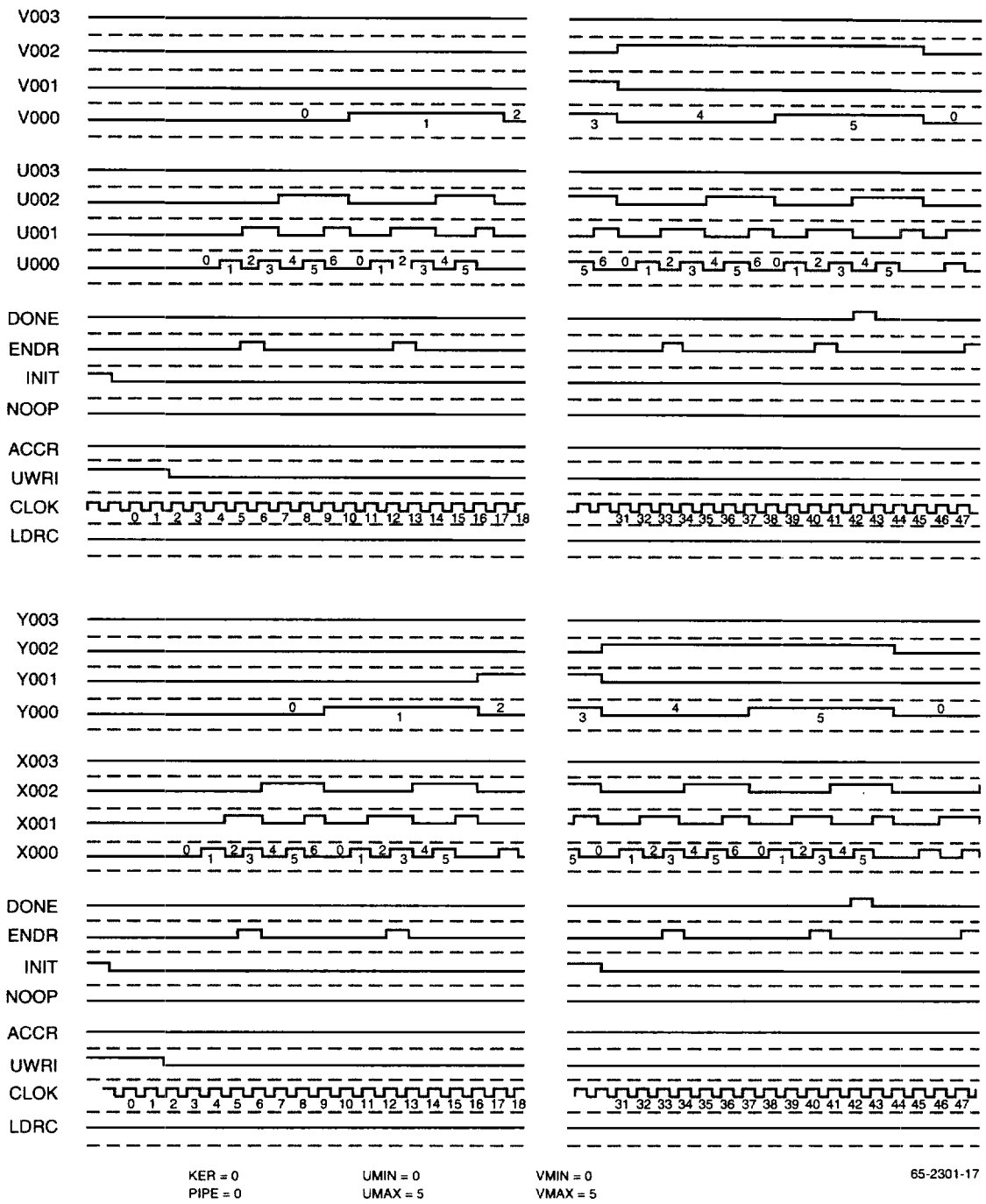
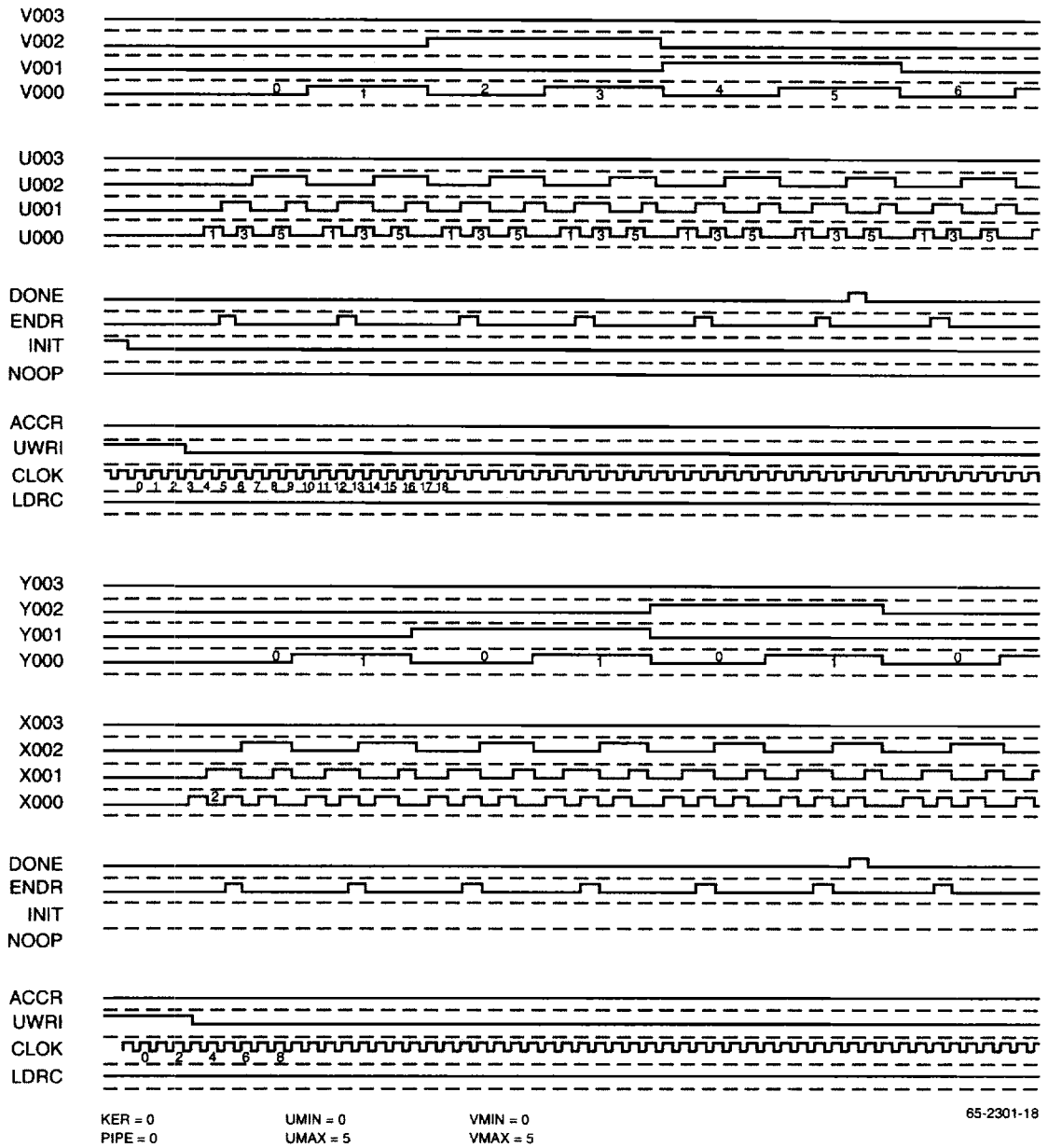

Figure 12.



65-2301-18

Figure 13.

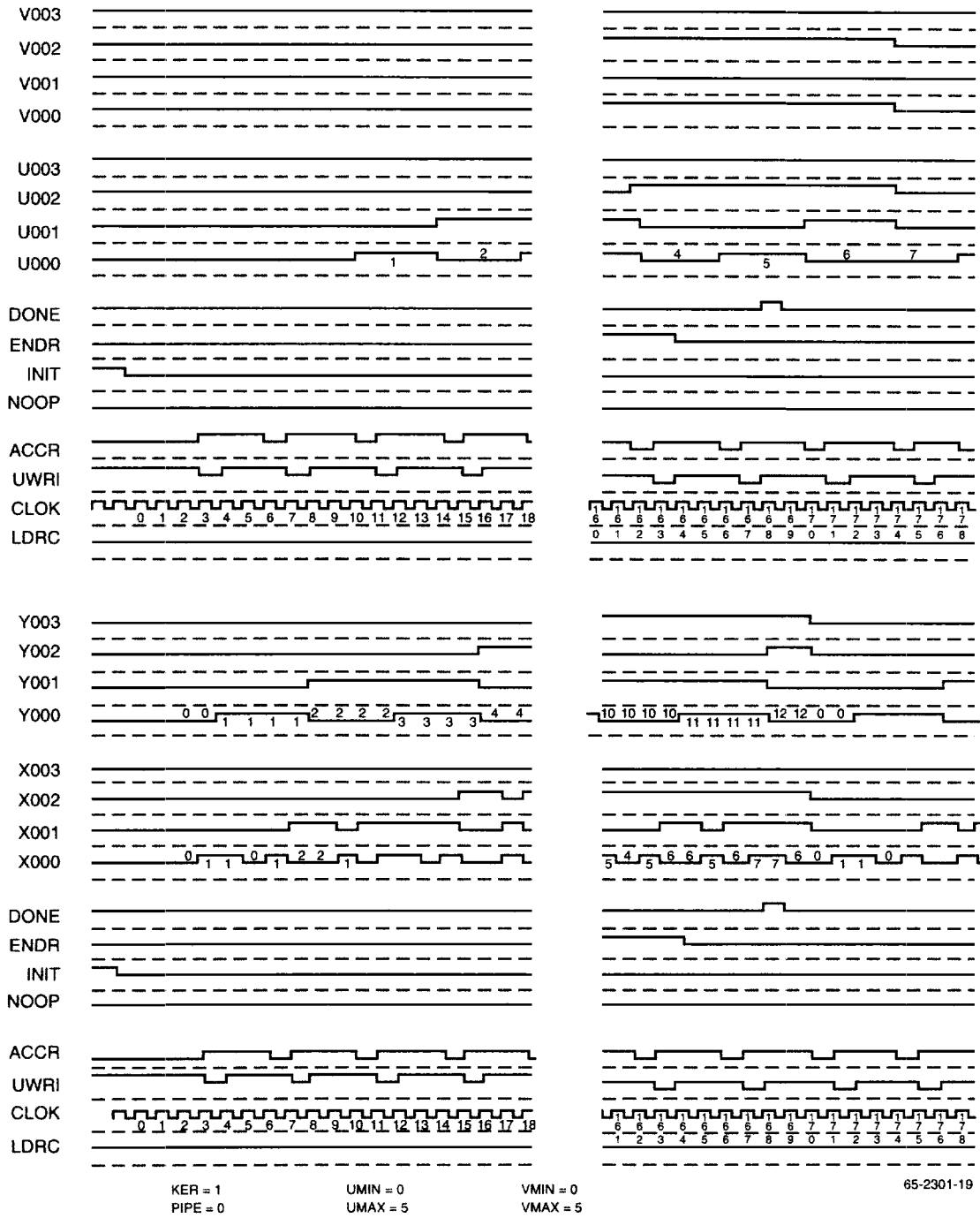

Figure 14

Notes:

Notes:

Mechanical Dimensions

68 Lead Pin Grid Array

Symbol	Inches		Millimeters		Notes
	Min.	Max.	Min.	Max.	
A	.080	.125	2.03	3.18	
A1	.040	.060	1.02	1.52	
A2	.115	.190	2.92	4.83	
øB	.017	.020	0.43	0.51	
øB2	.050 NOM.		1.27 NOM.		
D	1.140	1.180	28.96	29.97	
D1	1.000 BSC		25.40 BSC		
e	.100 BSC		2.54 BSC		
L	.120	.140	3.05	3.56	
M	11		11		2
N	68		68		3
P	.003	—	.076	—	

Notes:

1. Pin #1 identifier shall be within shaded area shown.
2. Dimension "M" defines matrix size.
3. Dimension "N" defines the maximum possible number of pins.
4. Controlling dimension: inch.
5. Optional index pin.

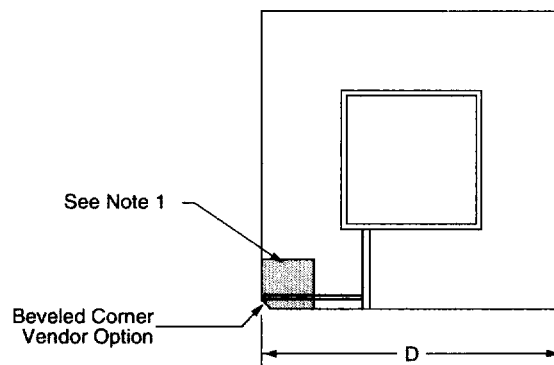
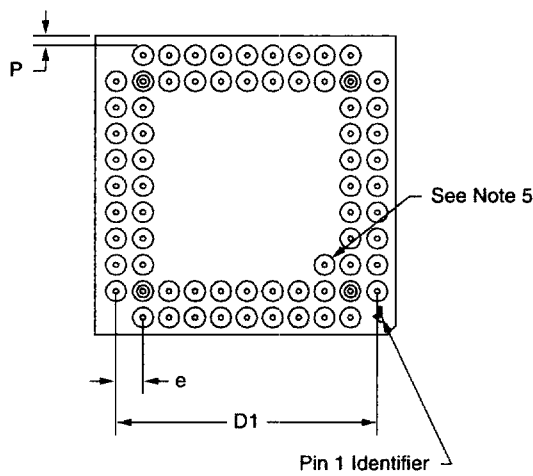
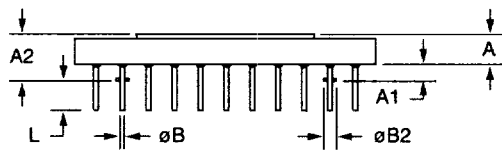

Mechanical Dimensions (continued)

68 Lead Plastic Leaded Chip Carrier

Symbol	Inches		Millimeters		Notes
	Min.	Max.	Min.	Max.	
A	.165	.200	4.19	5.08	
A1	.090	.130	2.29	3.30	
A2	.020	—	.51	—	
B	.013	.021	.33	.53	
B1	.026	.032	.66	.81	
D/E	.985	.995	25.02	25.27	
D1/E1	.950	.958	24.13	24.33	3
D3/E3	.800 BSC		20.32 BSC		
e	.050 BSC		1.27 BSC		
J	.042	.056	1.07	1.42	2
ND/NE	17		17		
N	68		68		
ccc	—	.004	—	0.10	

Notes:

1. All dimensions and tolerances conform to ANSI Y14.5M-1982
2. Corner and edge chamfer (J) = 45°
3. Dimension D1 and E1 do not include mold protrusion. Allowable protrusion is .101" (.25mm)

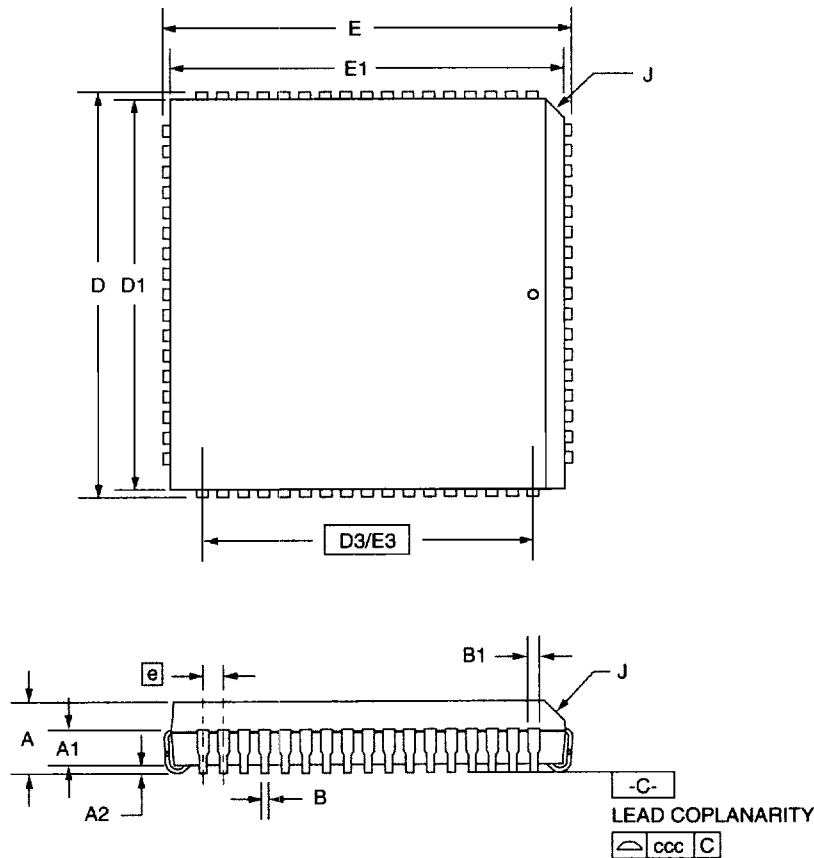

Ordering Information

Product Number	Temperature Range	Screening	Package	Package Marking
TMC2301G8C	STD-T _A = 0°C to 70°C	Commercial	68 Pin Grid Array	2301G8C
TMC2301G8C1	STD-T _A = 0°C to 70°C	Commercial	68 Pin Grid Array	2301G8C1
TMC2301G8C2	STD-T _A = 0°C to 70°C	Commercial	68 Pin Grid Array	2301G8C2
TMC2301G8A	EXT-T _C = -55°C to 125°C	Hi Rel	68 Pin Grid Array	2301G8A
TMC2301G8A1	EXT-T _C = -55°C to 125°C	Hi Rel	68 Pin Grid Array	2301G8A1
TMC2301H8C	STD-T _A = 0°C to 70°C	Commercial	68 Pin Grid Array	2301H8C
TMC2301H8C1	STD-T _A = 0°C to 70°C	Commercial	68 Pin Grid Array	2301H8C1
TMC2301H8C2	STD-T _A = 0°C to 70°C	Commercial	68 Pin Grid Array	2301H8C2
TMC2301L1A	EXT-T _C = -55°C to 125°C	Hi Rel	68 Leaded Hermetic Ceramic Chip Carrier	2301L1A
TMC2301L1A1	EXT-T _C = -55°C to 125°C	Hi Rel	68 Leaded Hermetic Ceramic Chip Carrier	2301L1A1
TMC2301R1C	STD-T _A = 0°C to 70°C	Commercial	68 Lead Plastic J-Leaded Chip Carrier	2301R1C
TMC2301R1C1	STD-T _A = 0°C to 70°C	Commercial	68 Lead Plastic J-Leaded Chip Carrier	2301R1C1
TMC2301R1C2	STD-T _A = 0°C to 70°C	Commercial	68 Lead Plastic J-Leaded Chip Carrier	2301R1C2

The information contained in this data sheet has been carefully compiled; however, it shall not by implication or otherwise become part of the terms and conditions of any subsequent sale. Raytheon's liability shall be determined solely by its standard terms and conditions of sale. No representation as to application or use or that the circuits are either licensed or free from patent infringement is intended or implied. Raytheon reserves the right to change the circuitry and any other data at any time without notice and assumes no liability for errors.

LIFE SUPPORT POLICY:

Raytheon's products are not designed for use in life support applications, wherein a failure or malfunction of the component can reasonably be expected to result in personal injury. The user of Raytheon components in life support applications assumes all risk of such use and indemnifies Raytheon Company against all damages.

Raytheon Electronics
Semiconductor Division
5580 Morehouse Drive
San Diego, CA 92121
619 457 1000
800 722 7074
Fax 619 455 6314
applications@lj.sd.ray.com