

General Description

The MIC5800/5801 latched drivers are high-voltage, high-current integrated circuits comprised of four or eight CMOS data latches, a bipolar Darlington transistor driver for each latch, and CMOS control circuitry for the common CLEAR, STROBE, and OUTPUT ENABLE functions.

The bipolar/MOS combination provides an extremely low-power latch with maximum interface flexibility. MIC5800 contains four latched drivers; MIC5801 contains eight latched drivers.

Data input rates are greatly improved in these devices. With a 5V supply, they will typically operate at better than 5MHz. With a 12V supply, significantly higher speeds are obtained.

The CMOS inputs are compatible with standard CMOS, PMOS, and NMOS circuits. TTL or DTL circuits may require the use of appropriate pull-up resistors. The bipolar outputs are suitable for use with relays, solenoids, stepping motors, LED or incandescent displays, and other high-power loads.

Both units have open-collector outputs and integral diodes for inductive load transient suppression. The output transistors are capable of sinking 500mA and will sustain at least 50V in the OFF state. Because of limitations on package power dissipation, the simultaneous operation of all drivers at maximum rated current can only be accomplished by a reduction in duty cycle. Outputs may be paralleled for higher load current capability.

Features

- 4.4MHz Minimum Data Input Rate
- High-Voltage, Current Sink Outputs
- Output Transient Protection
- CMOS, PMOS, NMOS, and TTL Compatible Inputs
- Internal Pull-Down Resistors
- Low-Power CMOS Latches

Ordering Information

Part Number	Temperature Range	Package
MIC5800BN	- 40°C to + 85°C	14-Pin Plastic DIP
MIC5800AJ	- 55°C to +125°C	14-Pin Cerdip
5962-8764002CA ¹	- 55°C to +125°C	14-Pin Cerdip
MIC5800BM	- 40°C to + 85°C	14-Pin SOIC
MIC5801BN	- 40°C to +85°C	22-Pin Plastic DIP
MIC5801AJ	- 55°C to +125°C	22-Pin Cerdip
5962-8764001WA ²	- 55°C to +125°C	22-Pin Cerdip
MIC5801BV	- 40°C to + 85°C	28-Pin PLCC
MIC5801BWM	- 40°C to +85°C	24-Pin SOIC

¹ Standard Military Drawing number for MIC5800AJBQ

² Standard Military Drawing number for MIC5801AJBQ

Functional Diagram

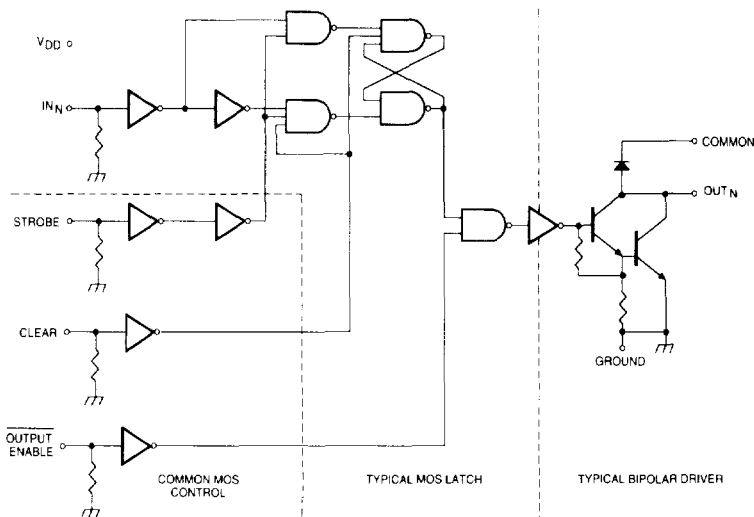

Typical Input

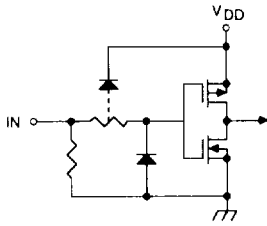

Absolute Maximum Ratings: (Notes 1-7)

at +25°C Free-Air Temperature

Output Voltage, V_{CE}	50V
Supply Voltage, V_{DD}	15V
Input Voltage Range, V_{IN}	-0.3V to $V_{DD} + 0.3V$
Continuous Collector Current, I_C	500mA
Package Power Dissipation:	
MIC5800 Plastic DIP (Note 1)	2.1W
MIC5801 Plastic DIP (Note 2)	2.5W
MIC5800 SOIC (Note 3)	1.0W
MIC5801 PLCC (Note 4)	2.25W
MIC5800 CERDIP (Note 5)	2.8W
MIC5801 CERDIP (Note 6)	3.1W
Operating Temperature Range, T_A	-40°C to +85°C
Storage Temperature Range, T_S	-65°C to +125°C

Note 1: Derate at 16.7 mW/°C above $T_A = +25^\circ\text{C}$

Note 2: Derate at 20 mW/°C above $T_A = +25^\circ\text{C}$

Note 3: Derate at 8.5 mW/°C above $T_A = +25^\circ\text{C}$

Note 4: Derate at 18.2 mW/°C above $T_A = +25^\circ\text{C}$

Note 5: Derate at 21.7 mW/°C above $T_A = +25^\circ\text{C}$

Note 6: Derate at 25 mW/°C above $T_A = +25^\circ\text{C}$

Note 7: Micrel CMOS devices have input-static protection but are susceptible to damage when exposed to extremely high static electrical charges.

Pin Configuration

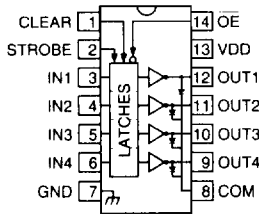

MIC5800BN, AJ, BM

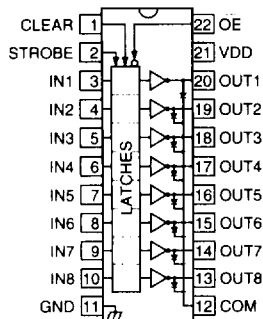

MIC5801BN, AJ

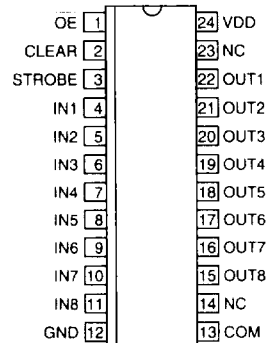

MIC5801BWM

Pin Configurations (continued)

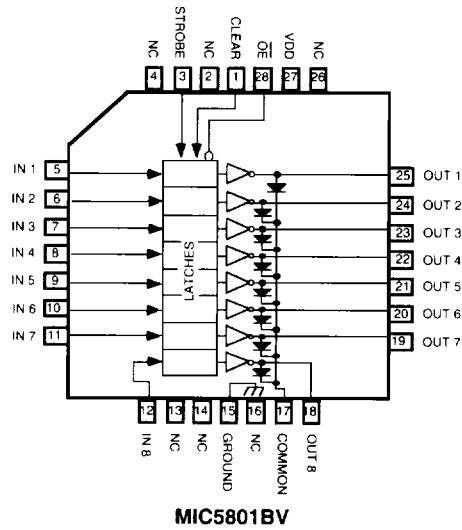

Allowable Output Current As A Function of Duty Cycle

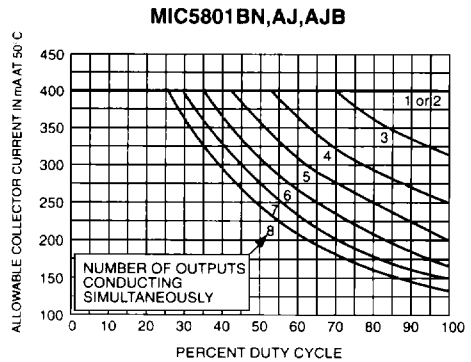
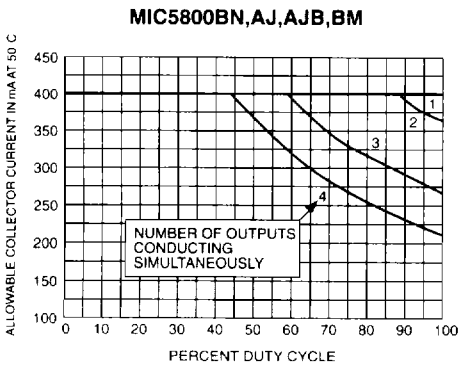

Electrical Characteristics: at $T_A = +25^\circ\text{C}$, $V_{DD} = 5\text{V}$ (unless otherwise noted)

Characteristic	Symbol	Test Conditions	Limits			Units
			Min.	Typ.	Max.	
Output Leakage Current	I_{CEX}	$V_{CE} = 50\text{ V}, T_A = +25^\circ\text{C}$			50	μA
		$V_{CE} = 50\text{ V}, T_A = +70^\circ\text{C}$			100	
Collector-Emitter Saturation Voltage	$V_{CE(SAT)}$	$I_C = 100\text{ mA}$		0.9	1.1	V
		$I_C = 200\text{ mA}$		1.1	1.3	
		$I_C = 350\text{ mA}, V_{DD} = 7.0\text{ V}$		1.3	1.6	
Input Voltage	$V_{IN(0)}$				1.0	V
		$V_{DD} = 12\text{ V}$	10.5			
		$V_{DD} = 10\text{ V}$	8.5			
		$V_{DD} = 5.0\text{ V}$ (See Note)	3.5			
Input Resistance	R_{IN}	$V_{DD} = 12\text{ V}$	50	200		$\text{k}\Omega$
		$V_{DD} = 10\text{ V}$	50	300		
		$V_{DD} = 5.0\text{ V}$	50	600		
Supply Current	$I_{DD(ON)}$ (Each Stage)	$V_{DD} = 12\text{ V}, \text{Outputs Open}$		1.0	2.0	mA
		$V_{DD} = 10\text{ V}, \text{Outputs Open}$		0.9	1.7	
		$V_{DD} = 5.0\text{ V}, \text{Outputs Open}$		0.7	1.0	
	$I_{DD(OFF)}$ (Total)	$V_{DD} = 12\text{ V}, \text{Outputs Open}, \text{Inputs} = 0\text{ V}$			200	μA
		$V_{DD} = 5.0\text{ V}, \text{Outputs Open}, \text{Inputs} = 0\text{ V}$		50	100	
Clamp Diode Leakage Current	I_R	$V_R = 50\text{ V}, T_A = +25^\circ\text{C}$			50	μA
		$V_R = 50\text{ V}, T_A = +70^\circ\text{C}$			100	
Clamp Diode Forward Voltage	V_F	$I_F = 350\text{ mA}$		1.7	2.0	V

NOTE : Operation of these devices with standard TTL or DTL may require the use of appropriate pull-up resistors to insure a minimum logic "1".

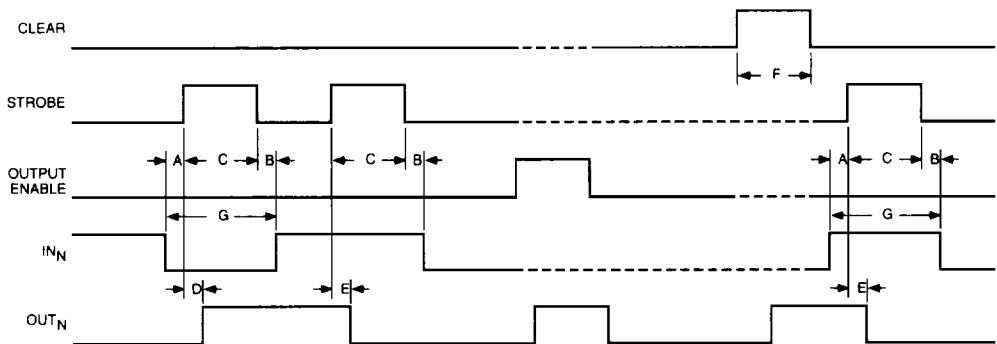

Timing Conditions

(Logic Levels are V_{DD} and Ground)

- A. Minimum data active time before strobe enabled (data set-up time) 50 ns
- B. Minimum data active time after strobe disabled (data hold time) 50 ns
- C. Minimum strobe pulse width 125 ns
- D. Typical time between strobe activation and output on to off transition 500 ns
- E. Typical time between strobe activation and output off to on transition 500 ns
- F. Minimum clear pulse width 300 ns
- G. Minimum data pulse width 225 ns

Truth Table

IN _N	Strobe	Clear	Output Enable	OUT _N	
				t-1	t
0	1	0	0	X	OFF
1	1	0	0	X	ON
X	X	1	X	X	OFF
X	X	X	1	X	OFF
X	0	0	0	ON	ON
X	0	0	0	OFF	OFF

X = Irrelevant
 t-1 = previous output state
 t = present output state

Information present at an input is transferred to its latch when the STROBE is high. A high CLEAR input will set all latches to the output OFF condition regardless of the data or STROBE input levels. A high OUTPUT ENABLE will set all outputs to the off condition, regardless of any other input conditions. When the OUTPUT ENABLE is low, the outputs depend on the state of their respective latches.

Typical Application

Unipolar Stepper-Motor Drive

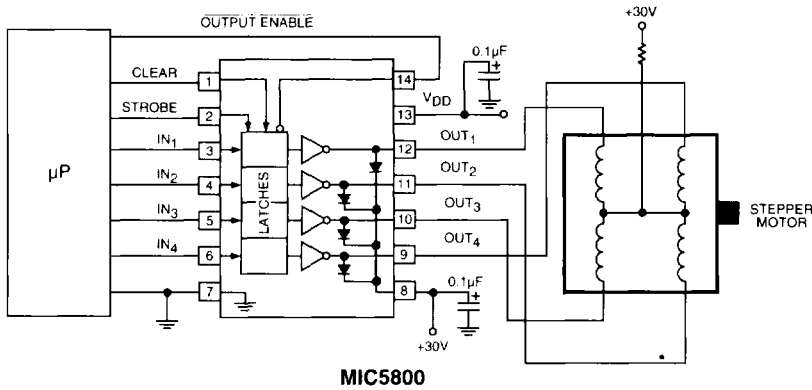

UNIPOLAR WAVE DRIVE

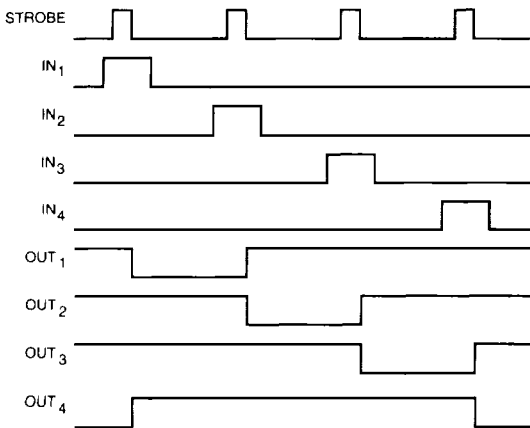

UNIPOLAR 2-PHASE DRIVE

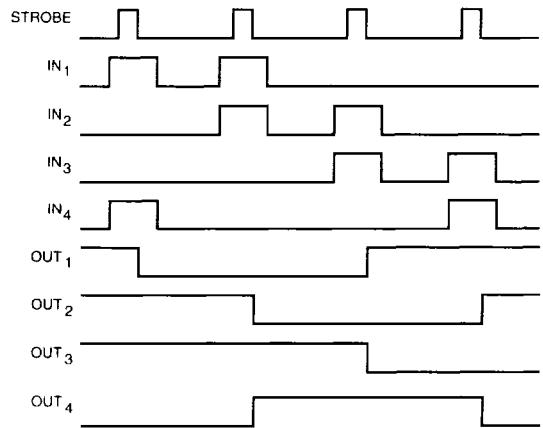

Typical Applications, Continued

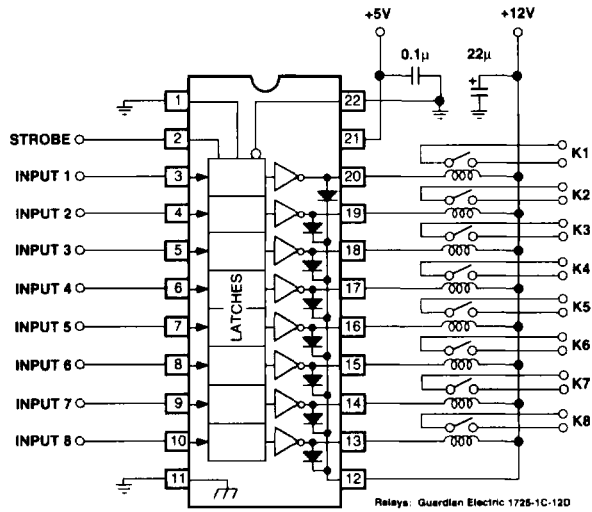

MIC5801 Relay Driver

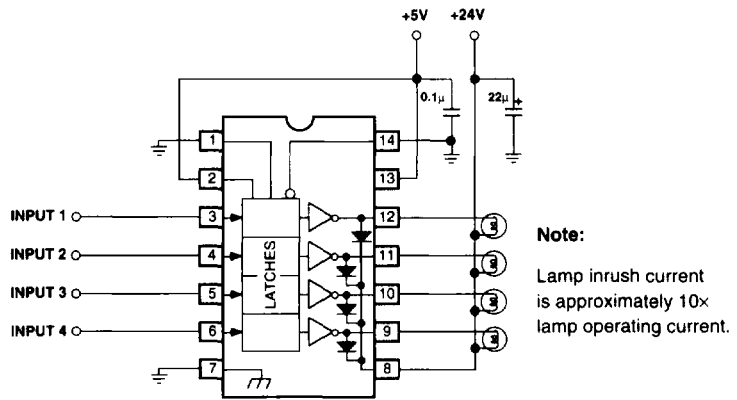

MIC5800 Incandescent/Halogen Lamp Driver