

The TQ8015 is a non-blocking 16 x 16 digital crosspoint switch capable of data rates greater than 1.25 Gigabits per second per port. Utilizing a fully differential internal data path and ECL I/O, the TQ8015 offers a high data rate with exceptional signal fidelity. The symmetrical switching and noise rejection characteristics inherent in differential logic result in low jitter and signal skew. The TQ8015 is ideally suited for digital video, data communications and telecommunication switching applications.

The non-blocking architecture uses 16 fully independent 16:1 multiplexers (see diagram on page 2), allowing each output port to be independently programmed to any input port. The switch is configured by sequentially loading each multiplexer's 4-bit program latch (OA0:3) with the desired input port address (IA0:3) and enabling the LOAD pin. When complete, the CONFIGURE pin is strobed and all new configurations are simultaneously transferred into the switch multiplexers. Data integrity is maintained on all unchanged data paths.

### Electrical Characteristics

	Min	Max	Units
Data Rate/Port	1.25		Gb/s
Jitter		150	ps peak-peak
Channel Propagation Delay		2000	ps
Ch-to-Ch Propagation Delay Skew		500	ps

## TQ8015

### 1.25 Gigabit/sec 16x16 Digital ECL Crosspoint Switch

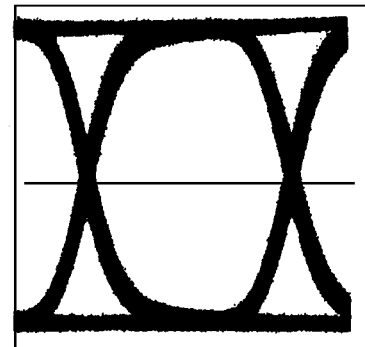

Typical output waveform with all channels driven

### Features

- >20 Gb/s aggregate BW
- 1.25 Gb/s/port NRZ data rate
- Non-blocking architecture
- 500 ps delay match
- Differential ECL-level data I/O; CMOS-level control inputs
- Low jitter and signal skew
- Fully differential data path
- Double buffered configuration latches
- 132-pin MQFP package

### Applications

Telecom/Datacom Switching  
Hubs and Routers  
Video Switching

# TQ8015

Figure 1. TQ8015 architecture.

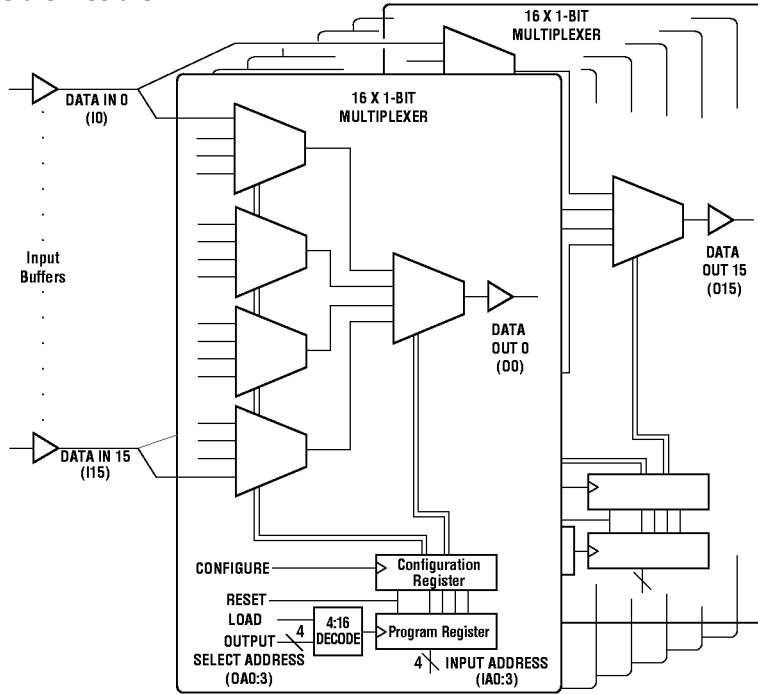

Table 1. Absolute Maximum Ratings<sup>5</sup>

Symbol	Parameter	Absolute Max. Rating	Notes
T <sub>STOR</sub>	Storage Temperature	-65° C to +150° C	
T <sub>CH</sub>	Junction (Channel) Temperature	-65° C to +150° C	1
T <sub>C</sub>	Case Temperature Under Bias	-65° C to +125° C	2
V <sub>CC</sub>	Supply Voltage	0 V to +7 V	3
V <sub>EE</sub>	Supply Voltage	-7 V to 0 V	3
V <sub>TT</sub>	Load Termination Supply Voltage	V <sub>EE</sub> to 0 V	4
V <sub>IN</sub>	Voltage Applied to Any ECL Input; Continuous	V <sub>EE</sub> -0.5 V to +0.5 V	
I <sub>IN</sub>	Current Into Any ECL Input; Continuous	-1.0 mA to +1.0 mA	
V <sub>IN</sub>	Voltage Applied to Any CMOS Input; Continuous	-0.5 V to V <sub>CC</sub> +0.5 V	
I <sub>IN</sub>	Current Into Any CMOS Input; Continuous	-1.0 mA to +1.0 mA	
V <sub>OUT</sub>	Voltage Applied to Any ECL Output	V <sub>EE</sub> -0.5 V to +0.5 V	4
I <sub>OUT</sub>	Current From Any ECL Output; Continuous	-40 mA	
P <sub>D</sub>	Power Dissipation per Output P <sub>OUT</sub> = (GND - V <sub>OUT</sub> ) x I <sub>OUT</sub>	50 mW	

- Notes:
1. For die applications.
  2. T<sub>C</sub> is measured at case top.
  3. All voltages specified with respect to GND, defined as 0V.
  4. Subject to I<sub>OUT</sub> and power dissipation limitations.
  5. Absolute maximum ratings, as detailed in this table, are the ratings beyond which the device's performance may be impaired and/or permanent damage to the device may occur.

**Table 2. Recommended Operating Conditions<sup>3</sup>**

Symbol	Parameter	Min	Typ	Max	Units	Notes
T <sub>C</sub>	Case Operating Temperature	0		85	°C	1
V <sub>CC</sub>	Supply Voltage	4.5		5.5	V	
V <sub>EE</sub>	Supply Voltage	-5.5		-4.5	V	
V <sub>TT</sub>	Load Termination Supply Voltage		-2.0		V	2
R <sub>LOAD</sub>	Output Termination Load Resistance		50		Ω	2
Θ <sub>JC</sub>	Thermal Resistance Junction to Case			7	°C/W	

Notes: 1. T<sub>C</sub> measured at case top. Use of adequate heatsink is required.  
 2. The V<sub>TT</sub> and R<sub>LOAD</sub> combination is subject to maximum output current and power restrictions.  
 3. Functionality and/or adherence to electrical specifications is not implied when the device is subjected to conditions that exceed, singularly or in combination, the operating range specified.

**Table 3. Pin Descriptions**

Signal	Name/Level	Description																														
I0 to I15, NI0 to NI15	Data input true and complement. Differential ECL	Differential data input ports.																														
O0 to O15, NO0 to NO15	Data output true and complement. Differential ECL	Differential data output ports.																														
IA0:3	Input address, CMOS	Input port selection address that is written into the selected output port program latches (OA0:3). <table border="1" style="margin-left: auto; margin-right: auto;"> <thead> <tr> <th>IA3</th> <th>IA2</th> <th>IA1</th> <th>IA0</th> <th>Input port</th> </tr> </thead> <tbody> <tr> <td>0</td> <td>0</td> <td>0</td> <td>0</td> <td>0</td> </tr> <tr> <td>0</td> <td>0</td> <td>0</td> <td>1</td> <td>1</td> </tr> <tr> <td>0</td> <td>0</td> <td>1</td> <td>0</td> <td>2</td> </tr> <tr> <td>:</td> <td>:</td> <td>:</td> <td>:</td> <td>:</td> </tr> <tr> <td>1</td> <td>1</td> <td>1</td> <td>1</td> <td>15</td> </tr> </tbody> </table>	IA3	IA2	IA1	IA0	Input port	0	0	0	0	0	0	0	0	1	1	0	0	1	0	2	:	:	:	:	:	1	1	1	1	15
IA3	IA2	IA1	IA0	Input port																												
0	0	0	0	0																												
0	0	0	1	1																												
0	0	1	0	2																												
:	:	:	:	:																												
1	1	1	1	15																												
OA0:3	Output select address, CMOS	Output port selection address. Selects the output port program latches to which the input port selection address (IA0:3) is written. <table border="1" style="margin-left: auto; margin-right: auto;"> <thead> <tr> <th>OA3</th> <th>OA2</th> <th>OA1</th> <th>OA0</th> <th>Output port</th> </tr> </thead> <tbody> <tr> <td>0</td> <td>0</td> <td>0</td> <td>0</td> <td>0</td> </tr> <tr> <td>0</td> <td>0</td> <td>0</td> <td>1</td> <td>1</td> </tr> <tr> <td>0</td> <td>0</td> <td>1</td> <td>0</td> <td>2</td> </tr> <tr> <td>:</td> <td>:</td> <td>:</td> <td>:</td> <td>:</td> </tr> <tr> <td>1</td> <td>1</td> <td>1</td> <td>1</td> <td>15</td> </tr> </tbody> </table>	OA3	OA2	OA1	OA0	Output port	0	0	0	0	0	0	0	0	1	1	0	0	1	0	2	:	:	:	:	:	1	1	1	1	15
OA3	OA2	OA1	OA0	Output port																												
0	0	0	0	0																												
0	0	0	1	1																												
0	0	1	0	2																												
:	:	:	:	:																												
1	1	1	1	15																												
LOAD	CMOS	Enables the selected output port program latches while set 'high'. Latches the data when set to a 'low' level.																														
CONFIGURE	CMOS	Transfers the program latches data to the configuration latches and implements the switch changes while set 'high'. Latches the data when set to a 'low' level.																														
RESET	CMOS	Sets the switch into broadcast or pass-through configuration, overwriting existing configurations. <i>Broadcast mode:</i> All output ports are connected to data input port 0. This mode is selected by applying a RESET "high" pulse with CONFIGURE held "low".																														

## TQ8015

**Table 4. DC Characteristics<sup>1</sup>** – Within recommended operating conditions, unless otherwise indicated.

Symbol	Parameter	Min	Max	Units	Test Cond.	Notes
V <sub>IH</sub>	ECL Input Voltage High	-1100	-500	mV		
V <sub>IL</sub>	ECL Input Voltage Low	V <sub>TT</sub>	-1500	mV		
I <sub>IH</sub>	ECL Input Current High		+30	μA	V <sub>IH</sub> = -0.7 V	
I <sub>IL</sub>	ECL Input Current Low	-30		μA	V <sub>IL</sub> = -2.0 V	
V <sub>ICM</sub>	ECL Input Common Mode Voltage	-1500	-1100	mV		
V <sub>IDIF</sub>	ECL Input Differential Voltage (pk-pk)	400	1200	mV		
V <sub>IH</sub>	CMOS Input Voltage High	3.5	V <sub>CC</sub>	V		
V <sub>IL</sub>	CMOS Input Voltage Low	0	1.5	V		
I <sub>IH</sub>	CMOS Input Current High		+100	μA	V <sub>IH</sub> = V <sub>CC</sub>	
I <sub>IL</sub>	CMOS Input Current Low		-100	μA	V <sub>IL</sub> = 0 V	
V <sub>OCM</sub>	ECL Output Common Mode	-1500	-1100	mV		
V <sub>ODIF</sub>	ECL Output Differential Voltage	600		mV		
V <sub>OH</sub>	ECL Output Voltage High	-1000	-600	mV		
V <sub>OL</sub>	ECL Output Voltage Low	V <sub>TT</sub>	-1600	mV		
I <sub>OH</sub>	ECL Output Current High	20	27	mA		
I <sub>OL</sub>	ECL Output Current Low	0	8	mA		
I <sub>CC</sub>	Power Supply Current (+)		20	mA		
I <sub>EE</sub>	Power Supply Current (-)		-950	mA		

Notes: 1. Test conditions unless otherwise indicated: V<sub>TT</sub> = -2.0 V, R<sub>LOAD</sub> = 50 W to V<sub>TT</sub>.

**Table 5. AC Characteristics<sup>1</sup>** – Within recommended operating conditions, unless otherwise indicated.

Symbol	Parameter	Min	Typ	Max	Units	Notes
	Maximum Data Rate/Port			1.25	Gb/s	1,2
	Jitter			150	ps pk-pk	1
T <sub>1</sub>	Channel Propagation Delay			2000	ps	
T <sub>2</sub>	Ch-to-Ch Propagation Delay Skew			500	ps	
T <sub>3</sub>	CONFIG to Data Out (Oi) Delay			5	ns	
T <sub>4</sub>	LOAD Pulse Width	7			ns	
T <sub>5</sub>	CONFIG Pulse Width	7			ns	
T <sub>6</sub>	IAi to LOAD High Setup Time	0			ns	
T <sub>7</sub>	LOAD to IAi Low Hold Time	3			ns	
T <sub>8</sub>	OAi to LOAD High Setup Time	0			ns	
T <sub>9</sub>	LOAD to OAi Low Hold Time	3			ns	
T <sub>10</sub>	Load ↑ to CONFIG ↑	0			ns	
T <sub>11</sub>	RESET Pulse Width	10			ns	
T <sub>R,F</sub>	Output Rise or Fall Time		250	400	ps	3

Notes: 1. Test conditions: V<sub>TT</sub> = -2.0 V, R<sub>LOAD</sub> = 50 W to V<sub>TT</sub>; ECL inputs: V<sub>IH</sub> = -1.1 V; V<sub>IL</sub> = -1.5 V; CMOS inputs: V<sub>IH</sub> = 3.5 V, V<sub>IL</sub> = 1.5 V; ECL outputs: V<sub>OH</sub> ≥ -1.0 V, V<sub>OL</sub> ≤ -1.6 V; ECL inputs rise and fall times ≤ 1 ns; CMOS inputs rise and fall times ≤ 20 ns. A bit error rate of 1E-13 BER or better for 2<sup>23</sup>-1PRBS pattern, jitter and rise/fall times are guaranteed through characterization.

2. 1.2 Gb/s Non-Return-Zero (NRZ) data equivalent to 600 MHz clock signal.

3. Rise and fall times are measured at the 20% and 80% points of the transition from V<sub>OL</sub> max to V<sub>OL</sub> min.

Figure 2. Switch Configuration Timing

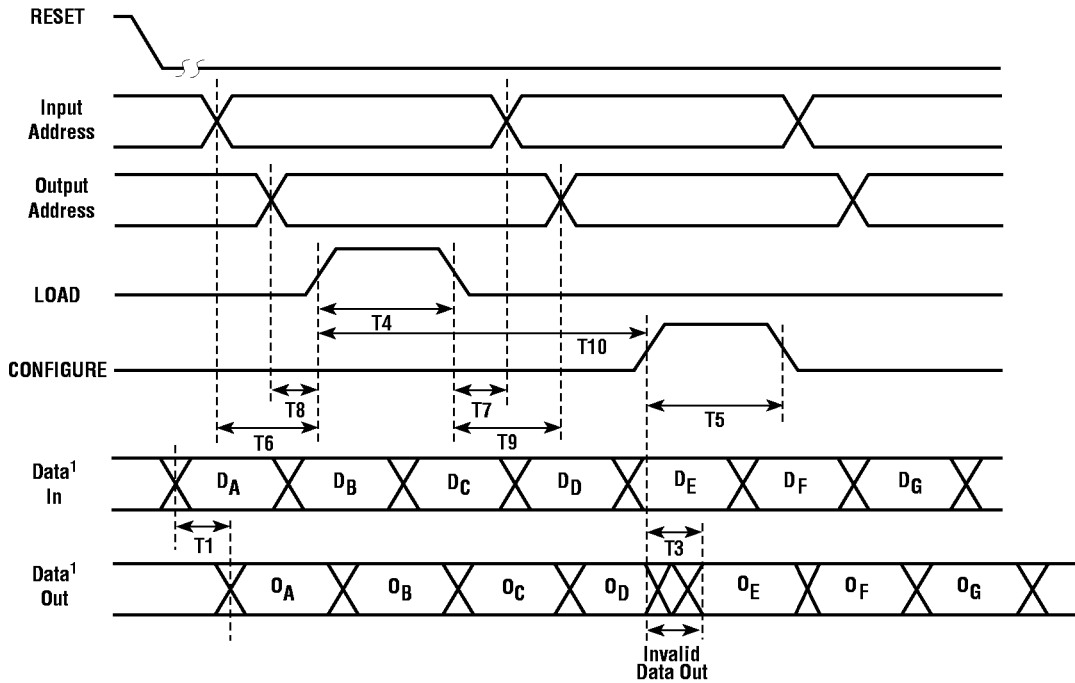

Notes: 1. No data loss on unchanged paths.

Figure 5. Reset Timing

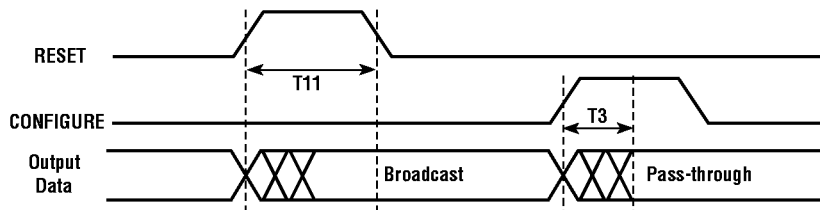

Notes: 1. LOAD input must remain LOW to insure correct programming of the switch.  
 2. "Broadcast" is defined as data input 0 to all data outputs (0...15).  
 3. "Pass-through" is defined as data input 0 to data output 0, data input 1 to data output 1, and so on.

SWITCHING PRODUCTS

**Typical Performance Data**

**Figure 4. Data Eye Closure**

Percent RMS vs. Data Rate (typical)

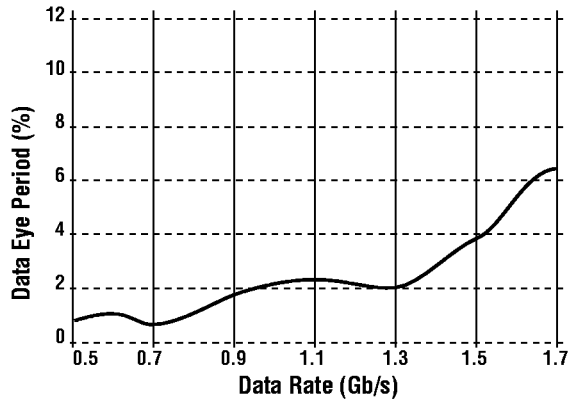

**Figure 5. Data Eye Closure**

Time & Amplitude vs Data Rate (typical)

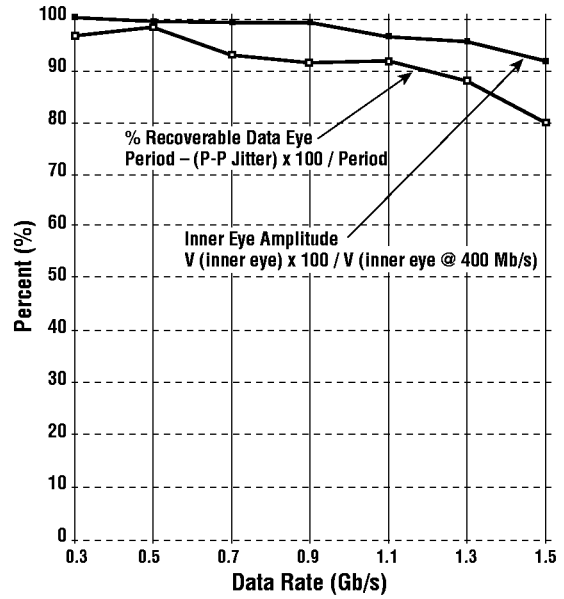

**Figure 6. RMS Jitter vs. Data Rate (typical)**

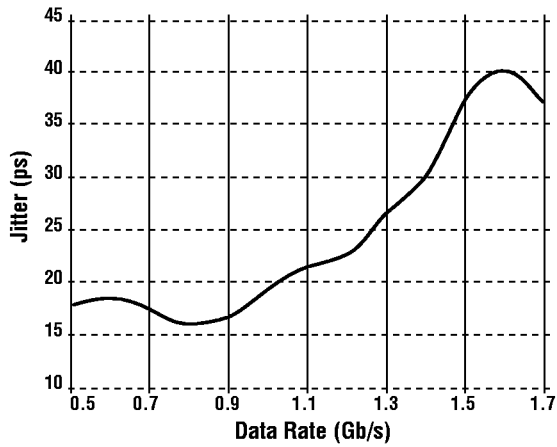
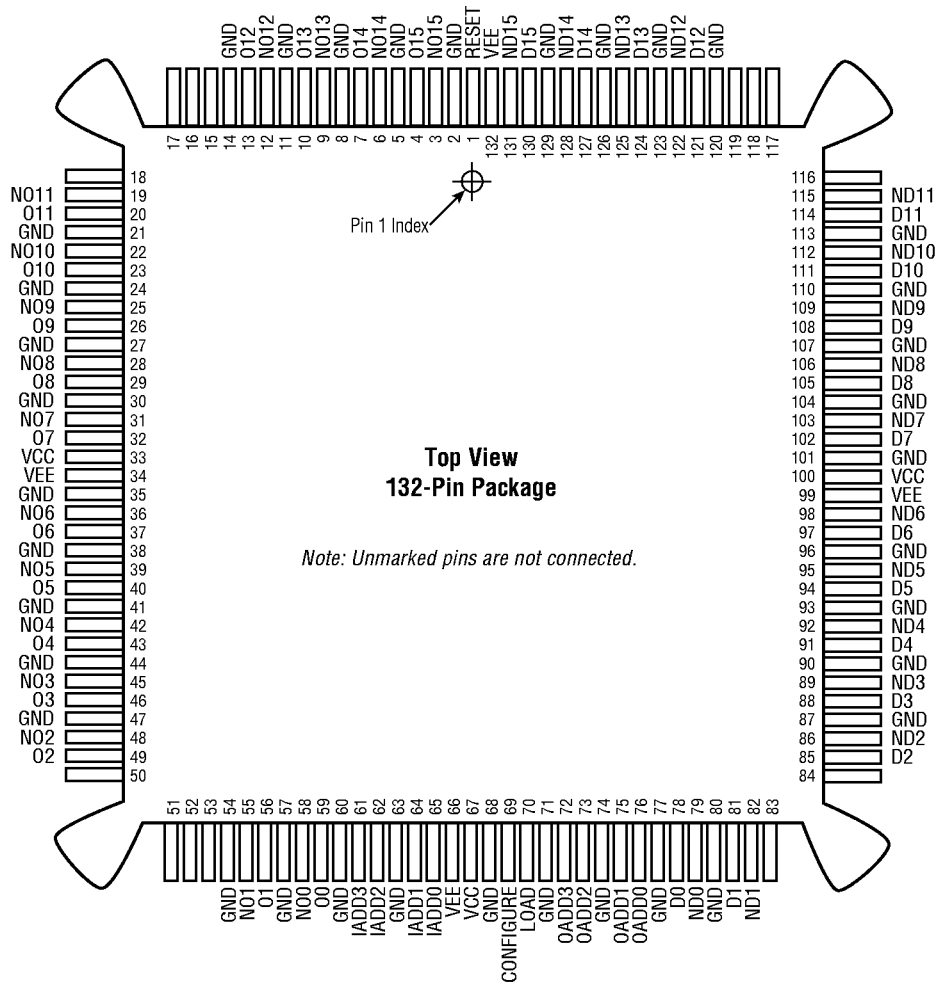
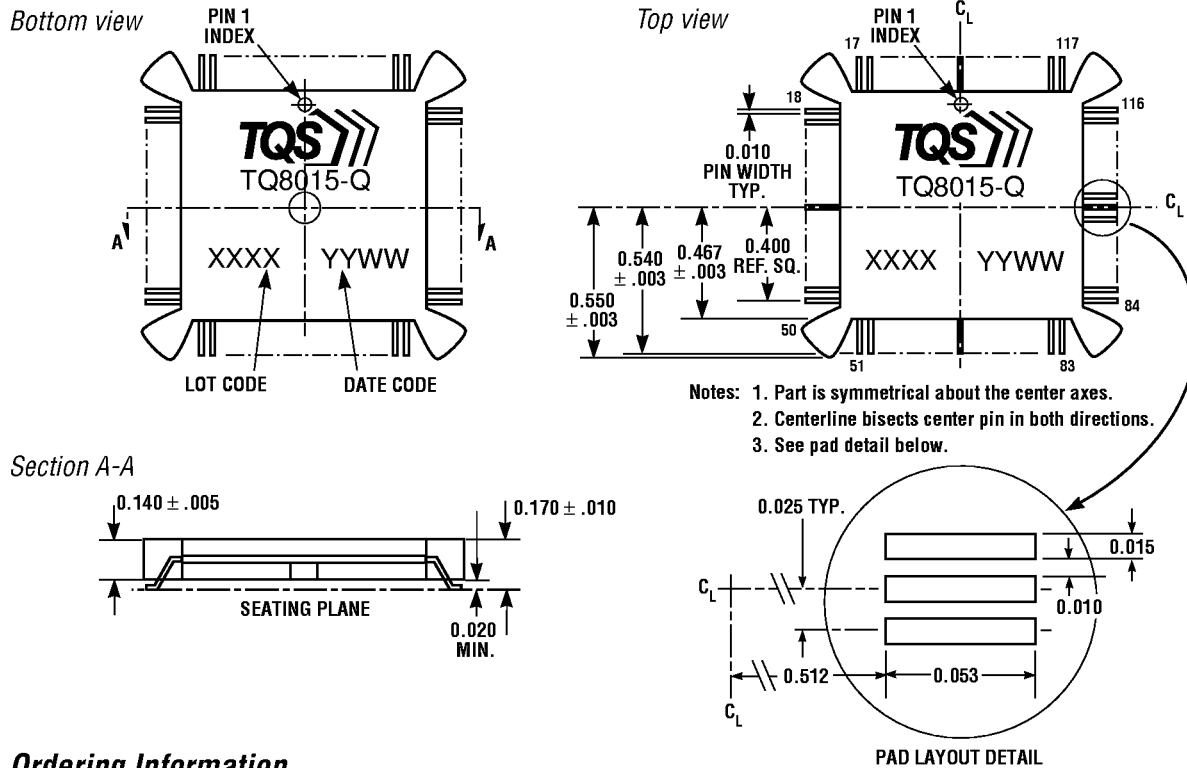

Figure 7. Package Pinout



# TQ8015

**Figure 8. Mechanical Dimensions (in inches)**



## Ordering Information

**TQ8015-Q** 1.25 16x16 Gb/s ECL Crosspoint Switch

## Additional Information

For latest specifications, additional product information, worldwide sales and distribution locations, and information about TriQuint:

**Web:** [www.triquint.com](http://www.triquint.com) **Tel:** (503) 615-9000  
**Email:** [sales@tqs.com](mailto:sales@tqs.com) **Fax:** (503) 615-8900

For technical questions and additional information on specific applications:

**Email:** [applications@tqs.com](mailto:applications@tqs.com)

The information provided herein is believed to be reliable; TriQuint assumes no liability for inaccuracies or omissions. TriQuint assumes no responsibility for the use of this information, and all such information shall be entirely at the user's own risk. Prices and specifications are subject to change without notice. No patent rights or licenses to any of the circuits described herein are implied or granted to any third party. TriQuint does not authorize or warrant any TriQuint product for use in life-support devices and/or systems.

Copyright © 1997 TriQuint Semiconductor, Inc. All rights reserved.  
 Revision 1.1.A November 1997