

STELVIOKONTEK
engineering & manufacturing

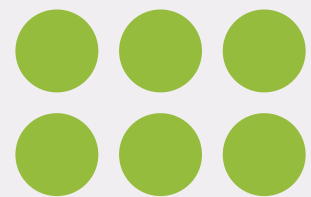

BLOCKS&go



MORSETTI E CONNETTORI PER C.S.
TERMINAL BLOCKS AND CONNECTORS FOR P.C.B.
BLOCS DE JONCTION ET CONNECTEURS POUR C.I.
PRINTKLEMMEN UND STECKVERBINDER FÜR LEITERPLATTEN

INNOVATION SUPPORTED BY A TRULY SOLID INDUSTRIAL ORGANIZATION.

Stelvio Kontek S.p.A. is one of the leading groups in the connectors market. With a solid background in the sector and having gained strength from the merger between Stelvio and Kontek Comatel in 2009, the group's ground-breaking production facilities and vertical organization result in high performance and innovation.

Technical experts operate in our in-house R&D department and at the production sites (Italy, Hungary, Romania) to transform sketches into reality.

The company designs, engineers and manufactures standardized & customized solutions using dedicated equipment, relying on its hi-tech facilities powered up with in-house technology.

Our products are type-tested in our laboratory, approved by the main international institutes (UL, VDE, IMQ) and comply with latest European directives (RoHS, WEEE, PFOS, REACH), ensuring that our commitment towards environment is consistent.

Simultaneously, our engagement *vis-à-vis* great missions is formalized through our constant and renewed support to the United Nation Global Compact.

Everyday, the group is proud to serve customers all over the world through its skilled rep's network, with the support of its central technical and sales offices.

This fully verticalized organization is our master tool that enables us to square things right. *Allo stato dell'arte.*

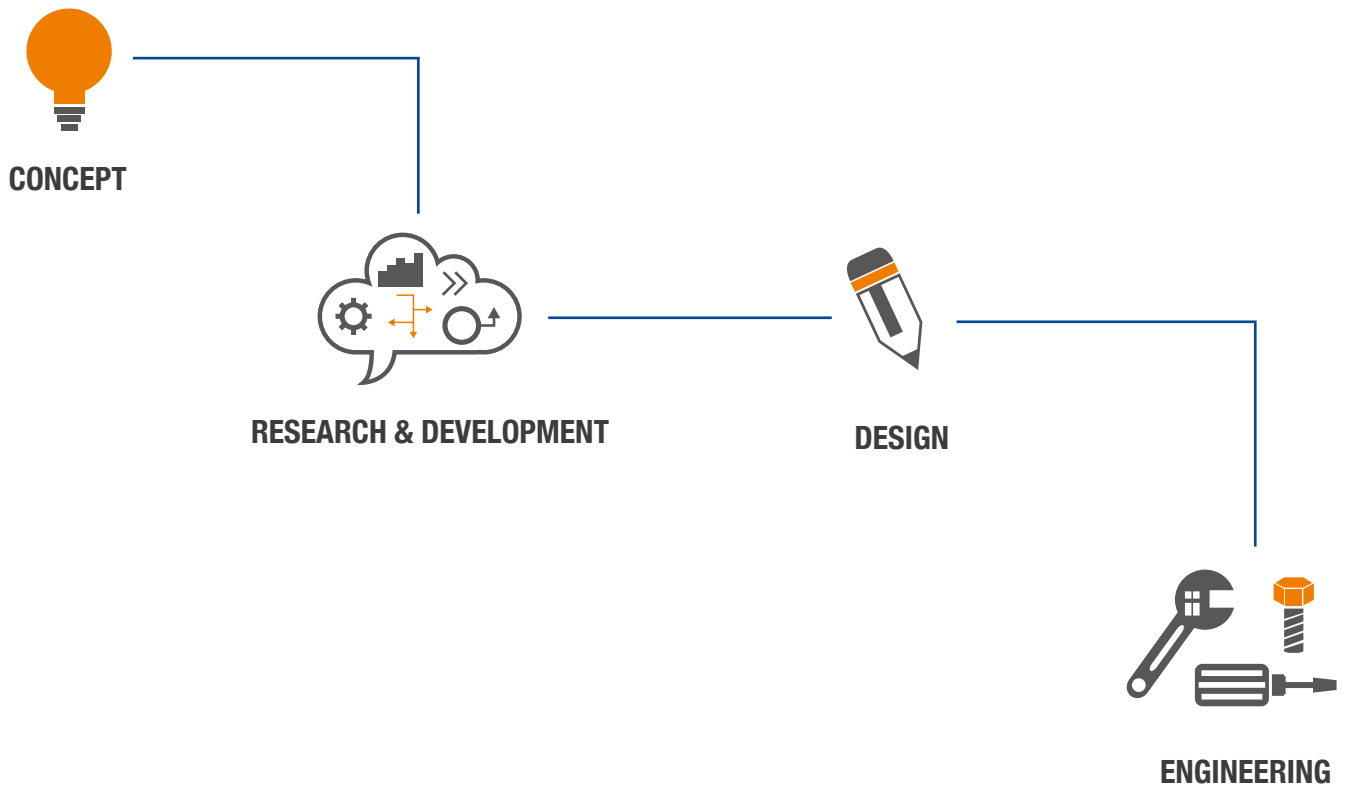

FULLY VERTICALIZED PRODUCTION.

Our structure is organised to satisfy even the most demanding customers needs from design to production and engineering.

We offer engineering, design and manufacturing of custom products with dedicated equipment, supported by a modern and fully verticalized structure and with all processes constantly under control. All of this thanks to unique in-house designed software's and hardware's. Stelvio Kontek follows the whole development process: from design to production, validation and commercialization.



▶ Scan the qr-code with your smartphone and discover the flow of Stelvio Kontek's products, from the idea to your hands.

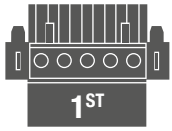

PROTOTYPING



PRODUCTION



STAMPING & CUTTING



PLASTIC MOULDING

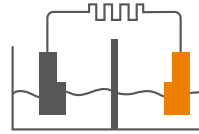

GALVANIC TREATMENT

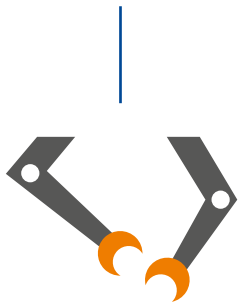

ASSEMBLING



QUALITY CONTROL



MARKETING



LOGISTICS







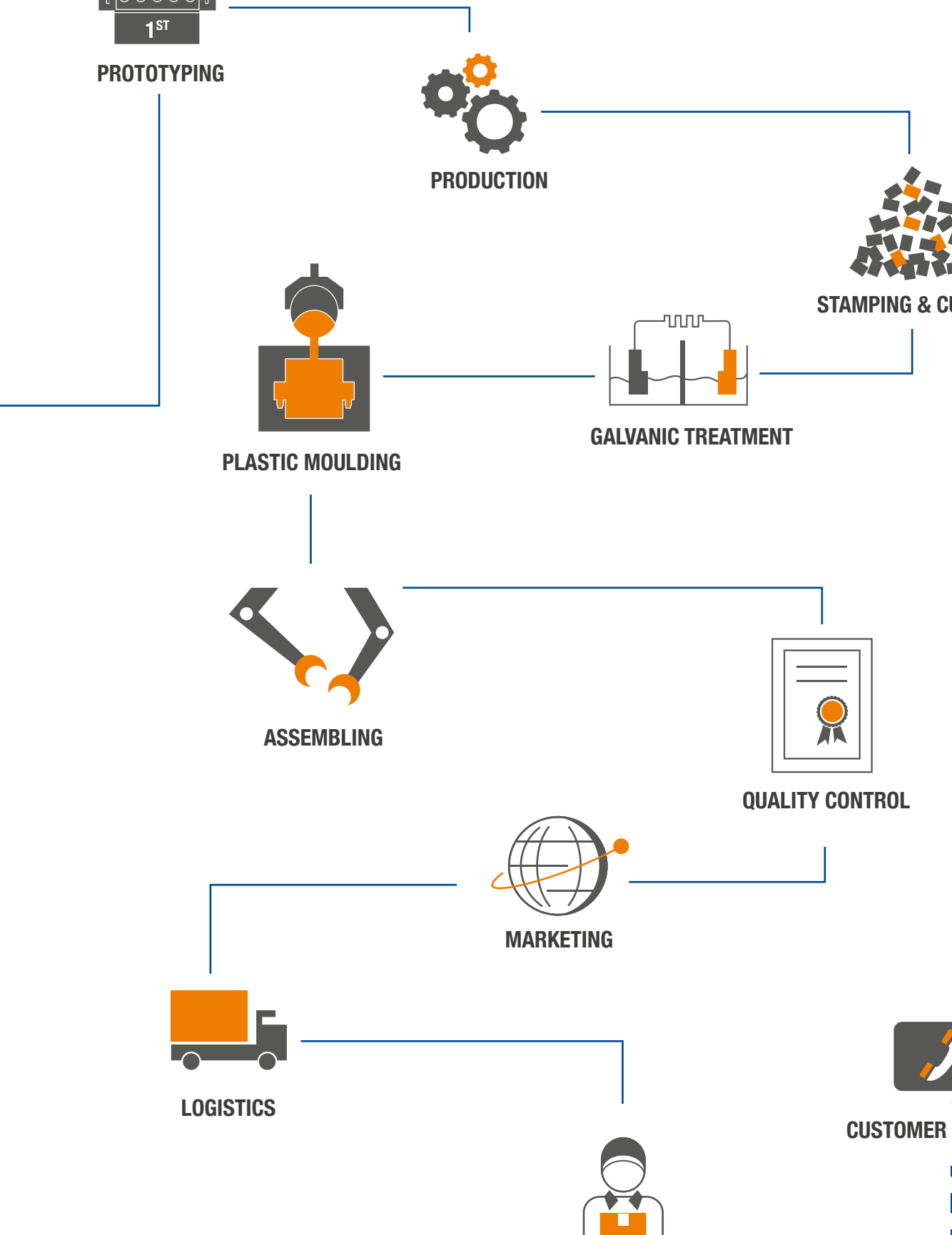

CUSTOMER SERVICE



DELIVERY



MORSETTI PER C.S. TERMINAL BLOCKS FOR P.C.B. BLOCS DE JONCTION POUR C.I. PRINTKLEMMEN		A carrello Rising clamp A étrier remontant Liftprinzip	5	A1
		A linguetta Wire protection A languette Drahtschutz	23	A2
		A molla Screwless A ressort Federkraft	31	A3
CONNETTORI PER C.S. CONNECTORS FOR P.C.B. CONNECTEURS POUR C.I. PRINT-STECKVERBINDER		Femmina a carrello Rising clamp female plug Femelle à étrier remontant Liftprinzip-Steckerteil	37	B1
		Femmina a molla Screwless female plug Femelle à ressort Federkraft-Steckerteil	49	B2
		Femmina a linguetta Wire protection female plug Femelle à languette Drahtschutz-Steckerteil	55	B3
		Maschio Header Mâle Stiftleiste	57	B4
ACCESSORI - NUOVI PRODOTTI IN FASE DI SVILUPPO - DESIGN IN ACCESSORIES - NEW PRODUCTS UNDER DEVELOPMENT - DESIGN IN ACCESSOIRES - EN COURS DE DÉVELOPPEMENT - DESIGN IN ZUBEHÖR - NEUPRODUKTE IN ENTWICKLUNG - DESIGN IN			66	C
DATI TECNICI TECHNICAL DATA DONNÉES TECHNIQUES TECHNISCHE DATEN			71	D
TABELLE TABLES TABLEAUX TABELLEN			103	E

Morsetti per C.S. a carrello

Terminal blocks for P.C.B. rising clamp

Blocs de jonction C.I. étrier remontant

Printklemmen Liftprinzip



Tornito
Turned
Usiné
Gedreht



Tranciato
Punched
Découpé
Gestanzt

Pag.	Tipo Type Typ				Tornito Turned Usiné Gedreht	Tranciato Punched Découpé Gestanzt		GWT*	THR*	Passo Pitch Pas Rastermaß												
										3,5	3,81	5	5,08	6,35	7	7,5	7,62	8	9,52	10	10,16	
6	CPP	•	•	•	•	•	•	V	V	•	•				•	•						
7	CPA	•	•	•	•	•	•	V	V	•	•				•	•						
7-8	COB			•	•	•	•	V	V				•	•							•	•
8-9	CII	•	•	•	•	•	•	V	V				•	•							•	•
9	CIA	•	•	•	•	•	•	V	V				•	•							•	•
10-11	CLL	•	•	•	•	•	•	V	V				•	•		•	•				•	•
11-12	CLA	•	•	•	•	•	•	V	V				•	•		•					•	•
12-13	MRT4	•	•	•	•	•	•	V					•									•
13	CUU	•	•	•	•	•	•	•					•									•
14-16	MRT5	•	•	•	•	•	•	V					•	•		•	•				•	•
16-17	MRT15	•	•	•	•	•	•	V					•	•							•	•
18	MRT6	•		•	•	•	•	V					•									•
19-20	MRT18	•		•	•	•	•	V					•									•
20	MRT20	•			•	•	•	V						•							•	
21	MRT19	•		•	•	•	•	V													•	
21	MRT26	•			•	•	•	•														•
21	MRT27	•			•	•	•	•														•

Numerazione a richiesta.
Vite con testa a croce su richiesta.

Printing on request.
Combi head screw on request.

Numérotation suivant demande.
Vis avec empreinte cruciforme suivant demande.

Bedruckung nach Kundenwunsch.
Kombischraube auf Anfrage.

GWT*
● Versione standard compatibile / Standard version compliant / Version standard compatible / Standardversion Kompatibel
V A richiesta / On demand / Sur demande / bei Bedarf

THR*
V A richiesta / On demand / Sur demande / bei Bedarf

* Vedi dati tecnici / See technical data / cf. données techniques / siehe technische Daten

Morsetti per C.S. carrello

Terminal blocks for P.C.B. rising clamp

Blocs de jonction C.I. étrier remontant

Printklemmen Liftprinzip

Passo Pas	Pitch Rastermaß	mm
Tensione nominale Tension nominale	Rated Voltage Bemessungsspannung	V
Corrente nominale Intensité nominale	Rated Current Bemessungsstrom	A
Tipo cavi Type du conducteur	Types of cables Leitungstypen	
Sezione nominale Section nominale	Nominal cross section Nennquerschnitt	mm ² AWG
Lunghezza spelatura Longueur de dénudage	Stripping length Abisolierlänge	mm
Coppia di torsione Couple de serrage	Torque Drehmoment	Nm Lb-in
Temperatura Température	Temperature Temperatur	°C
Corpo isolante Corps isolant	Housing Isolierkörper	
Vite Imperdibile Vis Imperdable	Captive Screw Unverlierbare Schraube	

	IMQ	EN60998
	VDE	EN60998
	cUL	UL1059 + C22.2 n°158

Poli Pôles	Poles Polzahl	X
Colore standard Coloris standard	Standard colour Standardfarbe	Y
Altri dati Autres données	Other information Weitere Informationen	Pag Seite

Ordinazione Référence de commande	How to order Bestellschlüssel
CPP 3,5 / X	SQ Y N...
Tipo	Versione
Type	Version
Type	Version
Typ	Version

Altri colori a richiesta Autres couleurs sur demande	Other colours on demand Andere Farben bei Bedarf
VE GR NE AR BL RO	

CPP CPP..SQ

Modulo componibile Elements modulaires Interlocking modules Zusammensteckbare Blöcke

Poli Pôles Poles Polzahl 2/3

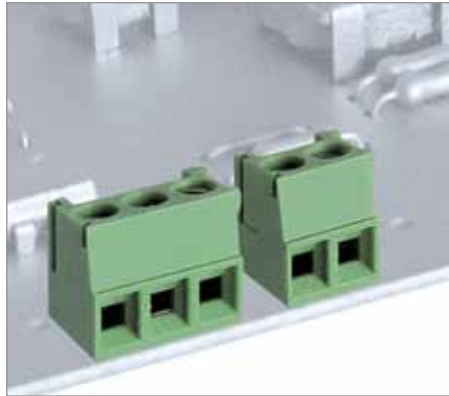

3,5	3,81
160	
10	
0,2 ÷ 1,5 30 ÷ 16	0,2 ÷ 1 30 ÷ 16
6	
0,3	1,5
110	
PA - UL 94 VO	
M2	
0,5 x 2,5	

V	A	mm²/AWG
130	10	0,2 ÷ 1
130	10	0,2 ÷ 1
300	10	30 ÷ 16

min 2 - max...
VE
D/A1

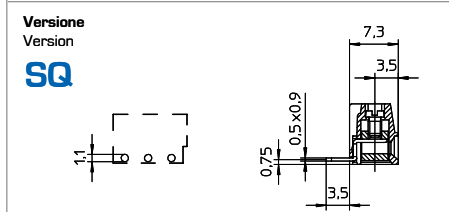
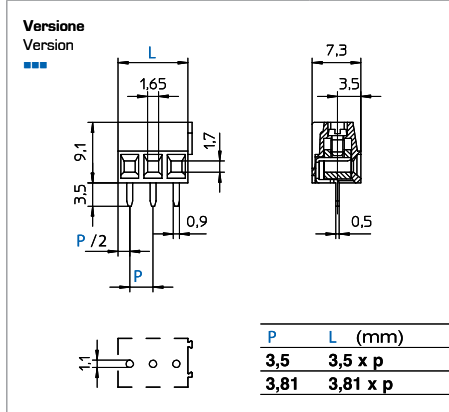

CPP CPP..SQ

Modulo componibile Elements modulaires Interlocking modules Zusammensteckbare Blöcke

Poli Pôles Poles Polzahl 1/2

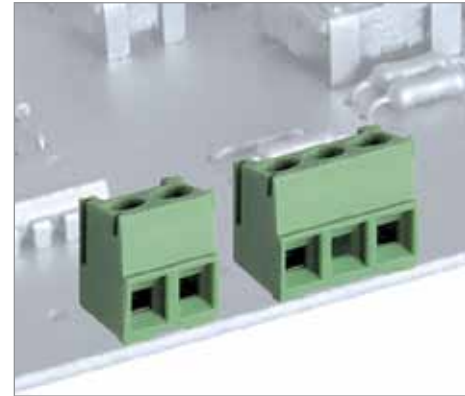

7	7,62
400	500
10	
0,2 ÷ 1,5 30 ÷ 16	0,2 ÷ 1 30 ÷ 16
6	
0,3	1,5
110	
PA - UL 94 VO	
M2	
0,5 x 2,5	

V	A	mm²/AWG
450	10	0,2 ÷ 1
450	10	0,2 ÷ 1
300	10	30 ÷ 18

min 2 - max...
VE
D/A1

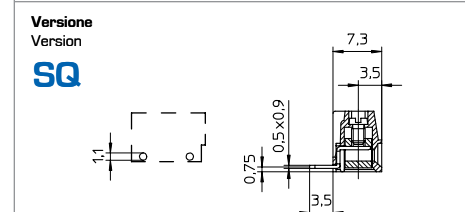
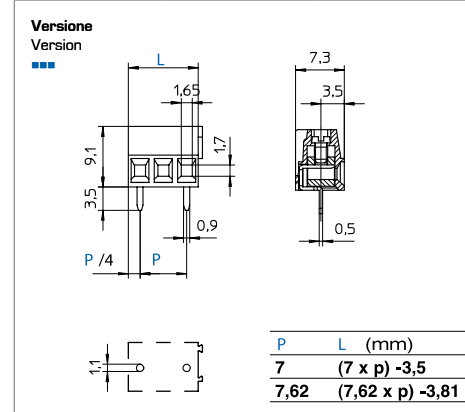

CPA **CPA..SQ**

Blocco unico / Single block
Monobloc / Einzelblock

Poli / Poles: 2/20
Póles / Polzahl

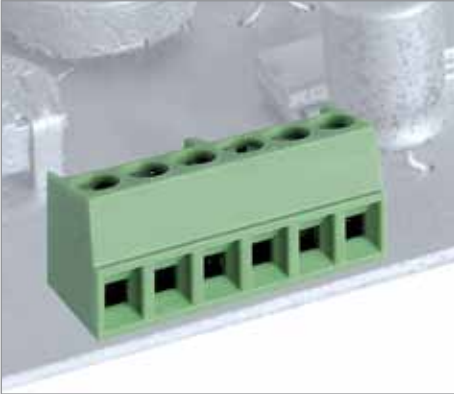

3,5	3,81
160	
10	

0,2 ÷ 1,5 30 ÷ 16	0,2 ÷ 1 30 ÷ 16	0,2 ÷ 1 30 ÷ 16
6		
0,3	/	2,5
110		
PA - UL 94 VO		
M2		
	0,5 x 2,5	

V	A	mm ² /AWG
130	10	0,2 ÷ 1
130	10	0,2 ÷ 1
300	10	30 ÷ 16

min 2 - max 20
VE
D/A1

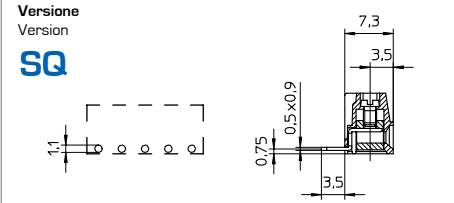
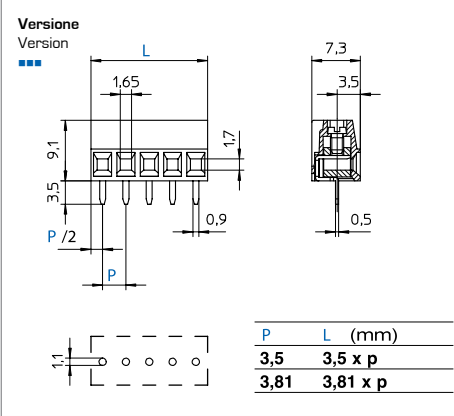

CPA **CPA..SQ**

Blocco unico / Single block
Monobloc / Einzelblock

Poli / Poles: 2/10
Póles / Polzahl

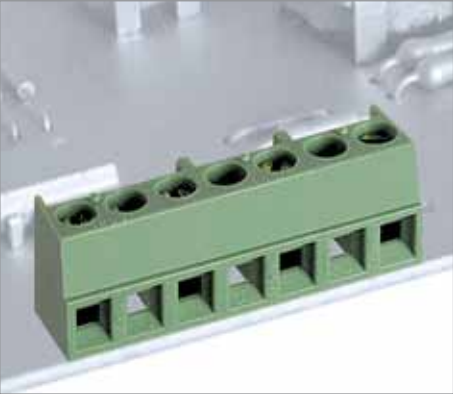

7	7,62
400	500
10	

0,2 ÷ 1,5 30 ÷ 16	0,2 ÷ 1 30 ÷ 16	0,2 ÷ 1 30 ÷ 16
6		
0,3	/	2,5
110		
PA - UL 94 VO		
M2		
	0,5 x 2,5	

V	A	mm ² /AWG
450	10	0,2 ÷ 1
450	10	0,2 ÷ 1
300	10	30 ÷ 18

min 2 - max 10
VE
D/A1

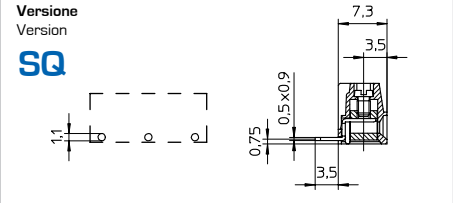
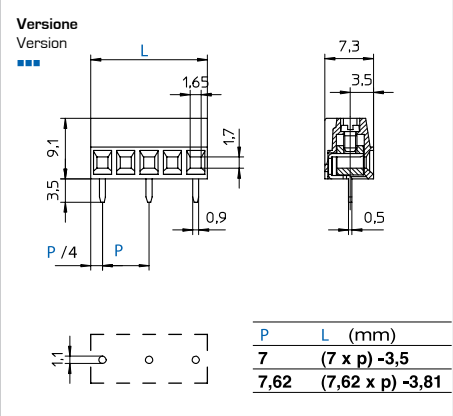

COB

Modulo componibile / Interlocking modules
Elements modulaires / Zusammensteckbare Blöcke

Poli / Poles: 2/3
Póles / Polzahl

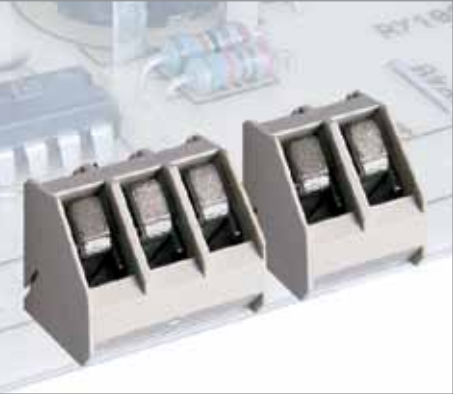

5	5,08
160	
24	

0,2 ÷ 4 30 ÷ 12	0,2 ÷ 2,5 30 ÷ 12	0,2 ÷ 2,5 30 ÷ 12
6		
0,5	/	4
110		
PA - UL 94 VO		
M3		
	0,6 x 3,5	

V	A	mm ² /AWG
130	24	0,5 ÷ 2,5
130	24	0,5 ÷ 2,5
300	16	24 ÷ 12

min 2 - max...
GR
D/A1

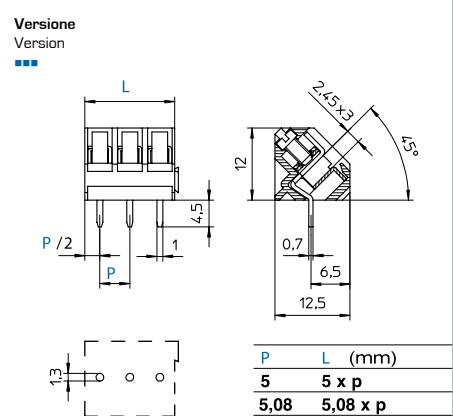

Morsetti per C.S. carrello

Terminal blocks for P.C.B. rising clamp

Blocs de jonction C.I. étrier remontant

Printklemmen Liftprinzip

Passo Pas	Pitch Rastermaß	mm
Tensione nominale Tension nominale	Rated Voltage Bemessungsspannung	V
Corrente nominale Intensité nominale	Rated Current Bemessungsstrom	A
Tipo cavi Type du conducteur	Types of cables Leitungstypen	
Sezione nominale Section nominale	Nominal cross section Nennquerschnitt	mm ² AWG
Lunghezza spelatura Longueur de dénudage	Stripping length Abisolierlänge	mm
Coppia di torsione Couple de serrage	Torque Drehmoment	Nm Lb-in
Temperatura Température	Temperature Temperatur	°C
Corpo isolante Corps isolant	Housing Isolierkörper	
Vite Imperdibile Vis Imperdable	Captive Screw Unverlierbare Schraube	

	IMQ	EN60998
	VDE	EN60998
	cUL	UL1059 + C22.2 n°158

Poli Pôles	Poles Polzahl	X
Colore standard Coloris standard	Standard colour Standardfarbe	Y
Altri dati Autres données	Other information Weitere Informationen	Pag Seite

Ordinazione Référence de commande	How to order Bestellschlüssel				
COB 10 / X ... Y N...					
Tipo Type	Passo Pitch	Poli Poles	Versione Version	Colori Couleurs	Numerazione Marquage
Type	Pas	Pôles	Version	Farben	Bedruckung
Type	Rastermaß	Polzahl	Version	Farben	Bedruckung

Altri colori a richiesta Autres couleurs sur demande	Other colours on demand Andere Farben bei Bedarf				

COB

Modulo componibile / Elements modulaires / Interlocking modules / Zusammensteckbare Blöcke

Poli / Pôles: 10, 16 / Poles / Polzahl: 1/2



10	10,16
500	
24	

0,2 ÷ 4 30 ÷ 12	0,2 ÷ 2,5 30 ÷ 12	0,2 ÷ 2,5 30 ÷ 12
6		
0,5	/	4
110		
PA - UL 94 VO		
M3		
	0,6 x 3,5	

V	A	mm²/AWG
750	24	0,5 ÷ 2,5
750	24	0,5 ÷ 2,5
300	16	24 ÷ 12

min 2 - max...
GR
D/A1

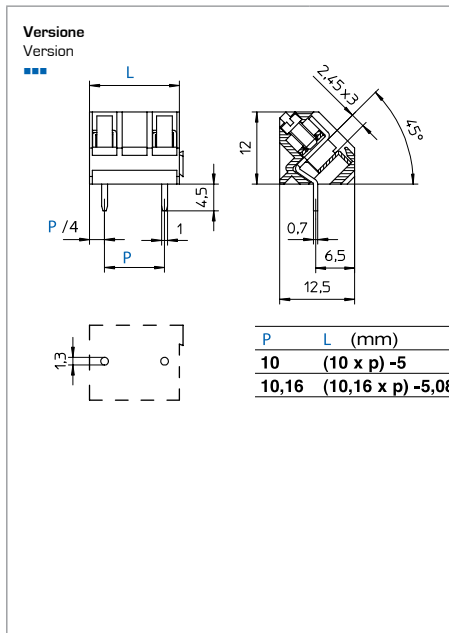

CII CII.SQ

Modulo componibile / Elements modulaires / Interlocking modules / Zusammensteckbare Blöcke

Poli / Pôles: 5, 8 / Poles / Polzahl: 2/3

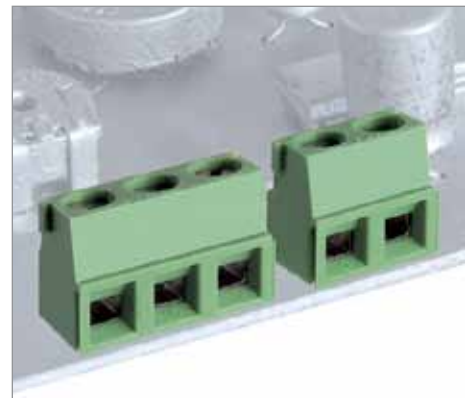

5	5,08
250	
14	

0,2 ÷ 2,5 30 ÷ 14	0,2 ÷ 1,5 30 ÷ 14	0,2 ÷ 1,5 30 ÷ 14
6		
0,5	/	4
110		
PA - UL 94 VO		
M3		
	0,6 x 3,5	

V	A	mm²/AWG
250	14	0,2 ÷ 1,5
250	14	0,2 ÷ 1,5
300	14	30 ÷ 14

min 2 - max...
VE
D/A1

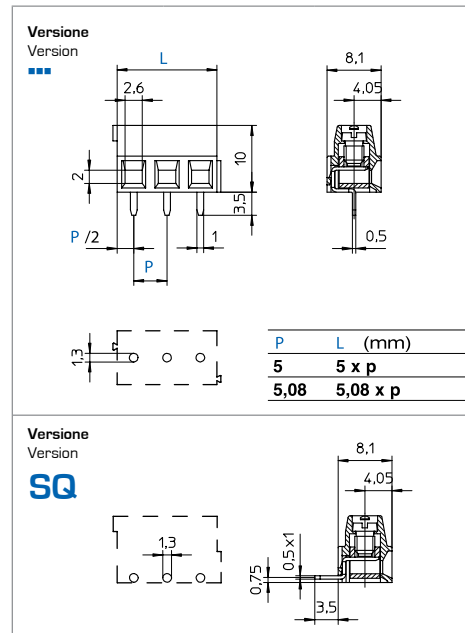

CII **CII..SQ**

Modulo componibile
Elements modulaires

Interlocking modules
Zusammensteckbare Blöcke

Poli
Pôles

Poles
Polzahl

1/2



10	10,16
630	
14	

0,2 ÷ 2,5 30 ÷ 14	0,2 ÷ 1,5 30 ÷ 14	0,2 ÷ 1,5 30 ÷ 14
6		
0,5	/	4
110		
PA - UL 94 VO		
M3		
⊕ 0,6 x 3,5		

V	A	mm ² /AWG
750	14	0,2 ÷ 1,5
750	14	0,2 ÷ 1,5
300	14	30 ÷ 14

min 2 - max...		
VE		
D/A1		

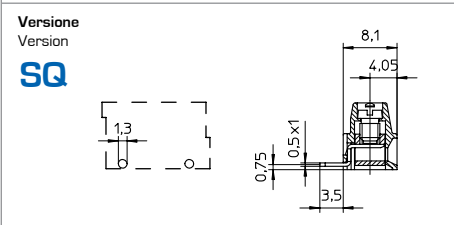
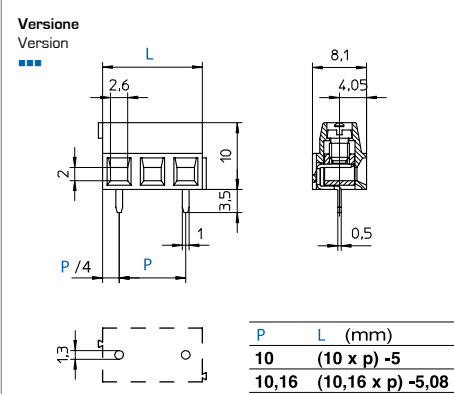

CIA **CIA..SQ**

Blocco unico
Monobloc

Single block
Einzelblock

Poli
Pôles

Poles
Polzahl

2/24

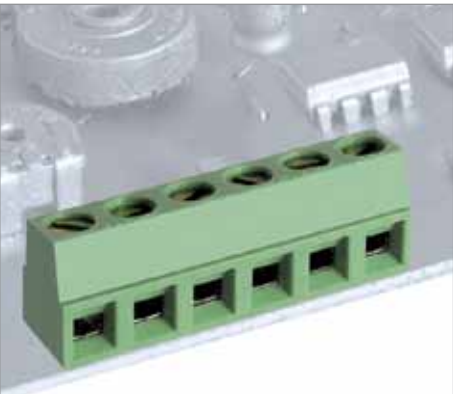

5	5,08
250	
14	

0,2 ÷ 2,5 30 ÷ 14	0,2 ÷ 1,5 30 ÷ 14	0,2 ÷ 1,5 30 ÷ 14
6		
0,5	/	4
110		
PA - UL 94 VO		
M3		
⊕ 0,6 x 3,5		

V	A	mm ² /AWG
250	14	0,2 ÷ 1,5
250	14	0,2 ÷ 1,5
300	14	30 ÷ 14

min 2 - max 24		
VE		
D/A1		

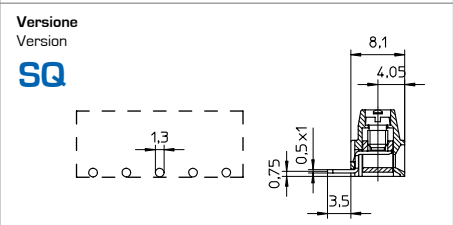
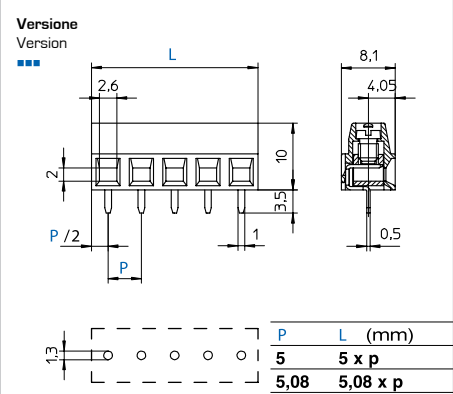

CIA **CIA..SQ**

Blocco unico
Monobloc

Single block
Einzelblock

Poli
Pôles

Poles
Polzahl

2/12



10	10,16
630	
14	

0,2 ÷ 2,5 30 ÷ 14	0,2 ÷ 1,5 30 ÷ 14	0,2 ÷ 1,5 30 ÷ 14
6		
0,5	/	4
110		
PA - UL 94 VO		
M3		
⊕ 0,6 x 3,5		

V	A	mm ² /AWG
750	14	0,2 ÷ 1,5
750	14	0,2 ÷ 1,5
300	14	30 ÷ 14

min 2 - max 12		
VE		
D/A1		

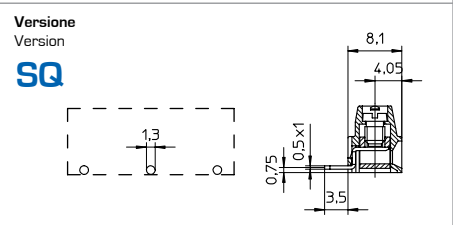
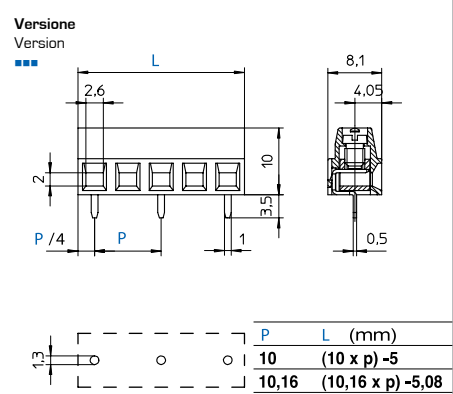

Morsetti per C.S. carrello

Terminal blocks for P.C.B. rising clamp

Blocs de jonction C.I. étrier remontant

Printklemmen Liftprinzip

Passo Pas	Pitch Rastermaß	mm
Tensione nominale Tension nominale	Rated Voltage Bemessungsspannung	V
Corrente nominale Intensité nominale	Rated Current Bemessungsstrom	A
Tipo cavi Type du conducteur	Types of cables Leitungstypen	
Sezione nominale Section nominale	Nominal cross section Nennquerschnitt	mm ² AWG
Lunghezza spelatura Longueur de dénudage	Stripping length Abisolierlänge	mm
Coppia di torsione Couple de serrage	Torque Drehmoment	Nm Lb-in
Temperatura Température	Temperature Temperatur	°C
Corpo isolante Corps isolant	Housing Isolierkörper	
Vite Imperdibile Vis Imperdable	Captive Screw Unverlierbare Schraube	

	IMQ	EN60998
	VDE	EN60998
	cUL	UL1059 + C22.2 n°158

Poli Pôles	Poles Polzahl	X
Colore standard Coloris standard	Standard colour Standardfarbe	Y
Altri dati Autres données	Other information Weitere Informationen	Pag Seite

Ordinazione Référence de commande	How to order Bestellschlüssel
CLL 5 / X	SQ Y N...
Tipo Type	Passo Pitch
Poli Poles	Versione Version
Colori Colors	Colori Couleurs
Numerazione Printing	Numerazione Marquage
Versione Version	Colori Farben
Colori Couleurs	Bedruckung Bedruckung

Altri colori a richiesta Autres couleurs sur demande	Other colours on demand Andere Farben bei Bedarf
VE GR NE AR BL RO	

CLL CLL..SQ

Modulo componibile Elements modulaires Interlocking modules Zusammensteckbare Blöcke

Poli Pôles Poles Polzahl 2/3

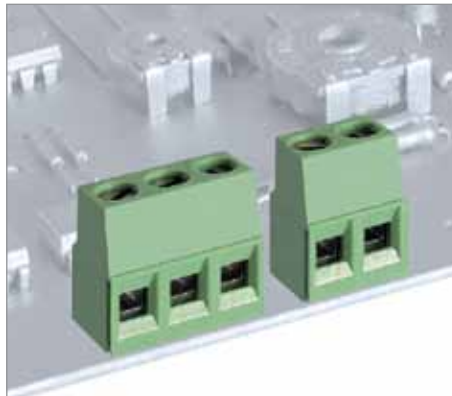

5	5,08	
250		
24		
0,2 ÷ 4 30 ÷ 12	0,2 ÷ 2,5 30 ÷ 12	0,2 ÷ 2,5 30 ÷ 12
6		
0,5	/	4
110		
PA - UL 94 VO		
M3		
	0,6 x 3,5	

V	A	mm²/AWG
250	24	0,5 ÷ 2,5
250	24	0,5 ÷ 2,5
300	14	30 ÷ 12

min 2 - max...
VE
D/A1

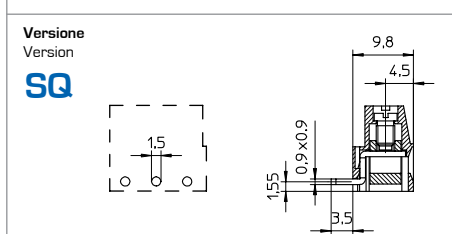
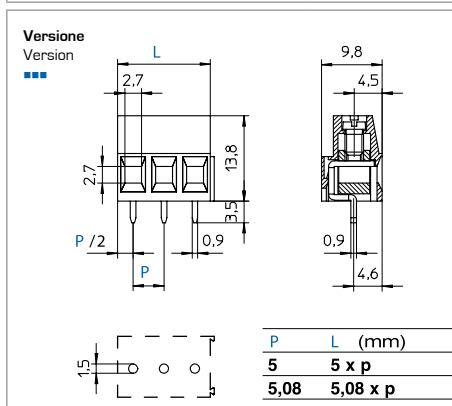

CLL CLL..SQ

Modulo componibile Elements modulaires Interlocking modules Zusammensteckbare Blöcke

Poli Pôles Poles Polzahl 2/3



7,5	7,62	
500		
24		
0,2 ÷ 4 30 ÷ 12	0,2 ÷ 2,5 30 ÷ 12	0,2 ÷ 2,5 30 ÷ 12
6		
0,5	/	4
110		
PA - UL 94 VO		
M3		
	0,6 x 3,5	

V	A	mm²/AWG
750	24	0,5 ÷ 2,5
750	24	0,5 ÷ 2,5
300	14	30 ÷ 12

min 2 - max...
VE
D/A1

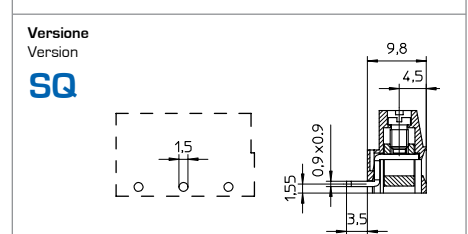
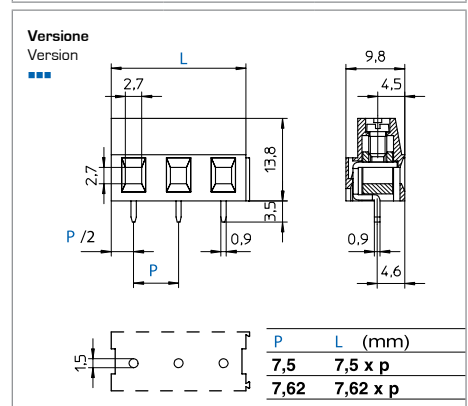

CLL | **CLL..SQ**

Modulo componibile
Elements modulaires

Interlocking modules
Zusammensteckbare Blöcke

Poli
Pôles

Poles
Polzahl

1/2

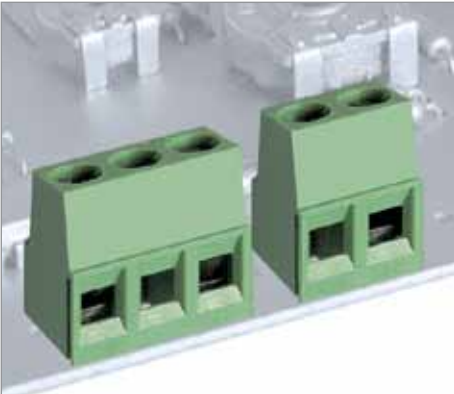

10	10,16
630	
24	

0,2 ÷ 4 30 ÷ 12	0,2 ÷ 2,5 30 ÷ 12	0,2 ÷ 2,5 30 ÷ 12
6		
0,5	/	4
110		
PA - UL 94 VO		
M3		
	0,6 x 3,5	

V	A	mm ² /AWG
750	24	0,5 ÷ 2,5
750	24	0,5 ÷ 2,5
300	14	30 ÷ 12

min 2 - max...		
D/A1		

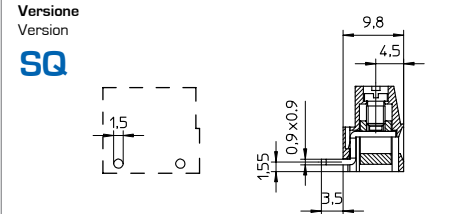
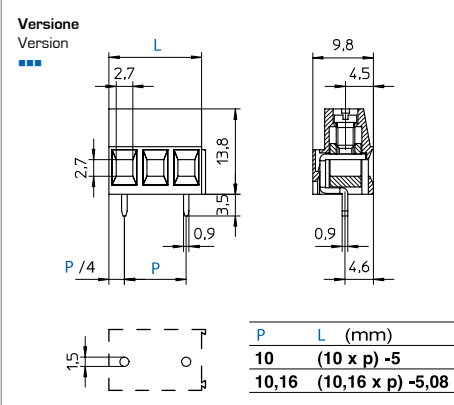

CLA | **CLA..SQ**

Blocco unico
Monobloc

Single block
Einzelblock

Poli
Pôles

Poles
Polzahl

2/24



5	5,08
250	
24	

0,2 ÷ 4 30 ÷ 12	0,2 ÷ 2,5 30 ÷ 12	0,2 ÷ 2,5 30 ÷ 12
6		
0,5	/	4
110		
PA - UL 94 VO		
M3		
	0,6 x 3,5	

V	A	mm ² /AWG
250	24	0,5 ÷ 2,5
250	24	0,5 ÷ 2,5
300	14	30 ÷ 12

min 2 - max 24		
D/A1		

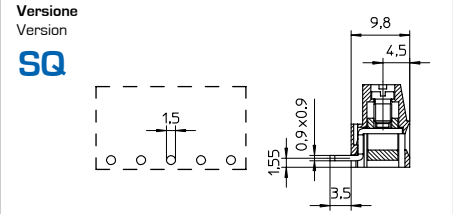
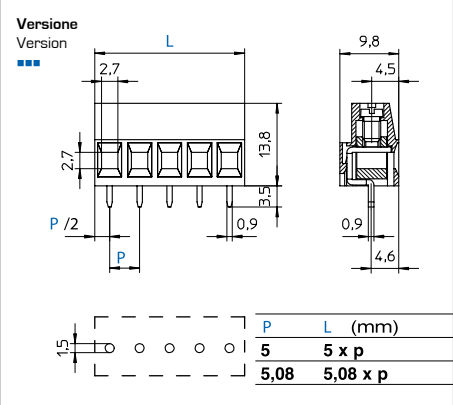

CLA | **CLA..SQ**

Blocco unico
Monobloc

Single block
Einzelblock

Poli
Pôles

Poles
Polzahl

2/12



7,5	
500	
24	

0,2 ÷ 4 30 ÷ 12	0,2 ÷ 2,5 30 ÷ 12	0,2 ÷ 2,5 30 ÷ 12
6		
0,5	/	4
110		
PA - UL 94 VO		
M3		
	0,6 x 3,5	

V	A	mm ² /AWG
750	24	0,5 ÷ 2,5
750	24	0,5 ÷ 2,5
300	14	30 ÷ 12

min 2 - max 12		
D/A1		

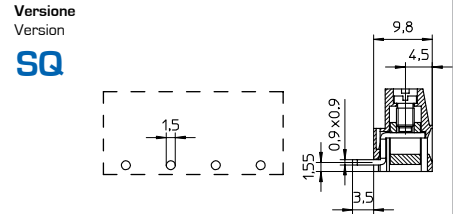
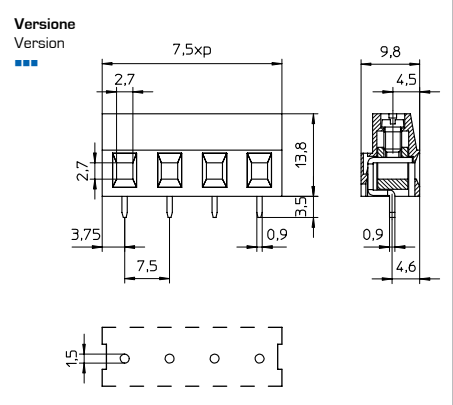

Morsetti per C.S. carrello

Terminal blocks for P.C.B. rising clamp

Blocs de jonction C.I. étrier remontant

Printklemmen Liftprinzip

CLA CLA..SQ

Blocco unico Monobloc Single block Einzelblock

Poli Poles 2/12



10	10,16
630	
24	

0,2 ÷ 4 30 ÷ 12	0,2 ÷ 2,5 30 ÷ 12	0,2 ÷ 2,5 30 ÷ 12
6		
0,5	/	4
110		
PA - UL 94 VO		
M3		
	0,6 x 3,5	

V	A	mm²/AWG
750	24	0,5 ÷ 2,5
750	24	0,5 ÷ 2,5
300	14	30 ÷ 12

min 2 - max 12
VE
D/A1

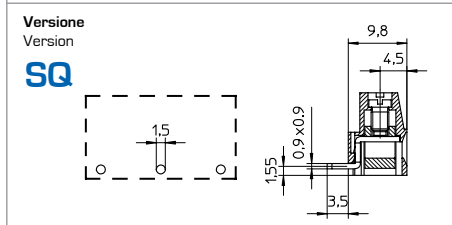
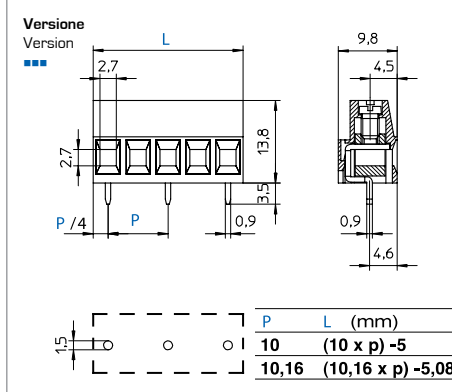

MRT4 MRT4..SQV01

Modulo componibile Elements modulaires Interlocking modules Zusammensteckbare Blöcke

Poli Poles 2/3

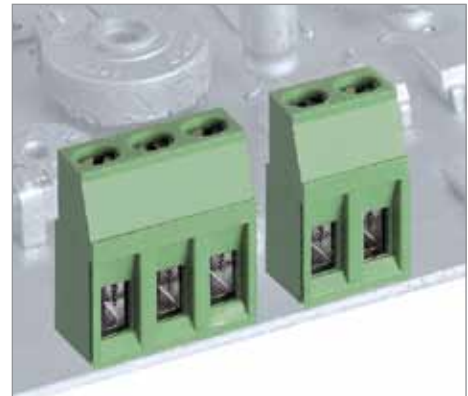

5
250
24

0,2 ÷ 4 (x 2) 30 ÷ 12	0,2 ÷ 2,5 (x 2) 30 ÷ 12	0,2 ÷ 2,5 (x 2) 30 ÷ 12
6		
0,5	/	5
110		
PA - UL 94 VO		
M3		
	0,6 x 3,5	

V	A	mm²/AWG
250	24	0,5 ÷ 2,5 (x 2)
250	24	0,5 ÷ 2,5 (x 2)
300	16	24 ÷ 12

min 2 - max...
VE
D/A1

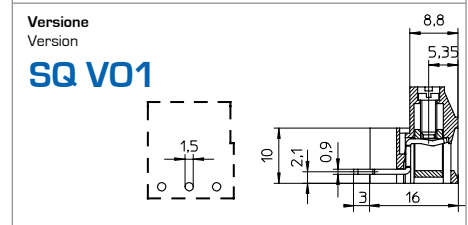
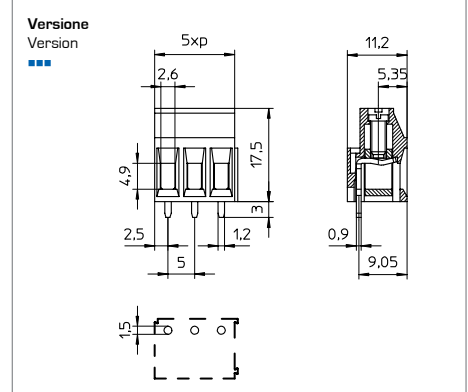

Passo Pas	Pitch Rastermaß	mm
Tensione nominale Tension nominale	Rated Voltage Bemessungsspannung	V
Corrente nominale Intensité nominale	Rated Current Bemessungsstrom	A
Tipo cavi Type du conducteur	Types of cables Leitungstypen	
Sezione nominale Section nominale	Nominal cross section Nennquerschnitt	mm² AWG
Lunghezza spelatura Longueur de dénudage	Stripping length Abisolierlänge	mm
Coppia di torsione Couple de serrage	Torque Drehmoment	Nm Lb-in
Temperatura Temperature	Temperature Temperatur	°C
Corpo isolante Corps isolant	Housing Isolierkörper	
Vite Imperdibile Vis Imperdable	Captive Screw Unverlierbare Schraube	

	IMQ	EN60998
	VDE	EN60998
	cUL	UL1059 + C22.2 n°158

Poli Pôles	Poles Polzahl	X
Colore standard Coloris standard	Standard colour Standardfarbe	Y
Altri dati Autres données	Other information Weitere Informationen	Pag Seite

Ordinazione Référence de commande **How to order Bestellschlüssel**

CLA 10 / X **SQ Y N...**

Tipo Type	Passo Pitch	Poli Poles	Versione Version	Colori Colors	Numerazione Printing
Type	Pas	Pôles	Version	Couleurs	Marquage
Typ	Rastermaß	Polzahl	Version	Farben	Bedruckung

Altri colori a richiesta Autres couleurs sur demande **Other colours on demand Andere Farben bei Bedarf**

VE GR NE AR BL RO

MRT4

MRT4..SQV01

Modulo componibile
Elements modulaires

Interlocking modules
Zusammensteckbare Blöcke

Poli Póles 1/2



10
630
24

0,2 ÷ 4 (x 2) 30 ÷ 12	0,2 ÷ 2,5 (x 2) 30 ÷ 12	0,2 ÷ 2,5 (x 2) 30 ÷ 12
6		
0,5 / 5		
110		
PA - UL 94 VO		
M3		
0,6 x 3,5		

V	A	mm ² /AWG
750	24	0,5 ÷ 2,5 (x 2)
750	24	0,5 ÷ 2,5 (x 2)
300	16	24 ÷ 12

min 2 - max...
VE
D/A1

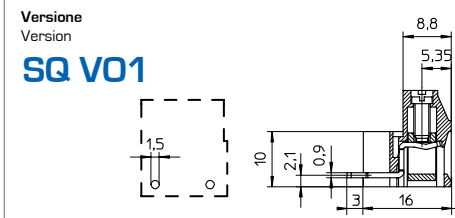
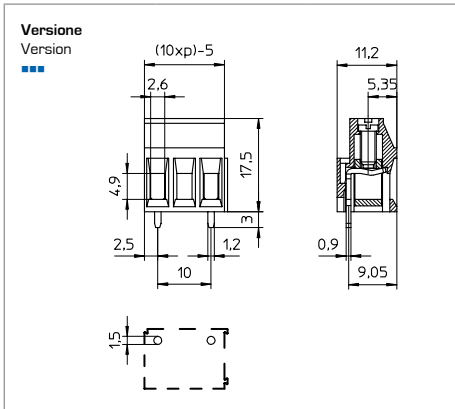

CUU

CUU..SQ

Blocco unico
Monobloc

Single block
Einzelblock

Poli Póles 2/36



5
250
22

0,2 ÷ 4 30 ÷ 12	0,2 ÷ 2,5 30 ÷ 12	0,2 ÷ 2,5 30 ÷ 12
6		
0,5 / 4		
85		
PC - UL 94 VO		
M2,5		
0,6 x 3,5		

V	A	mm ² /AWG
450	22	0,5 ÷ 2,5
450	22	0,5 ÷ 2,5
300	16	24 ÷ 12

min 2 - max 36
GR
D/A1

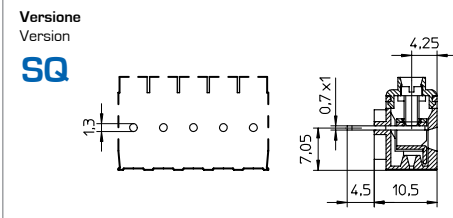
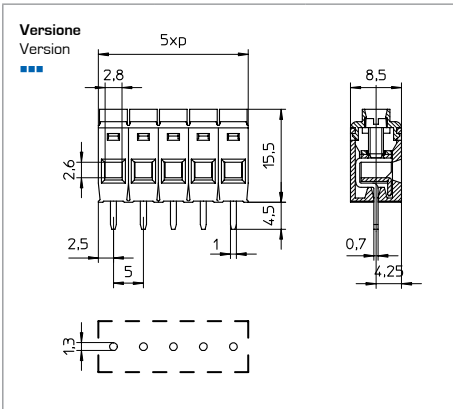

CUU

CUU..SQ

Blocco unico
Monobloc

Single block
Einzelblock

Poli Póles 2/18



10
500
22

0,2 ÷ 4 30 ÷ 12	0,2 ÷ 2,5 30 ÷ 12	0,2 ÷ 2,5 30 ÷ 12
6		
0,5 / 4		
85		
PC - UL 94 VO		
M2,5		
0,6 x 3,5		

V	A	mm ² /AWG
750	22	0,5 ÷ 2,5
750	22	0,5 ÷ 2,5
300	16	24 ÷ 12

min 2 - max 18
GR
D/A1

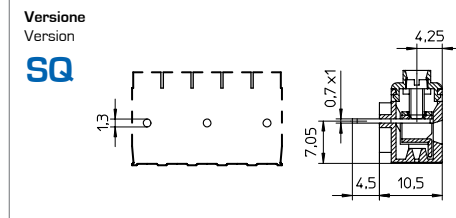
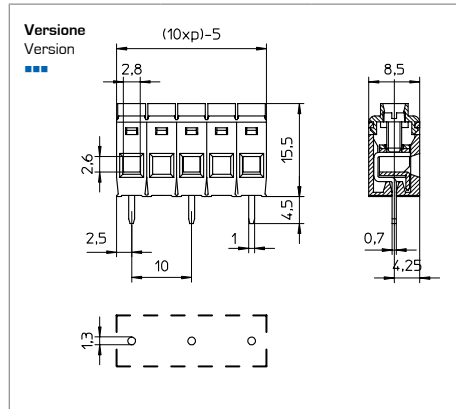

Morsetti per C.S. carrello

Terminal blocks for P.C.B. rising clamp

Blocs de jonction C.I. étrier remontant

Printklemmen Liftprinzip

Passo Pas	Pitch Rastermaß	mm
Tensione nominale Tension nominale	Rated Voltage Bemessungsspannung	V
Corrente nominale Intensité nominale	Rated Current Bemessungsstrom	A
Tipo cavi Type du conducteur	Types of cables Leitungstypen	
Sezione nominale Section nominale	Nominal cross section Nennquerschnitt	mm ² AWG
Lunghezza spelatura Longueur de dénudage	Stripping length Abisolierlänge	mm
Coppia di torsione Couple de serrage	Torque Drehmoment	Nm Lb-in
Temperatura Température	Temperature Temperatur	°C
Corpo isolante Corps isolant	Housing Isolierkörper	
Vite Imperdibile Vis Imperdable	Captive Screw Unverlierbare Schraube	

	IMQ	EN60998
	VDE	EN60998
	cUL	UL1059 + C22.2 n°158

Poli Pôles	Poles Polzahl	X
Colore standard Coloris standard	Standard colour Standardfarbe	Y
Altri dati Autres données	Other information Weitere Informationen	Pag Seite

Ordinazione Référence de commande	How to order Bestellschlüssel				
MRT5 P5 / X	SQ Y N...				
Tipo Type	Passo Pitch	Poli Poles	Versione Version	Colori Colors	Numerazione Printing
Type	Pas	Pôles	Version	Couleurs	Marquage
Typ	Rastermaß	Polzahl	Version	Farben	Bedruckung

Altri colori a richiesta Autres couleurs sur demande	Other colours on demand Andere Farben bei Bedarf				

MRT5 MRT5..SQ

Modulo componibile Elements modulaires Interlocking modules Zusammensteckbare Blöcke

Poli Pôles Poles Polzahl 2/3



5	5,08	
320		
24		
0,2 ÷ 4 30 ÷ 12	0,2 ÷ 2,5 30 ÷ 12	0,2 ÷ 2,5 30 ÷ 12
6		
0,5	/	5
110		
PA - UL 94 VO		
M3		
0,6 x 3,5		

V	A	mm²/AWG
450	24	0,5 ÷ 2,5
450	24	0,5 ÷ 2,5
300	16	24 ÷ 12

min 2 - max...
VE
D/A1

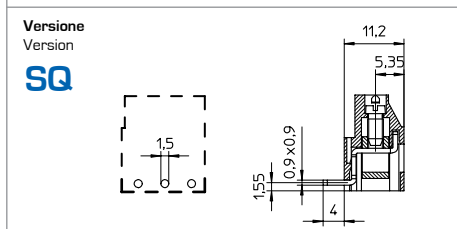
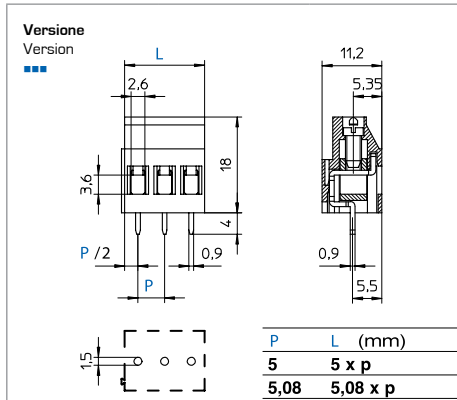

MRT5..DP

Modulo componibile Elements modulaires Interlocking modules Zusammensteckbare Blöcke

Poli Pôles Poles Polzahl 2/3



5	5,08	
320		
24		
0,2 ÷ 4 30 ÷ 12	0,2 ÷ 2,5 30 ÷ 12	0,2 ÷ 2,5 30 ÷ 12
6		
0,5	/	5
110		
PA - UL 94 VO		
M3		
0,6 x 3,5		

V	A	mm²/AWG
450	24	0,5 ÷ 2,5
450	24	0,5 ÷ 2,5
300	16	24 ÷ 12

min 2 - max...
VE
D/A1

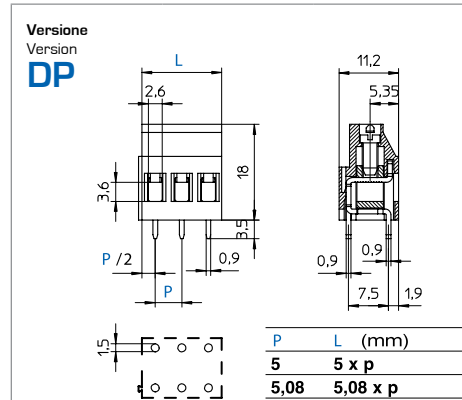

MRT5

MRT5..SQ

Modulo componibile
Elements modulaires

Interlocking modules
Zusammensteckbare Blöcke

Poli Pôles 2/3



7,5	7,62
500	
24	

0,2 ÷ 4 30 ÷ 12	0,2 ÷ 2,5 30 ÷ 12	0,2 ÷ 2,5 30 ÷ 12

6

0,5 / 5

110

PA - UL 94 VO

M3

0,6 x 3,5

V	A	mm ² /AWG
750	24	0,5 ÷ 2,5
750	24	0,5 ÷ 2,5
300	16	24 ÷ 12

min 2 - max...		
D/A1		

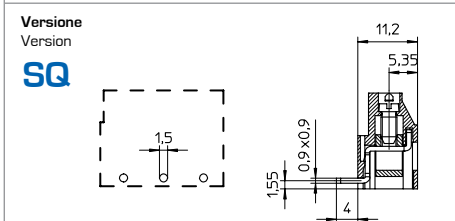
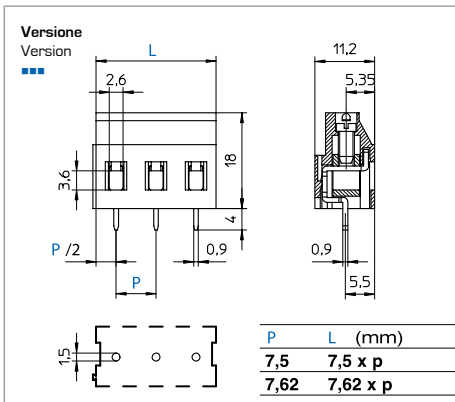

MRT5..DP

Modulo componibile
Elements modulaires

Interlocking modules
Zusammensteckbare Blöcke

Poli Pôles 2/3



7,5	7,62
500	
24	

0,2 ÷ 4 30 ÷ 12	0,2 ÷ 2,5 30 ÷ 12	0,2 ÷ 2,5 30 ÷ 12

6

0,5 / 5

110

PA - UL 94 VO

M3

0,6 x 3,5

V	A	mm ² /AWG
750	24	0,5 ÷ 2,5
750	24	0,5 ÷ 2,5
300	16	24 ÷ 12

min 2 - max...		
D/A1		

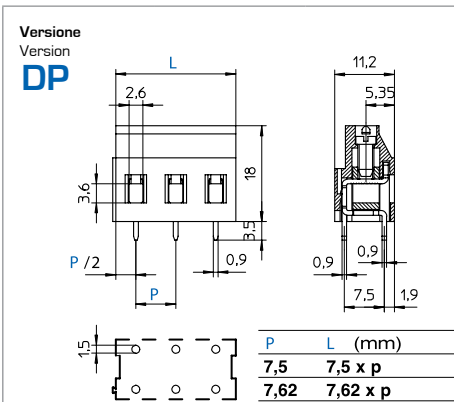

MRT5

MRT5..SQ

Modulo componibile
Elements modulaires

Interlocking modules
Zusammensteckbare Blöcke

Poli Pôles 1/2



10	10,16
630	
24	

0,2 ÷ 4 30 ÷ 12	0,2 ÷ 2,5 30 ÷ 12	0,2 ÷ 2,5 30 ÷ 12

6

0,5 / 5

110

PA - UL 94 VO

M3

0,6 x 3,5

V	A	mm ² /AWG
750	24	0,5 ÷ 2,5
750	24	0,5 ÷ 2,5
300	16	24 ÷ 12

min 2 - max...		
D/A1		

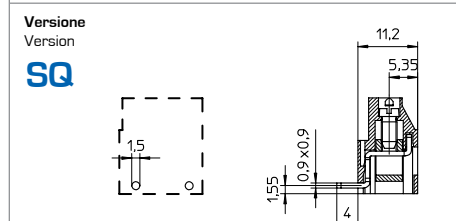
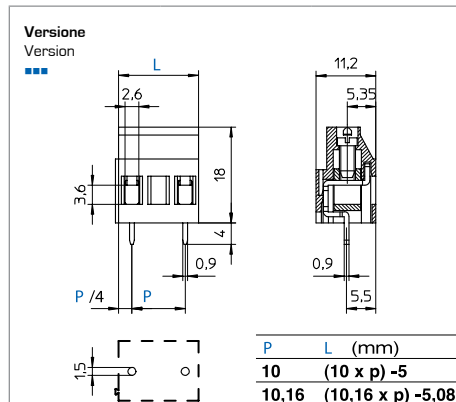

Morsetti per C.S. carrello

Terminal blocks for P.C.B. rising clamp

Blocs de jonction C.I. étrier remontant

Printklemmen Liftprinzip

MRT5..DP

Modulo componibile / Elements modulaires / Interlocking modules / Zusammensteckbare Blöcke

Poli / Poles: 1/2

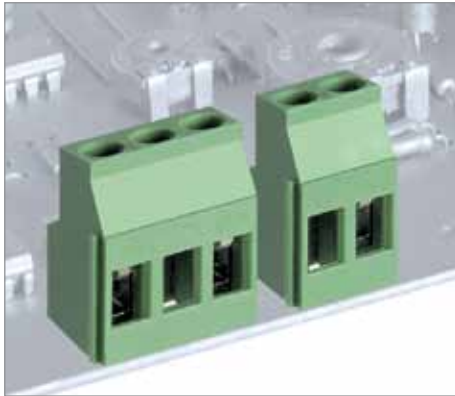

10	10,16
630	
24	

0,2 ÷ 4 30 ÷ 12	0,2 ÷ 2,5 30 ÷ 12	0,2 ÷ 2,5 30 ÷ 12
6		
0,5	/	5
110		
PA - UL 94 VO		
M3		
0,6 x 3,5		

V	A	mm ² /AWG
750	24	0,5 ÷ 2,5
750	24	0,5 ÷ 2,5
300	16	24 ÷ 12

min 2 - max...		
VE		
D/A1		

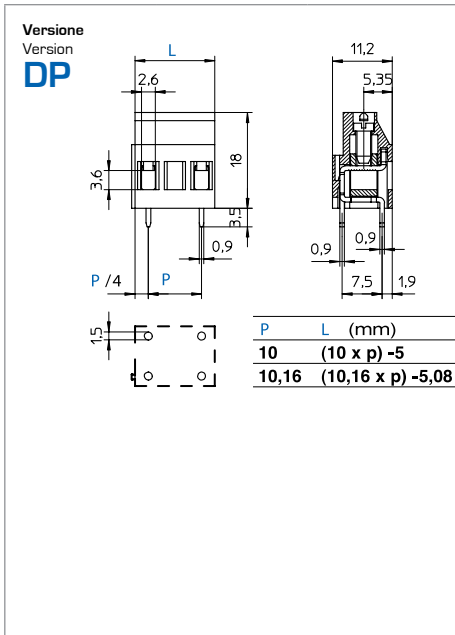

MRT15 MRT15..SQ

Blocco unico / Monobloc / Single block / Einzelblock

Poli / Poles: 2/24



5	5,08
320	
24	

0,2 ÷ 4 30 ÷ 12	0,2 ÷ 2,5 30 ÷ 12	0,2 ÷ 2,5 30 ÷ 12
6		
0,5	/	5
110		
PA - UL 94 VO		
M3		
0,6 x 3,5		

V	A	mm ² /AWG
450	24	0,5 ÷ 2,5
450	24	0,5 ÷ 2,5
300	16	30 ÷ 12

min 2 - max 24		
VE		
D/A1		

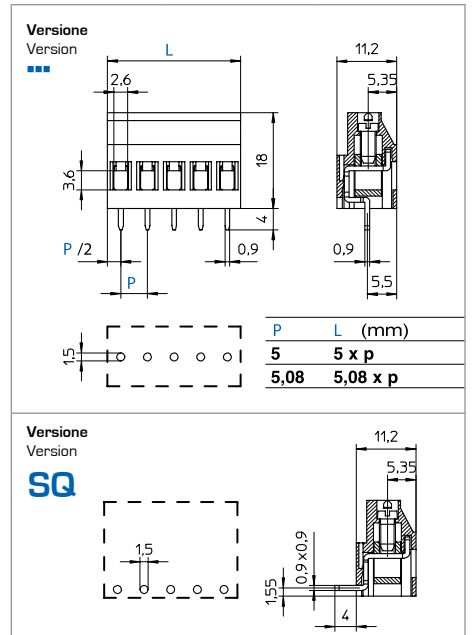

Passo Pas	Pitch Rastermaß	mm
Tensione nominale Tension nominale	Rated Voltage Bemessungsspannung	V
Corrente nominale Intensité nominale	Rated Current Bemessungsstrom	A

Tipo cavi Type du conducteur	Types of cables Leitungstypen	
Sezione nominale Section nominale	Nominal cross section Nennquerschnitt	mm ² AWG
Lunghezza spelatura Longueur de dénudage	Stripping length Abisolierlänge	mm
Coppia di torsione Couple de serrage	Torque Drehmoment	Nm Lb-in
Temperatura Température	Temperature Temperatur	°C
Corpo isolante Corps isolant	Housing Isolierkörper	
Vite Imperdibile Vis Imperdable	Captive Screw Unverlierbare Schraube	

	IMQ	EN60998
	VDE	EN60998
	cUL	UL1059 + C22.2 n°158

Poli Pôles	Poles Polzahl	X
Colore standard Coloris standard	Standard colour Standardfarbe	Y
Altri dati Autres données	Other information Weitere Informationen	Pag Seite

Ordinazione Référence de commande	How to order Bestellschlüssel
MRT5 P10 / X	DP Y N...
Tipo Type	Passo Pitch
Poli Poles	Versione Version
Colori Couleurs	Colori Couleurs
Numerazione Marquage	Numerazione Marquage

Altri colori a richiesta Autres couleurs sur demande	Other colours on demand Andere Farben bei Bedarf
VE GR NE AR BL RO	

MRT15..DP

Blocco unico / Monobloc Single block / Einzelblock

Poli / Póles Poles / Polzahl 2/24



5	5,08
320	
24	

0,2 ÷ 4 30 ÷ 12	0,2 ÷ 2,5 30 ÷ 12	0,2 ÷ 2,5 30 ÷ 12
6		
0,5	/	5
110		
PA - UL 94 VO		
M3		
⊕ 0,6 x 3,5		

V	A	mm ² /AWG
450	24	0,5 ÷ 2,5
450	24	0,5 ÷ 2,5
300	16	30 ÷ 12

min 2 - max 24	
VE	
D/A1	

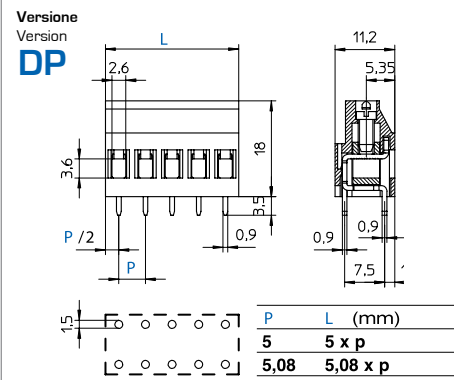

MRT15 MRT15..SQ

Blocco unico / Monobloc Single block / Einzelblock

Poli / Póles Poles / Polzahl 2/12



10	10,16
630	
24	

0,2 ÷ 4 30 ÷ 12	0,2 ÷ 2,5 30 ÷ 12	0,2 ÷ 2,5 30 ÷ 12
6		
0,5	/	5
110		
PA - UL 94 VO		
M3		
⊕ 0,6 x 3,5		

V	A	mm ² /AWG
750	24	0,5 ÷ 2,5
750	24	0,5 ÷ 2,5
300	16	30 ÷ 12

min 2 - max 12	
VE	
D/A1	

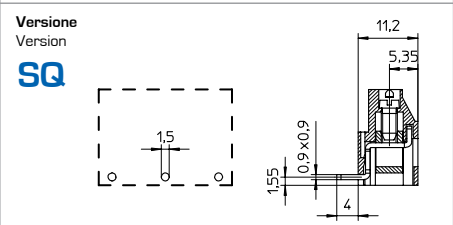
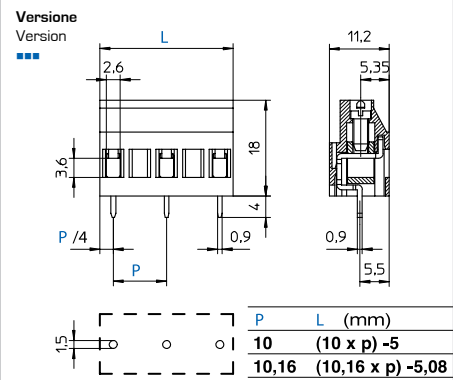

MRT15..DP

Blocco unico / Monobloc Single block / Einzelblock

Poli / Póles Poles / Polzahl 2/12



10	10,16
630	
24	

0,2 ÷ 4 30 ÷ 12	0,2 ÷ 2,5 30 ÷ 12	0,2 ÷ 2,5 30 ÷ 12
6		
0,5	/	5
110		
PA - UL 94 VO		
M3		
⊕ 0,6 x 3,5		

V	A	mm ² /AWG
750	24	0,5 ÷ 2,5
750	24	0,5 ÷ 2,5
300	16	30 ÷ 12

min 2 - max 12	
VE	
D/A1	

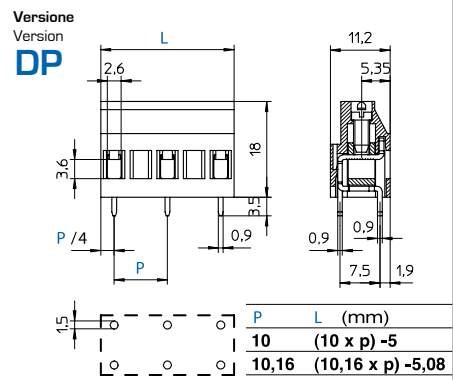

Morsetti per C.S. carrello

Terminal blocks for P.C.B. rising clamp

Blocs de jonction C.I. étrier remontant

Printklemmen Liftprinzip

Passo Pas	Pitch Rastermaß	mm
Tensione nominale Tension nominale	Rated Voltage Bemessungsspannung	V
Corrente nominale Intensité nominale	Rated Current Bemessungsstrom	A

Tipo cavi Type du conducteur	Types of cables Leitungstypen	
Sezione nominale Section nominale	Nominal cross section Nennquerschnitt	mm ² AWG
Lunghezza spelatura Longueur de dénudage	Stripping length Abisolierlänge	mm
Coppia di torsione Couple de serrage	Torque Drehmoment	Nm Lb-in
Temperatura Température	Temperature Temperatur	°C
Corpo isolante Corps isolant	Housing Isolierkörper	
Vite Imperdibile Vis Imperdable	Captive Screw Unverlierbare Schraube	

	IMQ	EN60998
	VDE	EN60998
	cUL	UL1059 + C22.2 n°158

Poli Pôles	Poles Polzahl	X
Colore standard Coloris standard	Standard colour Standardfarbe	Y
Altri dati Autres données	Other information Weitere Informationen	Pag Seite

Ordinazione Référence de commande	How to order Bestellschlüssel
MRT6 P5 / X	... Y N...
Tipo	Versione
Type	Version
Type	Version
Typ	Version

Altri colori a richiesta Autres couleurs sur demande	Other colours on demand Andere Farben bei Bedarf

MRT6

Modulo componibile / Elements modulaires / Interlocking modules / Zusammensteckbare Blöcke

Poli / Poles: 2/3



5
320
24

0,2 ÷ 4 30 ÷ 12	0,2 ÷ 2,5 30 ÷ 12	0,2 ÷ 2,5 30 ÷ 12
6		
0,5	/	5
110		
PA - UL 94 VO		
M3		
0,6 x 3,5		

V	A	mm²/AWG
450	24	0,5 ÷ 2,5
450	24	0,5 ÷ 2,5
300	16	24 ÷ 12

min 2 - max...
VE
D/A1

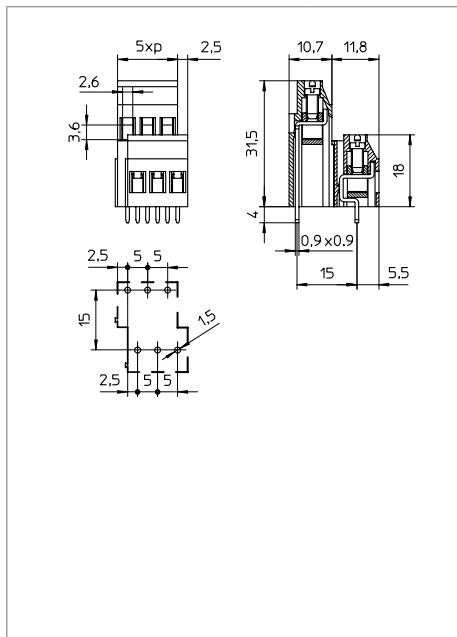

MRT6

Modulo componibile / Elements modulaires / Interlocking modules / Zusammensteckbare Blöcke

Poli / Poles: 1/2



10
630
24

0,2 ÷ 4 30 ÷ 12	0,2 ÷ 2,5 30 ÷ 12	0,2 ÷ 2,5 30 ÷ 12
6		
0,5	/	5
110		
PA - UL 94 VO		
M3		
0,6 x 3,5		

V	A	mm²/AWG
750	24	0,5 ÷ 2,5
750	24	0,5 ÷ 2,5
300	16	24 ÷ 12

min 2 - max...
VE
D/A1

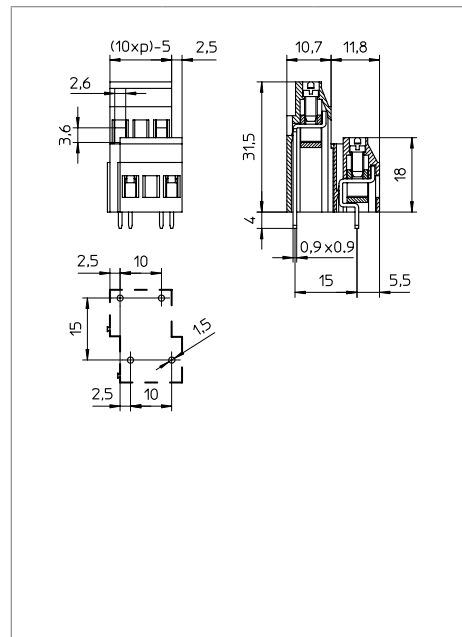

MRT18

MRT18..VO1

Modulo componibile
Elements modulaires

Interlocking modules
Zusammensteckbare Blöcke

Poli Poles 2/3 (5,08)
Pôles Polzahl 1/2 (10,16)



5,08	10,16
320	630
20	

0,2 ÷ 4 30 ÷ 12	0,2 ÷ 2,5 30 ÷ 12	0,2 ÷ 2,5 30 ÷ 12
6		
0,5	/	5
110		
PA - UL 94 VO		
M3		
⊕ 0,6 x 3,5		

V	A	mm ² /AWG
450 750 (5,08) (10,16)	20	0,5 ÷ 2,5
450 750 (5,08) (10,16)	20	0,5 ÷ 2,5
300 (5,08 and 10,16)	20	30 ÷ 12

min 2 - max...
VE
D/A1

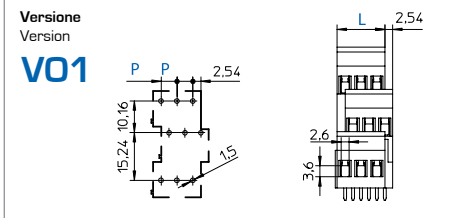
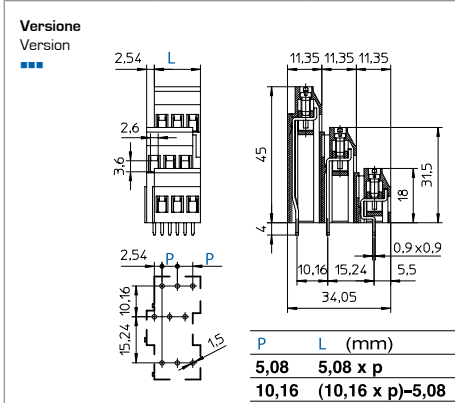

MRT18..VO4

MRT18..VO5

Modulo componibile
Elements modulaires

Interlocking modules
Zusammensteckbare Blöcke

Poli Poles 2/3 (5,08)
Pôles Polzahl 1/2 (10,16)



5,08	10,16
320	630
20	

0,2 ÷ 4 30 ÷ 12	0,2 ÷ 2,5 30 ÷ 12	0,2 ÷ 2,5 30 ÷ 12
6		
0,5	/	5
110		
PA - UL 94 VO		
M3		
⊕ 0,6 x 3,5		

V	A	mm ² /AWG
450 750 (5,08) (10,16)	20	0,5 ÷ 2,5
450 750 (5,08) (10,16)	20	0,5 ÷ 2,5
300 (5,08 and 10,16)	20	30 ÷ 12

min 2 - max...
VE
D/A1

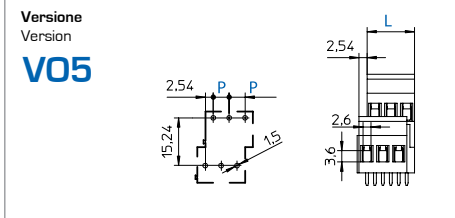
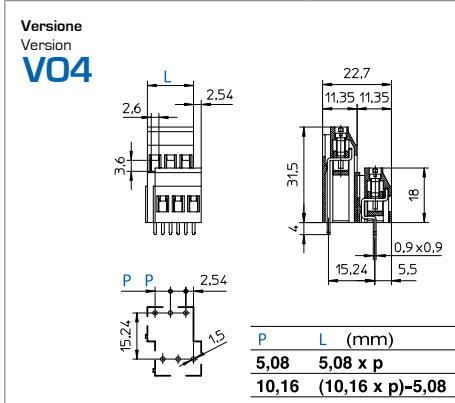

MRT18..VO2

MRT18..VO3

Modulo componibile
Elements modulaires

Interlocking modules
Zusammensteckbare Blöcke

Poli Poles 2/3 (5,08)
Pôles Polzahl 1/2 (10,16)



5,08	10,16
320	630
20	

0,2 ÷ 4 30 ÷ 12	0,2 ÷ 2,5 30 ÷ 12	0,2 ÷ 2,5 30 ÷ 12
6		
0,5	/	5
110		
PA - UL 94 VO		
M3		
⊕ 0,6 x 3,5		

V	A	mm ² /AWG
450 750 (5,08) (10,16)	20	0,5 ÷ 2,5
450 750 (5,08) (10,16)	20	0,5 ÷ 2,5
300 (5,08 and 10,16)	20	30 ÷ 12

min 2 - max...
VE
D/A1

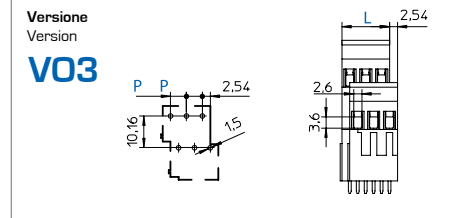
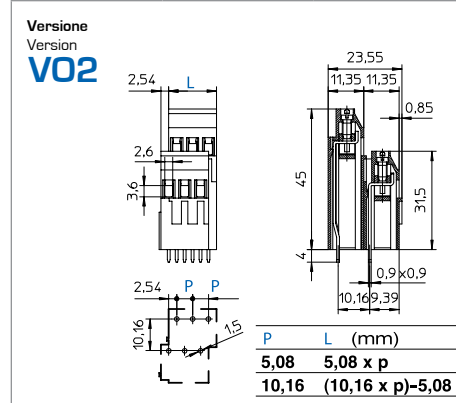

Morsetti per C.S. carrello

Terminal blocks for P.C.B. rising clamp

Blocs de jonction C.I. étrier remontant

Printklemmen Liftprinzip

Passo Pas	Pitch Rastermaß	mm
Tensione nominale Tension nominale	Rated Voltage Bemessungsspannung	V
Corrente nominale Intensité nominale	Rated Current Bemessungsstrom	A

Tipo cavi Type du conducteur	Types of cables Leitungstypen	
Sezione nominale Section nominale	Nominal cross section Nennquerschnitt	mm ² AWG
Lunghezza spelatura Longueur de dénudage	Stripping length Abisolierlänge	mm
Coppia di torsione Couple de serrage	Torque Drehmoment	Nm Lb-in
Temperatura Température	Temperature Temperatur	°C
Corpo isolante Corps isolant	Housing Isolierkörper	
Vite Imperdibile Vis Imperdable	Captive Screw Unverlierbare Schraube	

	IMQ	EN60998
	VDE	EN60998
	cUL	UL1059 + C22.2 n°158

Poli Pôles	Poles Polzahl	X
Colore standard Coloris standard	Standard colour Standardfarbe	Y
Altri dati Autres données	Other information Weitere Informationen	Pag Seite

Ordinazione Référence de commande	How to order Bestellschlüssel				
MRT18 P5,08 / X	V06 Y N...				
Tipo Type	Passo Pitch	Poli Poles	Versione Version	Colori Colors	Numerazione Printing
Type	Pas	Pôles	Version	Couleurs	Marquage
Typ	Rastermaß	Polzahl	Version	Farben	Bedruckung

Altri colori a richiesta Autres couleurs sur demande	Other colours on demand Andere Farben bei Bedarf				

MRT18..V06 MRT18..V07 MRT18..V08

Modulo componibile Elements modulaires Interlocking modules Zusammensteckbare Blöcke

Poli Poles	Poles Polzahl	2/3 [5,08] 1/2 [10,16]
----------------------	-------------------------	---

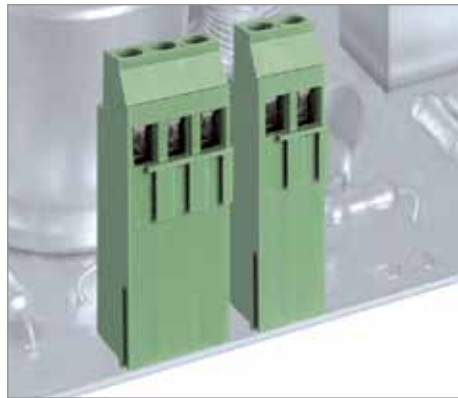

5,08	10,16
320	630
20	

0,2 ÷ 4 30 ÷ 12	0,2 ÷ 2,5 30 ÷ 12	0,2 ÷ 2,5 30 ÷ 12
6		
0,5	/	5
110		
PA - UL 94 VO		
M3		
	0,6 x 3,5	

V	A	mm²/AWG
450 [5,08]	750 [10,16]	20
450 [5,08]	750 [10,16]	20
300 [5,08 and 10,16]	20	30 ÷ 12

min 2 - max...
VE
D/A1

Versione
Version
V06

P	L (mm)
5,08	5,08 x p
10,16	(10,16 x p)-5,08

Versione
Version
V07

Versione
Version
V08

MRT20

Modulo componibile Elements modulaires Interlocking modules Zusammensteckbare Blöcke

Poli Pôles	Poles Polzahl	2/3
----------------------	-------------------------	------------

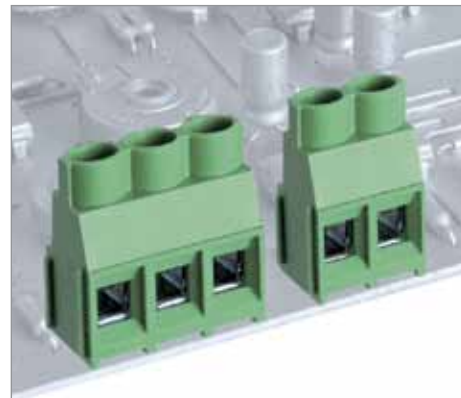

6,35	9,52
400	630
32	

0,2 ÷ 6 30 ÷ 10	0,2 ÷ 6 30 ÷ 10	0,2 ÷ 6 30 ÷ 10
8		
0,5	/	5
110		
PA - UL 94 VO		
M3		
	0,8 x 4,5	and
		PZ1

V	A	mm²/AWG
450 [6,35]	750 [9,52]	32
450 [6,35]	750 [9,52]	32
300 [6,35 and 9,52]	24	30 ÷ 10

min 2 - max...
VE
D/A1

Versione
Version
V06

P	L (mm)
6,35	6,35 x p
9,52	9,52 x p

MRT19

Blocco unico
Monobloc

Single block
Einzelblock

Poli Pôles 2



8
500
24

0,2 ÷ 6 30 ÷ 10	0,2 ÷ 4 30 ÷ 10	0,2 ÷ 4 30 ÷ 10

8
0,5 / 5

110

PA - UL 94 VO

M3

⊖ 0,6 x 3,5 and ⊕ PZ1

V	A	mm ² /AWG
750	24	0,5 ÷ 4
750	24	0,5 ÷ 4
300	24	30 ÷ 10

2
GR
D/A1

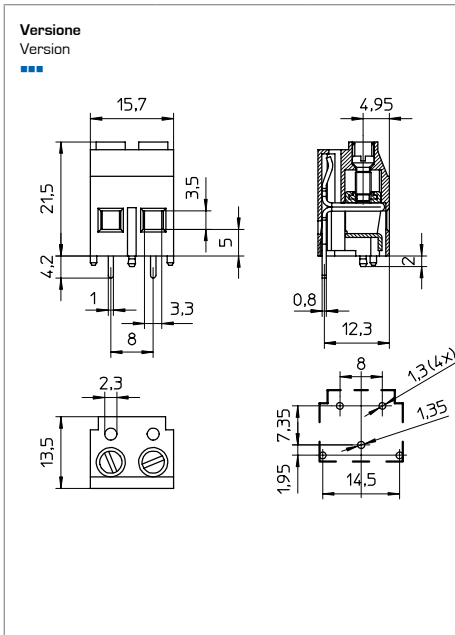

MRT26

Blocco unico
Monobloc

Single block
Einzelblock

Poli Pôles 2/12



10,16
630
57

0,5 ÷ 16 20 ÷ 6	0,5 ÷ 10 20 ÷ 6	0,5 ÷ 10 20 ÷ 6

12
1,8 / 12

110

PA G - UL 94 VO

M4

⊖ 1,2 x 6,5 and ⊕ PZ2

V	A	mm ² /AWG
750	57	0,5 ÷ 10
750	57	0,5 ÷ 10
300	58	20 ÷ 6

min 2 - max 12
GR
D/A1

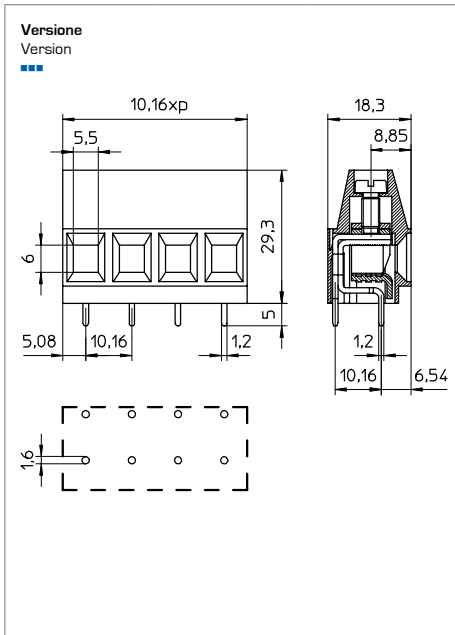

MRT27

Modulo componibile
Elements modulaires

Interlocking modules
Zusammensteckbare Blöcke

Poli Pôles 2/3



10,16
630
57

0,5 ÷ 16 20 ÷ 6	0,5 ÷ 10 20 ÷ 6	0,5 ÷ 10 20 ÷ 6

12
1,8 / 12

110

PA G - UL 94 VO

M4

⊖ 1,2 x 6,5 and ⊕ PZ2

V	A	mm ² /AWG
750	57	0,5 ÷ 10
750	57	0,5 ÷ 10
300	60	20 ÷ 6

min 2 - max...
GR
D/A1

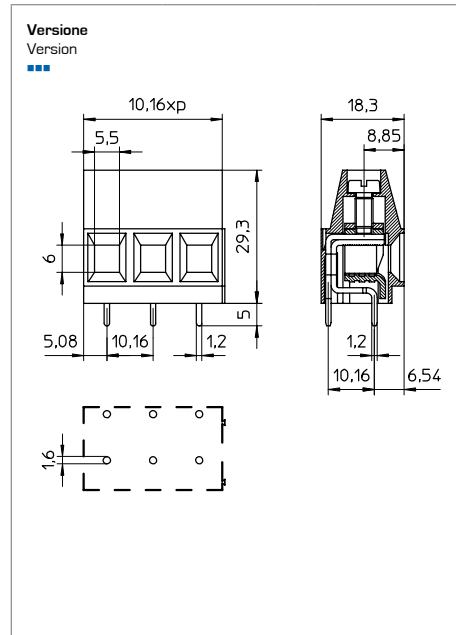

Morsetti per C.S. a linguetta

Terminal blocks for P.C.B. wire protection

Blocs de jonction C.I. languette

Printklemmen Drahtschutz



Tornito
Turned
Usiné
Gedreht



Tranciato
Punched
Découpé
Gestanzt

Pag.	Tipo Type Typ				Tornito Turned Usiné Gedreht	Tranciato Punched Découpé Gestanzt		GWT*	THR*	Passo Pitch Pas Rastermaß												
										3,5	3,81	5	5,08	6,35	7	7,5	7,62	8	9,52	10	10,16	
24	CZM	●	●	●		●	●	●	●			●										●
25	CZI	●	●	●		●	●	●	●			●										●
25+27	MRT12	●			●	●	●	●	V	V		●			●							●
27	CMM	●		●		●	●	●	●			●										●
28	CZZ	●	●	●		●	●	●	●			●										●
29	CBL	●			●	●	●	●	●	V		●										●

Numerazione a richiesta.

Vite con testa a croce su richiesta.

Printing on request.

Combi head screw on request.

Numérotation suivant demande.

Vis avec empreinte cruciforme suivant demande.

Bedruckung nach Kundenwunsch.

Kombischraube auf Anfrage.

GWT*

● Versione standard compatibile / Standard version compliant / Version standard compatible / Standardversion Kompatibel

V A richiesta / On demand / Sur demande / bei Bedarf

THR*

V A richiesta / On demand / Sur demande / bei Bedarf

* Vedi dati tecnici / See technical data / cf. données techniques / siehe technische Daten

Morsetti per C.S. linguetta

Terminal blocks for P.C.B. wire protection

Blocs de jonction C.I. linguette

Printklemmen Drahtschutz

A2

Passo Pas	Pitch Rastermaß	mm
Tensione nominale Tension nominale	Rated Voltage Bemessungsspannung	V
Corrente nominale Intensité nominale	Rated Current Bemessungsstrom	A

Tipo cavi Type du conducteur	Types of cables Leitungstypen	
Sezione nominale Section nominale	Nominal cross section Nennquerschnitt	mm ² AWG
Lunghezza spelatura Longueur de dénudage	Stripping length Abisolierlänge	mm
Coppia di torsione Couple de serrage	Torque Drehmoment	Nm Lb-in
Temperatura Température	Temperature Temperatur	°C
Corpo isolante Corps isolant	Housing Isolierkörper	
Vite Vis	Screw Schraube	

	IMQ	EN60998
	VDE	EN60998
	cUL	UL1059 + C22.2 n°158

Poli Pôles	Poles Polzahl	X
Colore standard Coloris standard	Standard colour Standardfarbe	Y
Altri dati Autres données	Other information Weitere Informationen	Pag Seite

Ordinazione Référence de commande		How to order Bestellschlüssel			
CZM	5	/ X	...	Y	N...
Tipo	Passo	Poli	Versione	Colori	Numerazione
Type	Pitch	Poles	Version	Colors	Printing
Type	Pas	Pôles	Version	Couleurs	Marquage
Type	Rastermaß	Polzahl	Version	Farben	Bedruckung

Altri colori a richiesta Autres couleurs sur demande	Other colours on demand Andere Farben bei Bedarf

CZM CZM..SQ

Modulo componibile Elements modulaires Interlocking modules Zusammensteckbare Blöcke

Poli Pôles Poles Polzahl 2/3



5
200
13,5

0,5 ÷ 1,5 30 ÷ 14	0,5 ÷ 1 30 ÷ 14	0,5 ÷ 1 30 ÷ 14
6		
0,4	/	3
85		
PC - UL 94 VO		
M2,5		
0,6 x 3,5		

V	A	mm²/AWG
250	13,5	0,5 ÷ 1
250	13,5	0,5 ÷ 1
300	14	26 ÷ 14

min 2 - max.
GR
D/A2

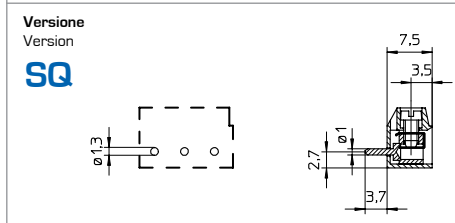
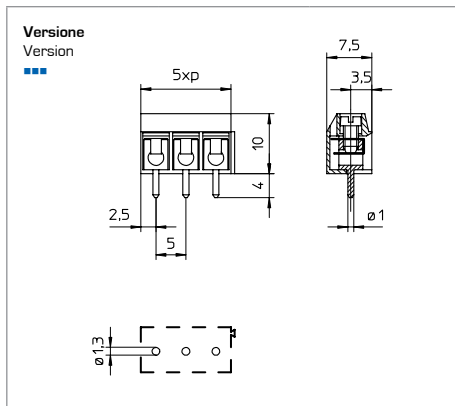

CZM CZM..SQ

Modulo componibile Elements modulaires Interlocking modules Zusammensteckbare Blöcke

Poli Pôles Poles Polzahl 1/2



10
500
13,5

0,5 ÷ 1,5 30 ÷ 14	0,5 ÷ 1 30 ÷ 14	0,5 ÷ 1 30 ÷ 14
6		
0,4	/	3
85		
PC - UL 94 VO		
M2,5		
0,6 x 3,5		

V	A	mm²/AWG
750	13,5	0,5 ÷ 1
750	13,5	0,5 ÷ 1
300	14	26 ÷ 14

min 2 - max..
GR
D/A2

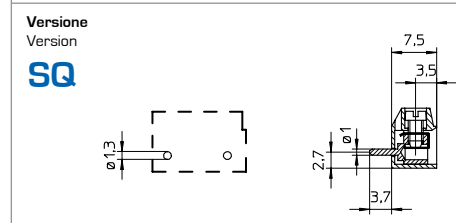
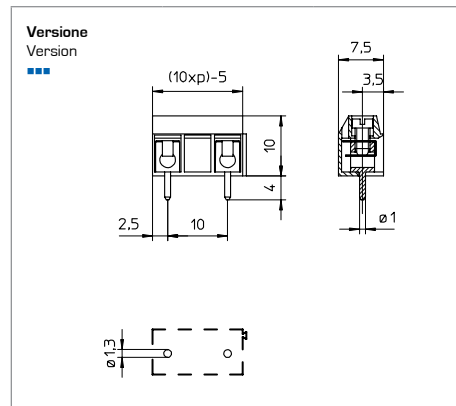

CZI

CZI..SQ

Blocco unico
Monobloc

Single block
Einzelblock

Poli
Póles

Poles
Polzahl

2/24



5

200

13,5

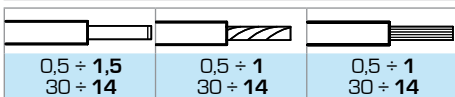

0,5 ÷ 1,5
30 ÷ 14

0,5 ÷ 1
30 ÷ 14

0,5 ÷ 1
30 ÷ 14

6

0,4

/

3

85

PC - UL 94 VO

M2,5



0,6 x 3,5

V

A

mm²/AWG

250

13,5

0,5 ÷ 1

250

13,5

0,5 ÷ 1

300

14

26 ÷ 14

min 2 - max 24

GR

D/A2

Versione
Version

■ ■ ■

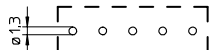
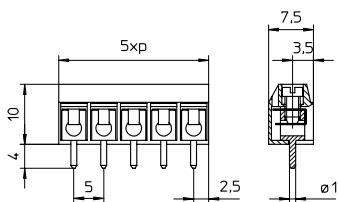

Versione
Version

SQ

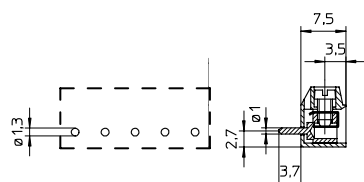

CZI

CZI..SQ

Blocco unico
Monobloc

Single block
Einzelblock

Poli
Póles

Poles
Polzahl

2/12



10

500

13,5

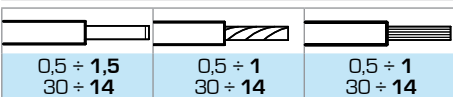

0,5 ÷ 1,5
30 ÷ 14

0,5 ÷ 1
30 ÷ 14

0,5 ÷ 1
30 ÷ 14

6

0,4

/

3

85

PC - UL 94 VO

M2,5



0,6 x 3,5

V

A

mm²/AWG

750

13,5

0,5 ÷ 1

750

13,5

0,5 ÷ 1

300

14

26 ÷ 14

min 2 - max 12

GR

D/A2

Versione
Version

■ ■ ■

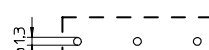
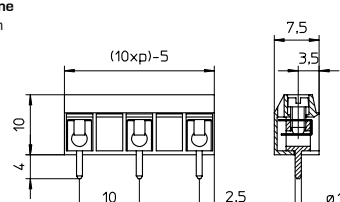

Versione
Version

SQ

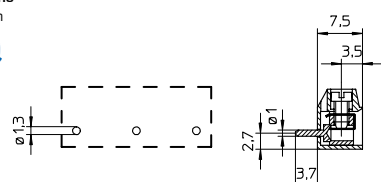

MRT12

Blocco unico
Monobloc

Single block
Einzelblock

Poli
Póles

Poles
Polzahl

2/24



5

250

24

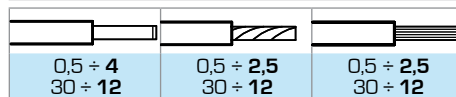

0,5 ÷ 4
30 ÷ 12

0,5 ÷ 2,5
30 ÷ 12

0,5 ÷ 2,5
30 ÷ 12

6

0,4

/

3

110

PA - UL 94 VO

M2,5



0,6 x 3,5

V

A

mm²/AWG

250

24

0,2 ÷ 2,5

250

24

0,2 ÷ 2,5

300

16

30 ÷ 12

min 2 - max 24

VE

D/A2

Versione
Version

■ ■ ■

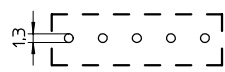
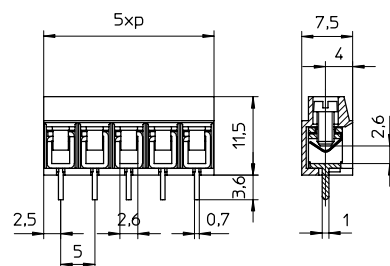

A2

Morsetti per C.S. linguetta

Terminal blocks for P.C.B. wire protection

Blocs de jonction C.I. linguette

Printklemmen Drahtschutz

A2

Passo Pas	Pitch Rastermaß	mm
Tensione nominale Tension nominale	Rated Voltage Bemessungsspannung	V
Corrente nominale Intensité nominale	Rated Current Bemessungsstrom	A

Tipo cavi Type du conducteur	Types of cables Leitungstypen	
Sezione nominale Section nominale	Nominal cross section Nennquerschnitt	mm ² AWG
Lunghezza spelatura Longueur de dénudage	Stripping length Abisolierlänge	mm
Coppia di torsione Couple de serrage	Torque Drehmoment	Nm Lb-in
Temperatura Température	Temperature Temperatur	°C
Corpo isolante Corps isolant	Housing Isolierkörper	
Vite Vis	Screw Schraube	

	IMQ	EN60998
	VDE	EN60998
	cUL	UL1059 + C22.2 n°158

Poli Pôles	Poles Polzahl	X
Colore standard Coloris standard	Standard colour Standardfarbe	Y
Altri dati Autres données	Other information Weitere Informationen	Pag Seite

Ordinazione Référence de commande	How to order Bestellschlüssel
MRT12 P7,5 / X	... Y N...
Tipo	Versione
Type	Colors
Type	Version
Typ	Farben
	Bedruckung

Altri colori a richiesta Autres couleurs sur demande	Other colours on demand Andere Farben bei Bedarf

MRT12

Blocco unico
Monobloc

Single block
Einzelblock

Poli
Poles

Poles
Polzahl

2/12



7,5
500
24

0,5 ÷ 4 30 ÷ 12	0,5 ÷ 2,5 30 ÷ 12	0,5 ÷ 2,5 30 ÷ 12
6		
0,4	/	3
110		
PA - UL 94 VO		
M2,5		
	0,6 x 3,5	

V	A	mm²/AWG
750	24	0,2 ÷ 2,5
750	24	0,2 ÷ 2,5
300	16	30 ÷ 12

min 2 - max 12
VE
D/A2

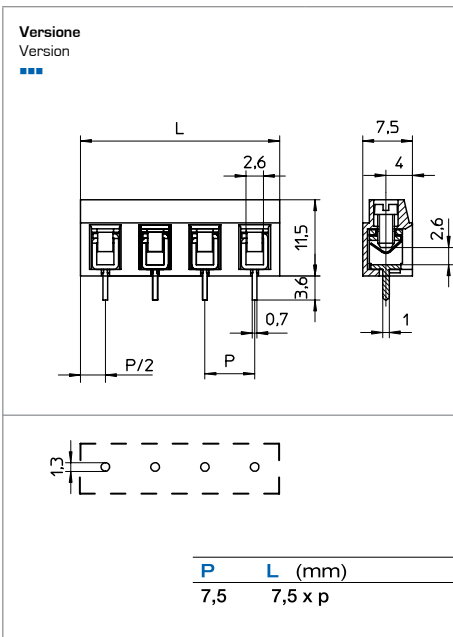

MRT12..V01

Blocco unico
Monobloc

Single block
Einzelblock

Poli
Pôles

Poles
Polzahl

2



7,5
500
24

0,5 ÷ 4 30 ÷ 12	0,5 ÷ 2,5 30 ÷ 12	0,5 ÷ 2,5 30 ÷ 12
6		
0,4	/	3
110		
PA - UL 94 VO		
M2,5		
	0,6 x 3,5	

V	A	mm²/AWG
750	24	0,2 ÷ 2,5
750	24	0,2 ÷ 2,5
300	16	30 ÷ 12

2
VE
D/A2

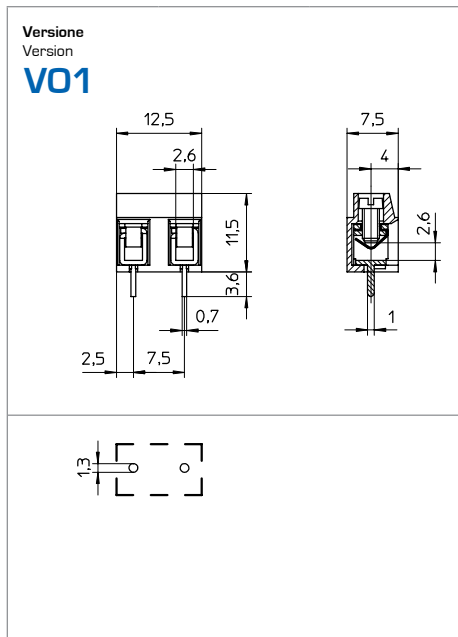

MRT12

Blocco unico
Monobloc

Single block
Einzelblock

Poli
Pôles

Poles
Polzahl

2/12



10

630

24

0,5 ÷ 4 30 ÷ 12	0,5 ÷ 2,5 30 ÷ 12	0,5 ÷ 2,5 30 ÷ 12

6

0,4

/

3

110

PA - UL 94 VO

M2,5



0,6 x 3,5

V	A	mm ² /AWG
750	24	0,2 ÷ 2,5
750	24	0,2 ÷ 2,5
300	16	30 ÷ 12

min 2 - max 12

VE

D/A2

Versione
Version

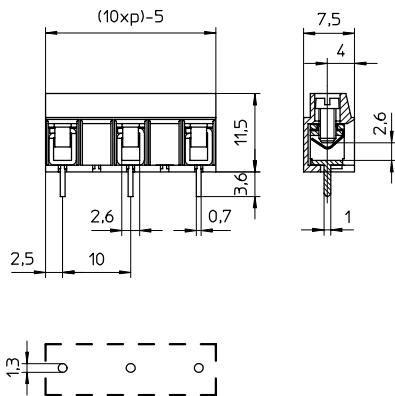

CMM

Modulo componibile
Elements modulaires

Interlocking modules
Zusammensteckbare Blöcke

Poli
Pôles

Poles
Polzahl

2/3



5

250

24

0,5 ÷ 4 30 ÷ 14	0,5 ÷ 2,5 30 ÷ 14	0,5 ÷ 2,5 30 ÷ 14

7

0,5

/

4

85

PC - UL 94 VO

M3



0,6 x 3,5

V	A	mm ² /AWG
450	24	0,5 ÷ 2,5
450	24	0,5 ÷ 2,5
300	16	24 ÷ 14

min 2 - max...

GR

D/A2

Versione
Version

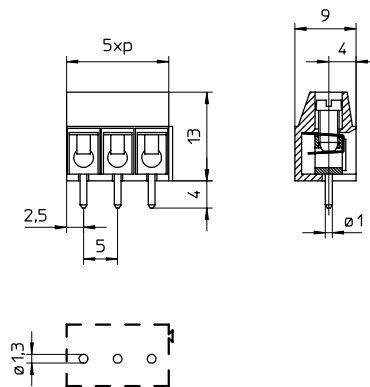

CMM

Modulo componibile
Elements modulaires

Interlocking modules
Zusammensteckbare Blöcke

Poli
Pôles

Poles
Polzahl

1/2



10

500

24

0,5 ÷ 4 30 ÷ 14	0,5 ÷ 2,5 30 ÷ 14	0,5 ÷ 2,5 30 ÷ 14

7

0,5

/

4

85

PC - UL 94 VO

M3



0,6 x 3,5

V	A	mm ² /AWG
750	24	0,5 ÷ 2,5
750	24	0,5 ÷ 2,5
300	16	24 ÷ 14

min 2 - max...

GR

D/A2

Versione
Version

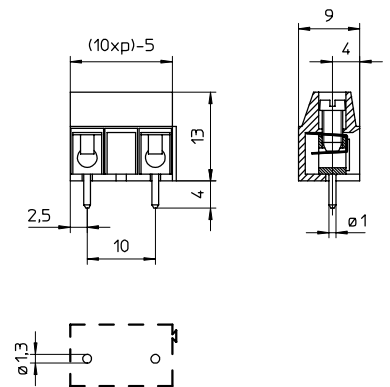

A2

Morsetti per C.S. linguetta

Terminal blocks for P.C.B. wire protection

Blocs de jonction C.I.
linguette

Printklemmen
Drahtschutz

A2

CZZ CZZ..SQ

Blocco unico Monobloc Single block Einzelblock

Poli Poles 2/24



5
250
24

0,5 ÷ 4 30 ÷ 14	0,5 ÷ 2,5 30 ÷ 14	0,5 ÷ 2,5 30 ÷ 14
7		
0,5 / 4		
85		
PC - UL 94 VO		
M3		
0,6 x 3,5		

V	A	mm ² /AWG
450	24	0,5 ÷ 2,5
450	24	0,5 ÷ 2,5
300	16	24 ÷ 14

min 2 - max 24
GR
D/A2

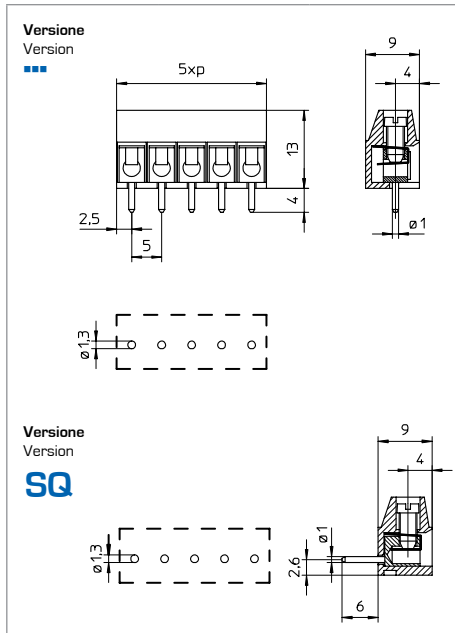

CZZ CZZ..SQ

Blocco unico Monobloc Single block Einzelblock

Poli Poles 2/12



10
500
24

0,5 ÷ 4 30 ÷ 14	0,5 ÷ 2,5 30 ÷ 14	0,5 ÷ 2,5 30 ÷ 14
7		
0,5 / 4		
85		
PC - UL 94 VO		
M3		
0,6 x 3,5		

V	A	mm ² /AWG
750	24	0,5 ÷ 2,5
750	24	0,5 ÷ 2,5
300	16	24 ÷ 14

min 2 - max 12
GR
D/A2

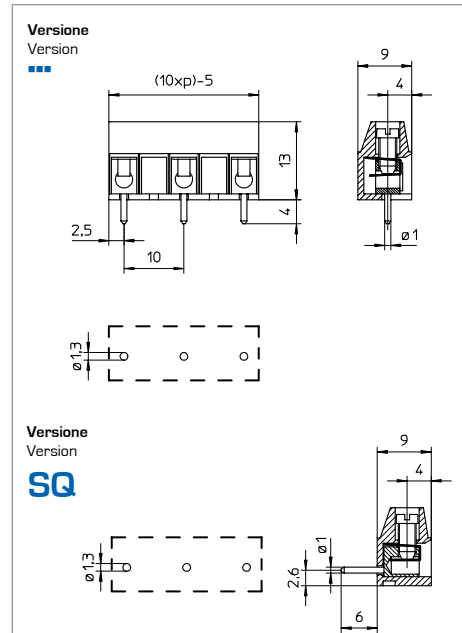

Passo Pas	Pitch Rastermaß	mm
Tensione nominale Tension nominale	Rated Voltage Bemessungsspannung	V
Corrente nominale Intensité nominale	Rated Current Bemessungsstrom	A

Tipo cavi	Types of cables	
Type du conducteur	Leitungstypen	
Sezione nominale Section nominale	Nominal cross section Nennquerschnitt	mm² AWG
Lunghezza spelatura Longueur de dénudage	Stripping length Abisolierlänge	mm
Coppia di torsione Couple de serrage	Torque Drehmoment	Nm Lb-in
Temperatura Température	Temperature Temperatur	°C
Corpo isolante Corps isolant	Housing Isolierkörper	
Vite Vis	Screw Schraube	

	IMQ	EN60998
	VDE	EN60998
	cUL	UL1059 + C22.2 n°158

Poli Pôles	Poles Polzahl	X
Colore standard Coloris standard	Standard colour Standardfarbe	Y
Altri dati Autres données	Other information Weitere Informationen	Pag Seite

Ordinazione	How to order				
Référence de commande	Bestellschlüssel				
CZZ 5 / X	SQ Y N...				
Tipo Type	Passo Pitch	Poli Poles	Versione Version	Colori Colors	Numerazione Marquage
Type	Pas	Pôles	Version	Couleurs	Marquage
Typ	Rastermaß	Polzahl	Version	Farben	Bedruckung

Altri colori a richiesta	Other colours on demand
Autres couleurs sur demande	Andere Farben bei Bedarf
VE GR NE AR BL RO	

CBL

Blocco unico
Monobloc

Single block
Einzelblock

Poli
Póles

Poles
Polzahl

2/24



5

250

24

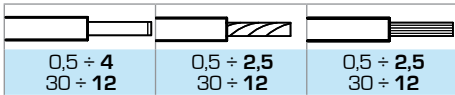

0,5 ÷ 4
30 ÷ 12

0,5 ÷ 2,5
30 ÷ 12

0,5 ÷ 2,5
30 ÷ 12

7

0,5

/

4

85

PC - UL 94 VO

M2,5



0,6 x 3,5

V	A	mm ² /AWG
250	24	0,2 ÷ 2,5
250	24	0,2 ÷ 2,5
300	18	30 ÷ 12

min 2 - max 24

GR

D/A2

Versione
Version

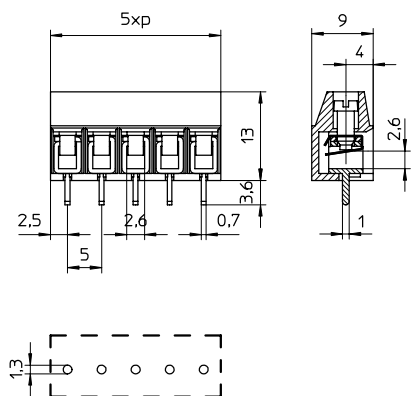

CBL

Blocco unico
Monobloc

Single block
Einzelblock

Poli
Póles

Poles
Polzahl

2/12



10

500

24

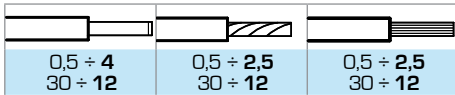

0,5 ÷ 4
30 ÷ 12

0,5 ÷ 2,5
30 ÷ 12

0,5 ÷ 2,5
30 ÷ 12

7

0,5

/

4

85

PC - UL 94 VO

M2,5



0,6 x 3,5

V	A	mm ² /AWG
750	24	0,2 ÷ 2,5
750	24	0,2 ÷ 2,5
300	18	30 ÷ 12

min 2 - max 12

GR

D/A2

Versione
Version

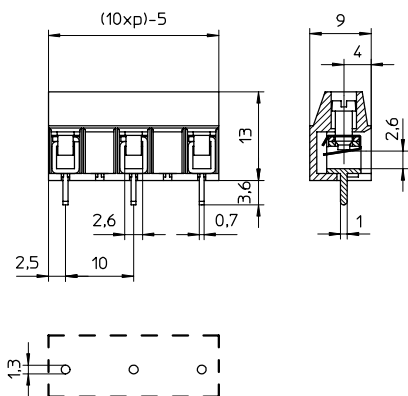

Morsetti per C.S. a molla

Terminal blocks for P.C.B. screwless

Blocs de jonction C.I. ressort

Printklemmen Federkraft

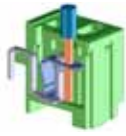

Tranciato
Punched
Découpé
Gestanzt

A3

Pag.	Tipo Type Type Typ		Tornito Turned Usiné Gedreht	Tranciato Punched Découpé Gestanzt				GWT*	THR*	Passo Pitch Pas Rastermaß												
										3,5	3,81	5	5,08	6,35	7	7,5	7,62	8	9,52	10	10,16	
32-33	MRT24	•	•	•	•	•	•	V		•	•				•		•					
33-34	MRT1	•		•	•	•	•	V				•	•			•	•				•	•
34-35	MRT23	•		•	•	•	•	V					•									•
35	CTL	•		•	•	•	•	V				•										•

Numerazione a richiesta.

Printing on request.

Numérotation suivant demande.

Bedruckung nach Kundenwunsch.

GWT*

● Versione standard compatibile / Standard version compliant / Version standard compatible / Standardversion Kompatibel
V A richiesta / On demand / Sur demande / bei Bedarf

THR*

V A richiesta / On demand / Sur demande / bei Bedarf

* Vedi dati tecnici / See technical data / cf. données techniques / siehe technische Daten

Morsetti per C.S. molla

Terminal blocks for P.C.B. screwless

Blocs de jonction C.I.
ressort

Printklemmen
Federkraft

MRT24..V04

MRT24..V05

Modulo componibile
Elements modulaires

Interlocking modules
Zusammensteckbare Blöcke

Pole Pole 1



3,5	3,81
250	
4	

0,5 ÷ 1,5 30 ÷ 16	0,5 ÷ 1,5 30 ÷ 16	0,5 ÷ 1,5 30 ÷ 16
7		
110		
PA - UL 94 VO		

V	A	mm ² /AWG
250	4	0,5 ÷ 0,75
250	4	0,5 ÷ 0,75
300	4	30 ÷ 16

min 2 - max 24		
GR		
D/A3		

Versione
Version
V04
V05

1° Pin side

P	L (mm)
3,5	(3,5 x p)+1,5
3,81	(3,81 x p)+1,5

MRT24..V01

MRT24..V02

Modulo componibile
Elements modulaires

Interlocking modules
Zusammensteckbare Blöcke

Pole Pole 1



3,5	3,81
320	
4	

0,5 ÷ 1,5 30 ÷ 16	0,5 ÷ 1,5 30 ÷ 16	0,5 ÷ 1,5 30 ÷ 16
7		
110		
PA - UL 94 VO		

V	A	mm ² /AWG
450	4	0,5 ÷ 0,75
450	4	0,5 ÷ 0,75
300	4	30 ÷ 16

min 2 - max 24		
GR		
D/A3		

Versione
Version
V01
V02

1° Pin side

P	L (mm)
3,5	(3,5 x p)+1,5
3,81	(3,81 x p)+1,5

Passo Pas	Pitch Rastermaß	mm
Tensione nominale Tension nominale	Rated Voltage Bemessungsspannung	V
Corrente nominale Intensité nominale	Rated Current Bemessungsstrom	A

Tipo cavi Type du conducteur	Types of cables Leitungstypen	
Sezione nominale Section nominale	Nominal cross section Nennquerschnitt	mm² AWG
Lunghezza spelatura Longueur de dénudage	Stripping length Abisolierlänge	mm

Temperatura Température	Temperature Temperatur	°C
Corpo isolante Corps isolant	Housing Isolierkörper	

	IMQ	EN60998
	VDE	EN60998
	cUL	UL1059 + C22.2 n°158

Poli Pôles	Poles Polzahl	X
Colore standard Coloris standard	Standard colour Standardfarbe	Y
Altri dati Autres données	Other information Weitere Informationen	Pag Seite

Ordinazione Référence de commande	How to order Bestellschlüssel
MRT24 P3,5 / X	V04 Y N...
Tipo Type Type Typ	Versione Version Version Version
Passo Pitch Pas Rastermaß	Colori Colors Couleurs Farben
Poli Poles Pôles Polzahl	Numerazione Printing Marquage Bedruckung

Altri colori a richiesta Autres couleurs sur demande	Other colours on demand Andere Farben bei Bedarf

MRT24..V04

MRT24..V05

Modulo componibile
Elements modulaires

Interlocking modules
Zusammensteckbare Blöcke

Polo Pole 1



7	7,62
500	
4	

0,5 ÷ 1,5 30 ÷ 16	0,5 ÷ 1,5 30 ÷ 16	0,5 ÷ 1,5 30 ÷ 16
7		
110		
PA - UL 94 VO		

V	A	mm ² /AWG
750	4	0,5 ÷ 0,75
750	4	0,5 ÷ 0,75
300	4	30 ÷ 16

min 2 - max 12		
GR		
D/A3		

Versione
Version
V04
V05

P	L (mm)
7	(7 x p)-2
7,62	(7,62 x p)-2,31

MRT1

Modulo componibile
Elements modulaires

Interlocking modules
Zusammensteckbare Blöcke

Polo Pole 1



5	5,08
250	
10	

0,5 ÷ 1,5 30 ÷ 16	0,5 ÷ 1,5 30 ÷ 16	0,5 ÷ 1,5 30 ÷ 16
10		
110		
PA - UL 94 VO		

V	A	mm ² /AWG
250	10	0,5 ÷ 1,5
250	10	0,5 ÷ 1,5
300	10	30 ÷ 16

min 2 - max 24		
GR		
D/A3		

Versione
Version
...

P	L (mm)	X
5	(5 x p)+1,5	3
5,08	(5,08 x p)+1,5	3,08

MRT1

Modulo componibile
Elements modulaires

Interlocking modules
Zusammensteckbare Blöcke

Polo Pole 1



7,5	7,62
500	
10	

0,5 ÷ 1,5 30 ÷ 16	0,5 ÷ 1,5 30 ÷ 16	0,5 ÷ 1,5 30 ÷ 16
10		
110		
PA - UL 94 VO		

V	A	mm ² /AWG
750	10	0,5 ÷ 1,5
750	10	0,5 ÷ 1,5
300	10	30 ÷ 16

min 2 - max 18		
GR		
D/A3		

Versione
Version
...

P	L (mm)	X
7,5	(7,5 x p)-1	3
7,62	(7,62 x p)-1	3,08

A3

Morsetti per C.S. molla

Terminal blocks for P.C.B. screwless

Blocs de jonction C.I.
ressort

Printklemmen
Federkraft

A3

Passo Pas	Pitch Rastermaß	mm
Tensione nominale Tension nominale	Rated Voltage Bemessungsspannung	V
Corrente nominale Intensité nominale	Rated Current Bemessungsstrom	A

Tipo cavi Type du conducteur	Types of cables Leitungstypen	
Sezione nominale Section nominale	Nominal cross section Nennquerschnitt	mm ² AWG
Lunghezza spelatura Longueur de dénudage	Stripping length Abisolierlänge	mm

Temperatura Température	Temperature Temperatur	°C
Corpo isolante Corps isolant	Housing Isolierkörper	

	IMQ	EN60998
	VDE	EN60998
	cUL	UL1059 + C22.2 n°158

Poli Pôles	Poles Polzahl	X
Colore standard Coloris standard	Standard colour Standardfarbe	Y
Altri dati Autres données	Other information Weitere Informationen	Pag Seite

Ordinazione Référence de commande	How to order Bestellschlüssel				
MRT1 P10 / X ... Y N...					
Tipo	Passo	Poli	Versione	Colori	Numerazione
Type	Pitch	Poles	Version	Colors	Printing
Type	Pas	Pôles	Version	Couleurs	Marquage
Type	Rastermaß	Polzahl	Version	Farben	Bedruckung

Altri colori a richiesta Autres couleurs sur demande	Other colours on demand Andere Farben bei Bedarf				

MRT1

Modulo componibile
Elements modulaires

Interlocking modules
Zusammensteckbare Blöcke

Polo Pôle	Pole Pol	1
---------------------	--------------------	----------



10	10,16
630	
10	

0,5 ÷ 1,5 30 ÷ 16	0,5 ÷ 1,5 30 ÷ 16	0,5 ÷ 1,5 30 ÷ 16
10		

110
PA - UL 94 VO

V	A	mm²/AWG
750	10	0,5 ÷ 1,5
750	10	0,5 ÷ 1,5
300	10	30 ÷ 16

min 2 - max 12
GR
D/A3

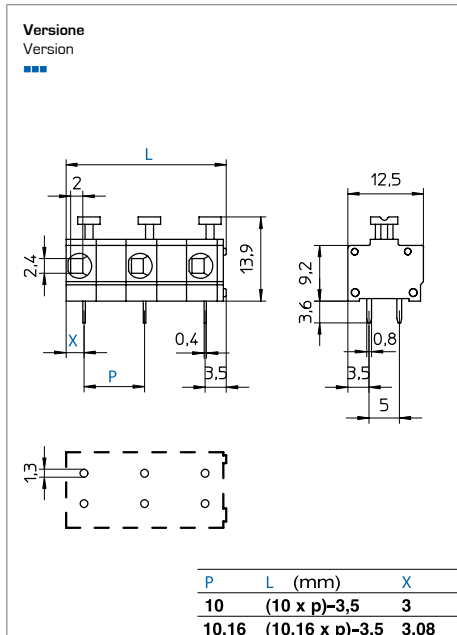

MRT23

Blocco unico
Monobloc

Single block
Einzelblock

Poli Pôles	Poles Polzahl	2/24
----------------------	-------------------------	-------------



5,08
320
16

0,5 ÷ 1,5 30 ÷ 16	0,5 ÷ 1,5 30 ÷ 16	0,5 ÷ 1,5 30 ÷ 16
7		

110
PA - UL 94 VO

V	A	mm²/AWG
450	16	0,5 ÷ 1,5
450	16	0,5 ÷ 1,5
300	10	30 ÷ 16

min 2 - max 24
GR
D/A3

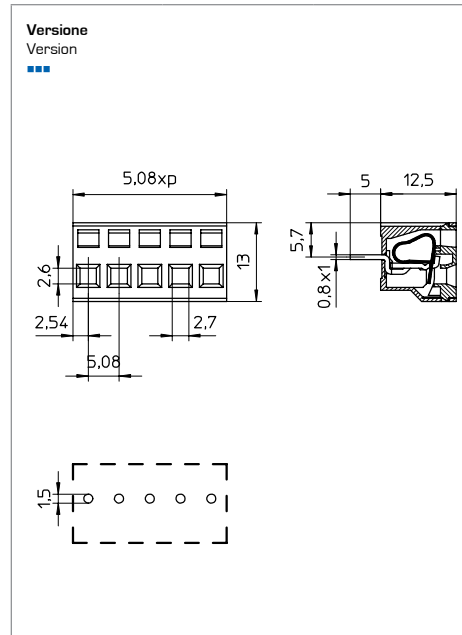

MRT23

Blocco unico
Monobloc

Single block
Einzelblock

Poli
Pöles

Poles
Polzahl

2/12



10,16

630

16

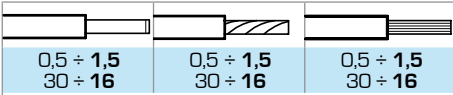

0,5 ÷ 1,5
30 ÷ 16

0,5 ÷ 1,5
30 ÷ 16

0,5 ÷ 1,5
30 ÷ 16

7

110

PA - UL 94 VO

V	A	mm ² /AWG
750	16	0,5 ÷ 1,5
750	16	0,5 ÷ 1,5
300	10	30 ÷ 16

min 2 - max 12

GR

D/A3

Versione
Version

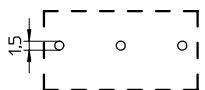
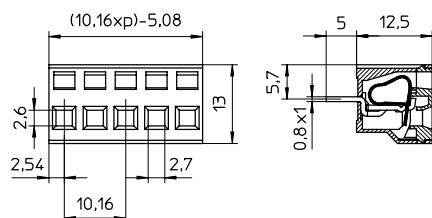

CTL

Blocco unico
Monobloc

Single block
Einzelblock

Poli
Pöles

Poles
Polzahl

2/7

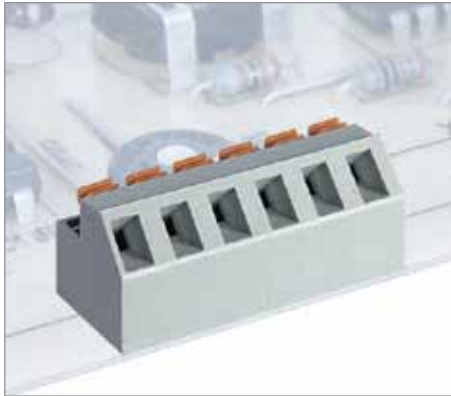

5,08

250

10

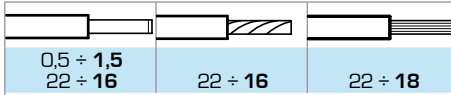

0,5 ÷ 1,5
22 ÷ 16

22 ÷ 16

22 ÷ 18

10

110

PA - UL 94 VO

V	A	mm ² /AWG
250	10	0,5 ÷ 1,5 (S)
250	10	0,5 ÷ 1,5 (S)
300	10	22 ÷ 16 (S)

min 2 - max 7

GR

D/A3

Versione
Version

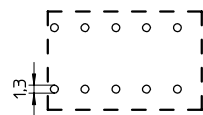
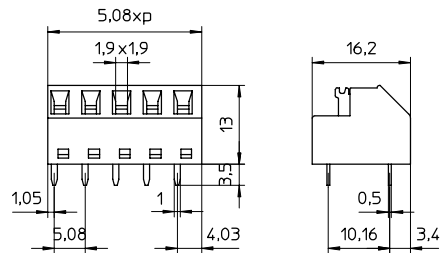

CTL

Blocco unico
Monobloc

Single block
Einzelblock

Poli
Pöles

Poles
Polzahl

2/4

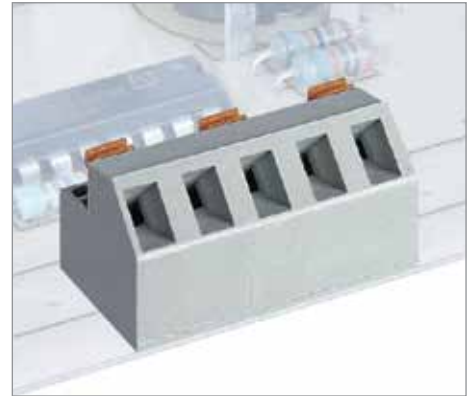

10,16

630

10

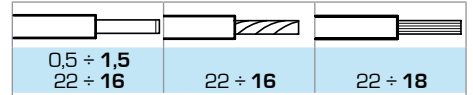

0,5 ÷ 1,5
22 ÷ 16

22 ÷ 16

22 ÷ 18

10

110

PA - UL 94 VO

V	A	mm ² /AWG
750	10	0,5 ÷ 1,5 (S)
750	10	0,5 ÷ 1,5 (S)
300	10	22 ÷ 16 (S)

min 2 - max 4

GR

D/A3

Versione
Version

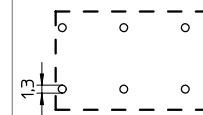
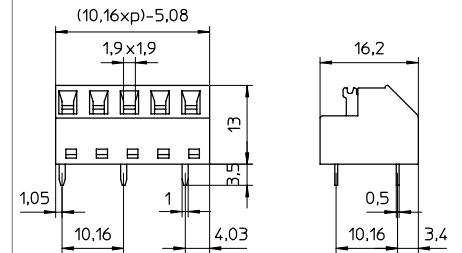

A3

Connettori femmina a carrello

Rising clamp female plug

Connecteurs femelle étrier remontant

Liftprinzip - Steckerteil



Tornito
Turned
Usiné
Gedreht



Tranciato
Punched
Découpé
Gestanzt

Pag.	Tipo Type Typ	Tornito			Tranciato			GWT*	Passo Pitch Pas Rastermaß												
		Turned Usiné Gedreht	Punched Découpé Gestanzt	Turned Usiné Gedreht	Punched Découpé Gestanzt	Turned Usiné Gedreht	Punched Découpé Gestanzt		Turned Usiné Gedreht	Punched Découpé Gestanzt	3,5	3,81	5	5,08	7	7,5	7,62	8,5	10	10,16	
38-39	MRT8	●	●	●	●	●	●	V	●	●			●		●						
39-41	MRT22	●	●	●		●	●	V	●	●			●		●						
41	CUF	●	●		●	●	●	●			●									●	
41-43	CPF	●	●	●		●	●	V			●	●		●	●					●	●
43-47	MRT3	●	●	●		●	●	V			●	●			●					●	●

P = pending

Numerazione a richiesta.
Accessori sezione C.
Vite con testa a croce su richiesta.
Tabella di corrispondenza connettori sezione C.

Printing on request.
Accessoires section C.
Combi head screw on request.
Connectors correspondance table section C.

Numérotation suivant demande.
Accessoires section C.
Vis avec empreinte cruciforme suivant demande.
Tableau de correspondance des connecteurs section C.

Bedruckung nach Kundenwunsch.
Zubehör Kapitel C.
Kombischraube auf Anfrage.
Steckverbinder Auswahltabelle Kapitel C.

GWT*
● Versione standard compatibile / Standard version compliant / Version standard compatible / Standardversion Kompatibel
V A richiesta / On demand / Sur demande / bei Bedarf

* Vedi dati tecnici / See technical data / cf. données techniques / siehe technische Daten

Connettori femmina carrello

Female plug rising clamp

Connecteurs femelle étrier remontant

Steckerteil Liftprinzip

MRT8

Blocco unico Monobloc	Single block Einzelblock	
Poli Poles	Poles Polzahl	2/20



3,5	3,81
200	
10	

0,2 ÷ 1,0 30 ÷ 16	0,2 ÷ 1,0 30 ÷ 16	0,2 ÷ 1,0 30 ÷ 16
5		
0,3	/	3
110		
PA - UL 94 V0		
M2		
⊕ 0,5 x 3		

V	A	mm ² /AWG
200	10	0,2 ÷ 1,0
300	8	30 ÷ 16

min 2 - max 20		
VE		
D/B1		

Versione
Version

P	L (mm)	X
3,5	3,5 x p	1,75
3,81	(3,81 x p)+0,79	2,3

MRT8..FV

Blocco unico Monobloc	Single block Einzelblock	
Poli Poles	Poles Polzahl	2/20

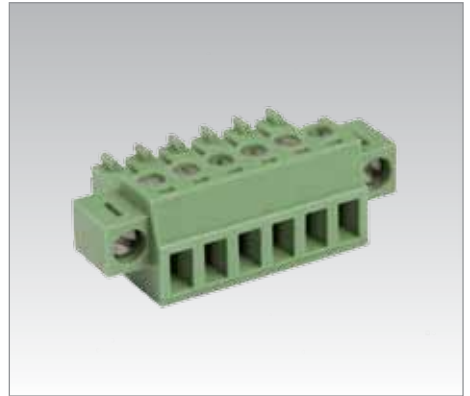

3,5	3,81
200	
10	

0,2 ÷ 1,0 30 ÷ 16	0,2 ÷ 1,0 30 ÷ 16	0,2 ÷ 1,0 30 ÷ 16
5		
0,3	/	3
110		
PA - UL 94 V0		
M2		
⊕ 0,5 x 3		

V	A	mm ² /AWG
200	10	0,2 ÷ 1,0
300	8	30 ÷ 16

min 2 - max 20		
VE		
D/B1		

Versione
Version

FV

P	L (mm)	Y	X	A
3,5	(3,5 x p)	4,3	5,1	1,75
3,81	(3,81x p)+0,79	4,5	4,8	2,3

Passo Pas	Pitch Rastermaß	mm
Tensione nominale Tension nominale	Rated Voltage Bemessungsspannung	V
Corrente nominale Intensité nominale	Rated Current Bemessungsstrom	A

Tipo cavi Type du conducteur	Types of cables Leitungstypen	
Sezione nominale Section nominale	Nominal cross section Nennquerschnitt	mm ² AWG
Lunghezza spelatura Longueur de dénudage	Stripping length Abisolierlänge	mm
Coppia di torsione Couple de serrage	Torque Drehmoment	Nm Lb-in
Temperatura Température	Temperature Temperatur	°C
Corpo isolante Corps isolant	Housing Isolierkörper	
Vite imperdibile Vis imperdable	Captive Screw Unverlierbare Schraube	

IMQ	EN61984
VDE	EN61984
cUL	UL1059 + C22.2 n°158

Poli Pôles	Poles Polzahl	X
Colore standard Coloris standard	Standard colour Standardfarbe	Y
Altri dati Autres données	Other information Weitere Informationen	Pag Seite

Ordinazione Référence de commande	How to order Bestellschlüssel				
MRT8 P3,5 / X	... Y N...				
Tipo Type	Passo Pitch	Poli Poles	Versione Version	Colori Colors	Numerazione Printing
Type	Pas	Pôles	Version	Couleurs	Marquage
Typ	Rastermaß	Polzahl	Version	Farben	Bedruckung

Altri colori a richiesta Autres couleurs sur demande	Other colours on demand Andere Farben bei Bedarf
VE GR NE AR BL RO	

MRT8

Blocco unico
Monobloc

Single block
Einzelblock

Poli Póles 7
Polzahl 7
2/10

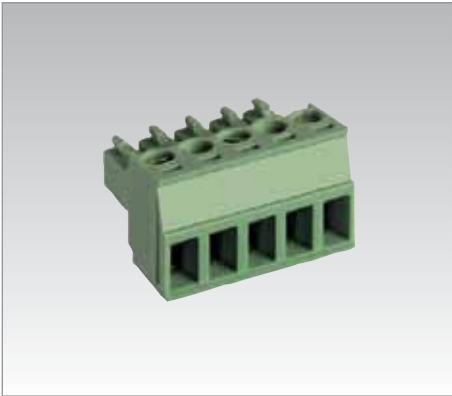

7 7,62

400 500

10

0,2 ÷ 1,0 30 ÷ 16	0,2 ÷ 1,0 30 ÷ 16	0,2 ÷ 1,0 30 ÷ 16
5		
0,3	/	3
110		
PA - UL 94 V0		
M2		
	0,5 x 3	

V	A	mm ² /AWG
400 (7)	500 (7,62)	10
300	8	30 ÷ 16

min 2 - max 10

VE

D/B1

Versione
Version

■■■

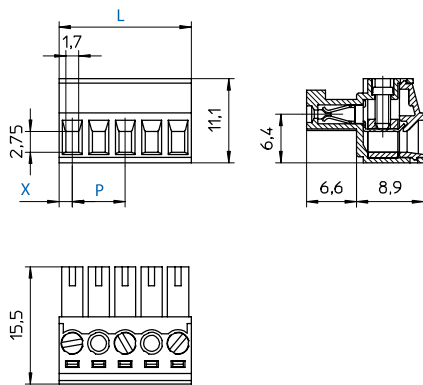

P	L (mm)	X
7	(7 x p)-3,5	1,75
7,62	(7,62 x p)-3,02	2,3

MRT8..FV

Blocco unico
Monobloc

Single block
Einzelblock

Poli Póles 7
Polzahl 7
2/10



7 7,62

400 500

10

0,2 ÷ 1,0 30 ÷ 16	0,2 ÷ 1,0 30 ÷ 16	0,2 ÷ 1,0 30 ÷ 16
5		
0,3	/	3
110		
PA - UL 94 V0		
M2		
	0,5 x 3	

V	A	mm ² /AWG
400 (7)	500 (7,62)	10
300	8	30 ÷ 16

min 2 - max 10

VE

D/B1

Versione
Version

FV

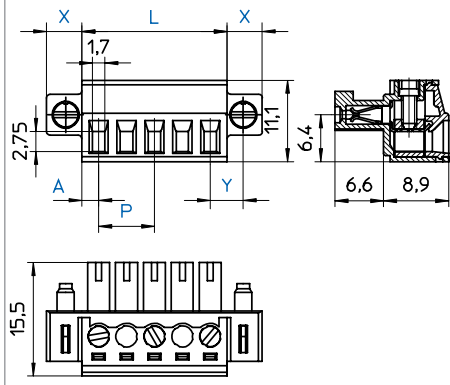

P	L (mm)	Y	X	A
7	(7 x p)-3,5	4,3	5,1	1,75
7,62	(7,62 x p)-3,02	4,5	4,8	2,3

MRT22

Blocco unico
Monobloc

Single block
Einzelblock

Poli Póles 3,5
Polzahl 3,5
2/20

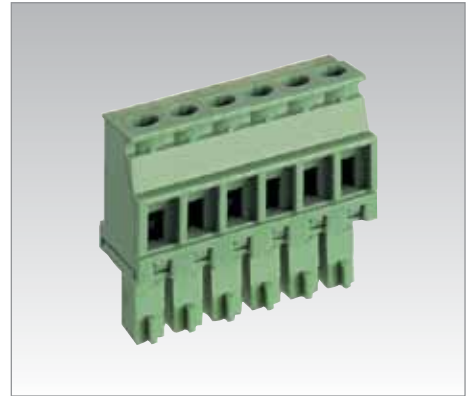

3,5 3,81

200

10

0,2 ÷ 1,0 30 ÷ 16	0,2 ÷ 1,0 30 ÷ 16	0,2 ÷ 1,0 30 ÷ 16
5		
0,3	/	2
110		
PA - UL 94 V0		
M2		
	0,5 x 3	

V	A	mm ² /AWG
200	10	0,2 ÷ 1,0
300	8	30 ÷ 16

min 2 - max 20

VE

D/B1

Versione
Version

■■■

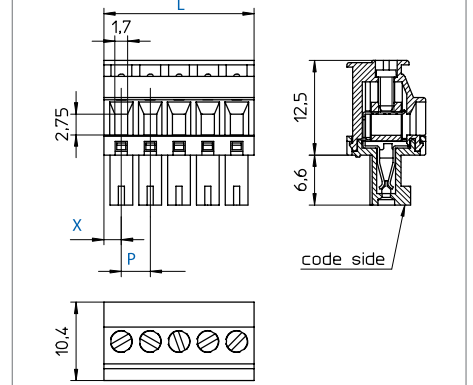

P	L (mm)	X
3,5	3,5 x p	2,15
3,81	(3,81 x p)+0,79	2,3

B1

Connettori femmina carrello

Female plug rising clamp

Connecteurs femelle étrier remontant

Steckerteil Liftprinzip

B1

Passo Pas	Pitch Rastermaß	mm
Tensione nominale Tension nominale	Rated Voltage Bemessungsspannung	V
Corrente nominale Intensité nominale	Rated Current Bemessungsstrom	A

Tipo cavi Type du conducteur	Types of cables Leitungstypen	
Sezione nominale Section nominale	Nominal cross section Nennquerschnitt	mm ² AWG
Lunghezza spelatura Longueur de dénudage	Stripping length Abisolierlänge	mm
Coppia di torsione Couple de serrage	Torque Drehmoment	Nm Lb-in
Temperatura Température	Temperature Temperatur	°C
Corpo isolante Corps isolant	Housing Isolierkörper	
Vite imperdibile Vis imperdable	Captive Screw Unverlierbare Schraube	

	IMQ	EN61984
	VDE	EN61984
	cUL	UL1059 + C22.2 n°158

Poli Pôles	Poles Polzahl	X
Colore standard Coloris standard	Standard colour Standardfarbe	Y
Altri dati Autres données	Other information Weitere Informationen	Pag Seite

Ordinazione Référence de commande	How to order Bestellschlüssel
MRT22 P3,5 / X	VO1 Y N...
Tipo Type	Passo Pitch
Poli Poles	Versione Version
Colori Couleurs	Colori Couleurs
Numerazione Marquage	Numerazione Marquage
Tip Typ	Rastermaß Polzahl

Altri colori a richiesta Autres couleurs sur demande	Other colours on demand Andere Farben bei Bedarf

MRT22..V01

Blocco unico Monobloc	Single block Einzelblock	
Poli Pôles	Poles Polzahl	2/20

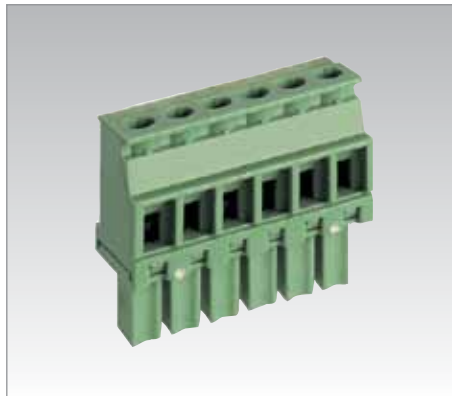

3,5	3,81
200	
10	

0,2 ÷ 1,0 30 ÷ 16	0,2 ÷ 1,0 30 ÷ 16	0,2 ÷ 1,0 30 ÷ 16
5		
0,3	/	2
110		
PA - UL 94 V0		
M2		
0,5 x 3		

V	A	mm ² /AWG
200	10	0,2 ÷ 1,0
300	8	30 ÷ 16

min 2 - max 20
D/B1

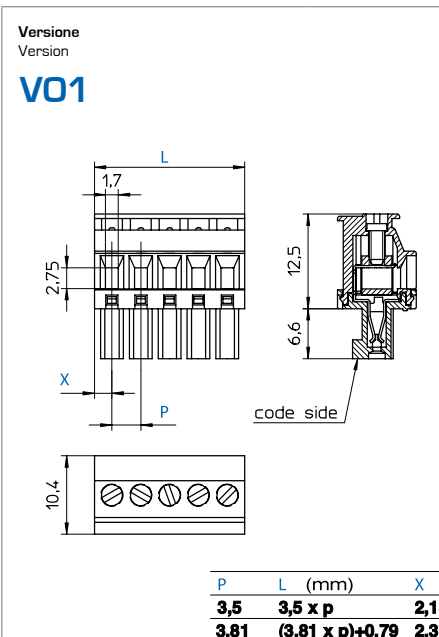

MRT22

Blocco unico Monobloc	Single block Einzelblock	
Poli Pôles	Poles Polzahl	2/10

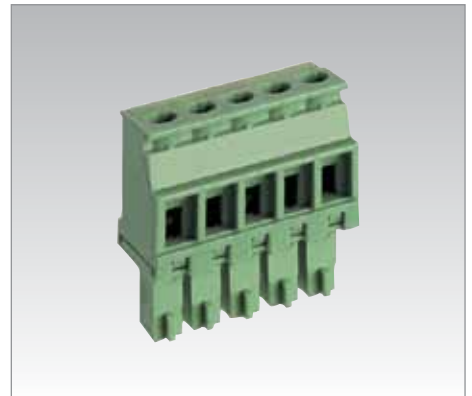

7	7,62
400	500
10	

0,2 ÷ 1,0 30 ÷ 16	0,2 ÷ 1,0 30 ÷ 16	0,2 ÷ 1,0 30 ÷ 16
5		
0,3	/	2
110		
PA - UL 94 V0		
M2		
0,5 x 3		

V	A	mm ² /AWG
400 (7)	500 (7,62)	10
300	8	30 ÷ 16

min 2 - max 10
D/B1

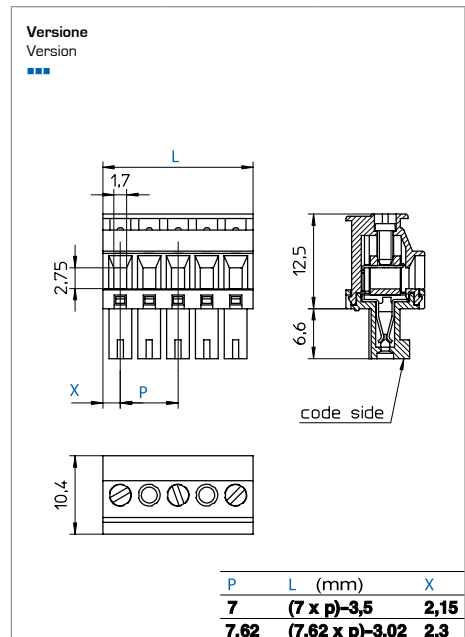

MRT22..V01

Blocco unico
Monobloc

Single block
Einzelblock

Poli
Póles

Poles
Polzahl

2/10

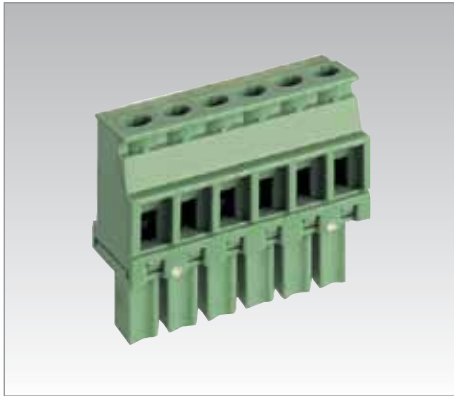

7 7,62

400 500

10

0,2 ÷ 1,0 30 ÷ 16	0,2 ÷ 1,0 30 ÷ 16	0,2 ÷ 1,0 30 ÷ 16
5		
0,3	/	2
110		
PA - UL 94 V0		
M2		
	0,5 x 3	

V		A	mm ² /AWG
400 (7)	500 (7,62)	10	0,2 ÷ 1,0
300	8	30 ÷ 16	

min 2 - max 10

VE

D/B1

Versione
Version

V01

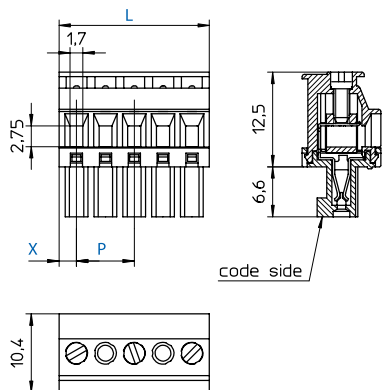

P	L (mm)	X
7	(7 x p)-3,5	2,15
7,62	(7,62 x p)-3,02	2,3

CUF

Blocco unico
Monobloc

Single block
Einzelblock

Poli
Póles

Poles
Polzahl

2/36 (5)
2/18 (10)

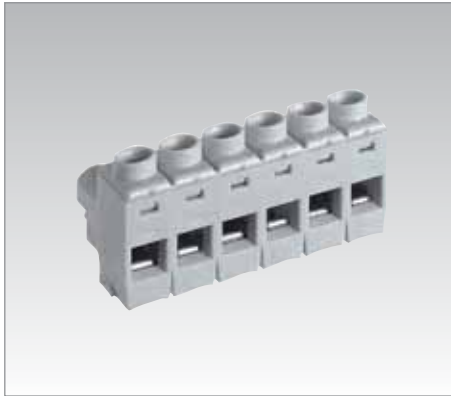

5 10

250 500

16

0,2 ÷ 2,5 24 ÷ 12	0,2 ÷ 2,5 24 ÷ 12	0,2 ÷ 2,5 24 ÷ 12
7		
0,5	/	4
130		
PC - UL 94 V0		
M2,5		
	0,6 x 3,5	

V		A	mm ² /AWG
250 (5)	500 (10)	16	0,2 ÷ 2,5
250 (5)	500 (10)	16	0,2 ÷ 2,5
300	14	24 ÷ 12	

min 2 - max...

GR

D/B1

Versione
Version

...

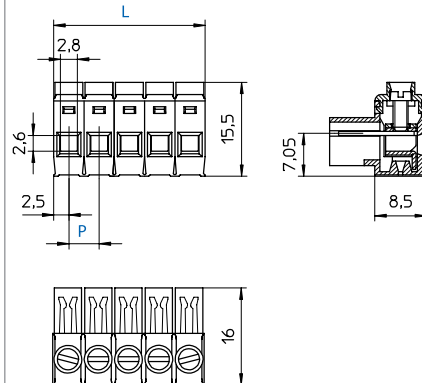

P	L (mm)
5	5 x p
10	(10 x p) -5

CPF

Blocco unico
Monobloc

Single block
Einzelblock

Poli
Póles

Poles
Polzahl

2/24

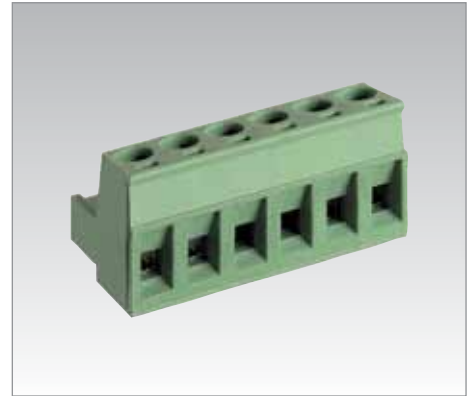

5 5,08

320

20

0,2 ÷ 2,5 30 ÷ 12	0,2 ÷ 2,5 30 ÷ 12	0,2 ÷ 2,5 30 ÷ 12
7		
0,5	/	5
160		
PA - UL 94 V0		
M3		
	0,6 x 3,5	

V		A	mm ² /AWG
320	20	0,2 ÷ 2,5	
320	20	0,2 ÷ 2,5	
300	12	24 ÷ 12	

min 2 - max 24

VE

D/B1

Versione
Version

...

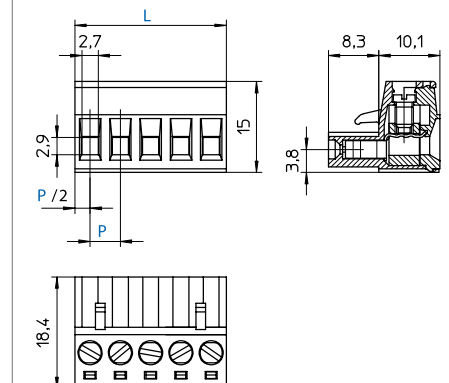

P	L (mm)
5	5 x p
5,08	5,08 x p

Connettori femmina carrello

Female plug rising clamp

Connecteurs femelle étrier remontant

Steckerteil Liftprinzip

B1

Passo Pas	Pitch Rastermaß	mm
Tensione nominale Tension nominale	Rated Voltage Bemessungsspannung	V
Corrente nominale Intensité nominale	Rated Current Bemessungsstrom	A

Tipo cavi Type du conducteur	Types of cables Leitungstypen	
Sezione nominale Section nominale	Nominal cross section Nennquerschnitt	mm ² AWG
Lunghezza spelatura Longueur de dénudage	Stripping length Abisolierlänge	mm
Coppia di torsione Couple de serrage	Torque Drehmoment	Nm Lb-in
Temperatura Température	Temperature Temperatur	°C
Corpo isolante Corps isolant	Housing Isolierkörper	
Vite imperdibile Vis imperdable	Captive Screw Unverlierbare Schraube	

	IMQ	EN61984
	VDE	EN61984
	cUL	UL1059 + C22.2 n°158

Poli Pôles	Poles Polzahl	X
Colore standard Coloris standard	Standard colour Standardfarbe	Y
Altri dati Autres données	Other information Weitere Informationen	Pag Seite

Ordinazione Référence de commande	How to order Bestellschlüssel
CPF 5 / X FV Y N...	
Tipo Type	Passo Pitch
Poli Poles	Versione Version
Colori Couleurs	Colori Farben
Numerazione Marquage	Numerazione Bedruckung

Altri colori a richiesta Autres couleurs sur demande	Other colours on demand Andere Farben bei Bedarf

CPF..FV

Blocco unico Monobloc	Single block Einzelblock	
Poli Pôles	Poles Polzahl	2/20

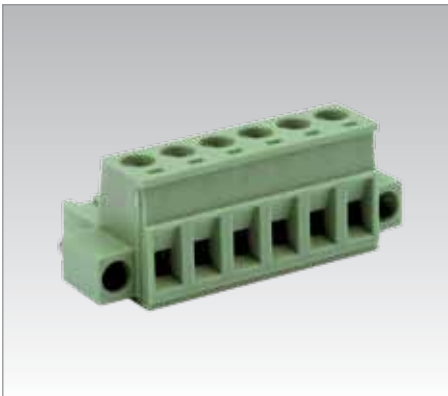

5	5,08
320	
20	

0,2 ÷ 2,5 30 ÷ 12	0,2 ÷ 2,5 30 ÷ 12	0,2 ÷ 2,5 30 ÷ 12
7		
0,5	/	5
160		
PA - UL 94 V0		
M3		
⊕ 0,6 x 3,5		

V	A	mm ² /AWG
320	20	0,2 ÷ 2,5
320	20	0,2 ÷ 2,5
300	12	24 ÷ 12

min 2 - max 20
D/B1

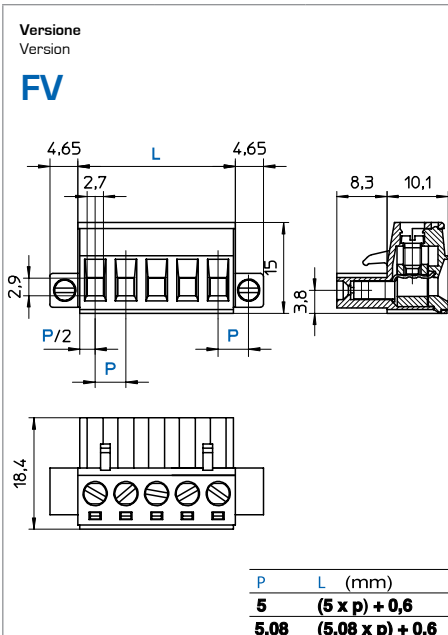

CPF

Blocco unico Monobloc	Single block Einzelblock	
Poli Pôles	Poles Polzahl	2/12



7,5	7,62
500	
20	

0,2 ÷ 2,5 30 ÷ 12	0,2 ÷ 2,5 30 ÷ 12	0,2 ÷ 2,5 30 ÷ 12
7		
0,5	/	5
160		
PA - UL 94 V0		
M3		
⊕ 0,6 x 3,5		

V	A	mm ² /AWG
500	20	0,2 ÷ 2,5
500	20	0,2 ÷ 2,5
300	12	24 ÷ 12

min 2 - max 12
D/B1

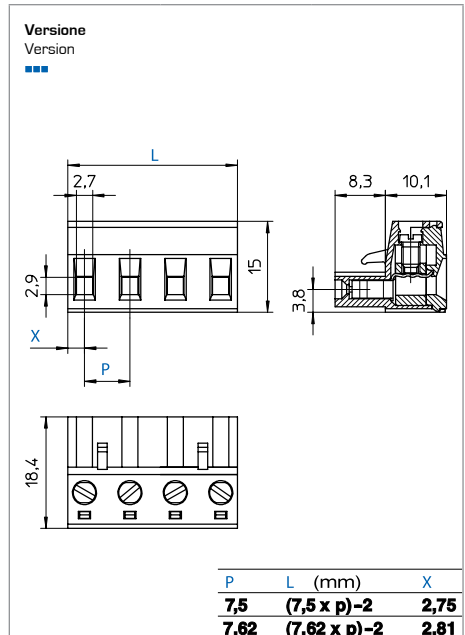

CPF

Blocco unico
Monobloc

Single block
Einzelblock

Poli
Póles

Poles
Polzahl

2/12

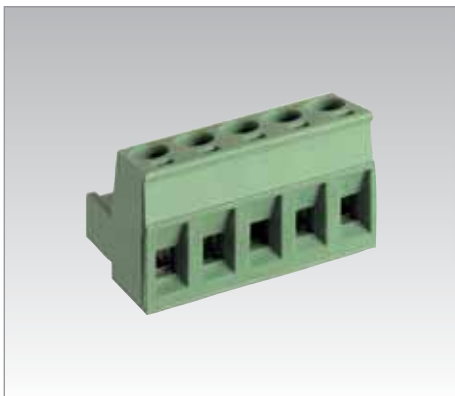

10

10,16

630

20

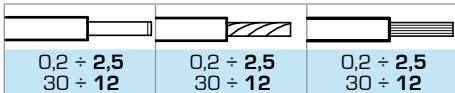

0,2 ÷ 2,5
30 ÷ 12

0,2 ÷ 2,5
30 ÷ 12

0,2 ÷ 2,5
30 ÷ 12

7

0,5

/

5

160

PA - UL 94 V0

M3



0,6 x 3,5

V

A

mm²/AWG

630

20

0,2 ÷ 2,5

630

20

0,2 ÷ 2,5

300

12

24 ÷ 12

min 2 - max 12

VE

D/B1

Versione
Version

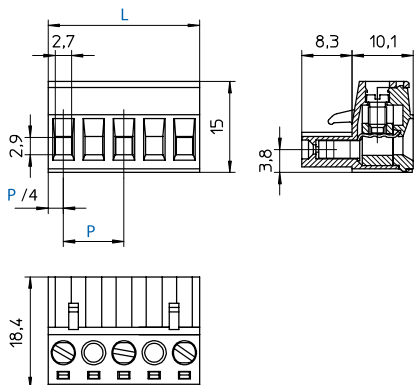

P	L (mm)
10	(10 x p) - 5
10,16	(10,16 x p) - 5,08

CPF..FV

Blocco unico
Monobloc

Single block
Einzelblock

Poli
Póles

Poles
Polzahl

2/10



10

10,16

630

20

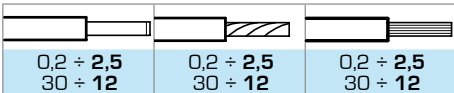

0,2 ÷ 2,5
30 ÷ 12

0,2 ÷ 2,5
30 ÷ 12

0,2 ÷ 2,5
30 ÷ 12

7

0,5

/

5

160

PA - UL 94 V0

M3



0,6 x 3,5

V

A

mm²/AWG

630

20

0,2 ÷ 2,5

630

20

0,2 ÷ 2,5

300

12

24 ÷ 12

min 2 - max 10

VE

D/B1

Versione
Version

FV

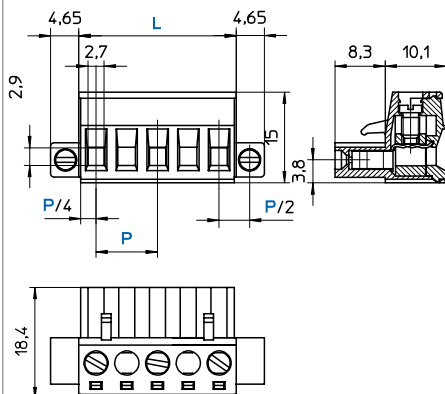

P	L (mm)
10	(10 x p) - 4,4
10,16	(10,16 x p) - 4,48

MRT3

Blocco unico
Monobloc

Single block
Einzelblock

Poli
Póles

Poles
Polzahl

2/24

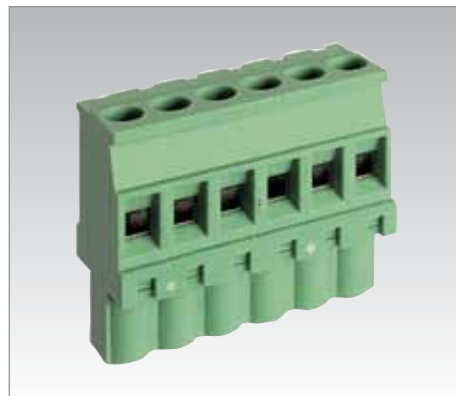

5

5,08

320

20

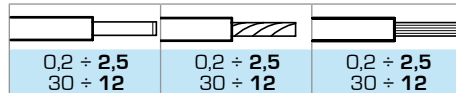

0,2 ÷ 2,5
30 ÷ 12

0,2 ÷ 2,5
30 ÷ 12

0,2 ÷ 2,5
30 ÷ 12

7

0,5

/

5

160

PA - UL 94 V0

M3



0,6 x 3,5

V

A

mm²/AWG

320

20

0,2 ÷ 2,5

320

20

0,2 ÷ 2,5

300

12

30 ÷ 12

min 2 - max 24

VE

D/B1

Versione
Version

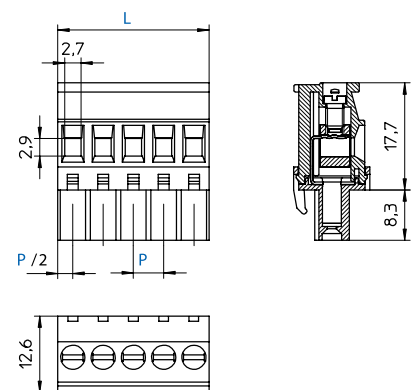

P	L (mm)
5	5 x p
5,08	5,08 x p

Connettori femmina carrello

Female plug rising clamp

Connecteurs femelle étrier remontant

Steckerteil Liftprinzip

B1

Passo Pas	Pitch Rastermaß	mm
Tensione nominale Tension nominale	Rated Voltage Bemessungsspannung	V
Corrente nominale Intensité nominale	Rated Current Bemessungsstrom	A

Tipo cavi Type du conducteur	Types of cables Leitungstypen	
Sezione nominale Section nominale	Nominal cross section Nennquerschnitt	mm ² AWG
Lunghezza spelatura Longueur de dénudage	Stripping length Abisolierlänge	mm
Coppia di torsione Couple de serrage	Torque Drehmoment	Nm Lb-in
Temperatura Température	Temperature Temperatur	°C
Corpo isolante Corps isolant	Housing Isolierkörper	
Vite imperdibile Vis imperdable	Captive Screw Unverlierbare Schraube	

	IMQ	EN61984
	VDE	EN61984
	cUL	UL1059 + C22.2 n°158

Poli Pôles	Poles Polzahl	X
Colore standard Coloris standard	Standard colour Standardfarbe	Y
Altri dati Autres données	Other information Weitere Informationen	Pag Seite

Ordinazione Référence de commande	How to order Bestellschlüssel
MRT3 P5 / X	FV Y N...
Tipo	Versione
Passo	Colori
Poli	Numerazione
Pitch	Version
Poles	Colors
Version	Coloris
Pôles	Marquage
Rastermaß	Version
Polzahl	Farben
	Bedruckung

Altri colori a richiesta Autres couleurs sur demande	Other colours on demand Andere Farben bei Bedarf

MRT3..FV

Blocco unico Monobloc	Single block Einzelblock	
Poli Pôles	Poles Polzahl	2/20



5	5,08
320	
20	

0,2 ÷ 2,5 30 ÷ 12	0,2 ÷ 2,5 30 ÷ 12	0,2 ÷ 2,5 30 ÷ 12
7		
0,5	/	5
160		
PA - UL 94 V0		
M3		
	0,6 x 3,5	

A	V	mm²/AWG
320	20	0,2 ÷ 2,5
320	20	0,2 ÷ 2,5
300	12	30 ÷ 12

min 2 - max 20
VE
D/B1

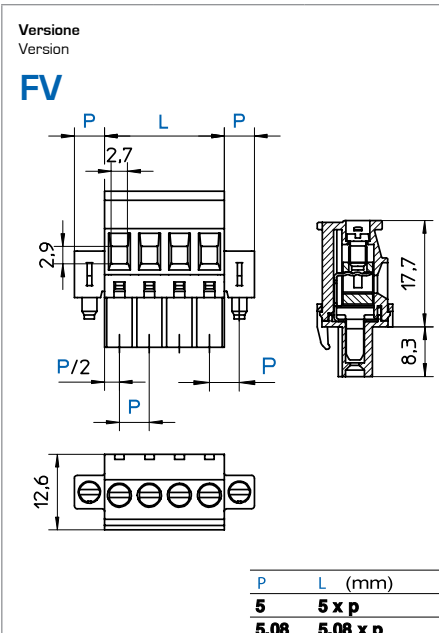

MRT3..VO1

Blocco unico Monobloc	Single block Einzelblock	
Poli Pôles	Poles Polzahl	2/24



5	5,08
320	
20	

0,2 ÷ 2,5 30 ÷ 12	0,2 ÷ 2,5 30 ÷ 12	0,2 ÷ 2,5 30 ÷ 12
7		
0,5	/	5
160		
PA - UL 94 V0		
M3		
	0,6 x 3,5	

A	V	mm²/AWG
320	20	0,2 ÷ 2,5
320	20	0,2 ÷ 2,5
300	12	30 ÷ 12

min 2 - max 24
VE
D/B1

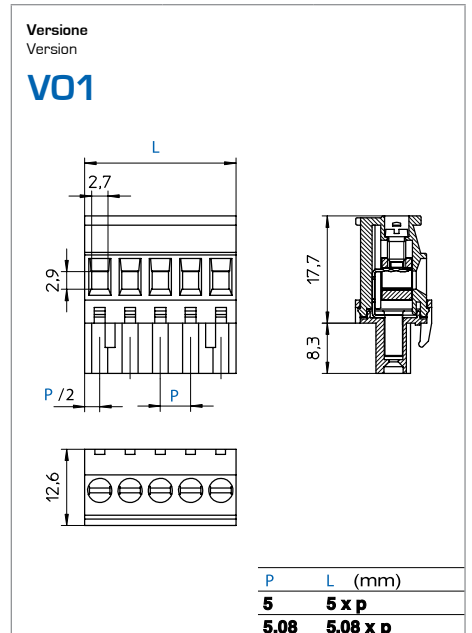

MRT3..FV V01

Blocco unico
Monobloc

Single block
Einzelblock

Poli
Pôles

Poles
Polzahl

2/20

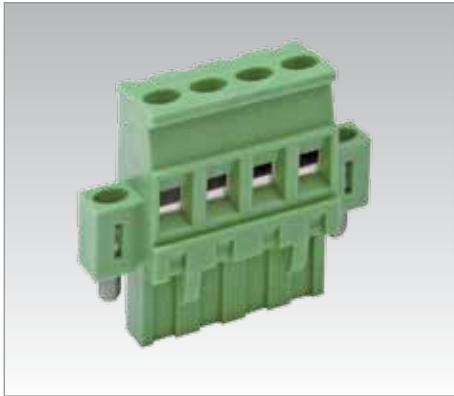

5

5,08

320

20

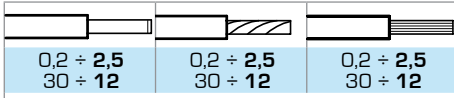

7

0,5

/

5

160

PA - UL 94 V0

M3



0,6 x 3,5

V	A	mm ² /AWG
320	20	0,2 ÷ 2,5
320	20	0,2 ÷ 2,5
300	12	30 ÷ 12

min 2 - max 20

VE

D/B1

Versione
Version

FV V01

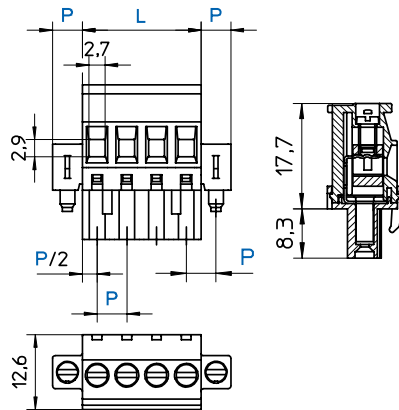

P	L (mm)
5	5 x p
5,08	5,08 x p

MRT3

Blocco unico
Monobloc

Single block
Einzelblock

Poli
Pôles

Poles
Polzahl

2/12



7,62

500

20

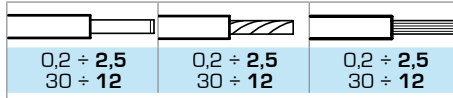

7

0,5

/

5

160

PA - UL 94 V0

M3



0,6 x 3,5

V	A	mm ² /AWG
500	20	0,2 ÷ 2,5
500	20	0,2 ÷ 2,5
300	12	30 ÷ 12

min 2 - max 12

VE

D/B1

Versione
Version

■ ■ ■

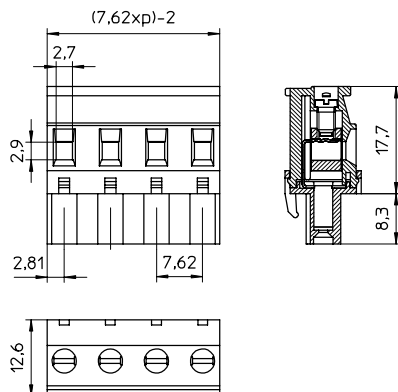

MRT3..V01

Blocco unico
Monobloc

Single block
Einzelblock

Poli
Pôles

Poles
Polzahl

2/12



7,62

500

20

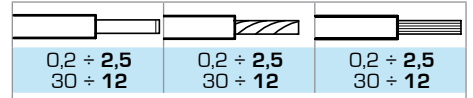

7

0,5

/

5

160

PA - UL 94 V0

M3



0,6 x 3,5

V	A	mm ² /AWG
500	20	0,2 ÷ 2,5
500	20	0,2 ÷ 2,5
300	12	30 ÷ 12

min 2 - max 12

VE

D/B1

Versione
Version

V01

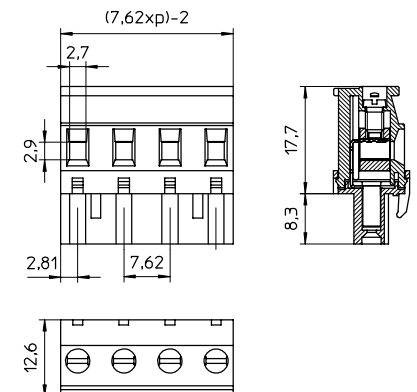

Connettori femmina carrello

Female plug rising clamp

Connecteurs femelle étrier remontant

Steckerteil Liftprinzip

B1

Passo Pas	Pitch Rastermaß	mm
Tensione nominale Tension nominale	Rated Voltage Bemessungsspannung	V
Corrente nominale Intensité nominale	Rated Current Bemessungsstrom	A

Tipo cavi Type du conducteur	Types of cables Leitungstypen	
Sezione nominale Section nominale	Nominal cross section Nennquerschnitt	mm ² AWG
Lunghezza spelatura Longueur de dénudage	Stripping length Abisolierlänge	mm
Coppia di torsione Couple de serrage	Torque Drehmoment	Nm Lb-in
Temperatura Température	Temperature Temperatur	°C
Corpo isolante Corps isolant	Housing Isolierkörper	
Vite imperdibile Vis imperdable	Captive Screw Unverlierbare Schraube	

	IMQ	EN61984
	VDE	EN61984
	cUL	UL1059 + C22.2 n°158

Poli Pôles	Poles Polzahl	X
Colore standard Coloris standard	Standard colour Standardfarbe	Y
Altri dati Autres données	Other information Weitere Informationen	Pag Seite

Ordinazione Référence de commande	How to order Bestellschlüssel				
MRT3 P10 / X	... Y N...				
Tipo Type	Passo Pitch	Poli Poles	Versione Version	Colori Couleurs	Numerazione Marquage
Type	Pas	Pôles	Version	Farben	Bedruckung
Typ	Rastermaß	Polzahl	Version	Farben	Bedruckung

Altri colori a richiesta Autres couleurs sur demande	Other colours on demand Andere Farben bei Bedarf				

MRT3

Blocco unico Monobloc	Single block Einzelblock	
Poli Pôles	Poles Polzahl	2/12



10	10,16
630	
20	

0,2 ÷ 2,5 30 ÷ 12	0,2 ÷ 2,5 30 ÷ 12	0,2 ÷ 2,5 30 ÷ 12
7		
0,5	/	5
160		
PA - UL 94 V0		
M3		
0,6 x 3,5		

V	A	mm ² /AWG
630	20	0,2 ÷ 2,5
630	20	0,2 ÷ 2,5
300	12	30 ÷ 12

min 2 - max 12
VE
D/B1

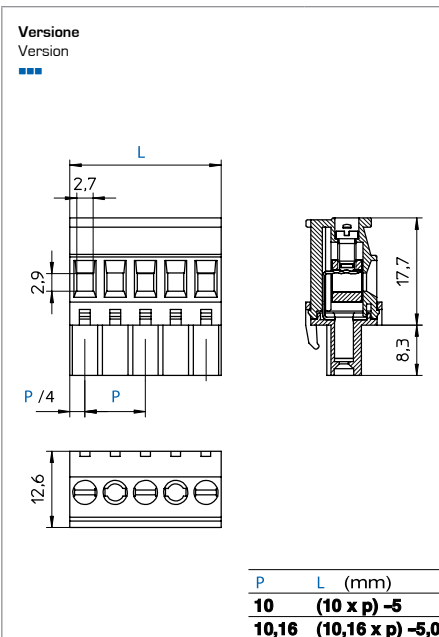

MRT3..FV

Blocco unico Monobloc	Single block Einzelblock	
Poli Pôles	Poles Polzahl	2/10



10	10,16
630	
20	

0,2 ÷ 2,5 30 ÷ 12	0,2 ÷ 2,5 30 ÷ 12	0,2 ÷ 2,5 30 ÷ 12
7		
0,5	/	5
160		
PA - UL 94 V0		
M3		
0,6 x 3,5		

V	A	mm ² /AWG
630	20	0,2 ÷ 2,5
630	20	0,2 ÷ 2,5
300	12	30 ÷ 12

min 2 - max 10
VE
D/B1

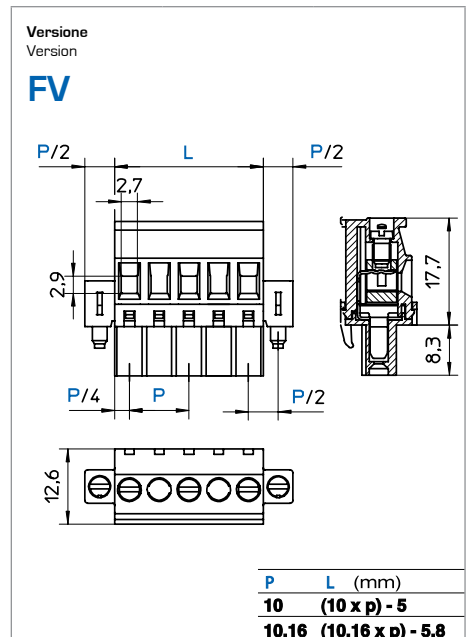

MRT3..VO1

Blocco unico
Monobloc

Single block
Einzelblock

Poli
Pöles

Poles
Polzahl

2/12



10

10,16

630

20

0,2 ÷ 2,5 30 ÷ 12	0,2 ÷ 2,5 30 ÷ 12	0,2 ÷ 2,5 30 ÷ 12

7

0,5

160

PA - UL 94 V0

M3



0,6 x 3,5

V	A	mm ² /AWG
630	20	0,2 ÷ 2,5
630	20	0,2 ÷ 2,5
300	12	30 ÷ 12

min 2 - max 12

VE

D/B1

Versione
Version

VO1

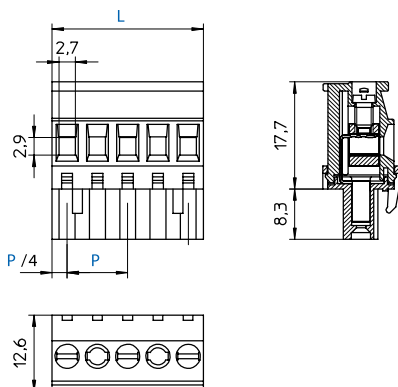

P	L (mm)
10	(10 x p) - 5
10,16	(10,16 x p) - 5,08

MRT3..FV VO1

Blocco unico
Monobloc

Single block
Einzelblock

Poli
Pöles

Poles
Polzahl

2/10

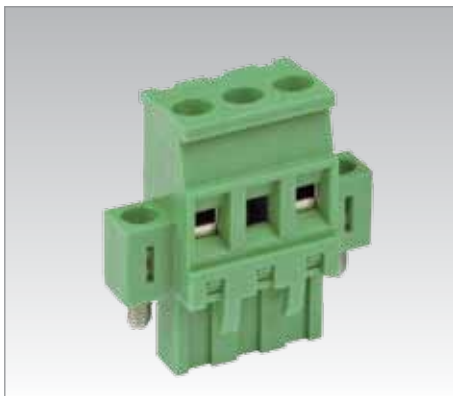

10

10,16

630

20

0,2 ÷ 2,5 30 ÷ 12	0,2 ÷ 2,5 30 ÷ 12	0,2 ÷ 2,5 30 ÷ 12

7

0,5

160

PA - UL 94 V0

M3



0,6 x 3,5

V	A	mm ² /AWG
630	20	0,2 ÷ 2,5
630	20	0,2 ÷ 2,5
300	12	30 ÷ 12

min 2 - max 10

VE

D/B1

Versione
Version

FV VO1

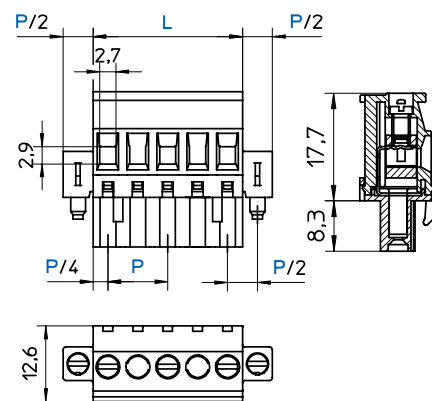

P	L (mm)
10	(10 x p) - 5
10,16	(10,16 x p) - 5,08

B1

Connettori femmina a molla

Screwless female plug

Connecteurs femelle à ressort

Federkraft - Steckerteil



Tranciato
Punched
Découpé
Gestanzt

Pag.	Tipo Type Typ				Tornito Turned Usiné Gedreht	Tranciato Punched Découpé Gestanzt		GWT*	Passo Pitch Pas Rastermaß											
									3,5	3,81	5	5,08	7	7,5	7,62	8,5	10	10,16		
50-51	MRT37	●	●		●	● P	● P	V		●					●					
51-53	MRT30	●	●		●	● P	● P	V				●								●

P = pending

Numerazione a richiesta.
Accessori sezione C.
Tabella di corrispondenza connettori sezione C.

Printing on request.
Accessoires section C.
Connectors correspondance table section C.

Numérotation suivant demande.
Accessoires section C.
Tableau de correspondance des connecteurs section C.

Bedruckung nach Kundenwunsch.
Zubehör Kapitel C.
Steckverbinder Auswahltablelle Kapitel C.

GWT*
● Versione standard compatibile / Standard version compliant / Version standard compatible / Standardversion Kompatibel
V A richiesta / On demand / Sur demande / bei Bedarf

* Vedi dati tecnici / See technical data / cf. données techniques / siehe technische Daten

Connettori femmina molla

Female plug screwless

Connecteurs femelle ressort

Steckerteil Federkraft

MRT37

Blocco unico Monobloc Single block Einzelblock

Poli Poles 2/20



3,81
200
10

0,2 ÷ 1,5 30 ÷ 16	0,2 ÷ 1,5 30 ÷ 16	0,2 ÷ 1,5 30 ÷ 16
8		
160		
PA - UL 94 V0		

V	A	mm ² /AWG
200	10	0,2 ÷ 1,5
300	10	30 ÷ 16

min 2 - max 20
VE
D/B2

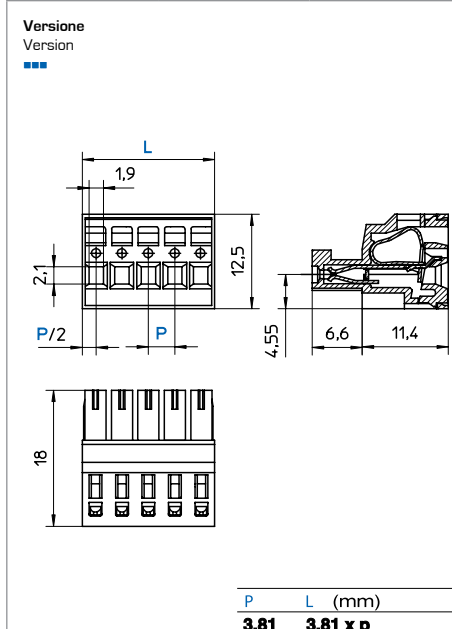

MRT37..FV

Blocco unico Monobloc Single block Einzelblock

Poli Poles 2/20

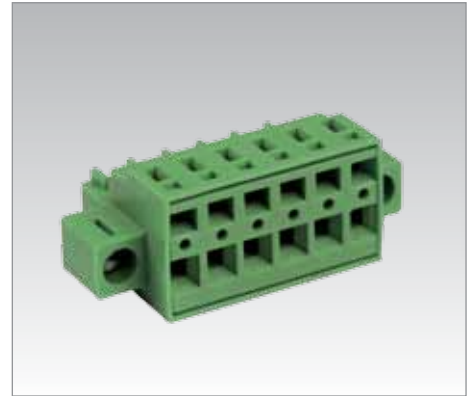

3,81
200
10

0,2 ÷ 1,5 30 ÷ 16	0,2 ÷ 1,5 30 ÷ 16	0,2 ÷ 1,5 30 ÷ 16
8		
160		
PA - UL 94 V0		

V	A	mm ² /AWG
200	10	0,2 ÷ 1,5
300	10	30 ÷ 16

min 2 - max 20
VE
D/B2

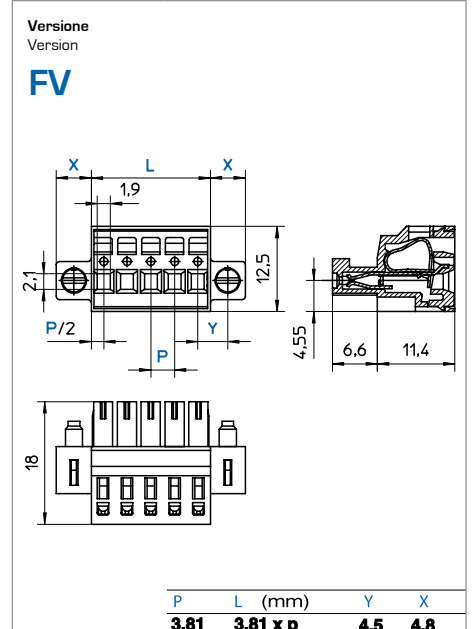

Passo Pas	Pitch Rastermaß	mm
Tensione nominale Tension nominale	Rated Voltage Bemessungsspannung	V
Corrente nominale Intensité nominale	Rated Current Bemessungsstrom	A

Tipo cavi	Types of cables	
Type du conducteur	Leitungstypen	
Sezione nominale Section nominale	Nominal cross section Nennquerschnitt	mm² AWG
Lunghezza spelatura Longueur de dénudage	Stripping length Abisolierlänge	mm

Temperatura Température	Temperature Temperatur	°C
Corpo isolante Corps isolant	Housing Isolierkörper	

	IMQ	EN61984
	VDE	EN61984
	cUL	UL1059 + C22.2 n°158

Poli Pôles	Poles Polzahl	X
Colore standard Coloris standard	Standard colour Standardfarbe	Y
Altri dati Autres données	Other information Weitere Informationen	Pag Seite

Ordinazione	How to order
Référence de commande	Bestellschlüssel
MRT37 P3,81 / X	... Y N...
Tipo	Versione
Passo	Colori
Poli	Numerazione
Pitch	Version
Poles	Colors
Version	Printing
Pôles	Version
Coloris standard	Couleurs
Marquage	Bedruckung
Rastermaß	Polzahl
Version	Farben
Bedruckung	

Altri colori a richiesta	Other colours on demand
Autres couleurs sur demande	Andere Farben bei Bedarf

VE GR NE AR BL RO

MRT37

Blocco unico
Monobloc

Single block
Einzelblock

Poli Póles 2/10

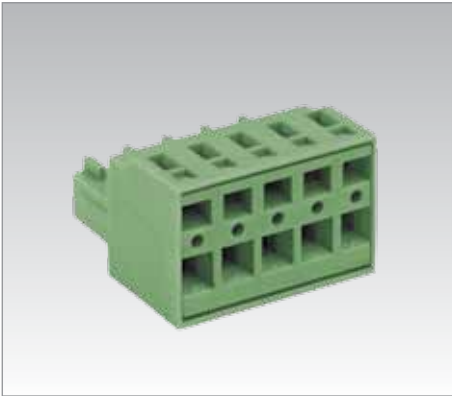

7,62

500

10

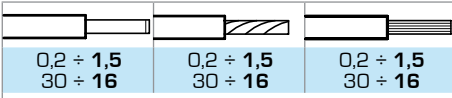

8

160

PA - UL 94 V0

V	A	mm ² /AWG
500	10	0,2 ÷ 1,5
300	10	30 ÷ 16

min 2 - max 10

VE

D/B2

Versione
Version

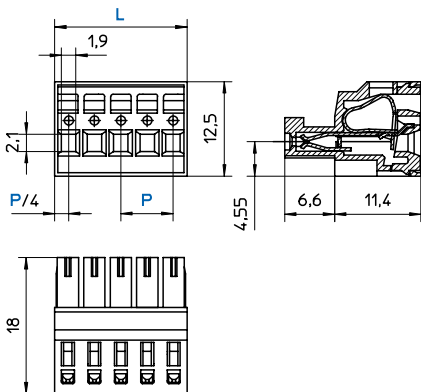

P L (mm)
7,62 (7,62 x p) - 3,81

MRT37..FV

Blocco unico
Monobloc

Single block
Einzelblock

Poli Póles 2/10

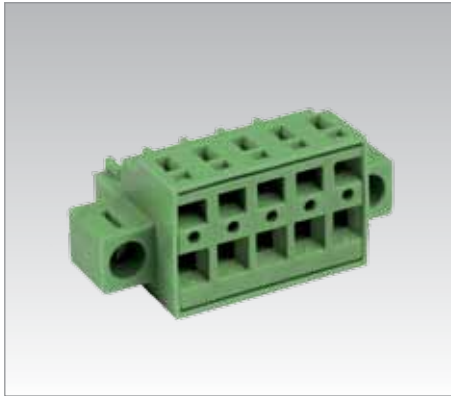

7,62

500

10

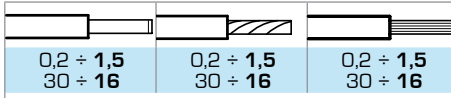

8

160

PA - UL 94 V0

V	A	mm ² /AWG
500	10	0,2 ÷ 1,5
300	10	30 ÷ 16

min 2 - max 10

VE

D/B2

Versione
Version

FV

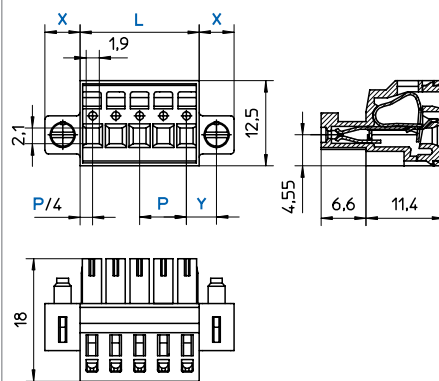

P L (mm) Y X
7,62 (7,62 x p) - 3,81 4,5 4,8

MRT30

Blocco unico
Monobloc

Single block
Einzelblock

Poli Póles 2/24

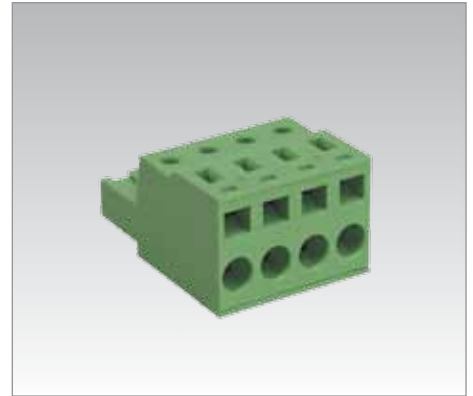

5,08

320

18

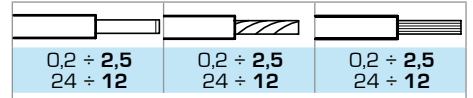

8

160

PA - UL 94 V0

V	A	mm ² /AWG
320	18	0,2 ÷ 2,5
300	14	24 ÷ 12

min 2 - max 24

VE

D/B2

Versione
Version

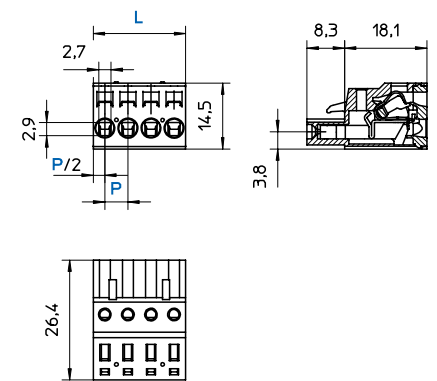

P L (mm)
5,08 5,08 x p

B2

Connettori femmina molla

Female plug screwless

Connecteurs femelle ressort

Steckerteil Federkraft

MRT30..FV

Blocco unico Monobloc	Single block Einzelblock	
Poli Poles	Poles Polzahl	2/20

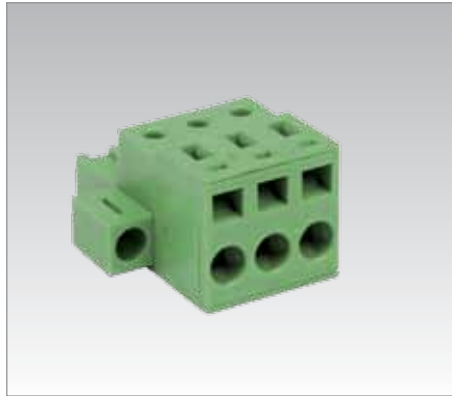

5,08
320
18

0,2 ÷ 2,5 24 ÷ 12	0,2 ÷ 2,5 24 ÷ 12	0,2 ÷ 2,5 24 ÷ 12
8		
160		
PA - UL 94 V0		

V	A	mm²/AWG
320	18	0,2 ÷ 2,5
300	14	24 ÷ 12

min 2 - max 20
VE
D/B2

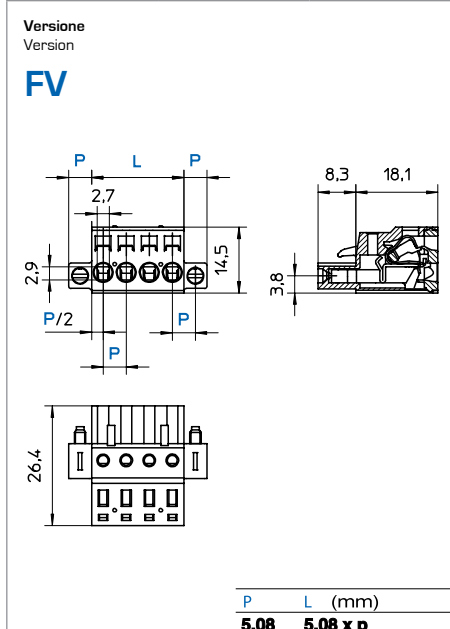

MRT30

Blocco unico Monobloc	Single block Einzelblock	
Poli Poles	Poles Polzahl	2/12

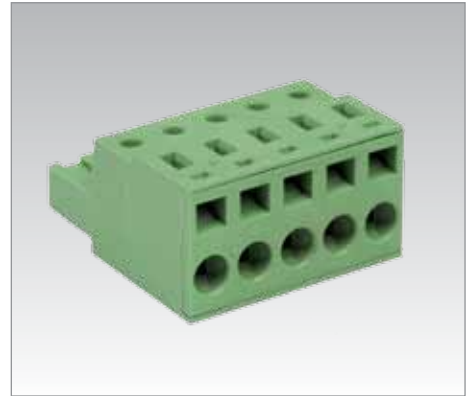

10,16
630
18

0,2 ÷ 2,5 24 ÷ 12	0,2 ÷ 2,5 24 ÷ 12	0,2 ÷ 2,5 24 ÷ 12
8		
160		
PA - UL 94 V0		

V	A	mm²/AWG
630	18	0,2 ÷ 2,5
300	14	24 ÷ 12

min 2 - max 12
VE
D/B2

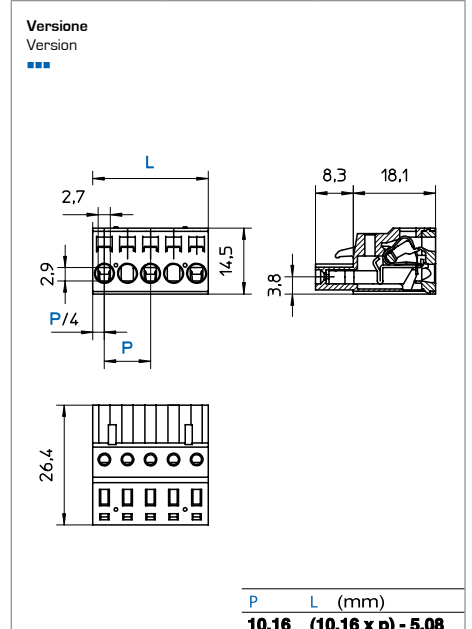

Passo Pas	Pitch Rastermaß	mm
Tensione nominale Tension nominale	Rated Voltage Bemessungsspannung	V
Corrente nominale Intensité nominale	Rated Current Bemessungsstrom	A

Tipo cavi Type du conducteur	Types of cables Leitungstypen	
Sezione nominale Section nominale	Nominal cross section Nennquerschnitt	mm ² AWG
Lunghezza spelatura Longueur de dénudage	Stripping length Abisolierlänge	mm

Temperatura Température	Temperature Temperatur	°C
Corpo isolante Corps isolant	Housing Isolierkörper	

	IMQ	EN61984
	VDE	EN61984
	cUL	UL1059 + C22.2 n°158

Poli Pôles	Poles Polzahl	X
Colore standard Coloris standard	Standard colour Standardfarbe	Y
Altri dati Autres données	Other information Weitere Informationen	Pag Seite

Ordinazione Référence de commande	How to order Bestellschlüssel
MRT30 P5,08 / X	FV Y N...
Tipo	Versione
Passo	Colori
Poli	Numerazione
Versione	Colors
Colori	Printing
Numerazione	Marquage
Versione	Version
Colori	Colors
Marquage	Bedruckung
Version	Version
Colori	Farben
Bedruckung	Bedruckung

Altri colori a richiesta Autres couleurs sur demande	Other colours on demand Andere Farben bei Bedarf
VE GR NE AR BL RO	

MRT30..FV

Blocco unico / Monobloc Single block / Einzelblock

Poli / Póles Poles / Polzahl 2/10



10,16
630
18

0,2 ÷ 2,5 24 ÷ 12	0,2 ÷ 2,5 24 ÷ 12	0,2 ÷ 2,5 24 ÷ 12
8		
160		
PA - UL 94 V0		

V	A	mm ² /AWG
630	18	0,2 ÷ 2,5
300	14	24 ÷ 12

min 2 - max 10
VE
D/B2

Versione / Version

FV

P	L (mm)
10,16	(10,16 x p) - 5,08

B2

Connettori femmina a linguetta





Wire protection female plug

Connecteurs femelle à languette

Drahtschutz-Steckerteil

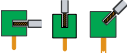

Tornito
Turned
Usiné
Gedreht

Pag.	Tipo Type Type Typ		Tornito Turned Usiné Gedreht	Tranciato Punched Découpé Gestanzt	  	Passo Pitch Pas Rastermaß											
						3,5	3,81	5	5,08	7	7,5	7,62	8,5	10	10,16		
56	CHF	• •	•		•			•							•		

Numerazione a richiesta.

Tabella di corrispondenza connettori sezione C.

Printing on request.

Connectors correspondance table section C.

Numérotation suivant demande.

Tableau de correspondance des connecteurs section C.

Bedruckung nach Kundenwunsch.

Steckverbinder Auswahltablelle Kapitel C.

Connettori femmina linguetta

Female plug wire protection

Connecteurs femelle languette

Steckerteil Drahtschutz

Passo Pas	Pitch Rastermaß	mm
Tensione nominale Tension nominale	Rated Voltage Bemessungsspannung	V
Corrente nominale Intensité nominale	Rated Current Bemessungsstrom	A

Tipo cavi Type du conducteur	Types of cables Leitungstypen	
Sezione nominale Section nominale	Nominal cross section Nennquerschnitt	mm ² AWG
Lunghezza spelatura Longueur de dénudage	Stripping length Abisolierlänge	mm
Coppia di torsione Couple de serrage	Torque Drehmoment	Nm Lb-in
Temperatura Température	Temperature Temperatur	°C
Corpo isolante Corps isolant	Housing Isolierkörper	
Vite imperdibile Vis imperdable	Captive Screw Unverlierbare Schraube	

	IMQ	EN61984
	VDE	EN61984
	cUL	UL1059 + C22.2 n°158

Poli Pôles	Poles Polzahl	X
Colore standard Coloris standard	Standard colour Standardfarbe	Y
Altri dati Autres données	Other information Weitere Informationen	Pag Seite

Ordinazione Référence de commande	How to order Bestellschlüssel				
CHF 5 / X ... Y N...					
Tipo Type	Passo Pitch	Poli Poles	Versione Version	Colori Couleurs	Numerazione Marquage
Type	Pas	Pôles	Version	Farben	Bedruckung
Typ	Rastermaß	Polzahl	Version	Farben	Bedruckung

Altri colori a richiesta Autres couleurs sur demande	Other colours on demand Andere Farben bei Bedarf				

CHF

Modulo componibile
Elements modulaires

Interlocking modules
Zusammensteckbare Blöcke

Poli
Pôles

Poles
Polzahl

2/3



5
250
10

0,5 ÷ 1,5 30 ÷ 16	0,5 ÷ 1,5 30 ÷ 16	0,5 ÷ 1,5 30 ÷ 16
6		
0,4	/	3
110		
PA - UL 94 V0		
M2,5		
	0,6 x 3,5	

V	A	mm²/AWG
300	6	30 ÷ 16

min 2 - max ...
NE
D/B3

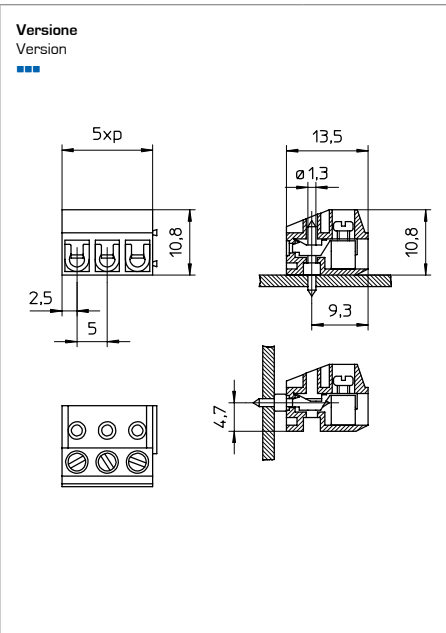

CHF

Modulo componibile
Elements modulaires

Interlocking modules
Zusammensteckbare Blöcke

Poli
Pôles

Poles
Polzahl

1/2



10
630
10

0,5 ÷ 1,5 30 ÷ 16	0,5 ÷ 1,5 30 ÷ 16	0,5 ÷ 1,5 30 ÷ 16
6		
0,4	/	3
110		
PA - UL 94 V0		
M2,5		
	0,6 x 3,5	

V	A	mm²/AWG
300	6	30 ÷ 16

min 2 - max ...
NE
D/B3

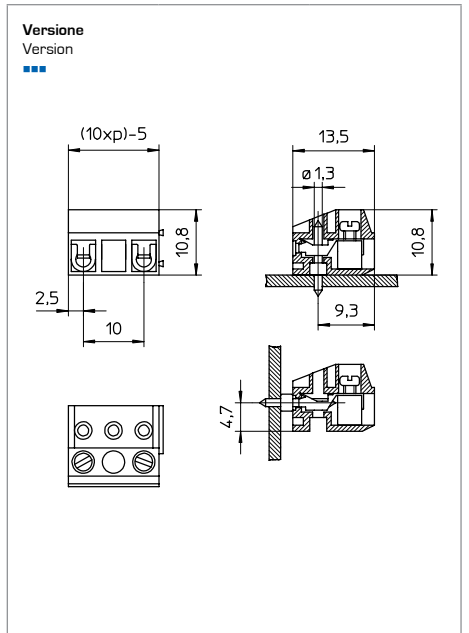

Connettori maschio per C.S.

Headers for P.C.B.

Connecteurs mâle pour CI

Stiftleiste für Leiterplatten



Tranciato
Punched
Découpé
Gestanzt

Pag.	Tipo Type Type				Tornito Turned Usiné Gedreht	Tranciato Punched Découpé Gestanzt		GWT*	THR*	Passo Pitch Pas Rastermaß											
										3,5	3,81	5	5,08	7	7,5	7,62	8,5	10	10,16		
58-59	MRT9	•	•		•	• P	•	V	V	•	•			•		•					
59-60	MRT33	•	•		•		•				•					•					
60	CHM		•		•		•					•								•	
61	CUM		•		•	•	•	•	V			•								•	
61-64	CPM	•	•		•	•	•	•	V	V		•	•		•	•				•	•
64-65	MRT21	•	•		•	•	•	•	V			•	•							•	•

P = pending

Accessori sezione C.

Tabella di corrispondenza connettori sezione C.

Accessories section C.

Connectors correspondance table section C.

Accessoires section C.

Tableau de correspondance des connecteurs section C.

Zubehör Kapitel C.

Steckverbinder Auswahltablelle Kapitel C.

GWT*

• **Versione standard compatibile / Standard version compliant** / Version standard compatible / Standardversion Kompatibel
V A richiesta / On demand / Sur demande / bei Bedarf

THR*

V A richiesta / On demand / Sur demande / bei Bedarf

* Vedi dati tecnici / See technical data / cf. données techniques / siehe technische Daten

Connettori maschio per C.S.

Headers for P.C.B.

Connecteurs mâle pour C.I.

Stiftleiste für Leiterplatten

MRT9 MRT9..SQ

Blocco unico Monobloc Single block Einzelblock

Poli Poles 2/20

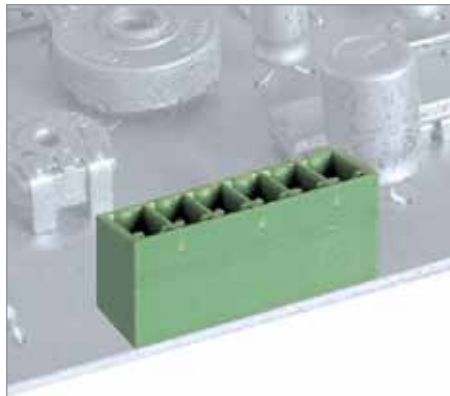

3,5 3,81

200
10

110
PA - UL 94 VO

V	A	mm ² /AWG
200	10	0,2 ÷ 1,0
300	8	30 ÷ 16

min 2 - max 20
VE
D/B4

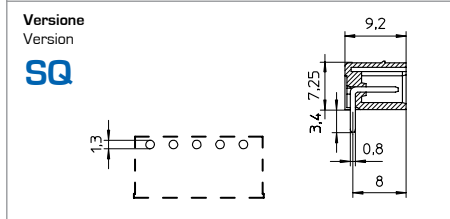
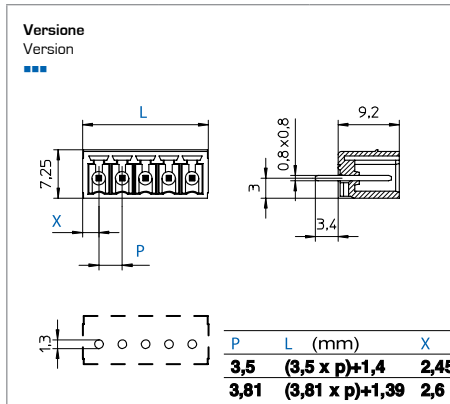

MRT9..FV MRT9..SQ FV

Blocco unico Monobloc Single block Einzelblock

Poli Poles 2/20

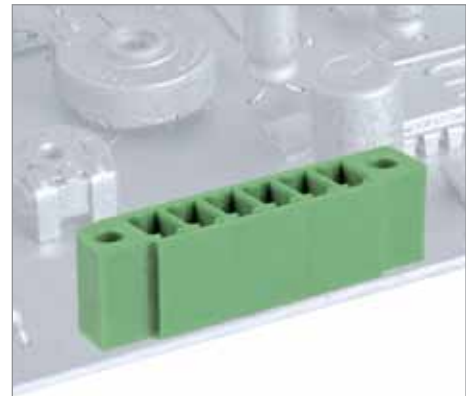

3,5 3,81

200
10

110
PA - UL 94 VO

V	A	mm ² /AWG
200	10	0,2 ÷ 1,0
300	8	30 ÷ 16

min 2 - max 20
VE
D/B4

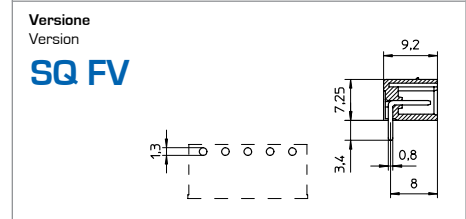
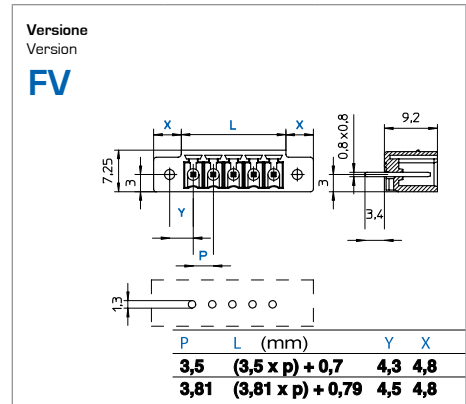

Passo Pas	Pitch Rastermaß	mm
Tensione nominale Tension nominale	Rated Voltage Bemessungsspannung	V
Corrente nominale Intensité nominale	Rated Current Bemessungsstrom	A
Temperatura Température	Temperature Temperatur	°C
Corpo isolante Corps isolant	Housing Isolierkörper	

	IMQ	EN61984
	VDE	EN61984
	cUL	UL1059 + C22.2 n°158

Poli Pôles	Poles Polzahl	X
Colore standard Coloris standard	Standard colour Standardfarbe	Y
Altri dati Autres données	Other information Weitere Informationen	Pag Seite

Ordinazione Référence de commande	How to order Bestellschlüssel
MRT9 P3,5 / X	SQ Y N...
Tipo Type	Passo Pitch
Poli Poles	Versione Version
Colori Colors	Standard color Standardfarbe
Numerazione Printing	Version Version
Colori Colors	Standard color Standardfarbe
Marquage	Version Version
Bedruckung	Version Version

Altri colori a richiesta / Autres couleurs sur demande / Other colours on demand / Andere Farben bei Bedarf

VE GR NE AR BL RO

B4

MRT9

MRT9..SQ

Blocco unico
Monobloc

Single block
Einzelblock

Poli
Pöles

Poles
Polzahl

2/10

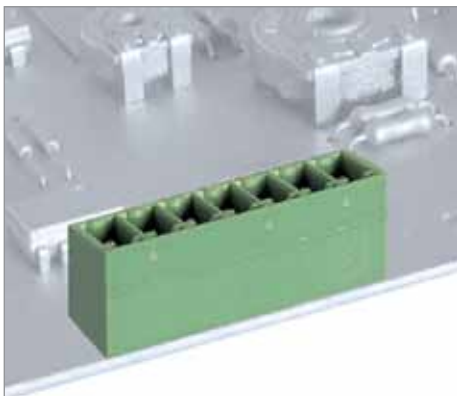

7 7,62

400 500

10

110

PA - UL 94 V0

V	A	mm ² /AWG
400 (7)	500 (7.62)	10
300	8	30 ÷ 16

min 2 - max 10

VE

D/B4

Versione
Version

■ ■ ■

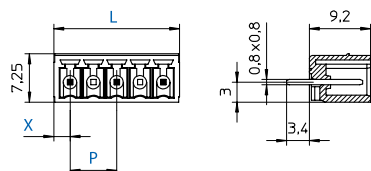

P	L (mm)	X
7	(7 x p)-2,1	2,45
7,62	(7,62 x p)-2,42	2,6

Versione
Version

SQ

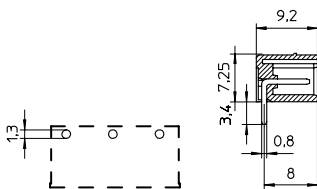

MRT9..FV

MRT9..SQ FV

Blocco unico
Monobloc

Single block
Einzelblock

Poli
Pöles

Poles
Polzahl

2/10



7 7,62

400 500

10

110

PA - UL 94 V0

V	A	mm ² /AWG
400 (7)	500 (7.62)	10
300	8	30 ÷ 16

min 2 - max 10

VE

D/B4

Versione
Version

FV

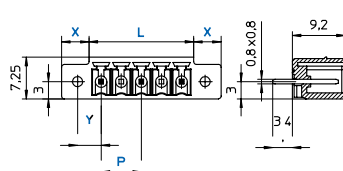

P	L (mm)	Y	X
7	(7 x p) - 2,8	4,3	4,8
7,62	(7,62 x p) - 3,02	4,5	4,8

Versione
Version

SQ FV

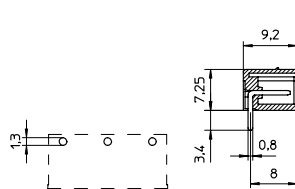

MRT33

MRT33..SQ

Blocco unico
Monobloc

Single block
Einzelblock

Poli
Pöles

Poles
Polzahl

2/12



3,81

200

10

110

PA - UL 94 V0

V	A	mm ² /AWG
300	8	30 ÷ 16

min 2 - max 12

VE

D/B4

Versione
Version

■ ■ ■

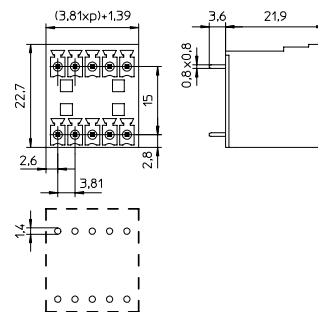

Versione
Version

SQ

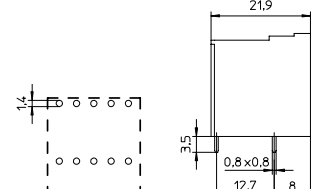

B4

Connettori maschio per C.S.

Headers for P.C.B.

Connecteurs mâle pour C.I.

Stiftleiste für Leiterplatten

Passo Pas	Pitch Rastermaß	mm
Tensione nominale Tension nominale	Rated Voltage Bemessungsspannung	V
Corrente nominale Intensité nominale	Rated Current Bemessungsstrom	A

Temperatura Température	Temperature Temperatur	°C
Corpo isolante Corps isolant	Housing Isolierkörper	

	IMQ	EN61984
	VDE	EN61984
	cUL	UL1059 + C22.2 n°158

Poli Pôles	Poles Polzahl	X
Colore standard Coloris standard	Standard colour Standardfarbe	Y
Altri dati Autres données	Other information Weitere Informationen	Pag Seite

Ordinazione Référence de commande		How to order Bestellschlüssel		
MRT33 P7,62 / X	...	Y	N...	
Tipo	Passo	Poli	Versione	Colori
Type	Pitch	Poles	Version	Colors
Type	Pas	Pôles	Version	Couleurs
Type	Rastermaß	Polzahl	Version	Farben
				Bedruckung

Altri colori a richiesta Autres couleurs sur demande	Other colours on demand Andere Farben bei Bedarf

MRT33 MRT33..SQ

Blocco unico Monobloc Single block Einzelblock

Poli Poles 2/6
Pôles Polzahl



7,62
500
10

110
PA - UL 94 V0

V	A	mm²/AWG
300	8	30 ÷ 16

min 2 - max 6
VE
D/B4

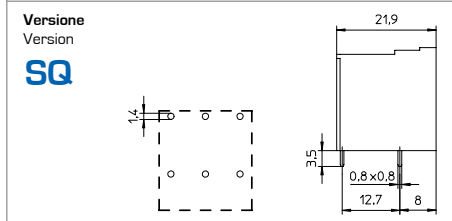
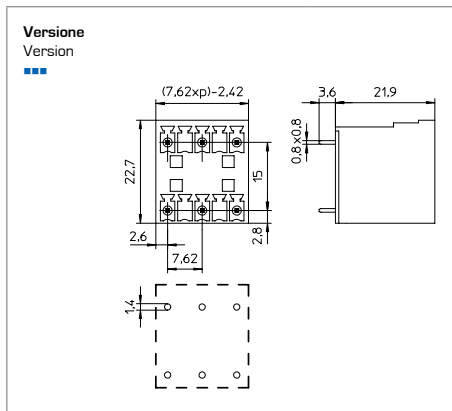

CHM

Blocco unico Monobloc Single block Einzelblock

Poli Poles 2/24 (5)
Pôles Polzahl 2/12 (10)



5	10
250	630
10	

110
PA - UL 94 V0

V	A	mm²/AWG
300	6	30 ÷ 16

min 2 - max ...
VE
D/B4

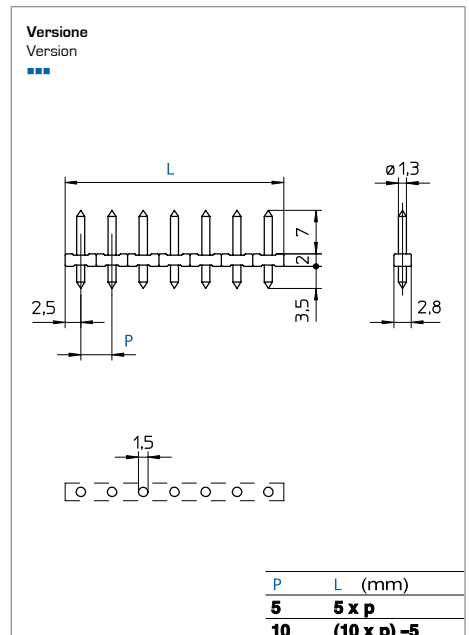

B4

CUM

Blocco unico
Monobloc

Single block
Einzelblock

Poli Poles 2/36 (5)
Poles Polzahl 2/18 (10)

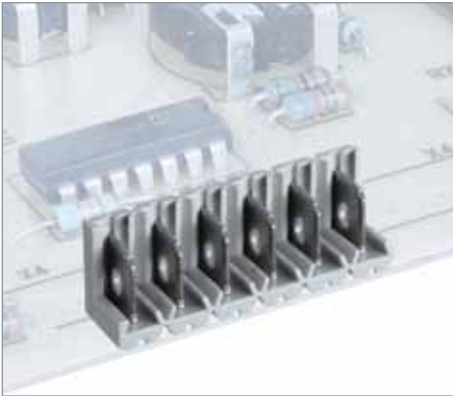

5	10
250	500
16	

130	
PC - UL 94 V0	

V	A	mm ² /AWG
250 (5)	500 (10)	16
250 (5)	500 (10)	16
300	14	24 ÷ 12

min 2 - max ...	
VE	
D/B4	

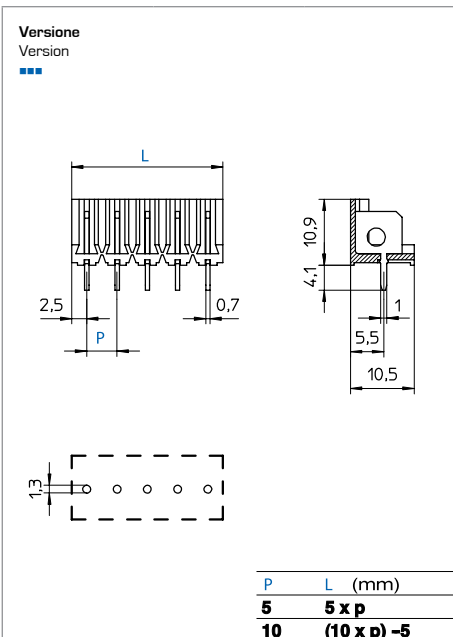

CPM

Blocco unico
Monobloc

Single block
Einzelblock

Poli Poles 2/24

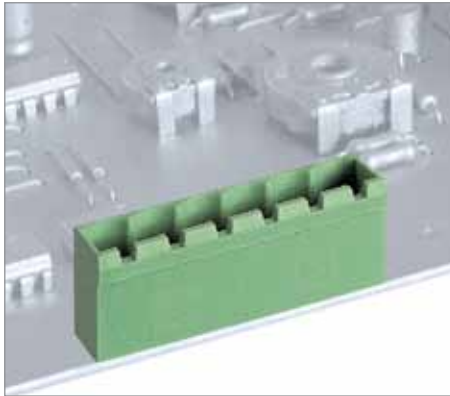

5	5,08
320	
20	

160	
PA - UL 94 V0	

V	A	mm ² /AWG
320	20	0,2 ÷ 2,5
320	20	0,2 ÷ 2,5
300	12	24 ÷ 12

min 2 - max 24	
VE	
D/B4	

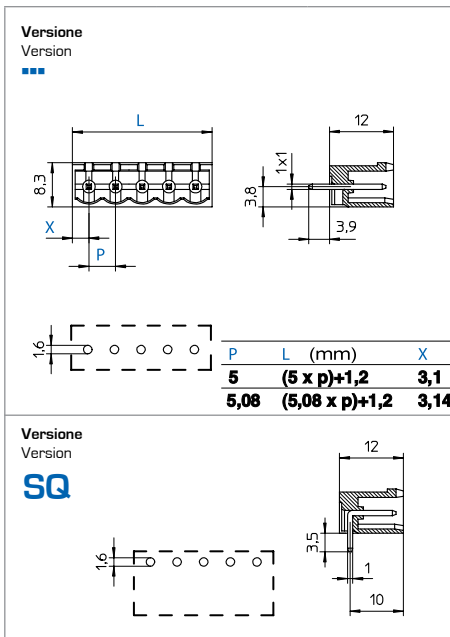

CPM..A

Blocco unico
Monobloc

Single block
Einzelblock

Poli Poles 2/24

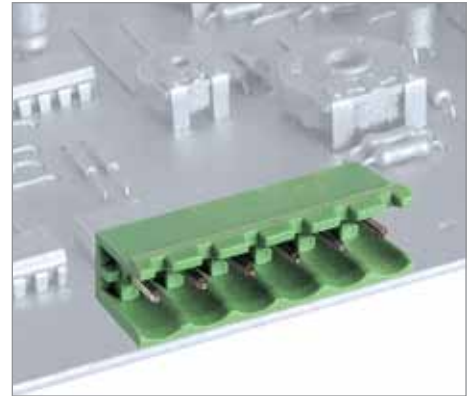

5	5,08
320	
20	

160	
PA - UL 94 V0	

V	A	mm ² /AWG
320	20	0,2 ÷ 2,5
320	20	0,2 ÷ 2,5
300	12	24 ÷ 12

min 2 - max 24	
VE	
D/B4	

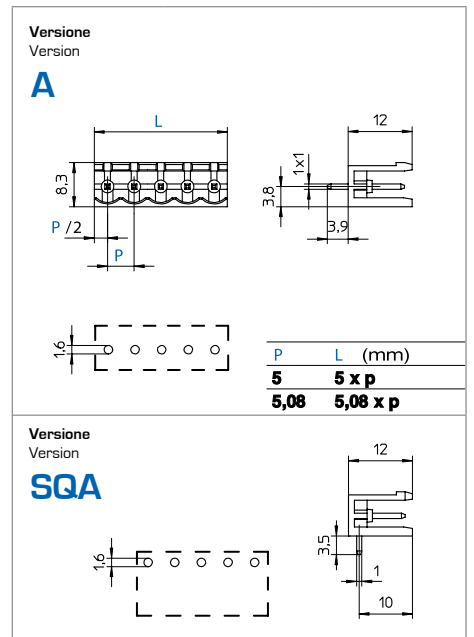

B4

Connettori maschio per C.S.

Headers for P.C.B.

Connecteurs mâle pour C.I.

Stiftleiste für Leiterplatten

CPM..FV CPM..SQFV

Blocco unico Monobloc Single block Einzelblock

Poli Poles 2/20



5	5,08
320	
20	

160
PA - UL 94 VO

V	A	mm ² /AWG
320	20	0,2 ÷ 2,5
320	20	0,2 ÷ 2,5
300	12	24 ÷ 12

min 2 - max 20
VE
D/B4

Versione Version

FV

P	L (mm)	X
5	(5 x p) + 0,2	4,9
5,08	(5,08 x p) + 0,2	4,98

Versione Version

SQ FV

CPM CPM..SQ

Blocco unico Monobloc Single block Einzelblock

Poli Poles 2/12

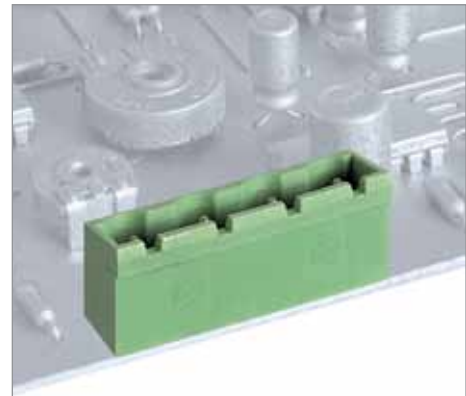

7,5	7,62
500	
20	

160
PA - UL 94 VO

V	A	mm ² /AWG
500	20	0,2 ÷ 2,5
500	20	0,2 ÷ 2,5
300	12	24 ÷ 12

min 2 - max 12
VE
D/B4

Versione Version

SQ

P	L (mm)	X
7,5	7,5 x p	
7,62	7,62 x p	

Versione Version

SQ

Passo Pas	Pitch Rastermaß	mm
Tensione nominale Tension nominale	Rated Voltage Bemessungsspannung	V
Corrente nominale Intensité nominale	Rated Current Bemessungsstrom	A

Temperatura Température	Temperature Temperatur	°C
Corpo isolante Corps isolant	Housing Isolierkörper	

	IMQ	EN61984
	VDE	EN61984
	cUL	UL1059 + C22.2 n°158

Poli Pôles	Poles Polzahl	X
Colore standard Coloris standard	Standard colour Standardfarbe	Y
Altri dati Autres données	Other information Weitere Informationen	Pag Seite

Ordinazione Référence de commande

How to order Bestellschlüssel

CPM 5 / X FV Y N...

Tipo	Passo	Poli	Versione	Colori	Numerazione
Type	Pitch	Poles	Version	Colors	Printing
Type	Pas	Pôles	Version	Couleurs	Marquage
Type	Rastermaß	Polzahl	Version	Farben	Bedruckung

Altri colori a richiesta
Autres couleurs sur demande

Other colours on demand
Andere Farben bei Bedarf

VE GR NE AR BL RO

B4

CPM..A

CPM..SQA

Blocco unico
Monobloc

Single block
Einzelblock

Poli
Pöles

Poles
Polzahl

2/12

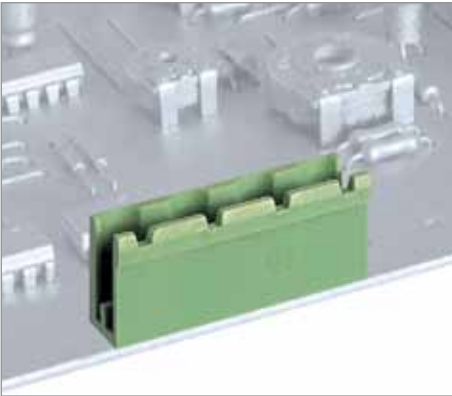

7,5	7,62
500	
20	

160	
PA - UL 94 V0	

V	A	mm ² /AWG
500	20	0,2 ÷ 2,5
500	20	0,2 ÷ 2,5
300	12	24 ÷ 12

min 2 - max 12	
VE	
D/B4	

Versione
Version

A

P	L (mm)	X
7,5	(7,5 x p)-2	2,75
7,62	(7,62 x p)-2	2,81

Versione
Version

SQA

CPM

CPM..SQ

Blocco unico
Monobloc

Single block
Einzelblock

Poli
Pöles

Poles
Polzahl

2/12

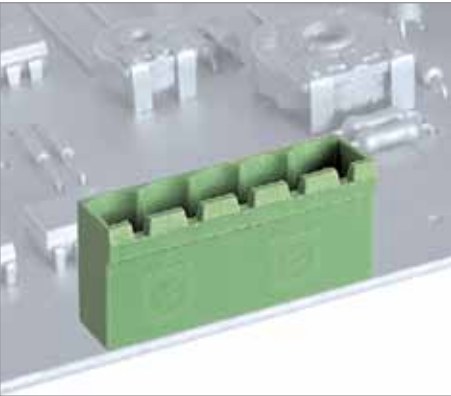

10	10,16
630	
20	

160	
PA - UL 94 V0	

V	A	mm ² /AWG
630	20	0,2 ÷ 2,5
630	20	0,2 ÷ 2,5
300	12	24 ÷ 12

min 2 - max 12	
VE	
D/B4	

Versione
Version

SQ

P	L (mm)	X
10	(10 x p)-3,8	3,1
10,16	(10,16 x p)-3,88	3,14

Versione
Version

SQA

CPM..A

CPM..SQA

Blocco unico
Monobloc

Single block
Einzelblock

Poli
Pöles

Poles
Polzahl

2/12

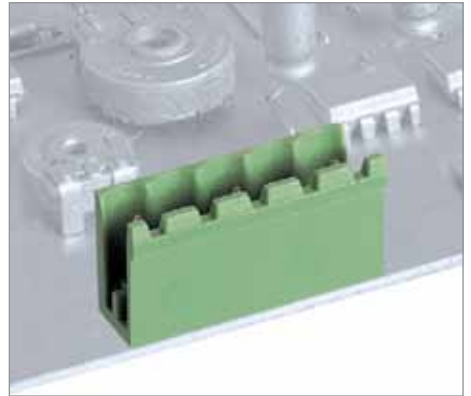

10	10,16
630	
20	

160	
PA - UL 94 V0	

V	A	mm ² /AWG
630	20	0,2 ÷ 2,5
630	20	0,2 ÷ 2,5
300	12	24 ÷ 12

min 2 - max 12	
VE	
D/B4	

Versione
Version

A

P	L (mm)	X
10	(10 x p)-5	
10,16	(10,16 x p)-5,08	

Versione
Version

SQA

B4

Connettori maschio per C.S.

Headers for P.C.B.

Connecteurs mâle pour C.I.

Stiftleiste für Leiterplatten

CPM..FV CPM..SQFV

Blocco unico Monobloc Single block Einzelblock

Poli Poles 2/10

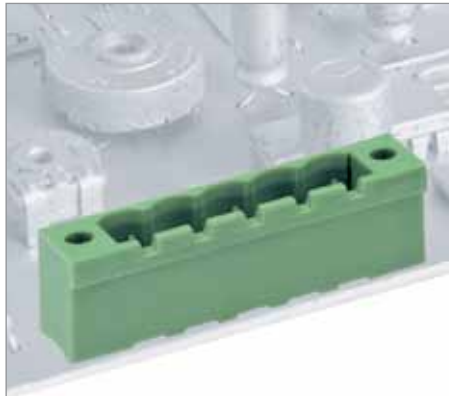

10	10,16
630	
20	

160	PA - UL 94 V0
-----	---------------

V	A	mm ² /AWG
630	20	0,2 ÷ 2,5
630	20	0,2 ÷ 2,5
300	12	24 ÷ 12

min 2 - max 10
VE
D/B4

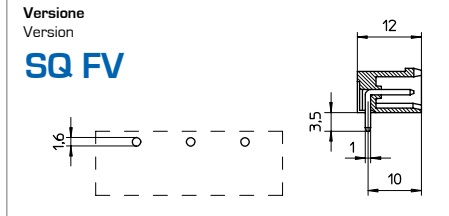
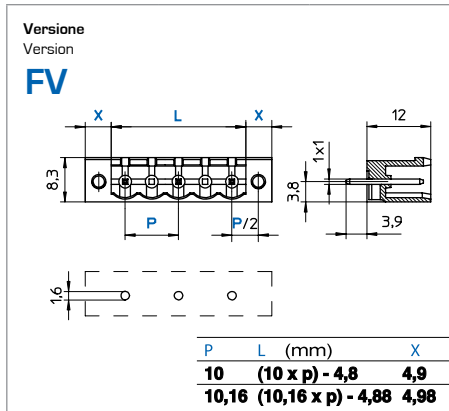

MRT21 MRT21..SQ

Modulo componibile Elements modulaires Interlocking modules Zusammensteckbare Blöcke

Poli Poles 2/3

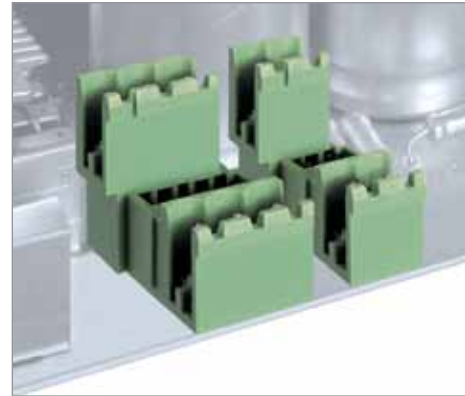

5
320
20

160	PA - UL 94 V0
-----	---------------

V	A	mm ² /AWG
320	20	0,2 ÷ 2,5
320	20	0,2 ÷ 2,5
300	12	30 ÷ 12

min 2 - max ...
VE
D/B4

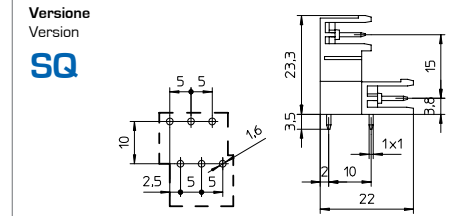
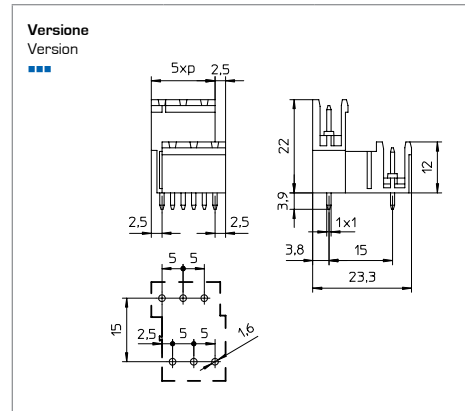

Passo Pas	Pitch Rastermaß	mm
Tensione nominale Tension nominale	Rated Voltage Bemessungsspannung	V
Corrente nominale Intensité nominale	Rated Current Bemessungsstrom	A
Temperatura Température	Temperature Temperatur	°C
Corpo isolante Corps isolant	Housing Isolierkörper	

IMQ	EN61984
VDE	EN61984
cUL	UL1059 + C22.2 n°158

Poli Poles	Poles Polzahl	X
Colore standard Coloris standard	Standard colour Standardfarbe	Y
Altri dati Autres données	Other information Weitere Informationen	Pag Seite

Ordinazione Référence de commande

How to order Bestellschlüssel

CPM 10 / X FV Y N...

Tipo Type	Passo Pitch	Poli Poles	Versione Version	Colori Colors	Numerazione Printing
Type	Pas	Pôles	Version	Couleurs	Marquage
Typ	Rastermaß	Polzahl	Version	Farben	Bedruckung

Altri colori a richiesta Autres couleurs sur demande

Other colours on demand Andere Farben bei Bedarf

VE GR NE AR BL RO

B4

MRT21

MRT21..SQ

Modulo componibile
Elements modulaires

Interlocking modules
Zusammensteckbare Blöcke

Poli
Pôles

Poles
Polzahl

2/3

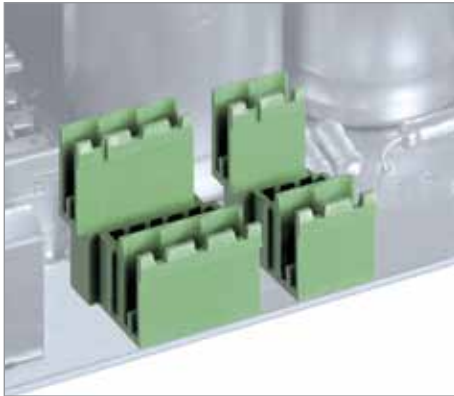

5,08

320

20

160

PA - UL 94 V0

V	A	mm ² /AWG
320	20	0,2 ÷ 2,5
320	20	0,2 ÷ 2,5
300	12	30 ÷ 12

min 2 - max ...

VE

D/B4

Versione
Version

■ ■ ■

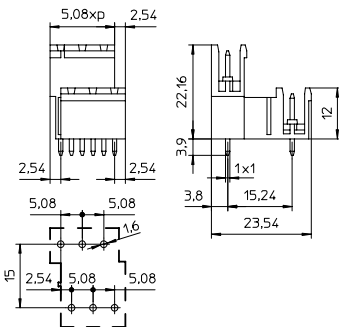

Versione
Version

SQ

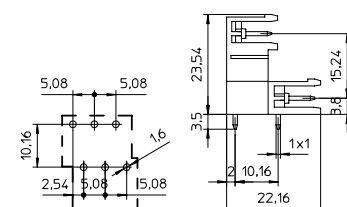

MRT21

MRT21..SQ

Modulo componibile
Elements modulaires

Interlocking modules
Zusammensteckbare Blöcke

Poli
Pôles

Poles
Polzahl

1/2

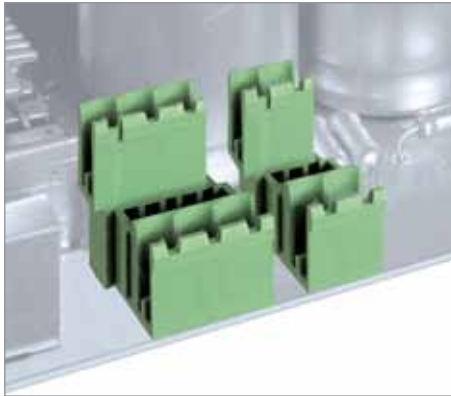

10

630

20

160

PA - UL 94 V0

V	A	mm ² /AWG
630	20	0,2 ÷ 2,5
630	20	0,2 ÷ 2,5
300	12	30 ÷ 12

min 2 - max ...

VE

D/B4

Versione
Version

■ ■ ■

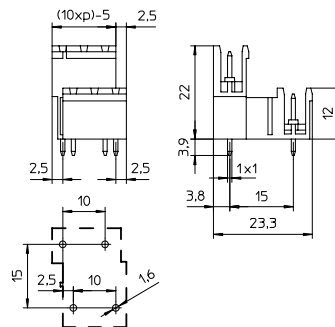

Versione
Version

SQ

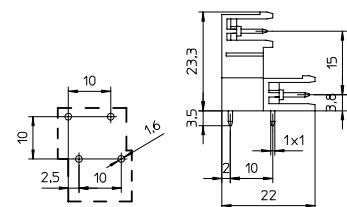

MRT21

MRT21..SQ

Modulo componibile
Elements modulaires

Interlocking modules
Zusammensteckbare Blöcke

Poli
Pôles

Poles
Polzahl

1/2

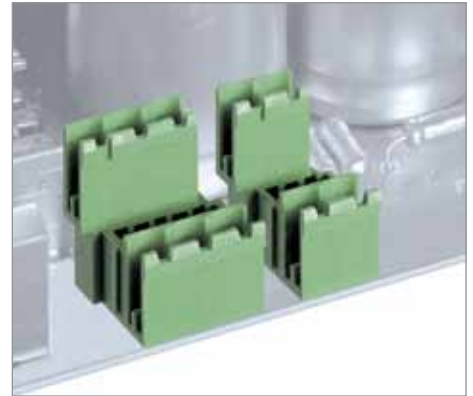

10,16

630

20

160

PA - UL 94 V0

V	A	mm ² /AWG
630	20	0,2 ÷ 2,5
630	20	0,2 ÷ 2,5
300	12	30 ÷ 12

min 2 - max ...

VE

D/B4

Versione
Version

■ ■ ■

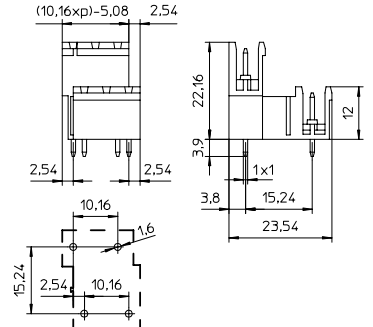

Versione
Version

SQ

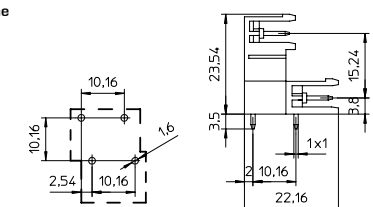

B4

**Polarizzatori
per connettori**

**Coding keys
for connectors**

**Détrompeurs
pour connecteurs**

**Codierteile
für Steckverbinder**

BS391AR



BS392AR

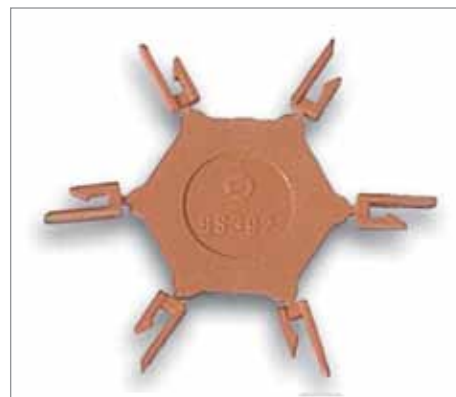

BS224/1NE







BS224/2MA

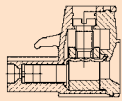
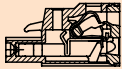
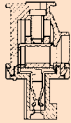

Tabella di corrispondenza dei polarizzatori
Tableau de correspondance des détrompeurs

Coding keys correspondence table
Codierteile Auswahltable

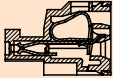
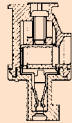
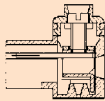
	CUM	MRT9	CPF	MRT3	MRT30	CPM	MRT21
BS391AR		•	•	•	•		
BS392AR						•	•
BS224/1NE	•						
BS224/2MA	•						

	CPF	MRT30	MRT3	MRT8	MRT37	MRT22	CUF	CHF
								

CPM

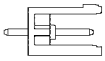

-
-
-

CPM/SQ

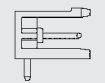

-
-
-

MRT21

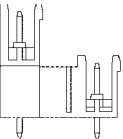

-
-
-

MRT9

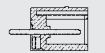

-
-
-

MRT9/SQ

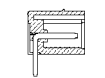

-
-
-

CUM

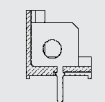

-

CHM

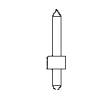







-

Nuovi prodotti in fase di sviluppo

New products under development

En cours de développement

Neuprodukte in Entwicklung

	Tipo Type Type Typ	Passo (mm) Pitch (mm) Pas (mm) Rastermaß (mm)	Poli Poles Pôles Polzahl
MRT38 	Femmina a molla Screwless female plug Femelle à ressort Federkraft-Steckerteil	3,81 7,62	2 - 20 2 - 10
MRT38 FV 	Femmina a molla Screwless female plug Femelle à ressort Federkraft-Steckerteil	3,81 7,62	2 - 20 2 - 10
MRT39 	Femmina a molla Screwless female plug Femelle à ressort Federkraft-Steckerteil	5,08 10,16	2 - 20 2 - 10
MRT39 FV 	Femmina a molla Screwless female plug Femelle à ressort Federkraft-Steckerteil	5,08 10,16	2 - 20 2 - 10
MRT40 	Maschio volante a molla Screwless male plug Mâle volant à ressort Federkraft-Steckerteil invertiert (Stiftkontakt)	5,08 10,16	2 - 16 2 - 8
MRT40 A 	Maschio volante a molla Screwless male plug Mâle volant à ressort Federkraft-Steckerteil invertiert (Stiftkontakt)	5,08 10,16	2 - 16 2 - 8
MRT40 FV 	Maschio volante a molla Screwless male plug Mâle volant à ressort Federkraft-Steckerteil invertiert (Stiftkontakt)	5,08 10,16	2 - 16 2 - 8

C

SK presta una particolare attenzione alle necessità degli utilizzatori rendendo disponibili prodotti e soluzioni design-in. Di seguito riportiamo alcuni esempi:

- diversi colori dei corpi plastici;
- identificazione di ogni singola via mediante stampigliatura/ numerazione;
- configurazioni a disegno;
- variazioni geometriche non fondamentali del corpo plastico;
- polarizzazione dei connettori;
- altro...

SK è, inoltre, strutturata per poter realizzare soluzioni custom per soddisfare le diverse esigenze dei propri clienti.

SK est un Groupe très attentif aux exigences de ses clients et des utilisateurs finaux mettant à disposition des produits et des solutions «design-in» aux produits standards; quelques exemples:

- différentes couleurs des corps isolants;
- identification de chaque pôle par numérotation;
- configuration selon dessin technique;
- variations géométriques non essentielles du corps isolant;
- détrompeurs;
- etc...

De plus, toujours dans la volonté de répondre aux exigences de ses clients, SK est à même de répondre à toute demande de développement spécifique ou adaptation custom.

SK pays particular attention to the user's needs, making design-in products. Here some examples:

- different colors of plastic housing;
- identification of each single pole through markings/ printing;
- custom configurations;
- non-fundamental geometric variations of the plastic housing;
- connector polarization (coding key);
- other...

Moreover, SK is able to develop custom solutions satisfying any customer needs.

SK richtet seine Aufmerksamkeit auf die Bedürfnisse der Benutzer, indem sie design-in Produkte und Lösungen anbietet. Nachfolgend einige Beispiele:

- verschiedene Farben der Steckverbinder-u. Klemmgehäuse;
- Identifikation der einzelnen Anschlussstellen durch Nummerierung/Aufdruck;
- Kundenspezifische Konfiguration;
- Modifikationen an den Plastikgehäusen;
- Kodierung der Steckverbinder (Kodierteile);
- Anderes

Desweiteren ist SK darauf eingerichtet die verschiedensten Kundenspezifischen Lösungen zu realisieren.

Dati tecnici

Technical data

Données techniques

Technische Daten

D

D

**IEC 60335-1
SICUREZZA DEGLI APPARECCHI ELETTRICI AD
USO DOMESTICO E SIMILARE**

La Norma tratta le prescrizioni per la sicurezza degli apparecchi elettrici ad uso domestico e similare, con tensione nominale non superiore a 250 Volt per apparecchi monofase e 480 Volt per gli altri apparecchi.

Recentemente la Normativa è stata modificata e resa più esigente per evitare i rischi di incendio e per dare ulteriore garanzia e sicurezza alle apparecchiature elettriche. Le modifiche riguardano soprattutto le parti in materiale isolante che portano connessioni elettriche con passaggio di corrente >0,2A, ivi compreso le parti a meno di 3mm di distanza dalla connessione.

Il flusso per la valutazione dell'idoneità del materiale e/o pezzo alla IEC 60335-1 è schematizzato in figura.

**IEC 60335-1
SECURITE DES APPAREILS ELECTRIQUES A
USAGE DOMESTIQUE ET SIMILAIRE**

La norme traite des prescriptions pour la sécurité des appareils électriques à usage domestique et similaire, dont la tension nominale ne dépasse pas 250 Volts pour les appareils monophasés et 480 Volts pour les autres appareils .

Récemment la Normative a été modifiée et rendue plus exigeante tant pour éviter les risques d'incendie que pour apporter une garantie supplémentaire ainsi qu'une sécurité accrue aux appareillages électriques.

Les modifications touchent principalement les parties en matériau isolant au contact de connexions électriques ayant un courant de passage de 0,2A ainsi que les parties situées à moins de 3mm de distance de la connexion.

Le synoptique d'aptitude du matériau et/ou pièce à l'IEC 60335-1 est schématisé selon la figure ci-dessous.

**IEC 60335-1
SAFETY OF HOUSEHOLD AND SIMILAR ELECTRICAL
APPLIANCES**

This Standard deals with the safety of electrical appliances for household and similar purposes; the rated voltage of the appliances being not more than 250 V for single-phase appliances and 480 V for other appliances.

Recently the Standard has been modified and requirements are reportedly much stricter than those previously used, in order to avoid fire risks and provide further guarantees of safety in electrical appliances.

Such modifications involve, above all, components made of an insulating material that support electrical connections carrying a current >0.2A, including components at a distance of less than 3 mm from the connection.

The flowchart for the material and / or part evaluation according to IEC 60335-1 is schematically illustrated in figure.

**IEC60335-1
SICHERHEIT ELEKTRISCHER HAUSGERÄTE UND
ÄHNLICHE ANWENDUNGEN**

Die Norm schreibt die Anforderungen für die Sicherheit elektrischer Hausgeräte und ähnlichen Anwendungen vor, bei denen eine Nennspannung von 250V einphasig und 480V für andere Geräte nicht überschritten wird.

Vor Kurzem wurde diese Norm abgeändert und zur Vermeidung von Brandrisiken wesentlich verschärft um noch mehr Sicherheit beim Betrieb zu garantieren.

Die Änderungen betreffen die Isolationsmaterialien aller elektrischen Bauteile, bei denen die elektrische Verbindung einen Strom > 0,2A führt sowie die Bauteile, deren Abstand < 3mm von der Verbindung entfernt sind.

Das Flussdiagramm für das Isolationsmaterial und/ oder der Bauteileanforderung nach IEC60335-1 ist in der Abbildung schematisch dargestellt.

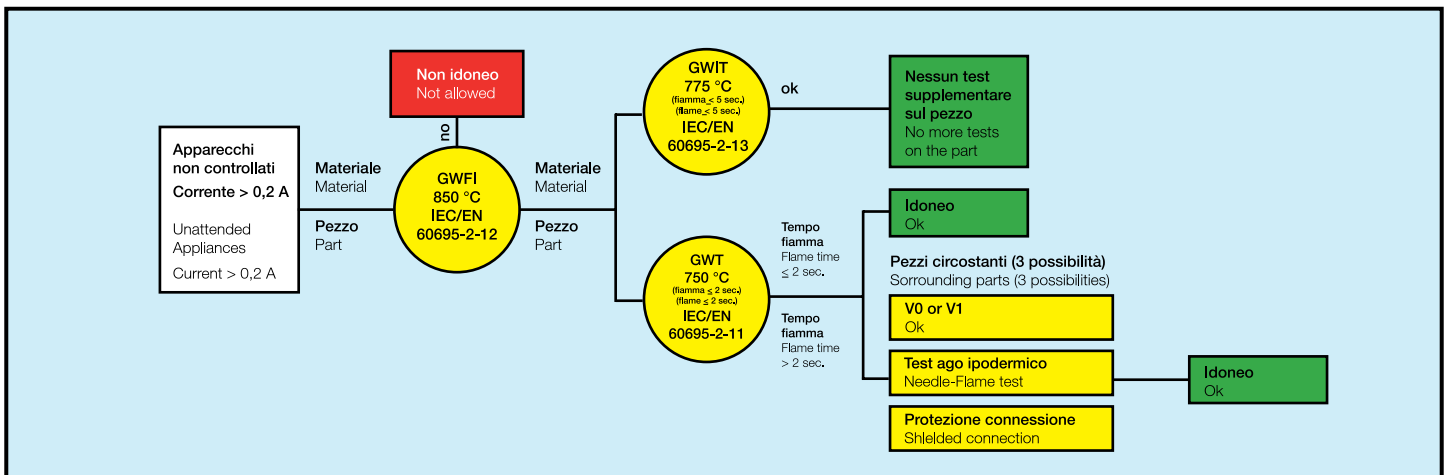

PARAGRAFO 30 – RESISTENZA AL CALORE ED AL FUOCO

30.1 - Resistenza al calore

I pezzi devono essere idonei al Test della Biglia (IEC 60695-10-2). La prova viene eseguita alla temperatura di $40\text{ °C} \pm 2$ al di sopra della temperatura massima rilevata sul pezzo durante il test previsto al punto 11, ma deve essere di almeno $75\text{ °C} \pm 2$ per parti esterne e $125\text{ °C} \pm 2$ per parti attive.

30.2 - Resistenza al fuoco**30.2.2 - Apparecchiature controllate**

La norma prevede che i pezzi siano sottoposti al test del Filo Incandescente (IEC 60695-2-11) da farsi a 750 °C per connessioni con corrente $> 0,5\text{A}$ e 650 °C per altre connessioni.

30.2.3 - Apparecchiature non controllate

30.2.3.1- I pezzi con passaggio di corrente $> 0,2\text{A}$ devono avere Glow-Wire Flammability Index (GWFI) $\geq 850\text{ °C}$ (secondo la IEC 60695-2-12).

30.2.3.2 - I pezzi che presentano connessioni elettriche, devono sempre essere sottoposti al Test del Filo Incandescente secondo IEC 60695-2-11, a meno che il materiale sia classificato secondo IEC 60695-2-13 con GWFI Glow-Wire Ignition Temperature (Temperatura di Accensione) di $\geq 775\text{ °C}$ per connessioni con correnti $> 0,2\text{A}$ e $\geq 675\text{ °C}$ per altre connessioni. Le prove devono essere fatte su spessore non superiore a quello del pezzo. Il tempo massimo di persistenza della fiamma ammesso durante la prova è di 5 secondi.

Se viene eseguita la prova del Filo Incandescente sui pezzi, secondo la IEC 60695-2-11, la temperatura deve essere di 750 °C per connessioni con corrente $> 0,2\text{A}$ e 650 °C per altre connessioni con correnti inferiori.

Nel caso in cui durante la prova si sviluppi una fiamma per un tempo > 2 secondi, deve essere eseguita la prova Fiamma con Ago Ipodermico (Needle Flame Test) per tutti i pezzi circostanti che si trovano sopra la connessione elettrica all'interno di un ipotetico cilindro verticale, avente diametro di 20 mm ed una altezza di 50 mm.

Quest'ultimo test non è necessario se tra le connessioni e gli altri pezzi esiste una protezione che supera il Test dell' Ago Ipodermico. Non è necessario fare il Test dell'Ago per pezzi realizzati con materiale classificato V-0 o V-1 (IEC 60695-11-10) per spessori non superiori a quelli del pezzo.

Come indicato nelle tabelle di selezione di ogni singolo capitolo STELVIO – KONTEK è in grado di fornire componenti in versione standard oppure in versione speciale conformi alla IEC 60335-1: per ordinare questi prodotti occorre semplicemente aggiungere al codice standard la dicitura GWT.

PARAGRAPH 30 - RESISTANCE TO HEAT AND FIRE

30.1 - Heat resistance

The parts must comply with the Ball Pressure Test (IEC 60695-10-2). The test is carried out at a temperature of $40\text{ °C} \pm 2\text{ °C}$ plus the maximum temperature rise determined during the test of clause 11, but it shall be at least $75\text{ °C} \pm 2\text{ °C}$ for external components and $125\text{ °C} \pm 2\text{ °C}$ for components supporting live parts.

30.2 - Fire resistance**30.2.2 - Attended Appliances**

According to the Standard, parts ought to be subjected to the Glow-Wire Test (IEC 60695-2-11), which is carried out at 750 °C for connections that carry a current $> 0.5\text{A}$ and 650 °C for other connections.

30.2.3 - Unattended Appliances

30.2.3.1: Parts that carry a current $> 0.2\text{A}$ shall have a Glow Wire Flammability Index (GWFI) $\geq 850\text{ °C}$ (IEC 60695-2-12).

30.2.3.2: parts supporting current/carrying connections shall always be subjected to the Glow-Wire Test according to IEC 60695-2-11. However, the GWT is not carried out on parts of material classified as having a Glow-Wire Ignition Temperature (GWIT-according to IEC 60695-2-13) of $\geq 775\text{ °C}$ for connections that carry a current $> 0.2\text{A}$, and $\geq 675\text{ °C}$ for other connections.

Test samples have to be no thicker than the relevant part.

The maximum flame-persistence time admitted during the test is of 5 seconds.

When the Glow-Wire Test of IEC 60695-2-11 is carried out on the parts, the temperatures are of 750 °C for connections which carry a current $> 0.2\text{ A}$ and 650 °C for lower connections. If during the test a flame that persists for longer than 2 seconds is produced, the Needle-Flame Test must be carried out for all parts above the connection within the envelope of a vertical cylinder having a diameter of 20 mm and a height of 50 mm. However, the latter test is not needed if between the connections and the other parts there is a «protection» that comply with the Needle-Flame Test.

The Needle-Flame Test is not carried out on parts of material classified as V-0 or V-1 (IEC 60695-11-10), provided that the test sample was no thicker than the relevant part.

STELVIO – KONTEK is able to provide both standard version components and special version components complying with IEC 60335-1, as shown in selection tables of each section.

In your purchase order, if you require the latter type of product, you can simply add "GWT" at the end of the standard code.

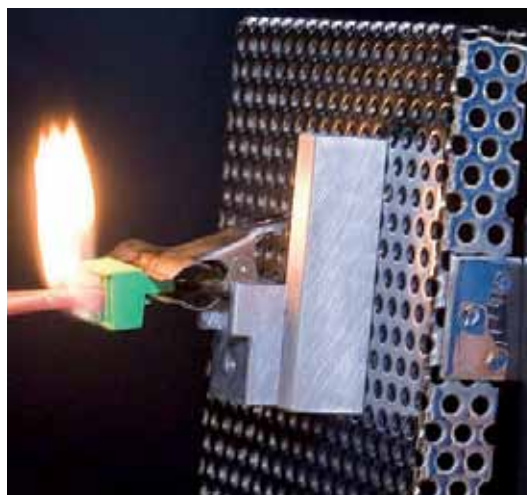

PARAGRAPHE 30 – RESISTANCE A LA CHALEUR ET AU FEU

30.1 - Résistance à la chaleur

Les pièces doivent répondre au test de la bille (IEC 60695-10-2). Le test est effectué à la température de $40^{\circ}\text{C} \pm 2$ en addition à la température maximum relevée sur la pièce durant le test prévu au point 11, mais doit être d'au moins $75^{\circ}\text{C} \pm 2$ pour les parties internes et $125^{\circ}\text{C} \pm 2$ pour les parties actives.

30.2 - Résistance au feu**30.2.2 - Appareillages contrôlés**

La norme prévoit que les pièces soient soumises au test du Fil incandescent (IEC 60695-2-11) exécuté à la température de 750°C pour les connexions ayant un courant de $> 0,5\text{A}$ et 650°C pour les autres connexions.

30.2.3 - Appareillages non contrôlés

30.2.3.1- Les pièces ayant un courant de passage de $> 0,2\text{A}$ doivent présenter un Glow-Wire Flammability Index (GWFI) $> = 850^{\circ}\text{C}$ (selon IEC 60695-2-12).

30.2.3.2 - Les pièces qui comportent des connexions électriques doivent toujours être soumises au Test du fil incandescent selon IEC 60695-2-11, à moins que le matériau ne soit classé selon IEC 60695-2-13 avec GWFI Glow-Wire Ignition Temperature [Température d'Allumage] de $> = 775^{\circ}\text{C}$ pour des connexions ayant des courants $> 0,2\text{A}$ et $> = 675^{\circ}\text{C}$ pour les autres connexions.

Les tests doivent toujours être effectués sur une épaisseur non supérieure à celle de la pièce. Le temps maximum de persistance de la flamme admis durant le test est de 5 secondes.

En cas d'épreuve du Fil incandescent sur les pièces selon IEC 60695-2-11, la température doit être de 750°C pour les connexions ayant un courant $> 0,2\text{A}$ et 650°C pour les autres connexions ayant des courants inférieurs.

Lors du test, le développement d'une flamme d'une durée > 2 secondes implique l'exécution du test de la Flamme avec Aiguille hypodermique (Needle Flame Test) pour toutes les pièces environnantes se trouvant au-dessus de la connexion électrique à l'intérieur d'un hypothétique cylindre vertical, ayant un diamètre de 20 mm et une hauteur de 50 mm.

Ce dernier test n'est pas nécessaire en cas de présence d'une protection entre les connexions et les autres pièces validées par la tenue au test de l'aiguille hypodermique.

Il n'est pas nécessaire d'effectuer le Test de l'Aiguille pour les pièces réalisées en matériau classé VO ou V1 (IEC 60695) pour des épaisseurs non supérieures à celles des pièces. Ainsi que le stipule le tableau de sélection STELVIO-KONTEK est en mesure de fournir des composants en version standard ou bien en version spéciale conforme à l'IEC 60335-1 : pour commander ces produits il suffit d'ajouter le suffixe GWT au code standard.

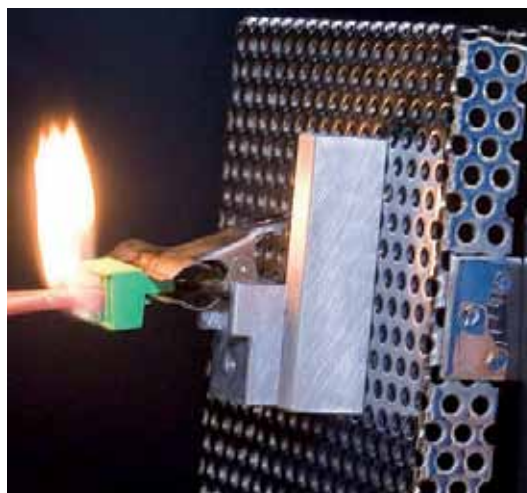

30 WÄRME - UND FEUERBESTÄNDIGKEIT

30.1 – Wärmebeständigkeit

Die Bauteile müssen der Kugeldruckprüfung (IEC 60695-10-2) entsprechen. Die Prüfung wird bei einer Temperatur von $40^{\circ}\text{C} \pm 2^{\circ}\text{C}$ plus dem maximalen Temperaturanstieg der während der Prüfung nach Abschnitt 11 ermittelt wird, durchgeführt, mindestens jedoch bei $75^{\circ}\text{C} \pm 2^{\circ}\text{C}$ für außenliegende Bauteile und $125^{\circ}\text{C} \pm 2^{\circ}\text{C}$ für Teile, die stromführende Bauteile halten.

30.2 – Feuerbeständigkeit**30.2.2. Geräte, die beaufsichtigt betrieben werden**

Die Bauteile müssen der Glühdrahtprüfung (IEC 60695-2-11) entsprechen. Die Prüfung wird bei einer Temperatur von 750°C für Verbindungen durchgeführt, die einen Strom $> 0,5\text{A}$ während des Normalbetriebs führen bzw. mit 650°C für andere Verbindungen.

30.2.3. – Geräte, die unbeaufsichtigt betrieben werden

30.2.3.1 – Bauteile, die einen Strom von mehr als $0,2\text{A}$ während des Normalbetriebs führen, müssen einen Glühdrahtentflammbarkeitsindex (glow-wire-flammability index, GWFI) von mindestens 850°C nach IEC 60695-2-12 haben.

30.2.3.2 – Bauteile, die Strom führende Verbindungen tragen, müssen der Glühdrahtprüfung nach IEC 60695-2-11 entsprechen. Die Glühdrahtprüfung wird jedoch nicht an Bauteilen durchgeführt, deren Werkstoff eine Glühdrahtendzündungstemperatur nach IEC 60695-2-13 (glow-wire-ignition-temperature GWIT) von $> 775^{\circ}\text{C}$ einhalten sowie bei Verbindungen, die einen Strom von mehr als $0,2\text{A}$ während des Normalbetriebes führen und $> 675^{\circ}\text{C}$ bei anderen Verbindungen. Die Prüfmuster dürfen nicht dicker als die Originalteile sein. Die max. Flammdauer während der Prüfung beträgt 5s. Wird die Glühdrahtprüfung nach IEC 60695-2-11 durchgeführt, gelten die Temperaturen von 750°C für Verbindungen, die einen Strom von mehr als $0,2\text{A}$ während des Normalbetriebs führen und von 650°C für andere Verbindungen mit kleinerem Strom. Bei Bauteilen, bei denen während der Prüfung eine Flammdauer von mehr als 2s auftritt, muss die Nadelflammprüfung für alle darüber liegenden Bauteile innerhalb eines Zylinders mit einem Durchmesser von 20 mm und einer Höhe von 50 mm durchgeführt werden. Dieser Test ist jedoch nicht erforderlich, wenn sich zwischen beiden Bauteilen eine Flammbarriere befindet, die der Nadelflammprüfung entspricht. Die Nadelflammprüfung wird nicht an Bauteilen durchgeführt, die aus einem Werkstoff bestehen, der als V-0 oder V-1 nach IEC 60695-11-10 eingeordnet ist, vorausgesetzt, das Prüfmuster war nicht dicker als das entsprechende Originalteil. Wie in den Tabellen der einzelnen Abschnitte aufgeführt, kann S STELVIO-KONTEK die Bauteile sowohl in Standardausführung als auch in Sonderausführung gemäß IEC 60335-1 liefern. Bei Bestellungen der Sonderausführung ist dem normalen Bestellcode nur GWT hinzuzufügen.

D

THR - THROUGH HOLE REFLOW

Componenti quali morsetti e connettori, essendo sottoposti a sforzi meccanici durante l'utilizzo, richiedono una buona tenuta meccanica alla scheda elettronica.

Per garantire sia l'efficienza produttiva tipica della tecnologia SMT (Surface Mount Technology) che la resistenza meccanica data dalla tecnologia THT (Through Hole Technology), i due metodi possono essere integrati in un unico processo denominato THR (Through Hole Reflow).

Questo processo viene anche denominato PIP (Pin In Paste) e a differenza dei componenti SMT tradizionali, i pin dei connettori, morsetti e portafusibili vengono inseriti nei fori metallizzati del circuito stampato preventivamente riempiti con la pasta saldante e successivamente saldati con tecnologia Reflow come descritto nello schema seguente.

Mechanically stressed components such as terminal blocks and connectors require a good retention to the PC board. In order to obtain the same efficiency in production of SMT process (Surface Mount Technology) and mechanical resistance typical of THT process (Through Hole Technology), these two technologies can be integrated in one process named THR (Through Hole Reflow).

This process or method is also known as a PIP (Pin In Paste) and differently from SMT traditional components, the pins of connectors, terminal blocks and fuse-holders are inserted into PCB plated through holes previously filled with soldering paste and then soldered with Reflow technology as described on the following pictures.

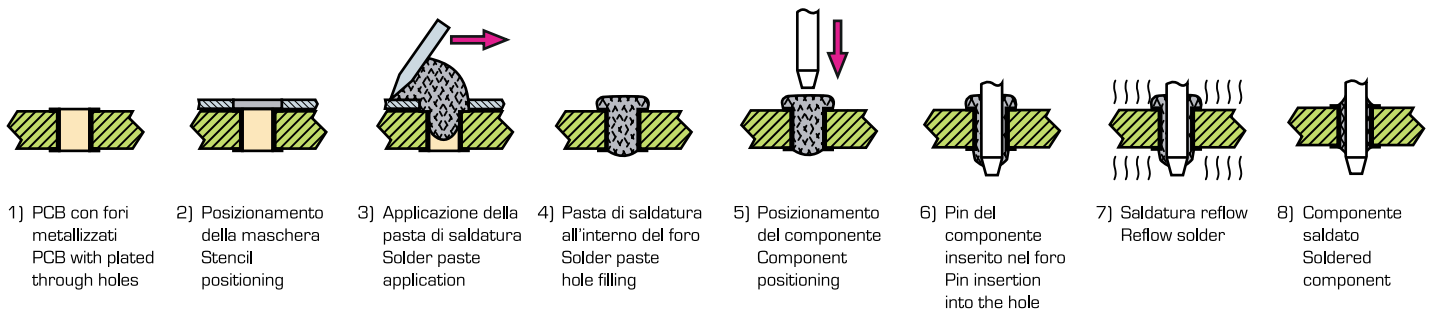

CARATTERISTICHE DEL CS

- 1) Fori metallizzati;
- 2) Diametro del foro : dipende dalle dimensioni del pin e dalla precisione del posizionamento del componente;
- 3) Diametro piazzola : dipende dalla dimensione del terminale, dalla quantità di pasta saldante e dalla maschera;
- 4) Il volume della pasta saldante può essere calcolato come segue:

PCB CHARACTERISTICS

- 1) Plated through holes;
- 2) Holes diameter: depends on pin dimension and on the accuracy of component deployment;
- 3) Soldering pad: depend on the pin dimension, paste quantity and stencil layout;
- 4) Volume of soldering paste can be calculated as follow:

$$V_h = \left[\frac{\pi d_h^2 \cdot S}{4} \right]$$

$$V_n = V_h - V_p$$

$$\text{Volume pasta} / \text{Paste volume} = V_n \cdot K$$

V_h = Volume foro / Hole volume

V_n = Volume netto / Net volume

V_p = Volume del pin / Soldering pin volume

S = Spessore del CS / PCB thickness

d_h = Diametro foro su CS / PCB hole diameter

K = Fattore di evaporazione

[uguale a 2 considerando un fattore di evaporazione della pasta saldante pari al 50%]

Evaporation factor

[equal to 2 with paste estimated bleeding of 50%]

D

THR - THROUGH HOLE REFLOW

Valori indicativi sono specificati nei disegni e tabelle seguenti / Approximate value are shown on following drawing and table

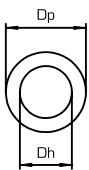
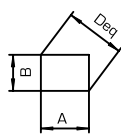
FORATURA PCB PCB HOLES	DIMENSIONI PIN PIN DIMENSIONS	DIMENSIONI DIMENSIONS	Componente Product	Dimensioni PIN PIN dimensions	Diametro equivalente Deq Equivalent diameter Deq	Diametro foro Dh Hole diameter Dh	Diametro piazzola Pad diameter	Foro lastra Stencil hole
		$Deq = \sqrt{A^2 + B^2}$ $Dh = Deq + 0,25 \text{ mm}$ $Dp = Dh + 0,6 \text{ mm}$	CPP / CPA	0,90 x 0,50	1,00	1,25	1,85	1,95
			CII / CIA	1,00 x 0,50	1,10	1,35	1,95	2,05
			CLL / CLA	0,90 x 0,90	1,30	1,55	2,15	2,25
			COB	1,00 x 0,70	1,20	1,45	2,05	2,15
			MRT12	0,70 x 1,00	1,20	1,45	2,05	2,15
			CBL	0,70 x 1,00	1,20	1,45	2,05	2,15
			MRT9	0,80 x 0,80	1,10	1,35	1,95	2,05
			CUM	0,70 x 1,00	1,20	1,45	2,05	2,15
			CPM	1,00 x 1,00	1,40	1,65	2,25	2,35

Dh = Diametro foro / Inner hole diameter
Dp = Diametro piazzola / Pad diameter

PROFILI DI SALDATURA

I profili di saldatura consigliati per i componenti THR sono specificati dalle norme DIN EN 61760-1.

TEMPERATURE REQUIREMENTS

Recommended temperature profiles are specified in DIN EN 61760-1.

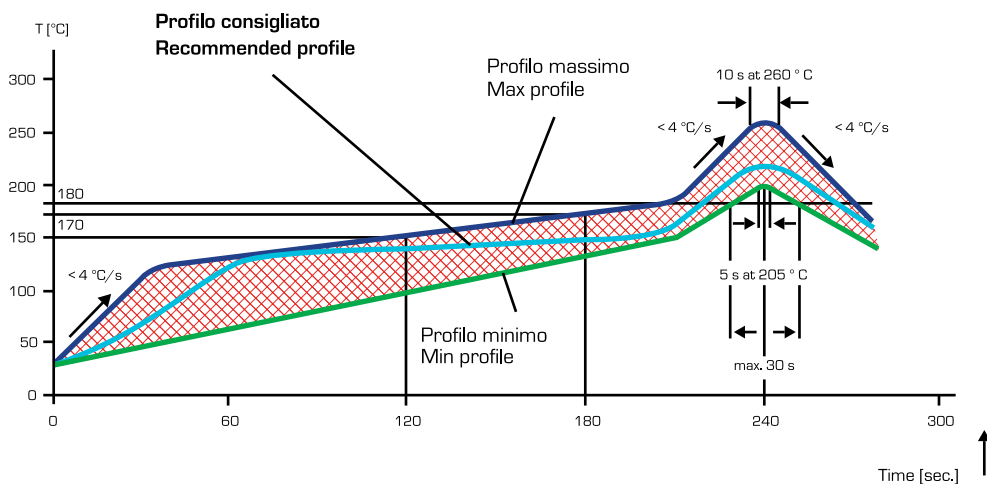

IMBALLO

I componenti THR sono compatibili con sistemi di montaggio automatico (Pick and Place) grazie a differenti soluzioni di imballo quali il Tube ed il Tape-and-Reel.
Per ogni ulteriore informazione contattateci

PACKAGING

THR components are also compatible with automated mounting systems (Pick and Place) thanks to packaging solutions such as Tube or Tape-and-Reel.
For any requirements on THR components contact us.

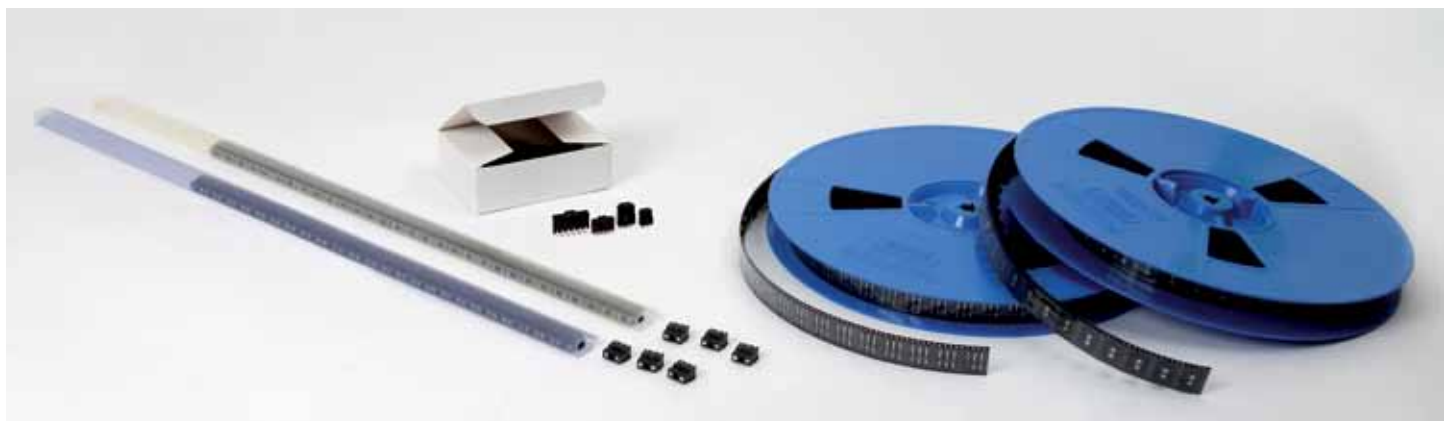

THR - THROUGH HOLE REFLOW

Les composants soumis à d'importantes forces mécaniques comme les borniers, portes-fusible ou connecteurs, doivent être solidement soudés à la carte électronique afin que leur fonction d'interconnexion soit garantie pendant toute leur durée de vie. Afin d'associer le gain de productivité de la technologie CMS ou SMT (Surface Mount Technology) et la performance mécanique éprouvée de la technologie "à piquer" ou THT (Through Hole Technology), le process unique THR a été développé (ou technique de refusion à trous traversant). Celui-ci, aussi appelé PIP (Pin In Paste), à la différence du process CMS traditionnel, requiert l'insertion des Pins des composants (borniers, connecteurs, portes-fusible) dans les trous métallisés de la carte préalablement garnis de pâte à braser. Une soudure de type Refusion ou Reflow est ensuite appliquée.

Bauteils wie Anschlussklemmen und Steckverbinder, die hohen, mechanischen Beanspruchungen ausgesetzt sind, benötigen einen festen, mechanischen Halt auf der Platine. Um sowohl die gleiche Produktivität, die typisch für die SMT-Verarbeitung (Surface Mount Technology) ist als auch die mechanische Festigkeit wie bei der THT-Verarbeitung (Through Hole Technology) zu erreichen, werden beide Technologien in einem einzigen Verfahren, der THR-Verarbeitung (Through Hole Reflow) zusammengefasst. Dieses Verfahren ist auch als PIP (Pin In Paste) bekannt und hierbei werden anders als bei herkömmlichen SMT-Bauteilen die Anschlussstifte der Steckverbinder, Leiterplattenklemmen und Sicherungshalter in durchkontaktierte Bohrungen der Platine, die bereits mit Lötpaste befüllt sind, eingesetzt und in Reflow-Technologie gelötet, so wie in dem nachfolgenden Schema beschrieben.

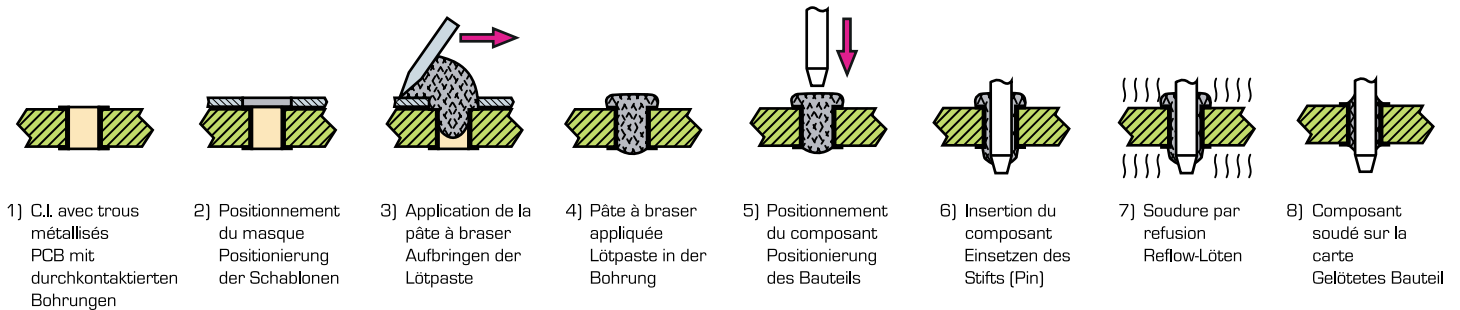

CARACTÉRISTIQUES DU CIRCUIT IMPRIMÉ

- 1) Trous métallisés;
- 2) Le diamètre du trou est dépendant des dimensions des pins du composant ainsi que la de la précision avec laquelle celui-ci est positionné;
- 3) Le diamètre du pad métallique est dépendant des dimensions des pins et du masque ainsi que de la quantité de pâte à braser;
- 4) Le volume de la pâte à braser à utiliser peut être calculé comme selon:

EIGENSCHAFTEN DER PLATINE

- 1) Durchkontaktierte Bohrungen;
- 2) Bohrdurchmesser sind abhängig von den Stiftabmessungen und der Positioniergenauigkeit der Bauteile;
- 3) Lötungenabmessungen sind abhängig von den Stiftabmessungen, der Menge der Lötpaste und der Schablonenform;
- 4) Die Menge der Lötpaste kann gemäß nachfolgender Formel ermittelt werden:

$$V_h = \left[\frac{\pi d_h^2 \cdot S}{4} \right]$$

$$V_n = V_h - V_p$$

$$\text{Volume Pâte / Lötpastenvolumen} = V_n \cdot K$$

V_h = Volume du trou / Lochvolumen

V_n = Volume Net / Netto Volumen

V_p = Volume du Pin / Stiftvolumen

S = Epaisseur du C.I. / Platinendicke

d_h = Diamètre du perçage sur le C.I. / Querschnitt der Bohrung auf der Platine

K = Facteur d'évaporation

(égal à 2 en considérant une évaporation de la pâte à braser à 50% de son volume initial)

Verflüchtigungsfaktor

(gleich 2, wenn man einen Verflüchtigungsfaktor der Lötpaste gleich 50 % berücksichtigt)

D

THR - THROUGH HOLE REFLOW

Les valeurs indicatives sont données dans le schéma et le tableau suivants / Richtwerte sind in nachfolgenden Zeichnungen und Tabellen aufgeführt

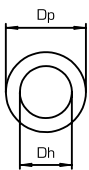
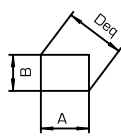
FORATURA PCB PCB HOLES	DIMENSIONI PIN PIN DIMENSIONS	DIMENSIONI DIMENSIONS	Componente Product	Dimensioni PIN PIN dimensions	Diametro equivalente Deq Equivalent diameter Deq	Diametro foro Dh Hole diameter Dh	Diametro piazzola Pad diameter	Foro lastra Stencil hole
		$Deq = \sqrt{A^2 + B^2}$ $Dh = Deq + 0,25 \text{ mm}$ $Dp = Dh + 0,6 \text{ mm}$	CPP / CPA	0,90 x 0,50	1,00	1,25	1,85	1,95
			CII / CIA	1,00 x 0,50	1,10	1,35	1,95	2,05
			CLL / CLA	0,90 x 0,90	1,30	1,55	2,15	2,25
			COB	1,00 x 0,70	1,20	1,45	2,05	2,15
			MRT12	0,70 x 1,00	1,20	1,45	2,05	2,15
			CBL	0,70 x 1,00	1,20	1,45	2,05	2,15
			MRT9	0,80 x 0,80	1,10	1,35	1,95	2,05
			CUM	0,70 x 1,00	1,20	1,45	2,05	2,15
			CPM	1,00 x 1,00	1,40	1,65	2,25	2,35

Dh = Diametro foro / Inner hole diameter
Dp = Diametro piazzola / Pad diameter

PROFILS DE SOUDURE

Les profils de soudure pour les composants THR sont définis par la norme DIN EN 61760-1

LÖTPROFILE

Die empfohlenen Löttemperaturen für THR-Bauteile sind in der DIN EN 61760-1 aufgeführt

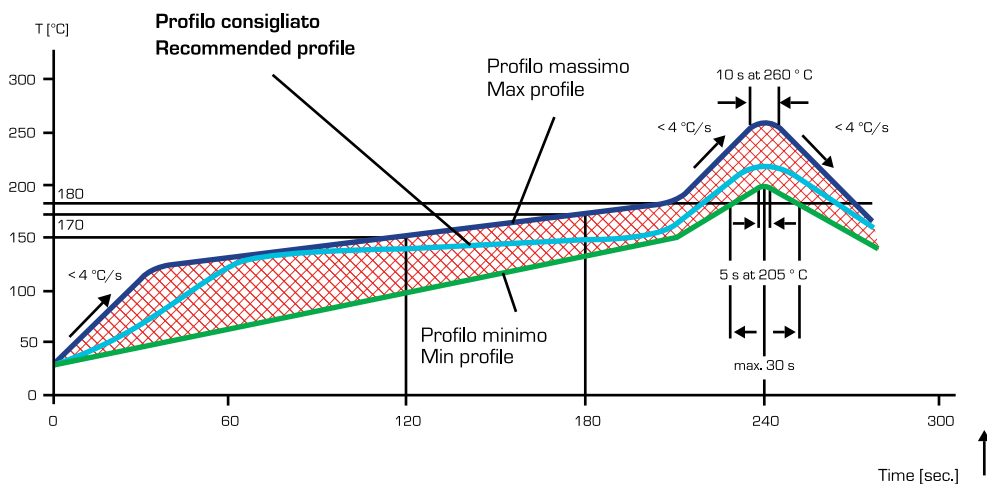

EMBALLAGE

Les composants THR Stelvio_Kontek sont compatibles avec les systèmes de placement automatique des composants (Pick & Place) grâce à diverses solutions d'emballage comme le Tube ou la Bobine (Tape & Reel). Pour toute demande complémentaire, n'hésitez pas à nous solliciter.

VERPACKUNG

THR-Bauteile sind dank der Stangen- bzw. Rollenverpackung vollautomatisch bestückbar.
Für zusätzliche Informationen kontaktieren Sie uns bitte.

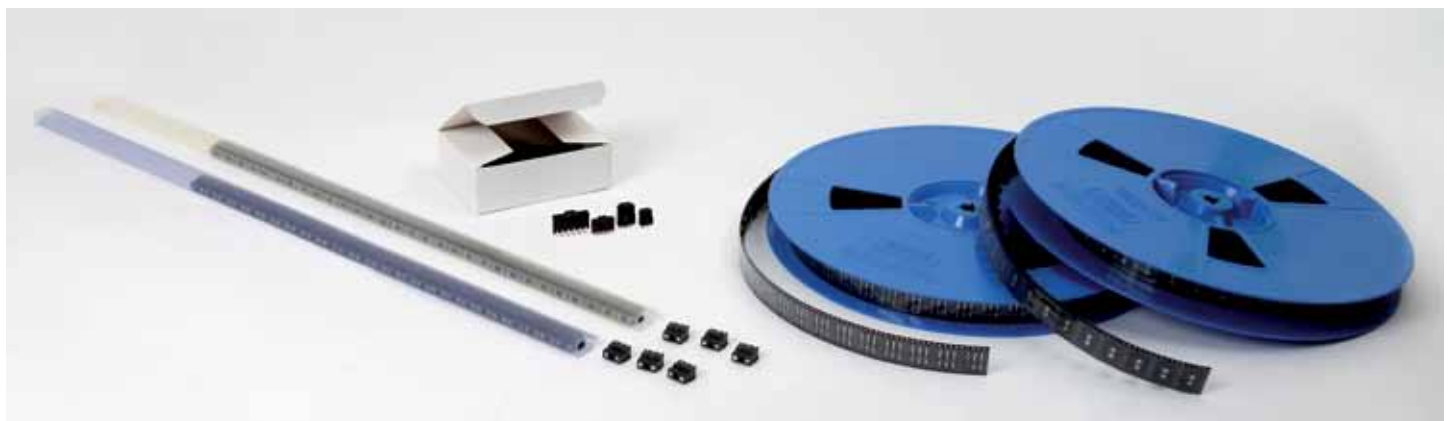



**INTERNATIONAL APPROVALS
ON SPECIFIC PRODUCTS:**



D

Dati tecnici
Technical data
Données techniques
Technische Daten

NOTA IMPORTANTE

A seguito dei continui sviluppi sui prodotti e processi produttivi, l'azienda si riserva il diritto di modificare i dati del presente catalogo senza preavviso.

Saremo lieti di discutere richieste specifiche.

IMPORTANT NOTICE

Due to continuous development of our products, together with altering manufacturing methods, the descriptions and data provided are for information only and subject to changes without notice.

We will be pleased to discuss detailed requirements.

ATTENTION

Nos produits sont adaptés au fur et à mesure des évolutions techniques. Toutes modifications techniques réservées. Par conséquent des différences peuvent exister avec les données techniques indiquées.

Nous sommes à votre entière disposition pour plus de renseignements.

WICHTIGER HINWEIS

Unsere Produkte werden stets den neuesten Erkenntnissen der Technik angepasst. Konstruktionsänderungen die dem technischen Fortschritt dienen, behalten wir uns vor. Daher sind Abweichungen von den aufgeführten technischen Daten möglich.

Zu weiteren Auskünften stehen wir Ihnen gerne zur Verfügung.

D

Riferimenti	References	Références	Referenzen
Sezione	Section	Section	Kapitel
Passo	Pitch	Pas	Rastermaß
Dati generali	General data	Caractéristiques générales	Allgemeine Daten
Gruppo isolante	Insulating group	Groupe isolant	Isolierstoff-Gruppe
Tensione impulsiva di dimensionamento	Impulse withstand voltage	Tension impulsive de dimensionnement	Stoßspannungsfestigkeit
Categoria di sovratensione / Grado di inquinamento	Overvoltage category / Pollution degree	Catégorie de surtension / Degré de pollution	Überspannungskategorie / Verschmutzungsgrad
Tensione di dimensionamento	Withstand voltage	Tension de dimensionnement	Spannungsfestigkeit
Corrente max/ Sezione nominale (Rigido/Flessibile)	Max current / Nominal section (Rigid/Flexible)	Intensité max / Section nominale (Rigide/Flexible)	max. Strom / Nennquerschnitt (Starr/Flexibel)
Corrente max/ Sezione nominale (Rigido/Flessibile)	Max current / Nominal section (Rigid/Flexible)	Intensité max / Section nominale (Rigide/Flexible)	max. Strom / Nennquerschnitt (Starr/Flexibel)
Indice di protezione	Protection index	Indice de protection	Schutzgrad
Rigidità dielettrica (EN 60998)	Dielectric strength (EN 60998)	Rigidité diélectrique (EN 60998)	Durchschlagsfestigkeit (EN 60998)
Varie	Various	Divers	Verschiedenes
Calibro d'accessibilità cavi (IEC 60947-1)	Gauge (IEC 60947-1)	Calibre (IEC 60947-1)	Lehrdom (IEC 60947-1)
Dimensione pin / Foro di montaggio	Pin dimension / Hole diameter	Dimension pin / Diamètre de perçage	Lötstiftabmessungen / Bohrloch
Vite imperdibile flange	Captive screw for flanges	Vis imperdable sur oreilles de fixation	Unverlierbare Schraube für Flanschbefestigung
Coppia di torsione	Torque	Couple de serrage	Drehmoment
Materiale	Material	Matériau	Material
Plastico isolante / Autoestinguenza	Insulating material / Flammability	Plastique isolant / Autoextinguibilité	Isolierstoff / Entflammbarkeit
Morsetto o Molla / Trattamento galvanico	Clamp or spring / Plating	Bloc de jonction ou ressort / Traitement galvanique	Klemmkörper oder Feder/Platierung
Terminale per C.S. / Trattamento galvanico	Contact to P.C.B. / Plating	Picot pour CI / Traitement galvanique	Lötstift / Platierung
Terminale / Trattamento galvanico	Contact / Plating	Picot / Traitement galvanique	Kontakt / Platierung
Linguetta di protezione	Wire protection	Languette de protection	Drahtschutz
Vite / Trattamento galvanico	Screw / Plating	Vis / Traitement galvanique	Schraube / Platierung

Riferimenti	References	Références	Referenzen
Sezione	Section	Section	Kapitel
Passo	Pitch	Pas	Rastermaß
Dati generali	General data	Caractéristiques générales	Allgemeine Daten
Gruppo isolante	Insulating group	Groupe isolant	Isolierstoff-Gruppe
Tensione impulsiva di dimensionamento	Impulse withstand voltage	Tension impulsive de dimensionnement	Stoßspannungsfestigkeit
Categoria di sovratensione / Grado di inquinamento	Overvoltage category / Pollution degree	Catégorie de surtension / Degré de pollution	Überspannungskategorie / Verschmutzungsgrad
Tensione di dimensionamento	Withstand voltage	Tension de dimensionnement	Spannungsfestigkeit
Corrente max/ Sezione nominale (Rigido/Flessibile)	Max current / Nominal section (Rigid/Flexible)	Intensité max / Section nominale (Rigide/Flexible)	max. Strom / Nennquerschnitt (Starr/Flexibel)
Corrente max/ Sezione nominale (Rigido/Flessibile)	Max current / Nominal section (Rigid/Flexible)	Intensité max / Section nominale (Rigide/Flexible)	max. Strom / Nennquerschnitt (Starr/Flexibel)
Indice di protezione	Protection index	Indice de protection	Schutzgrad
Rigidità dielettrica (EN 60998)	Dielectric strength (EN 60998)	Rigidité diélectrique (EN 60998)	Durchschlagsfestigkeit (EN 60998)
Varie	Various	Divers	Verschiedenes
Calibro d'accessibilità cavi (IEC 60947-1)	Gauge (IEC 60947-1)	Calibre (IEC 60947-1)	Lehrdom (IEC 60947-1)
Dimensione pin / Foro di montaggio	Pin dimension / Hole diameter	Dimension pin / Diamètre de perçage	Lötstiftabmessungen / Bohrloch
Vite imperdibile flange	Captive screw for flanges	Vis imperdable sur oreilles de fixation	Unverlierbare Schraube für Flanschbefestigung
Coppia di torsione	Torque	Couple de serrage	Drehmoment
Materiale	Material	Matériau	Material
Plastico isolante / Autoestinguenza	Insulating material / Flammability	Plastique isolant / Autoextinguibilité	Isolierstoff / Entflammbarkeit
Morsetto o Molla / Trattamento galvanico	Clamp or spring / Plating	Bloc de jonction ou ressort / Traitement galvanique	Klemmkörper oder Feder/Platierung
Terminale per C.S. / Trattamento galvanico	Contact to P.C.B. / Plating	Picot pour CI / Traitement galvanique	Lötstift / Platierung
Terminale / Trattamento galvanico	Contact / Plating	Picot / Traitement galvanique	Kontakt / Platierung
Linguetta di protezione	Wire protection	Languette de protection	Drahtschutz
Vite / Trattamento galvanico	Screw / Plating	Vis / Traitement galvanique	Schraube / Platierung

Morsetti per C.S. a carrello
 Blocs de jonction C.I. étrier remontant

Terminal blocks for P.C.B. rising clamp
 Printklemmen Liftprinzip



	CPP		CPP..SQ		CPP		CPP..SQ		CPA		CPA..SQ	
mm	3,5	3,81	3,5	3,81	7	7,62*	7	7,62*	3,5	3,81	3,5	3,81

	I			I			I			I			I			I		
KV	2,5	2,5	2,5	2,5	2,5	2,5	4	4	4	4	4	4	2,5	2,5	2,5	2,5	2,5	2,5
—/—	III/3	III/2	II/2	III/3	III/2	II/2	III/3	III/2	II/2	III/3	III/2	II/2	III/3	III/2	II/2	III/3	III/2	II/2
V	160	250	400	160	250	400	400/500*	500/630*	630/630*	400/500*	500/630*	630/630*	160	250	400	160	250	400
A/mm ²	10/1,0; 10/1,0			10/1,0; 10/1,0			10/1,0; 10/1,0			10/1,0; 10/1,0			10/1,0; 10/1,0			10/1,0; 10/1,0		
A/AWG	10/16; 10/16			10/16; 10/16			10/16; 10/16			10/16; 10/16			10/16; 10/16			10/16; 10/16		
—	IP 00			IP 00			IP 00			IP 00			IP 00			IP 00		
KV	1,25			1,25			2,5			2,5			1,25			1,25		

mm	—/1,2	—/1,2	—/1,2	—/1,2	—/1,2	—/1,2
mm	0,9X0,5/1,1	0,9X0,5/1,1	0,9X0,5/1,1	0,9X0,5/1,1	0,9X0,5/1,1	0,9X0,5/1,1
Nm						

—	PA - UL94 V0	PA - UL94 V0	PA - UL94 V0	PA - UL94 V0	PA - UL94 V0	PA - UL94 V0
—	CuZn 39 Pb2 / Ni + Sn	CuZn 39 Pb2 / Ni + Sn	CuZn 39 Pb2 / Ni + Sn	CuZn 39 Pb2 / Ni + Sn	CuZn 39 Pb2 / Ni + Sn	CuZn 39 Pb2 / Ni + Sn
—	CuZn 37 / Ni + Sn	CuZn 37 / Ni + Sn	CuZn 37 / Ni + Sn	CuZn 37 / Ni + Sn	CuZn 37 / Ni + Sn	CuZn 37 / Ni + Sn
—	—	—	—	—	—	—
—	—	—	—	—	—	—
—	C18 / Zn	C18 / Zn	C18 / Zn	C18 / Zn	C18 / Zn	C18 / Zn



	CPA		CPA..SQ		COB		COB		CII		CII..SQ	
mm	7	7,62*	7	7,62*	5	5,08	10	10,16	5	5,08	5	5,08

	I			I			I			I			I			I		
KV	4	4	4	4	4	4	2,5	2,5	2,5	6	6	6	4	4	4	4	4	4
—/—	III/3	III/2	II/2	III/3	III/2	II/2	III/3	III/2	II/2	III/3	III/2	II/2	III/3	III/2	II/2	III/3	III/2	II/2
V	400/500* 500/630* 630/630*			400/500* 500/630* 630/630*			160	250	400	500	630	1000	250	500	630	250	500	630
A/mm ²	10/1,0; 10/1,0			10/1,0; 10/1,0			24/2,5; 24/2,5			24/2,5; 24/2,5			14/1,5; 14/1,5			14/1,5; 14/1,5		
A/AWG	10/16; 10/16			10/16; 10/16			16/12; 16/12			16/12; 16/12			14/14; 14/14			14/14; 14/14		
—	IP 00			IP 00			IP 00			IP 00			IP 00			IP 00		
KV	2,5			2,5			1,25			3			2			2		

mm	—/1,2	—/1,2	2,8X2,0/2,4	2,8X2,0/2,4	2,4X1,5/1,9	2,4X1,5/1,9
mm	0,9X0,5/1,1	0,9X0,5/1,1	1X0,7/1,3	1X0,7/1,3	1X0,5/1,3	1X0,5/1,3
Nm						

—	PA - UL94 V0	PA - UL94 V0	PA - UL94 V0	PA - UL94 V0	PA - UL94 V0	PA - UL94 V0
—	CuZn 39 Pb2 / Ni + Sn	CuZn 39 Pb2 / Ni + Sn	C60 / Zn	C60 / Zn	CuZn 39 Pb2 / Ni + Sn	CuZn 39 Pb2 / Ni + Sn
—	CuZn 37 / Ni + Sn	CuZn 37 / Ni + Sn	CuZn 37 / Ni + Sn	CuZn 37 / Ni + Sn	CuZn 37 / Ni + Sn	CuZn 37 / Ni + Sn
—	—	—	—	—	—	—
—	—	—	—	—	—	—
—	C18 / Zn	C18 / Zn	C18 / Zn	C18 / Zn	C18 / Zn	C18 / Zn

Morsetti per C.S. a carrello
 Blocs de jonction C.I. étrier remontant

Terminal blocks for P.C.B. rising clamp
 Printklemmen Liftprinzip



	CII		CII..SQ		CIA		CIA..SQ		CIA		CIA..SQ	
mm	A1 10 10,16		A1 10 10,16		A1 5 5,08		A1 5 5,08		A1 10 10,16		A1 10 10,16	

	CII			CII..SQ			CIA			CIA..SQ			CIA			CIA..SQ		
KV	I 6 6 6			I 6 6 6			I 4 4 4			I 4 4 4			I 6 6 6			I 6 6 6		
—/—	III/3 III/2 II/2			III/3 III/2 II/2			III/3 III/2 II/2			III/3 III/2 II/2			III/3 III/2 II/2			III/3 III/2 II/2		
V	630 630 1000			630 630 1000			250 500 630			250 500 630			630 630 1000			630 630 1000		
A/mm²	14/1,5; 14/1,5			14/1,5; 14/1,5			14/1,5; 14/1,5			14/1,5; 14/1,5			14/1,5; 14/1,5			14/1,5; 14/1,5		
A/AWG	14/14; 14/14			14/14; 14/14			14/14; 14/14			14/14; 14/14			14/14; 14/14			14/14; 14/14		
—	IP 00			IP 00			IP 00			IP 00			IP 00			IP 00		
KV	3			3			2			2			3			3		

mm	2,4x1,5/1,9		2,4x1,5/1,9		2,4x1,5/1,9		2,4x1,5/1,9		2,4x1,5/1,9		2,4x1,5/1,9	
mm	1x0,5/1,3		1x0,5/1,3		1x0,5/1,3		1x0,5/1,3		1x0,5/1,3		1x0,5/1,3	
Nm												

—	PA - UL94 V0		PA - UL94 V0		PA - UL94 V0		PA - UL94 V0		PA - UL94 V0		PA - UL94 V0	
—	CuZn 39 Pb2 / Ni + Sn		CuZn 39 Pb2 / Ni + Sn		CuZn 39 Pb2 / Ni + Sn		CuZn 39 Pb2 / Ni + Sn		CuZn 39 Pb2 / Ni + Sn		CuZn 39 Pb2 / Ni + Sn	
—	CuZn 37 / Ni + Sn		CuZn 37 / Ni + Sn		CuZn 37 / Ni + Sn		CuZn 37 / Ni + Sn		CuZn 37 / Ni + Sn		CuZn 37 / Ni + Sn	
—	—		—		—		—		—		—	
—	—		—		—		—		—		—	
—	C18 / Zn		C18 / Zn		C18 / Zn		C18 / Zn		C18 / Zn		C18 / Zn	



	CLL		CLL..SQ		CLL		CLL..SQ		CLL		CLL..SQ	
mm	A1 5 5,08		A1 5 5,08		A1 7,5 7,62		A1 7,5 7,62		A1 10 10,16		A1 10 10,16	

	CLL			CLL..SQ			CLL			CLL..SQ			CLL			CLL..SQ		
KV	I 4 4 4			I 4 4 4			I 6 6 6			I 6 6 6			I 6 6 6			I 6 6 6		
—/—	III/3 III/2 II/2			III/3 III/2 II/2			III/3 III/2 II/2			III/3 III/2 II/2			III/3 III/2 II/2			III/3 III/2 II/2		
V	250 500 630			250 500 630			500 630 1000			500 630 1000			630 630 1000			630 630 1000		
A/mm²	24/2,5; 24/2,5			24/2,5; 24/2,5			24/2,5; 24/2,5			24/2,5; 24/2,5			24/2,5; 24/2,5			24/2,5; 24/2,5		
A/AWG	14/12; 14/12			14/12; 14/12			14/12; 14/12			14/12; 14/12			14/12; 14/12			14/12; 14/12		
—	IP 00			IP 00			IP 00			IP 00			IP 00			IP 00		
KV	2			2			3			3			3			3		

mm	2,4x1,5/2,4		2,4x1,5/2,4		2,4x1,5/2,4		2,4x1,5/2,4		2,4x1,5/2,4		2,4x1,5/2,4	
mm	0,9x0,9/1,5		0,9x0,9/1,5		0,9x0,9/1,5		0,9x0,9/1,5		0,9x0,9/1,5		0,9x0,9/1,5	
Nm												

—	PA - UL94 V0		PA - UL94 V0		PA - UL94 V0		PA - UL94 V0		PA - UL94 V0		PA - UL94 V0	
—	CuZn 39 Pb2 / Ni + Sn		CuZn 39 Pb2 / Ni + Sn		CuZn 39 Pb2 / Ni + Sn		CuZn 39 Pb2 / Ni + Sn		CuZn 39 Pb2 / Ni + Sn		CuZn 39 Pb2 / Ni + Sn	
—	CuZn 37 / Ni + Sn		CuZn 37 / Ni + Sn		CuZn 37 / Ni + Sn		CuZn 37 / Ni + Sn		CuZn 37 / Ni + Sn		CuZn 37 / Ni + Sn	
—	—		—		—		—		—		—	
—	—		—		—		—		—		—	
—	C18 / Zn		C18 / Zn		C18 / Zn		C18 / Zn		C18 / Zn		C18 / Zn	

D/
A1

Morsetti per C.S. a carrello
 Blocs de jonction C.I. étrier remontant

Terminal blocks for P.C.B. rising clamp
 Printklemmen Liftprinzip



	CLA		CLA..SQ		CLA		CLA..SQ		CLA		CLA..SQ	
mm	5	5,08	5	5,08	7,5	7,5	7,5	7,5	10	10,16	10	10,16

	CLA			CLA..SQ			CLA			CLA..SQ			CLA			CLA..SQ		
KV	4	4	4	4	4	4	6	6	6	6	6	6	6	6	6	6	6	6
—/—	III/3	II/2	II/2	III/3	II/2	II/2	III/3	II/2	II/2	III/3	II/2	II/2	III/3	II/2	II/2	III/3	II/2	II/2
V	250	500	630	250	500	630	500	630	1000	500	630	1000	630	630	1000	630	630	1000
A/mm ²	24/2,5; 24/2,5			24/2,5; 24/2,5			24/2,5; 24/2,5			24/2,5; 24/2,5			24/2,5; 24/2,5			24/2,5; 24/2,5		
A/AWG	14/12; 14/12			14/12; 14/12			14/12; 14/12			14/12; 14/12			14/12; 14/12			14/12; 14/12		
—	IP 00			IP 00			IP 00			IP 00			IP 00			IP 00		
KV	2			2			3			3			3			3		

mm	2,4x1,5/2,4	2,4x1,5/2,4	2,4x1,5/2,4	2,4x1,5/2,4	2,4x1,5/2,4	2,4x1,5/2,4
mm	0,9x0,9/1,5	0,9x0,9/1,5	0,9x0,9/1,5	0,9x0,9/1,5	0,9x0,9/1,5	0,9x0,9/1,5
—						
Nm						

—	PA - UL94 V0	PA - UL94 V0	PA - UL94 V0	PA - UL94 V0	PA - UL94 V0	PA - UL94 V0
—	CuZn 39 Pb2 / Ni + Sn	CuZn 39 Pb2 / Ni + Sn	CuZn 39 Pb2 / Ni + Sn	CuZn 39 Pb2 / Ni + Sn	CuZn 39 Pb2 / Ni + Sn	CuZn 39 Pb2 / Ni + Sn
—	CuZn 37 / Ni + Sn	CuZn 37 / Ni + Sn	CuZn 37 / Ni + Sn	CuZn 37 / Ni + Sn	CuZn 37 / Ni + Sn	CuZn 37 / Ni + Sn
—	—	—	—	—	—	—
—	—	—	—	—	—	—
—	C18 / Zn	C18 / Zn	C18 / Zn	C18 / Zn	C18 / Zn	C18 / Zn

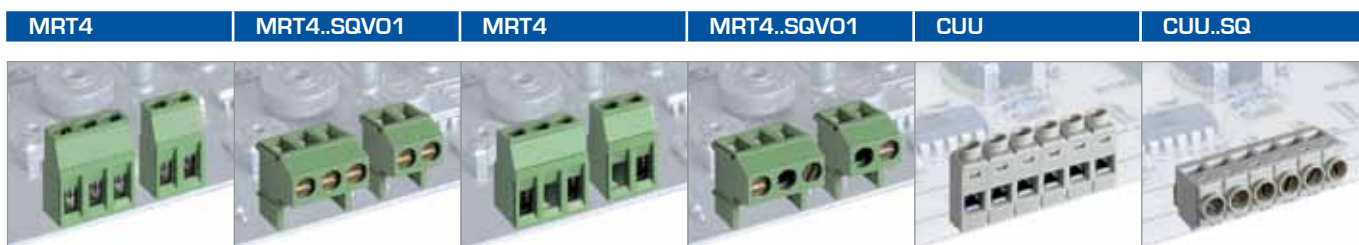

	MRT4		MRT4..SQV01		MRT4		MRT4..SQV01		CUU		CUU..SQ	
mm	5	5	5	5	10	10	10	10	5	5	5	5

	MRT4			MRT4..SQV01			MRT4			MRT4..SQV01			CUU			CUU..SQ		
KV	4	4	4	4	4	4	6	6	6	6	6	6	4	4	4	4	4	4
—/—	III/3	II/2	II/2	III/3	II/2	II/2	III/3	II/2	II/2	III/3	II/2	II/2	III/3	II/2	II/2	III/3	II/2	II/2
V	250	500	630	250	500	630	630	630	1000	630	630	1000	250	400	630	250	400	630
A/mm ²	24/2,5; 24/2,5			24/2,5; 24/2,5			24/2,5; 24/2,5			24/2,5; 24/2,5			22/2,5; 22/2,5			22/2,5; 22/2,5		
A/AWG	16/12; 16/12			16/12; 16/12			16/12; 16/12			16/12; 16/12			16/12; 16/12			16/12; 16/12		
—	IP 00			IP 00			IP 00			IP 00			IP 00			IP 00		
KV	2			2			3			3			2,5			2,5		

mm	2,8x2,4/2,4	2,8x2,4/2,4	2,8x2,4/2,4	2,8x2,4/2,4	2,8x2,4/2,4	2,8x2,4/2,4
mm	1,2x0,9/1,5	1,2x0,9/1,5	1,2x0,9/1,5	1,2x0,9/1,5	1,2x0,9/1,5	1x0,7/1,3
—						
Nm						

—	PA - UL94 V0	PA - UL94 V0	PA - UL94 V0	PA - UL94 V0	PA - UL94 V0	PC - UL94 V0	PC - UL94 V0
—	CuZn 39 Pb2 / Ni + Sn	CuZn 39 Pb2 / Ni + Sn	CuZn 39 Pb2 / Ni + Sn	CuZn 39 Pb2 / Ni + Sn	CuZn 39 Pb2 / Ni + Sn	C60 / Zn	C60 / Zn
—	CuZn 37 / Ni + Sn	CuZn 37 / Ni + Sn	CuZn 37 / Ni + Sn	CuZn 37 / Ni + Sn	CuZn 37 / Ni + Sn	CuZn 37 / Ni + Sn	CuZn 37 / Ni + Sn
—	—	—	—	—	—	—	—
—	—	—	—	—	—	—	—
—	C18 / Zn	C18 / Zn	C18 / Zn	C18 / Zn	C18 / Zn	C18 / Zn	C18 / Zn

Morsetti per C.S. a carrello
 Blocs de jonction C.I. étrier remontant

Terminal blocks for P.C.B. rising clamp
 Printklemmen Liftprinzip



	CUU			CUU..SQ			MRT5			MRT5..SQ			MRT5..DP			MRT5		
mm	A1 10			A1 10			A1 5 5,08			A1 5 5,08			A1 5 5,08			A1 7,5 7,62		

	CUU			CUU..SQ			MRT5			MRT5..SQ			MRT5..DP			MRT5		
KV	6 6 6			6 6 6			4 4 4			4 4 4			4 4 4			6 6 6		
—/—	III/3 III/2 II/2			III/3 III/2 II/2			III/3 III/2 II/2			III/3 III/2 II/2			III/3 III/2 II/2			III/3 III/2 II/2		
V	500 630 800			500 630 800			320 500 630			320 500 630			320 500 630			500 630 1000		
A/mm²	22/2,5; 22/2,5			22/2,5; 22/2,5			24/2,5; 24/2,5			24/2,5; 24/2,5			24/2,5; 24/2,5			24/2,5; 24/2,5		
A/AWG	16/12; 16/12			16/12; 16/12			16/12; 16/12			16/12; 16/12			16/12; 16/12			16/12; 16/12		
—	IP 00			IP 00			IP 00			IP 00			IP 00			IP 00		
KV	3			3			2,5			2,5			2,5			3		

mm	2,8x2,4/2,4			2,8x2,4/2,4			2,8x2,4/2,4			2,8x2,4/2,4			2,8x2,4/2,4			2,8x2,4/2,4		
mm	1x0,7/1,3			1x0,7/1,3			0,9x0,9/1,5			0,9x0,9/1,5			0,9x0,9/1,5			0,9x0,9/1,5		
Nm																		

—	PC - UL94 V0			PC - UL94 V0			PA - UL94 V0			PA - UL94 V0			PA - UL94 V0			PA - UL94 V0		
—	C60 / Zn			C60 / Zn			CuZn 39 Pb2 / Ni + Sn			CuZn 39 Pb2 / Ni + Sn			CuZn 39 Pb2 / Ni + Sn			CuZn 39 Pb2 / Ni + Sn		
—	CuZn 37 / Ni + Sn			CuZn 37 / Ni + Sn			CuZn 37 / Ni + Sn			CuZn 37 / Ni + Sn			CuZn 37 / Ni + Sn			CuZn 37 / Ni + Sn		
—	—			—			—			—			—			—		
—	—			—			—			—			—			—		
—	C18 / Zn			C18 / Zn			C18 / Zn			C18 / Zn			C18 / Zn			C18 / Zn		

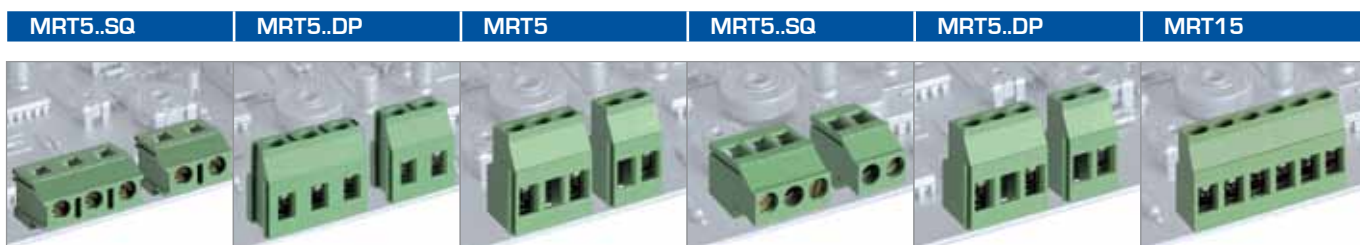

	MRT5..SQ			MRT5..DP			MRT5			MRT5..SQ			MRT5..DP			MRT15		
mm	A1 7,5 7,62			A1 7,5 7,62			A1 10 10,16			A1 10 10,16			A1 10 10,16			A1 5 5,08		

	MRT5..SQ			MRT5..DP			MRT5			MRT5..SQ			MRT5..DP			MRT15		
KV	6 6 6			6 6 6			6 6 6			6 6 6			6 6 6			4 4 4		
—/—	III/3 III/2 II/2			III/3 III/2 II/2			III/3 III/2 II/2			III/3 III/2 II/2			III/3 III/2 II/2			III/3 III/2 II/2		
V	500 630 1000			500 630 1000			630 630 1000			630 630 1000			630 630 1000			320 500 630		
A/mm²	24/2,5; 24/2,5			24/2,5; 24/2,5			24/2,5; 24/2,5			24/2,5; 24/2,5			24/2,5; 24/2,5			24/2,5; 24/2,5		
A/AWG	16/12; 16/12			16/12; 16/12			16/12; 16/12			16/12; 16/12			16/12; 16/12			16/12; 16/12		
—	IP 00			IP 00			IP 00			IP 00			IP 00			IP 00		
KV	3			3			3			3			3			2,5		

mm	2,8x2,4/2,4			2,8x2,4/2,4			2,8x2,4/2,4			2,8x2,4/2,4			2,8x2,4/2,4			2,8x2,4/2,4		
mm	0,9x0,9/1,5			0,9x0,9/1,5			0,9x0,9/1,5			0,9x0,9/1,5			0,9x0,9/1,5			0,9x0,9/1,5		
Nm																		

—	PA - UL94 V0			PA - UL94 V0			PA - UL94 V0			PA - UL94 V0			PA - UL94 V0			PA - UL94 V0		
—	CuZn 39 Pb2 / Ni + Sn			CuZn 39 Pb2 / Ni + Sn			CuZn 39 Pb2 / Ni + Sn			CuZn 39 Pb2 / Ni + Sn			CuZn 39 Pb2 / Ni + Sn			CuZn 39 Pb2 / Ni + Sn		
—	CuZn 37 / Ni + Sn			CuZn 37 / Ni + Sn			CuZn 37 / Ni + Sn			CuZn 37 / Ni + Sn			CuZn 37 / Ni + Sn			CuZn 37 / Ni + Sn		
—	—			—			—			—			—			—		
—	—			—			—			—			—			—		
—	C18 / Zn			C18 / Zn			C18 / Zn			C18 / Zn			C18 / Zn			C18 / Zn		

D/
A1

Morsetti per C.S. a carrello
 Blocs de jonction C.I. étrier remontant

Terminal blocks for P.C.B. rising clamp
 Printklemmen Liftprinzip

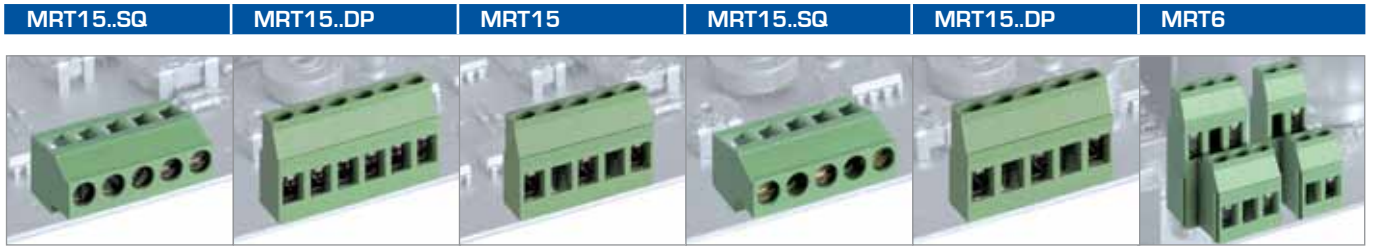

	MRT15..SQ		MRT15..DP		MRT15		MRT15..SQ		MRT15..DP		MRT6	
mm	5 5,08		5 5,08		10 10,16		10 10,16		10 10,16		5	

	MRT15..SQ			MRT15..DP			MRT15			MRT15..SQ			MRT15..DP			MRT6		
KV	4 4 4			4 4 4			6 6 6			6 6 6			6 6 6			4 4 4		
—/—	III/3 III/2 II/2			III/3 III/2 II/2			III/3 III/2 II/2			III/3 III/2 II/2			III/3 III/2 II/2			III/3 III/2 II/2		
V	320 500 630			320 500 630			630 630 1000			630 630 1000			630 630 1000			320 500 630		
A/mm²	24/2,5; 24/2,5			24/2,5; 24/2,5			24/2,5; 24/2,5			24/2,5; 24/2,5			24/2,5; 24/2,5			24/2,5; 24/2,5		
A/AWG	16/12; 16/12			16/12; 16/12			16/12; 16/12			16/12; 16/12			16/12; 16/12			16/12; 16/12		
—	IP 00			IP 00			IP 00			IP 00			IP 00			IP 00		
KV	2,5			2,5			3			3			3			2,5		

mm	2,8x2,4/2,4		2,8x2,4/2,4		2,8x2,4/2,4		2,8x2,4/2,4		2,8x2,4/2,4		2,8x2,4/2,4	
mm	0,9X0,9/1,5		0,9X0,9/1,5		0,9X0,9/1,5		0,9X0,9/1,5		0,9X0,9/1,5		0,9X0,9/1,5	
Nm												

—	PA - UL94 V0		PA - UL94 V0		PA - UL94 V0		PA - UL94 V0		PA - UL94 V0		PA - UL94 V0	
—	CuZn 39 Pb2 / Ni + Sn		CuZn 39 Pb2 / Ni + Sn		CuZn 39 Pb2 / Ni + Sn		CuZn 39 Pb2 / Ni + Sn		CuZn 39 Pb2 / Ni + Sn		CuZn 39 Pb2 / Ni + Sn	
—	CuZn 37 / Ni + Sn		CuZn 37 / Ni + Sn		CuZn 37 / Ni + Sn		CuZn 37 / Ni + Sn		CuZn 37 / Ni + Sn		CuZn 37 / Ni + Sn	
—	—		—		—		—		—		—	
—	—		—		—		—		—		—	
—	C18 / Zn		C18 / Zn		C18 / Zn		C18 / Zn		C18 / Zn		C18 / Zn	

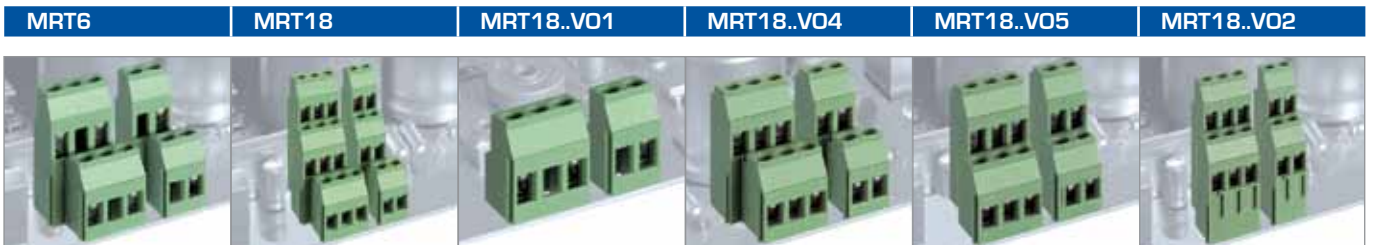

	MRT6		MRT18		MRT18..VO1		MRT18..VO4		MRT18..VO5		MRT18..VO2	
mm	10		5,08 10,16*		5,08 10,16*		5,08 10,16*		5,08 10,16*		5,08 10,16*	

	MRT6			MRT18			MRT18..VO1			MRT18..VO4			MRT18..VO5			MRT18..VO2		
KV	6 6 6			4/6* 4/6* 4/6*			4/6* 4/6* 4/6*			4/6* 4/6* 4/6*			4/6* 4/6* 4/6*			4/6* 4/6* 4/6*		
—/—	III/3 III/2 II/2			III/3 III/2 II/2			III/3 III/2 II/2			III/3 III/2 II/2			III/3 III/2 II/2			III/3 III/2 II/2		
V	630 630 1000			320/630* 500/630* 630/1000*			320/630* 500/630* 630/1000*			320/630* 500/630* 630/1000*			320/630* 500/630* 630/1000*			320/630* 500/630* 630/1000*		
A/mm²	24/2,5; 24/2,5			20/2,5; 20/2,5			20/2,5; 20/2,5			20/2,5; 20/2,5			20/2,5; 20/2,5			20/2,5; 20/2,5		
A/AWG	16/12; 16/12			16/12; 16/12			16/12; 16/12			16/12; 16/12			16/12; 16/12			16/12; 16/12		
—	IP 00			IP 00			IP 00			IP 00			IP 00			IP 00		
KV	3			2,5/3*			2,5/3*			2,5/3*			2,5/3*			2,5/3*		

mm	2,8x2,4/2,4		2,8x2,4/2,4		2,8x2,4/2,4		2,8x2,4/2,4		2,8x2,4/2,4		2,8x2,4/2,4	
mm	0,9X0,9/1,5		0,9X0,9/1,5		0,9X0,9/1,5		0,9X0,9/1,5		0,9X0,9/1,5		0,9X0,9/1,5	
Nm												

—	PA - UL94 V0		PA - UL94 V0		PA - UL94 V0		PA - UL94 V0		PA - UL94 V0		PA - UL94 V0	
—	CuZn 39 Pb2 / Ni + Sn		CuZn 39 Pb2 / Ni + Sn		CuZn 39 Pb2 / Ni + Sn		CuZn 39 Pb2 / Ni + Sn		CuZn 39 Pb2 / Ni + Sn		CuZn 39 Pb2 / Ni + Sn	
—	CuZn 37 / Ni + Sn		CuZn 37 / Ni + Sn		CuZn 37 / Ni + Sn		CuZn 37 / Ni + Sn		CuZn 37 / Ni + Sn		CuZn 37 / Ni + Sn	
—	—		—		—		—		—		—	
—	—		—		—		—		—		—	
—	C18 / Zn		C18 / Zn		C18 / Zn		C18 / Zn		C18 / Zn		C18 / Zn	

D/
A1

Morsetti per C.S. a carrello
 Blocs de jonction C.I. étrier remontant

Terminal blocks for P.C.B. rising clamp
 Printklemmen Liftprinzip

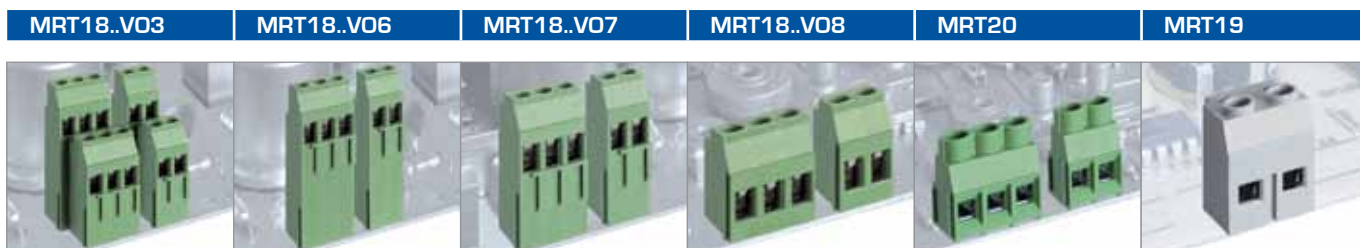

	MRT18..V03		MRT18..V06		MRT18..V07		MRT18..V08		MRT20		MRT19
mm	5,08 10,16*		5,08 10,16*		5,08 10,16*		5,08 10,16*		6,35 9,52*		8

	MRT18..V03			MRT18..V06			MRT18..V07			MRT18..V08			MRT20			MRT19		
KV	4/6*			4/6*			4/6*			4/6*			6			6		
—/—	III/3			III/2			II/2			III/3			III/2			II/2		
V	320/630*			500/630*			630/1000*			320/630*			500/630*			630/1000*		
A/mm ²	20/2,5; 20/2,5			20/2,5; 20/2,5			20/2,5; 20/2,5			20/2,5; 20/2,5			24/4; 24/4			24/4; 24/4		
A/AWG	16/12; 16/12			16/12; 16/12			16/12; 16/12			16/12; 16/12			30/10; 30/10			16/12; 16/12		
—	IP 00			IP 00			IP 00			IP 00			IP 00			IP 00		
KV	2,5/3*			2,5/3*			2,5/3*			2,5/3*			2,5/3*			3		

mm	2,8x2,4/2,4	2,8x2,4/2,4	2,8x2,4/2,4	2,8x2,4/2,4	3,6x3,1/3,0	2,8x2,4/3,0
mm	0,9x0,9/1,5	0,9x0,9/1,5	0,9x0,9/1,5	0,9x0,9/1,5	0,9x0,9/1,5	1x0,8/1,3
Nm						

—	PA - UL94 V0	PA - UL94 V0	PA - UL94 V0	PA - UL94 V0	PA - UL94 V0	PA - UL94 V0
—	CuZn 39 Pb2 / Ni + Sn	CuZn 39 Pb2 / Ni + Sn	CuZn 39 Pb2 / Ni + Sn	CuZn 39 Pb2 / Ni + Sn	C60 / Zn	C60 / Zn
—	CuZn 37 / Ni + Sn	CuZn 37 / Ni + Sn	CuZn 37 / Ni + Sn	CuZn 37 / Ni + Sn	CuZn 37 / Ni + Sn	CuZn 37 / Ni + Sn
—	—	—	—	—	—	—
—	—	—	—	—	—	—
—	C18 / Zn	C18 / Zn	C18 / Zn	C18 / Zn	C18 / Zn	C18 / Zn

MRT26 **MRT27**



	MRT26			MRT27		
mm	10,16			10,16		

	MRT26			MRT27		
KV	8			8		
—/—	III/3			III/2		
V	630			1000		
A/mm ²	57/10; 57/10			57/10; 57/10		
A/AWG	58/6; 58/6			60/6; 60/6		
—	IP 00			IP 00		
KV	3			3		

mm	5,4x5,1/5,3	5,4x5,1/5,3
mm	1,2x1,2/1,6	1,2x1,2/1,6
Nm		

—	PA G - UL94 V0	PA G - UL94 V0
—	C60 / Zn	C60 / Zn
—	CuZn 5 / Ni + Sn	CuZn 5 / Ni + Sn
—	—	—
—	—	—
—	C18 / Zn	C18 / Zn

D/
A1

Morsetti per C.S. a linguetta
 Blocs de jonction C.I. languette

Terminal blocks for P.C.B. wire protection
 Printklemmen Drahtschutz



	A2	A2	A2	A2	A2	A2
mm	5	5	10	10	5	5

—	I			I			I			I			I			I		
KV	4	4	4	4	4	4	6	6	6	6	6	6	4	4	4	4	4	4
—/—	III/3	III/2	II/2	III/3	III/2	II/2	III/3	III/2	II/2	III/3	III/2	II/2	III/3	III/2	II/2	III/3	III/2	II/2
V	200	320	320	200	320	320	500	630	800	500	630	800	200	320	320	200	320	320
A/mm ²	13,5/1,5; 13,5/1,5			13,5/1,5; 13,5/1,5			13,5/1,5; 13,5/1,5			13,5/1,5; 13,5/1,5			13,5/1,5; 13,5/1,5			13,5/1,5; 13,5/1,5		
A/AWG	14/14; 14/14			14/14; 14/14			14/14; 14/14			14/14; 14/14			14/14; 14/14			14/14; 14/14		
—	IP 00			IP 00			IP 00			IP 00			IP 00			IP 00		
KV	2			2			3			3			2			2		

mm	—/1,8	—/1,8	—/1,8	—/1,8	—/1,8	—/1,8
mm	Ø 1,0/1,3	Ø 1,0/1,3	Ø 1,0/1,3	Ø 1,0/1,3	Ø 1,0/1,3	Ø 1,0/1,3
—						
Nm						

—	PC - UL94 V0	PC - UL94 V0	PC - UL94 V0	PC - UL94 V0	PC - UL94 V0	PC - UL94 V0
—	CuZn 39 Pb2 / Ni + Sn	CuZn 39 Pb2 / Ni + Sn	CuZn 39 Pb2 / Ni + Sn	CuZn 39 Pb2 / Ni + Sn	CuZn 39 Pb2 / Ni + Sn	CuZn 39 Pb2 / Ni + Sn
—	—	—	—	—	—	—
—	—	—	—	—	—	—
—	CuZn 37 / Sn	CuZn 37 / Sn	CuZn 37 / Sn	CuZn 37 / Sn	CuZn 37 / Sn	CuZn 37 / Sn
—	C18 / Zn	C18 / Zn	C18 / Zn	C18 / Zn	C18 / Zn	C18 / Zn

CZI CZI..SQ MRT12 MRT12 MRT12 CMM

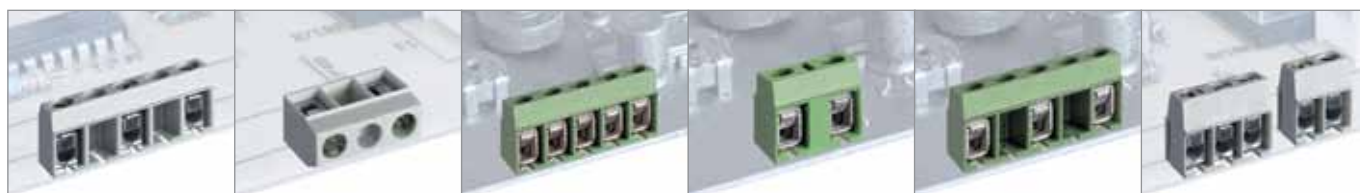

	A2	A2	A2	A2	A2	A2
mm	10	10	5	7,5	10	5

—	I			I			I			I			I			I		
KV	6	6	6	6	6	6	4	4	4	6	6	6	6	6	6	4	4	4
—/—	III/3	III/2	II/2	III/3	III/2	II/2	III/3	III/2	II/2	III/3	III/2	II/2	III/3	III/2	II/2	III/3	III/2	II/2
V	500	630	800	500	630	800	250	400	630	500	630	1000	630	630	1000	250	400	400
A/mm ²	13,5/1,5; 13,5/1,5			13,5/1,5; 13,5/1,5			24/2,5; 24/2,5			24/2,5; 24/2,5			24/2,5; 24/2,5			24/2,5; 24/2,5		
A/AWG	14/14; 14/14			14/14; 14/14			16/12; 16/12			16/12; 16/12			16/12; 16/12			16/14; 16/14		
—	IP 00			IP 00			IP 00			IP 00			IP 00			IP 00		
KV	3			3			2			3			3			2,5		

mm	—/1,8	—/1,8	—/2,0	—/2,0	—/2,0	—/2,2
mm	Ø 1,0/1,3	Ø 1,0/1,3	1,0x0,7/1,3	1,0x0,7/1,3	1,0x0,7/1,3	Ø 1,0/1,3
—						
Nm						

—	PC - UL94 V0	PC - UL94 V0	PA - UL94 V0	PA - UL94 V0	PA - UL94 V0	PC - UL94 V0
—	CuZn 39 Pb2 / Ni + Sn	CuZn 39 Pb2 / Ni + Sn	CuZn 37 / Ni + Sn	CuZn 37 / Ni + Sn	CuZn 37 / Ni + Sn	CuZn 39 Pb2 / Ni + Sn
—	—	—	—	—	—	—
—	—	—	—	—	—	—
—	CuZn 37 / Sn	CuZn 37 / Sn	CuZn 37 / Sn	CuZn 37 / Sn	CuZn 37 / Sn	CuZn 37 / Sn
—	C18 / Zn	C18 / Zn	C18 / Zn	C18 / Zn	C18 / Zn	C18 / Zn

D/
A2



	A2	A2	A2	A2	A2	A2
mm	10	5	5	10	10	5

—	I			I			I			I			I			I		
KV	6	6	6	4	4	4	4	4	4	6	6	6	6	6	6	4	4	4
—/—	III/3	III/2	II/2	III/3	III/2	II/2	III/3	III/2	II/2	III/3	III/2	II/2	III/3	III/2	II/2	III/3	III/2	II/2
V	500	630	800	250	400	400	250	400	400	500	630	800	500	630	800	250	400	630
A/mm²	24/2,5; 24/2,5			24/2,5; 24/2,5			24/2,5; 24/2,5			24/2,5; 24/2,5			24/2,5; 24/2,5			24/2,5; 24/2,5		
A/AWG	16/14; 16/14			16/14; 16/14			16/14; 16/14			16/14; 16/14			16/14; 16/14			18/12; 18/12		
—	IP 00			IP 00			IP 00			IP 00			IP 00			IP 00		
KV	3			2,5			2,5			3			3			2		

mm	—/2,2	—/2,2	—/2,2	—/2,2	—/2,2	—/2,4
mm	Ø 1,0/1,3	Ø 1,0/1,3	Ø 1,0/1,3	Ø 1,0/1,3	Ø 1,0/1,3	1,0x0,7/1,3
—						
Nm						

—	PC - UL94 V0	PC - UL94 V0	PC - UL94 V0	PC - UL94 V0	PC - UL94 V0	PC - UL94 V0
—	CuZn 39 Pb2 / Ni + Sn	CuZn 39 Pb2 / Ni + Sn	CuZn 39 Pb2 / Ni + Sn	CuZn 39 Pb2 / Ni + Sn	CuZn 39 Pb2 / Ni + Sn	CuZn 37 / Ni + Sn
—	—	—	—	—	—	—
—	—	—	—	—	—	—
—	CuZn 37 / Sn	CuZn 37 / Sn	CuZn 37 / Sn	CuZn 37 / Sn	CuZn 37 / Sn	CuZn 37 / Sn
—	C18 / Zn	C18 / Zn	C18 / Zn	C18 / Zn	C18 / Zn	C18 / Zn

CBL



	A2
mm	10

—	I		
KV	6	6	6
—/—	III/3	III/2	II/2
V	500	630	800
A/mm²	24/2,5; 24/2,5		
A/AWG	18/12; 18/12		
—	IP 00		
KV	3		

mm	—/2,4
mm	1x0,7/1,3
—	
Nm	

—	PC - UL94 V0
—	CuZn 37 / Ni + Sn
—	—
—	—
—	CuZn 37 / Sn
—	C18 / Zn

D/
A2

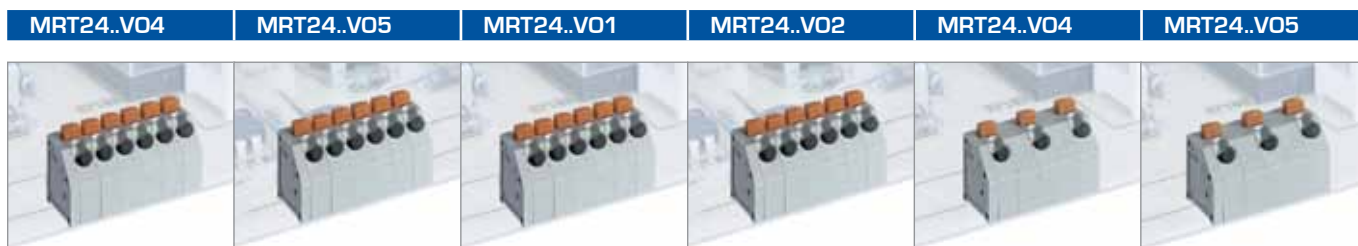

	MRT24..VO4		MRT24..VO5		MRT24..VO1		MRT24..VO2		MRT24..VO4		MRT24..VO5	
mm	A3 3,5 3,81		A3 3,5 3,81		A3 3,5 3,81		A3 3,5 3,81		A3 7 7,62		A3 7 7,62	

	MRT24..VO4			MRT24..VO5			MRT24..VO1			MRT24..VO2			MRT24..VO4			MRT24..VO5		
KV	4	4	4	4	4	4	4	4	4	4	4	4	6	6	6	6	6	6
—/—	III/3	III/2	II/2	III/3	III/2	II/2	III/3	III/2	II/2	III/3	III/2	II/2	III/3	III/2	II/2	III/3	III/2	II/2
V	250	500	630	320	500	630	320	500	630	320	500	630	500	630	1000	500	630	1000
A/mm ²	4/1,5; 4/1,5			4/1,5; 4/1,5			4/1,5; 4/1,5			4/1,5; 4/1,5			4/1,5; 4/1,5			4/1,5; 4/1,5		
A/AWG	4/16; 4/16			4/16; 4/16			4/16; 4/16			4/16; 4/16			4/16; 4/16			4/16; 4/16		
—	IP 00			IP 00			IP 00			IP 00			IP 00			IP 00		
KV	2			2,5			2,5			2,5			2,5			2,5		

mm	-/-1,9		-/-1,9		-/-1,9		-/-1,9		-/-1,9		-/-1,9	
mm	0,8x0,4/1,0		0,8x0,4/1,0		0,8x0,4/1,0		0,8x0,4/1,0		0,8x0,4/1,0		0,8x0,4/1,0	
Nm												

—	PA - UL94 V0	PA - UL94 V0	PA - UL94 V0	PA - UL94 V0	PA - UL94 V0	PA - UL94 V0
—	CuSn 6 / Sn	CuSn 6 / Sn	CuSn 6 / Sn	CuSn 6 / Sn	CuSn 6 / Sn	CuSn 6 / Sn
—	CuSn 6 / Sn	CuSn 6 / Sn	CuSn 6 / Sn	CuSn 6 / Sn	CuSn 6 / Sn	CuSn 6 / Sn
—	—	—	—	—	—	—
—	—	—	—	—	—	—
—	—	—	—	—	—	—



	MRT1		MRT1		MRT1		MRT23		MRT23		CTL	
mm	A3 5 5,08		A3 7,5 7,62		A3 10 10,16		A3 5,08		A3 10,16		A3 5,08	

	MRT1			MRT1			MRT1			MRT23			MRT23			CTL		
KV	4	4	4	6	6	6	6	6	6	4	4	4	6	6	6	4	4	4
—/—	III/3	III/2	II/2	III/3	III/2	II/2	III/3	III/2	II/2	III/3	III/2	II/2	III/3	III/2	II/2	III/3	III/2	II/2
V	250	500	630	500	630	1000	630	630	1000	320	500	630	630	630	1000	250	500	630
A/mm ²	10/1,5; 10/1,5			10/1,5; 10/1,5			10/1,5; 10/1,5			16/1,5; 16/1,5			16/1,5; 16/1,5			10/1,5; 10/1,5		
A/AWG	10/16; 10/16			10/16; 10/16			10/16; 10/16			10/16; 10/16			10/16; 10/16			10/16; 10/16		
—	IP 00			IP 00			IP 00			IP 00			IP 00			IP 00		
KV	2			3			3			2			3			2		

mm	2,4x1,5/1,9		2,4x1,5/1,9		2,4x1,5/1,9		2,4x1,5/2,4		2,4x1,5/2,4		-/-1,9	
mm	0,8x0,4/1,3		0,8x0,4/1,3		0,8x0,4/1,3		1,0x0,8/1,5		1,0x0,8/1,5		1,0x0,5/1,3	
Nm												

—	PA - UL94 V0	PA - UL94 V0	PA - UL94 V0	PA - UL94 V0	PA - UL94 V0	PA - UL94 V0
—	INOX Steel	INOX Steel	INOX Steel	INOX Steel	INOX Steel	INOX Steel
—	CuZn 37 / Ni + Sn	CuZn 37 / Ni + Sn	CuZn 37 / Ni + Sn	CuZn 37 / Ni + Sn	CuZn 37 / Ni + Sn	CuZn 37 / Ni + Sn
—	—	—	—	—	—	—
—	—	—	—	—	—	—
—	—	—	—	—	—	—

D/
A3

Morsetti per C.S. a molla
 Blocs de jonction C.I. ressort

Terminal blocks for P.C.B. screwless
 Printklemmen Federkraft

CTL



	A3
mm	10,16

—	I		
KV	6	6	6
—/—	III/3	III/2	II/2
V	630	630	1000
A/mm²	10/1,5 ; 10/1,5		
A/AWG	10/16 ; 10/16		
—	IP 00		
KV	3		

mm	—/1,9
mm	1,0x0,5/1,3
—	
Nm	

—	PA - UL94 V0
—	INOX Steel
—	CuZn 37 / Ni + Sn
—	—
—	—
—	—

D/
A3

Connettori femmina a carrello

Connecteurs femelle étrier remontant

Female plug rising clamp

Steckerteil-Liftprinzip

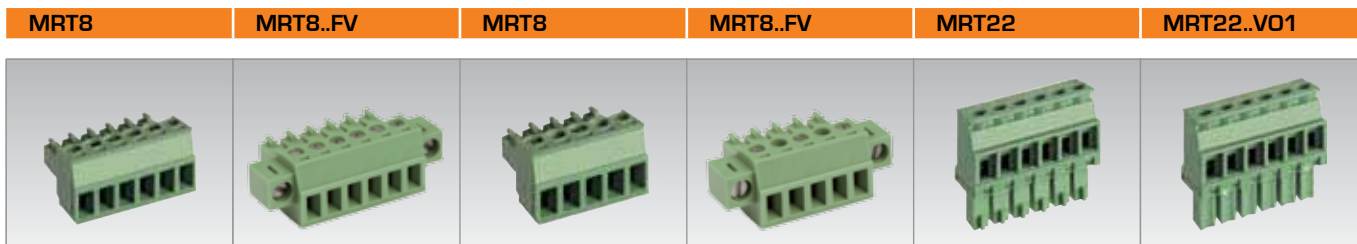

	MRT8		MRT8..FV		MRT8		MRT8..FV		MRT22		MRT22..VO1	
	B1		B1		B1		B1		B1		B1	
mm	3,5	3,81	3,5	3,81	7	7,62*	7	7,62*	3,5	3,81	3,5	3,81

	MRT8			MRT8..FV			MRT8			MRT8..FV			MRT22			MRT22..VO1		
	I			I			I			I			I			I		
KV	2,5	2,5	2,5	2,5	2,5	2,5	4	4	4	4	4	4	2,5	2,5	2,5	2,5	2,5	2,5
—/—	III/3	III/2	II/2	III/3	III/2	II/2	III/3	III/2	II/2	III/3	III/2	II/2	III/3	III/2	II/2	III/3	III/2	II/2
V	200	250	500	200	250	500	400/500*	500/500*	630/630*	400/500*	500/500*	630/630*	200	250	500	200	250	500
A/mm ²	10/1,0; 10/1,0			10/1,0; 10/1,0			10/1,0; 10/1,0			10/1,0; 10/1,0			10/1,0; 10/1,0			10/1,0; 10/1,0		
A/AWG	8/16; 8/16			8/16; 8/16			8/16; 8/16			8/16; 8/16			8/16; 8/16			8/16; 8/16		
—	IP 00			IP 00			IP 00			IP 00			IP 00			IP 00		
KV	1,25			1,25			2,5			2,5			1,25			2,5		

mm	2,4x1,5/1,6	2,4x1,5/1,6	2,4x1,5/1,6	2,4x1,5/1,6	2,4x1,5/1,6	2,4x1,5/1,6
mm	—	—	—	—	—	—
—	M 2,5		M 2,5		M 2,5	
Nm	0,3		0,3		0,3	

—	PA - UL94 V0	PA - UL94 V0	PA - UL94 V0	PA - UL94 V0	PA - UL94 V0	PA - UL94 V0
—	CuZn 39 Pb2 / Ni + Sn	CuZn 39 Pb2 / Ni + Sn	CuZn 39 Pb2 / Ni + Sn	CuZn 39 Pb2 / Ni + Sn	CuZn 39 Pb2 / Ni + Sn	CuZn 39 Pb2 / Ni + Sn
—	—	—	—	—	—	—
—	CuSn 6 / Ni + Sn	CuSn 6 / Ni + Sn	CuSn 6 / Ni + Sn	CuSn 6 / Ni + Sn	CuSn 6 / Ni + Sn	CuSn 6 / Ni + Sn
—	—	—	—	—	—	—
—	CB / Zn	CB / Zn	CB / Zn	CB / Zn	CB / Zn	CB / Zn

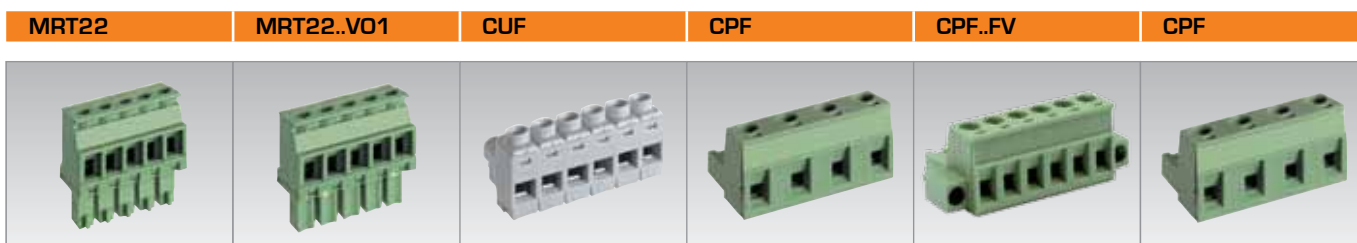

	MRT22		MRT22..VO1		CUF		CPF		CPF..FV		CPF	
	B1		B1		B1		B1		B1		B1	
mm	7	7,62*	7	7,62*	5	10*	5	5,08	5	5,08	7,5	7,62

	MRT22			MRT22..VO1			CUF			CPF			CPF..FV			CPF		
	I			I			I			I			I			I		
KV	4	4	4	4	4	4	4/6*	4/6*	4/6*	4	4	4	4	4	4	6	6	6
—/—	III/3	III/2	II/2	III/3	III/2	II/2	III/3	III/2	II/2	III/3	III/2	II/2	III/3	III/2	II/2	III/3	III/2	II/2
V	400/500*	500/500*	630/630*	400/500*	500/500*	630/630*	250/500*	400/630*	400/800*	320	500	800	320	500	800	500	630	1000
A/mm ²	10/1,0; 10/1,0			10/1,0; 10/1,0			16/2,5; 16/2,5			20/2,5; 20/2,5			20/2,5; 20/2,5			20/2,5; 20/2,5		
A/AWG	8/16; 8/16			8/16; 8/16			14/12; 14/12			12/12; 12/12			12/12; 12/12			12/12; 12/12		
—	IP 00			IP 00			IP 00			IP 00			IP 00			IP 00		
KV	2,5			2,5			2,5/3*			2,5			2,5			3		

mm	2,4x1,5/1,6	2,4x1,5/1,6	2,8x2,4/2,4	2,8x2,4/2,4	2,8x2,4/2,4	2,8x2,4/2,4
mm	—	—	—	—	—	—
—	M 2,5		M 2,5		M 2,5	
Nm	0,3		0,3		0,3	

—	PA - UL94 V0	PA - UL94 V0	PC - UL94 V0	PA - UL94 V0	PA - UL94 V0	PA - UL94 V0
—	CuZn 39 Pb2 / Ni + Sn	CuZn 39 Pb2 / Ni + Sn	CB0 / Zn	CuZn 39 Pb2 / Ni + Sn	CuZn 39 Pb2 / Ni + Sn	CuZn 39 Pb2 / Ni + Sn
—	—	—	—	—	—	—
—	CuSn 6 / Ni + Sn	CuSn 6 / Ni + Sn	CuSn 6 / Ni + Sn	CuSn 6 / Ni + Sn	CuSn 6 / Ni + Sn	CuSn 6 / Ni + Sn
—	—	—	—	—	—	—
—	CB / Zn	CB / Zn	CB / Zn	CB / Zn	CB / Zn	CB / Zn

Connettori femmina a carrello

Connecteurs femelle étrier remontant

Female plug rising clamp

Steckerteil-Liftprinzip

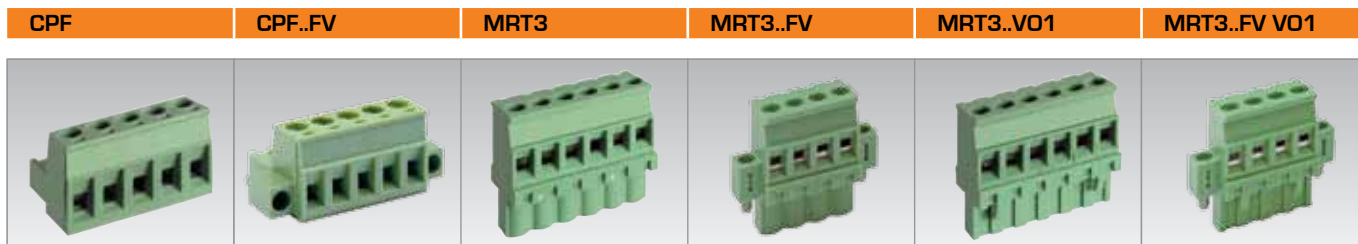

	CPF		CPF..FV		MRT3		MRT3..FV		MRT3..VO1		MRT3..FV VO1	
mm	10	10,16	10	10,16	5	5,08	5	5,08	5	5,08	5	5,08

	I			I			I			I			I			I		
KV	6	6	6	6	6	6	4	4	4	4	4	4	4	4	4	4	4	
—/—	III/3	III/2	II/2	III/3	III/2	II/2	III/3	III/2	II/2	III/3	III/2	II/2	III/3	III/2	II/2	III/3	III/2	
V	630	800	1000	630	800	1000	320	500	800	320	500	800	320	500	800	320	500	
A/mm ²	20/2,5; 20/2,5			20/2,5; 20/2,5			20/2,5; 20/2,5			20/2,5; 20/2,5			20/2,5; 20/2,5			20/2,5; 20/2,5		
A/AWG	12/12; 12/12			12/12; 12/12			12/12; 12/12			12/12; 12/12			12/12; 12/12			12/12; 12/12		
—	IP 00			IP 00			IP 00			IP 00			IP 00			IP 00		
KV	3			3			2,5			2,5			2,5			2,5		

mm	2,8x2,4/2,4	2,8x2,4/2,4	2,8x2,4/2,4	2,8x2,4/2,4	2,8x2,4/2,4	2,8x2,4/2,4
mm	—	—	—	—	—	—
—	—	M 2,5	—	—	M 2,5	—
Nm	—	0,3	—	—	0,3	—

—	PA - UL94 V0	PA - UL94 V0	PA - UL94 V0	PA - UL94 V0	PA - UL94 V0	PA - UL94 V0
—	CuZn 39 Pb2 / Ni + Sn	CuZn 39 Pb2 / Ni + Sn	CuZn 39 Pb2 / Ni + Sn	CuZn 39 Pb2 / Ni + Sn	CuZn 39 Pb2 / Ni + Sn	CuZn 39 Pb2 / Ni + Sn
—	—	—	—	—	—	—
—	CuSn 6 / Ni + Sn	CuSn 6 / Ni + Sn	CuSn 6 / Ni + Sn	CuSn 6 / Ni + Sn	CuSn 6 / Ni + Sn	CuSn 6 / Ni + Sn
—	—	—	—	—	—	—
—	CB / Zn	CB / Zn	CB / Zn	CB / Zn	CB / Zn	CB / Zn

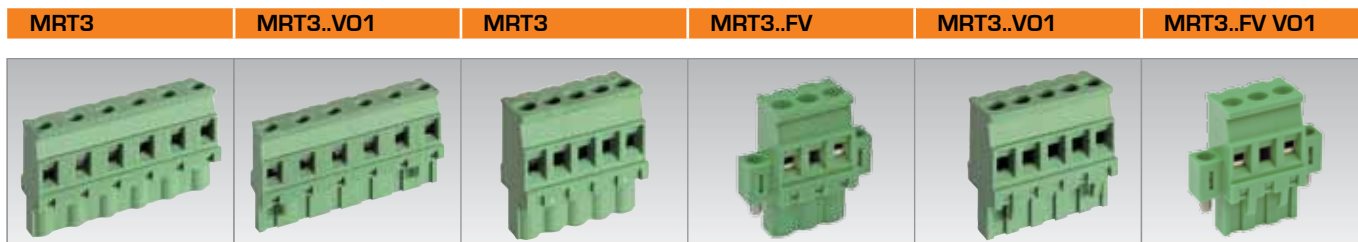

	MRT3		MRT3..VO1		MRT3		MRT3..FV		MRT3..VO1		MRT3..FV VO1	
mm	7,62	7,62	10	10,16	10	10,16	10	10,16	10	10,16	10	10,16

	I			I			I			I			I			I		
KV	6	6	6	6	6	6	6	6	6	6	6	6	6	6	6	6	6	
—/—	III/3	III/2	II/2	III/3	III/2	II/2	III/3	III/2	II/2	III/3	III/2	II/2	III/3	III/2	II/2	III/3	III/2	
V	500	630	1000	500	630	1000	630	800	1000	630	800	1000	630	800	1000	630	800	
A/mm ²	20/2,5; 20/2,5			20/2,5; 20/2,5			20/2,5; 20/2,5			20/2,5; 20/2,5			20/2,5; 20/2,5			20/2,5; 20/2,5		
A/AWG	12/12; 12/12			12/12; 12/12			12/12; 12/12			12/12; 12/12			12/12; 12/12			12/12; 12/12		
—	IP 00			IP 00			IP 00			IP 00			IP 00			IP 00		
KV	3			3			3			3			3			3		

mm	2,8x2,4/2,4	2,8x2,4/2,4	2,8x2,4/2,4	2,8x2,4/2,4	2,8x2,4/2,4	2,8x2,4/2,4
mm	—	—	—	—	—	—
—	—	M 2,5	—	—	M 2,5	—
Nm	—	0,3	—	—	0,3	—

—	PA - UL94 V0	PA - UL94 V0	PA - UL94 V0	PA - UL94 V0	PA - UL94 V0	PA - UL94 V0
—	CuZn 39 Pb2 / Ni + Sn	CuZn 39 Pb2 / Ni + Sn	CuZn 39 Pb2 / Ni + Sn	CuZn 39 Pb2 / Ni + Sn	CuZn 39 Pb2 / Ni + Sn	CuZn 39 Pb2 / Ni + Sn
—	—	—	—	—	—	—
—	CuSn 6 / Ni + Sn	CuSn 6 / Ni + Sn	CuSn 6 / Ni + Sn	CuSn 6 / Ni + Sn	CuSn 6 / Ni + Sn	CuSn 6 / Ni + Sn
—	—	—	—	—	—	—
—	CB / Zn	CB / Zn	CB / Zn	CB / Zn	CB / Zn	CB / Zn

D/
B1

Connettori femmina a molla
Connecteurs femelle à ressort

Female plug screwless
Steckerteil-Federkraft

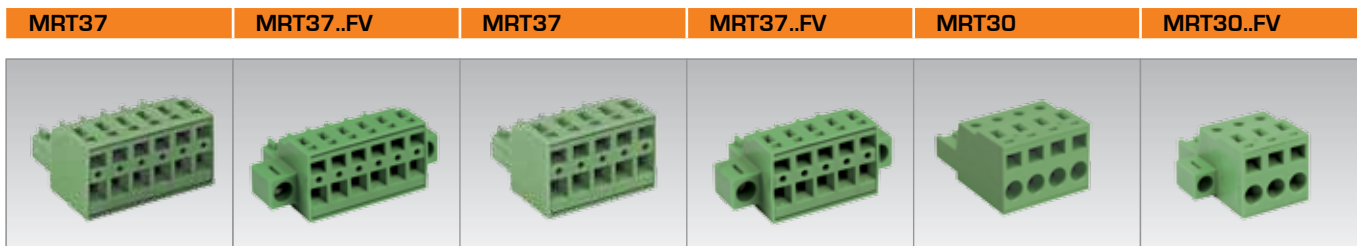

	B2	B2	B2	B2	B2	B2
mm	3,81	3,81	7,62	7,62	5,08	5,08

—	I			I			I			I			I			I		
KV	2,5	2,5	2,5	2,5	2,5	2,5	4	4	4	4	4	4	4	4	4	4	4	
—/—	III/3	III/2	II/2	III/3	III/2	II/2	III/3	III/2	II/2	III/3	III/2	II/2	III/3	III/2	II/2	III/3	III/2	
V	200	250	500	200	250	500	500	800	800	500	800	250	800	320	500	800	320	500
A/mm ²	14/1,5; 14/1,5			14/1,5; 14/1,5			14/1,5; 14/1,5			14/1,5; 14/1,5			18/2,5; 18/2,5			18/2,5; 18/2,5		
A/AWG	8/16; 8/16			8/16; 8/16			8/16; 8/16			8/16; 8/16			12/12; 12/12			12/12; 12/12		
—	IP 00			IP 00			IP 00			IP 00			IP 00			IP 00		
KV	1,25			1,25			2,5			2,5			2,5			2,5		

mm	2,4x1,5/1,6	2,4x1,5/1,6	2,4x1,5/1,6	2,4x1,5/1,6	2,8x2,4/2,4	2,8x2,4/2,4
mm	—	—	—	—	—	—
—	M 2,5			M 2,5		
Nm	0,3			0,3		

—	PA - UL94 V0	PA - UL94 V0	PA - UL94 V0	PA - UL94 V0	PA - UL94 V0	PA - UL94 V0
—	CuZn 39 Pb2 / Ni + Sn	CuZn 39 Pb2 / Ni + Sn	CuZn 39 Pb2 / Ni + Sn	CuZn 39 Pb2 / Ni + Sn	CuZn 39 Pb2 / Ni + Sn	CuZn 39 Pb2 / Ni + Sn
—	—	—	—	—	—	—
—	CuSn 6 / Ni + Sn	CuSn 6 / Ni + Sn	CuSn 6 / Ni + Sn	CuSn 6 / Ni + Sn	CuSn 6 / Ni + Sn	CuSn 6 / Ni + Sn
—	—	—	—	—	—	—
—	CB / Zn	CB / Zn	CB / Zn	CB / Zn	CB / Zn	CB / Zn

MRT30 **MRT30..FV**

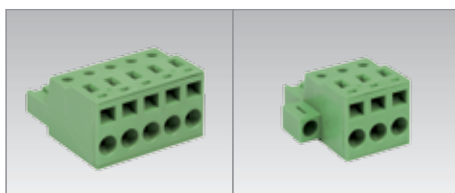

	B2	B2
mm	10,16	10,16

—	I			I		
KV	6	6	6	6	6	6
—/—	III/3	III/2	II/2	III/3	III/2	II/2
V	630	800	1000	630	800	1000
A/mm ²	18/2,5; 18/2,5			18/2,5; 18/2,5		
A/AWG	12/12; 12/12			12/12; 12/12		
—	IP 00			IP 00		
KV	3			3		

mm	2,8x2,4/2,4	2,8x2,4/2,4
mm	—	—
—	M 2,5	
Nm	0,3	

—	PA - UL94 V0	PA - UL94 V0
—	CuZn 39 Pb2 / Ni + Sn	CuZn 39 Pb2 / Ni + Sn
—	—	—
—	CuSn 6 / Ni + Sn	CuSn 6 / Ni + Sn
—	—	—
—	CB / Zn	CB / Zn

D/
B2

Connettori femmina a linguetta

Connecteurs femelle à languette

Female plug wire protection

Steckerteil-Drahtschutz



	CHF	CHF
mm	5	10

	B3			B3		
KV	4	4	4	6	6	6
—/—	III/3	III/2	II/2	III/3	III/2	II/2
V	250	500	630	630	630	1000
A/mm ²	10/1,5; 10/1,5			10/1,5; 10/1,5		
A/AWG	10/14; 10/14			10/14; 10/14		
—	IP 00			IP 00		
KV	2			3		

mm	—/2,0	—/2,0
mm	—	—
—		
Nm		

—	PA - UL94 V0	PA - UL94 V0
—	CuZn 39 Pb2 / Ni + Sn	CuZn 39 Pb2 / Ni + Sn
—	—	—
—	—	—
—	CuSn 6	CuSn 6
—	CB / Zn	CB / Zn

D/
B3

Connettori maschio per C.S.
Connecteurs mâle pour C.I.

Headers for P.C.B.
Stiftleiste für Leiterplatten

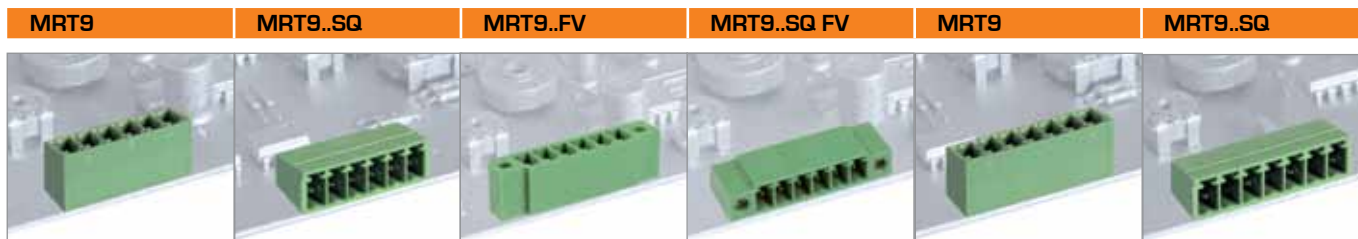

	B4		B4		B4		B4		B4		B4	
mm	3,5	3,81	3,5	3,81	3,5	3,81	3,5	3,81	7	7,62*	7	7,62*

	I			I			I			I			I			I		
KV	2,5	2,5	2,5	2,5	2,5	2,5	2,5	2,5	2,5	2,5	2,5	2,5	4	4	4	4	4	4
—/—	III/3	III/2	II/2	III/3	III/2	II/2	III/3	III/2	II/2	III/3	III/2	II/2	III/3	III/2	II/2	III/3	III/2	II/2
V	200	250	500	200	250	500	200	250	500	200	250	500	400/500*	500/500*	630/630*	400/500*	500/500*	630/630*
A/mm ²	10/1,0; 10/1,0			10/1,0; 10/1,0			10/1,0; 10/1,0			10/1,0; 10/1,0			10/1,0; 10/1,0			10/1,0; 10/1,0		
A/AWG	8/16; 8/16			8/16; 8/16			8/16; 8/16			8/16; 8/16			8/16; 8/16			8/16; 8/16		
—	IP 00			IP 00			IP 00			IP 00			IP 00			IP 00		
KV	1,25			1,25			1,25			1,25			2,5/3*			2,5/3*		

mm	—	—	—	—	—	—
mm	0,8x0,8/1,3	0,8x0,8/1,3	0,8x0,8/1,3	0,8x0,8/1,3	0,8x0,8/1,3	0,8x0,8/1,3
—	—	—	—	—	—	—
Nm	—	—	—	—	—	—

—	PA - UL94 V0	PA - UL94 V0	PA - UL94 V0	PA - UL94 V0	PA - UL94 V0	PA - UL94 V0
—	—	—	—	—	—	—
—	CuSn 6 / Ni + Sn	CuSn 6 / Ni + Sn	CuSn 6 / Ni + Sn	CuSn 6 / Ni + Sn	CuSn 6 / Ni + Sn	CuSn 6 / Ni + Sn
—	—	—	—	—	—	—
—	—	—	—	—	—	—
—	—	—	—	—	—	—

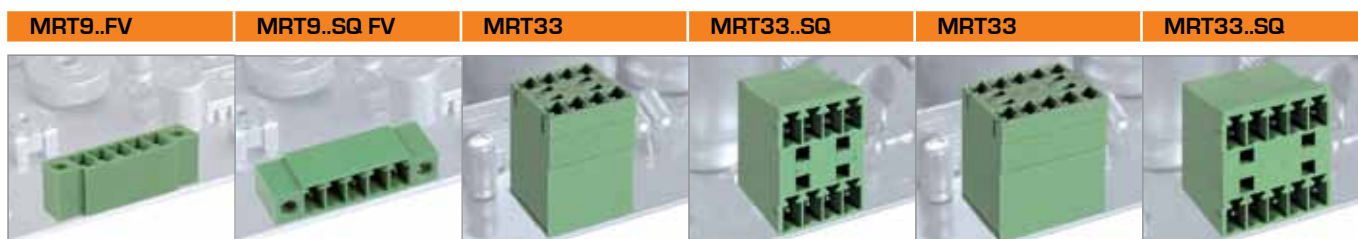

	B4		B4		B4		B4		B4		B4	
mm	7	7,62*	7	7,62*	3,81	3,81	7,62	7,62	7,62	7,62	7,62	

	I			I			I			I			I			I		
KV	4	4	4	4	4	4	2,5	2,5	2,5	2,5	2,5	2,5	4	4	4	4	4	4
—/—	III/3	III/2	II/2	III/3	III/2	II/2	III/3	III/2	II/2	III/3	III/2	II/2	III/3	III/2	II/2	III/3	III/2	II/2
V	400/500* 500/500* 630/630*			400/500* 500/500* 630/630*			200	250	500	200	250	500	500	500	630	500	500	630
A/mm ²	10/1,0; 10/1,0			10/1,0; 10/1,0			10/1,0; 10/1,0			10/1,0; 10/1,0			10/1,0; 10/1,0			10/1,0; 10/1,0		
A/AWG	8/16; 8/16			8/16; 8/16			8/16; 8/16			8/16; 8/16			8/16; 8/16			8/16; 8/16		
—	IP 00			IP 00			IP 00			IP 00			IP 00			IP 00		
KV	2,5/3*			2,5/3*			1,25			1,25			3			3		

mm	—	—	—	—	—	—
mm	0,8x0,8/1,3	0,8x0,8/1,3	0,8x0,8/1,3	0,8x0,8/1,3	0,8x0,8/1,3	0,8x0,8/1,3
—	—	—	—	—	—	—
Nm	—	—	—	—	—	—

—	PA - UL94 V0	PA - UL94 V0	PA - UL94 V0	PA - UL94 V0	PA - UL94 V0	PA - UL94 V0
—	—	—	—	—	—	—
—	CuSn 6 / Ni + Sn	CuSn 6 / Ni + Sn	CuSn 6 / Ni + Sn	CuSn 6 / Ni + Sn	CuSn 6 / Ni + Sn	CuSn 6 / Ni + Sn
—	—	—	—	—	—	—
—	—	—	—	—	—	—
—	—	—	—	—	—	—

D/
B4

Connettori maschio per C.S.
Connecteurs mâle pour C.I.

Headers for P.C.B.
Stiftleiste für Leiterplatten

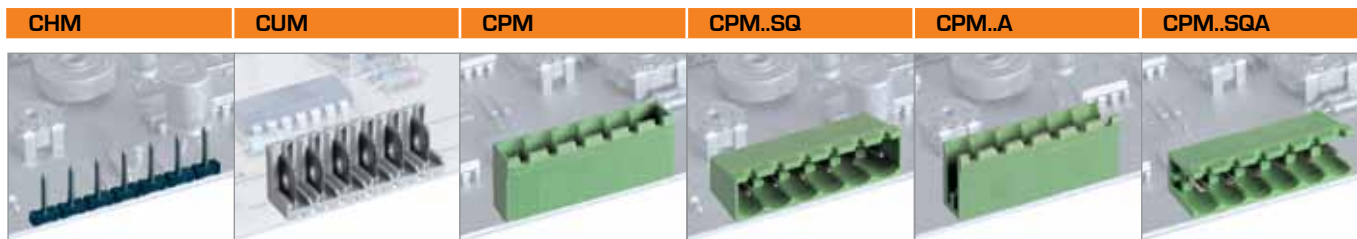

	B4		B4		B4		B4		B4		B4	
mm	5	10*	5	10*	5	5,08	5	5,08	5	5,08	5	5,08

	I			I			I			I			I			I		
KV	4	4	4	4/6*	4/6*	4/6*	4	4	4	4	4	4	4	4	4	4	4	
—/—	III/3	III/2	II/2	III/3	III/2	II/2	III/3	III/2	II/2	III/3	III/2	II/2	III/3	III/2	II/2	III/3	III/2	
V	250/630*	500/630*	630/1000*	250/500*	400/630*	630/800*	320	500	800	320	500	800	320	500	800	320	500	
A/mm ²	10/1,0; 10/1,0			18/2,5; 18/2,5			20/2,5; 20/2,5			20/2,5; 20/2,5			20/2,5; 20/2,5			20/2,5; 20/2,5		
A/AWG	10/1,5; 10/1,5			14/12; 14/12			12/12; 12/12			12/12; 12/12			12/12; 12/12			12/12; 12/12		
—	IP 00			IP 00			IP 00			IP 00			IP 00			IP 00		
KV	2/3*			2,5/3*			2,5			2,5			2,5			2,5		

mm	—	—	—	—	—	—
mm	Ø 1,3/1,5	1,0x0,7/1,3	1,0x1,0/1,6	1,0x1,0/1,6	1,0x1,0/1,6	1,0x1,0/1,6
Nm						

—	PA - UL94 V0	PC - UL94 V0	PA - UL94 V0	PA - UL94 V0	PA - UL94 V0	PA - UL94 V0
—	—	—	—	—	—	—
—	CuSn 6 / Ni + Sn	CuZn 37 / Ni + Sn	CuSn 6 / Ni + Sn	CuSn 6 / Ni + Sn	CuSn 6 / Ni + Sn	CuSn 6 / Ni + Sn
—	—	—	—	—	—	—
—	—	—	—	—	—	—
—	—	—	—	—	—	—

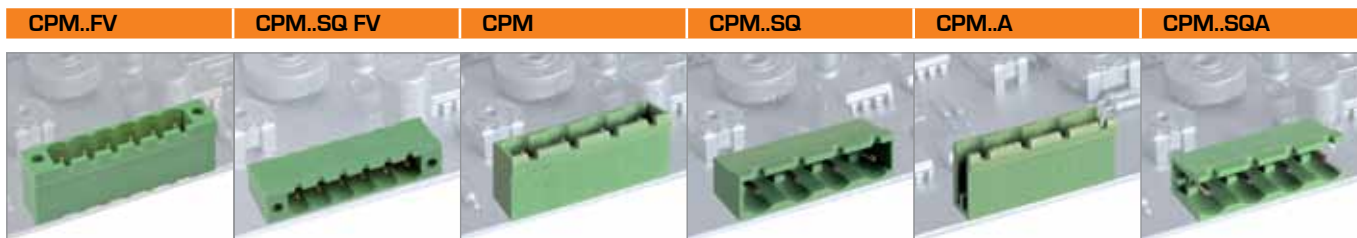

	B4		B4		B4		B4		B4		B4	
mm	5	5,08	5	5,08	7,5	7,62	7,5	7,62	7,5	7,62	7,5	7,62

	I			I			I			I			I			I		
KV	4	4	4	4	4	4	6	6	6	6	6	6	6	6	6	6	6	
—/—	III/3	III/2	II/2	III/3	III/2	II/2	III/3	III/2	II/2	III/3	III/2	II/2	III/3	III/2	II/2	III/3	III/2	
V	320	500	800	320	500	800	500	630	1000	500	630	1000	500	630	1000	500	630	
A/mm ²	20/2,5; 20/2,5			20/2,5; 20/2,5			20/2,5; 20/2,5			20/2,5; 20/2,5			20/2,5; 20/2,5			20/2,5; 20/2,5		
A/AWG	12/12; 12/12			12/12; 12/12			12/12; 12/12			12/12; 12/12			12/12; 12/12			12/12; 12/12		
—	IP 00			IP 00			IP 00			IP 00			IP 00			IP 00		
KV	2,5			2,5			3			3			3			3		

mm	—	—	—	—	—	—
mm	1,0x1,0/1,6	1,0x1,0/1,6	1,0x1,0/1,6	1,0x1,0/1,6	1,0x1,0/1,6	1,0x1,0/1,6
Nm						

—	PA - UL94 V0	PA - UL94 V0	PA - UL94 V0	PA - UL94 V0	PA - UL94 V0	PA - UL94 V0
—	—	—	—	—	—	—
—	CuSn 6 / Ni + Sn	CuSn 6 / Ni + Sn	CuSn 6 / Ni + Sn	CuSn 6 / Ni + Sn	CuSn 6 / Ni + Sn	CuSn 6 / Ni + Sn
—	—	—	—	—	—	—
—	—	—	—	—	—	—
—	—	—	—	—	—	—

D/
B4

Connettori maschio per C.S.
Connecteurs mâle pour C.I.

Headers for P.C.B.
Stiftleiste für Leiterplatten

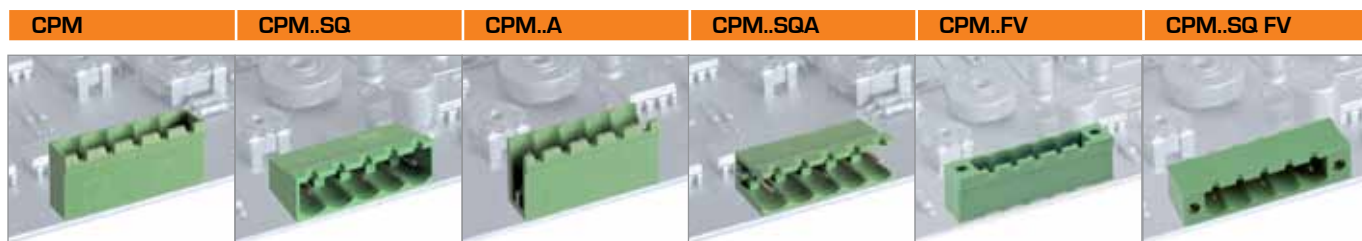

	CPM		CPM..SQ		CPM..A		CPM..SQA		CPM..FV		CPM..SQ FV	
mm	B4		B4		B4		B4		B4		B4	
	10	10,16	10	10,16	10	10,16	10	10,16	10	10,16	10	10,16

	CPM			CPM..SQ			CPM..A			CPM..SQA			CPM..FV			CPM..SQ FV		
KV	I			I			I			I			I			I		
—	6	6	6	6	6	6	6	6	6	6	6	6	6	6	6	6	6	
—/—	III/3	III/2	II/2	III/3	III/2	II/2	III/3	III/2	II/2	III/3	III/2	II/2	III/3	III/2	II/2	III/3	III/2	II/2
V	630	800	1000	630	800	1000	630	800	1000	630	800	1000	630	800	1000	630	800	1000
A/mm²	20/2,5; 20/2,5			20/2,5; 20/2,5			20/2,5; 20/2,5			20/2,5; 20/2,5			20/2,5; 20/2,5			20/2,5; 20/2,5		
A/AWG	12/12; 12/12			12/12; 12/12			12/12; 12/12			12/12; 12/12			12/12; 12/12			12/12; 12/12		
—	IP 00			IP 00			IP 00			IP 00			IP 00			IP 00		
KV	3			3			3			3			3			3		

mm	—	—	—	—	—	—
mm	1,0x1,0/1,6	1,0x1,0/1,6	1,0x1,0/1,6	1,0x1,0/1,6	1,0x1,0/1,6	1,0x1,0/1,6
—						
Nm						

—	PA - UL94 V0	PA - UL94 V0	PA - UL94 V0	PA - UL94 V0	PA - UL94 V0	PA - UL94 V0
—	—	—	—	—	—	—
—	CuSn 6 / Ni + Sn	CuSn 6 / Ni + Sn	CuSn 6 / Ni + Sn	CuSn 6 / Ni + Sn	CuSn 6 / Ni + Sn	CuSn 6 / Ni + Sn
—	—	—	—	—	—	—
—	—	—	—	—	—	—
—	—	—	—	—	—	—

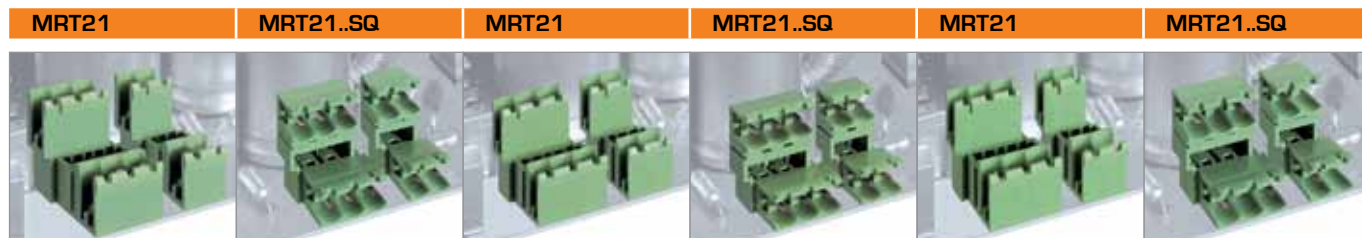

	MRT21		MRT21..SQ		MRT21		MRT21..SQ		MRT21		MRT21..SQ	
mm	B4		B4		B4		B4		B4		B4	
	5	5	5	5,08	5	5,08	10	10	10	10	10	10

	MRT21			MRT21..SQ			MRT21			MRT21..SQ			MRT21			MRT21..SQ		
KV	I			I			I			I			I			I		
—	4	4	4	4	4	4	4	4	4	6	6	6	6	6	6	6	6	
—/—	III/3	III/2	II/2	III/3	III/2	II/2	III/3	III/2	II/2	III/3	III/2	II/2	III/3	III/2	II/2	III/3	III/2	II/2
V	320	500	800	320	500	800	320	500	800	320	500	800	630	800	1000	630	800	1000
A/mm²	20/2,5; 20/2,5			20/2,5; 20/2,5			20/2,5; 20/2,5			20/2,5; 20/2,5			20/2,5; 20/2,5			20/2,5; 20/2,5		
A/AWG	12/12; 12/12			12/12; 12/12			12/12; 12/12			12/12; 12/12			12/12; 12/12			12/12; 12/12		
—	IP 00			IP 00			IP 00			IP 00			IP 00			IP 00		
KV	2,5			2,5			2,5			2,5			3			3		

mm	—	—	—	—	—	—
mm	1,0x1,0/1,6	1,0x1,0/1,6	1,0x1,0/1,6	1,0x1,0/1,6	1,0x1,0/1,6	1,0x1,0/1,6
—						
Nm						

—	PA - UL94 V0	PA - UL94 V0	PA - UL94 V0	PA - UL94 V0	PA - UL94 V0	PA - UL94 V0
—	—	—	—	—	—	—
—	CuSn 6 / Ni + Sn	CuSn 6 / Ni + Sn	CuSn 6 / Ni + Sn	CuSn 6 / Ni + Sn	CuSn 6 / Ni + Sn	CuSn 6 / Ni + Sn
—	—	—	—	—	—	—
—	—	—	—	—	—	—
—	—	—	—	—	—	—

D/
B4

Connettori maschio per C.S.
Connecteurs mâle pour C.I.

Headers for P.C.B.
Stiftleiste für Leiterplatten

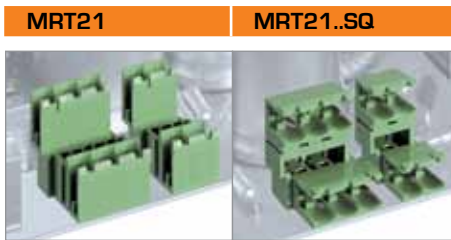

	B4	B4
mm	10,16	10,16

	I			I		
KV	6	6	6	6	6	6
—/—	III/3	III/2	II/2	III/3	III/2	II/2
V	630	800	1000	630	800	1000
A/mm ²	20/2,5; 20/2,5			20/2,5; 20/2,5		
A/AWG	12/12; 12/12			12/12; 12/12		
—	IP 00			IP 00		
KV	3			3		

mm	—	—
mm	1,0x1,0/1,6	1,0x1,0/1,6
—		
Nm		

—	PA - UL94 V0	PA - UL94 V0
—	—	—
—	CuSn 6 / Ni + Sn	CuSn 6 / Ni + Sn
—	—	—
—	—	—
—	—	—

D/
B4

Per gli elementi di connessione in questo catalogo, con riferimento al tipo di costruzione e di impiego, valgono principalmente le seguenti normative.

Pour les composants de connectique de ce catalogue, suivant le type de construction ou d'utilisation, sont applicables principalement les normes suivantes.

For the connection elements in this catalogue, depending on the type of construction and use, are mainly valid the following standards.

Für die in diesem Katalog enthaltenen elektrischen Verbindungselemente gelten je nach Bauart und spezifischer Anwendung im wesentlichen folgende Normen.

Norme Normes		Standard Normen			
IEC	EN	CEI	UL	CSA	ISO
IEC 60068 IEC 60112	EN 60529 EN 60695-2-1	CEI 28-6 CEI 50...	UL 1059 UL 486A		
IEC 60228 IEC 60529	EN 60695-2-2 EN 60947-1	CEI 61210 CEI 70-1	UL 486B UL 486C		
IEC 60664-1 IEC 60695-2-1	EN 60947-7-1 EN 61984	CEI EN 60664-1 CEI EN 60947-1	UL 486D UL 486E		
IEC 60695-2-2 IEC 60947-1	EN 60998-1 EN 60998-2-1	CEI EN 60947-7-1 CEI EN 61984			
IEC 60947-7-1 IEC 61984	EN 60998-2-2 EN 60998-2-3	CEI EN 60998-1 CEI EN 60998-2-1			
IEC 60998-1 IEC 60998-2-1	EN 60998-2-4 EN 60998-2-5	CEI EN 60998-2-2 CEI EN 60998-2-3		C 22.2 n° 158	
IEC 60998-2-2 IEC 60998-2-3	EN 60999	CEI EN 60998-2-4 CEI EN 60998-2-5			
IEC 60998-2-4 IEC 60998-2-5		CEI EN 60999			ISO 1456
IEC 60999 IEC 61210					ISO 2081 ISO 2093

Lo schema seguente mostra, per le principali caratteristiche, la correlazione tra le tabelle delle pagine seguenti e le relative norme di riferimento.

Le schéma suivant montre, pour les plus importantes caractéristiques d'utilisation, la corrélation entre les divers tableaux explicatifs reportés dans les pages suivantes et les normes auxquelles il est fait référence.

The following tables show, for the main characteristics, the correlation between the tables of the following pages and the relevant standards.

Normen und deren Inhaltsschwerpunkte tabellarisch geordnet. Bitte beachten Sie die nachfolgenden Einzeltabellen.

Descrizione Description	Description Beschreibung	Tabella Tableaux	Tables Tabellen	Norme Normes	Standard Normen
Materiali termoplastici Matériaux thermoplastiques	Thermoplastic materials Thermoplastische Materialien		TAB 0		—
Categorie di sovratensione Catégorie de surtension	Overvoltage categories Überspannungskategorie		TAB 1	IEC 60664-1 IEC/EN 60947-1	
Grado di inquinamento Degré de pollution	Pollution degree Verschmutzungsgrad		TAB 2	CEI 28-6 IEC 60664-1 IEC/EN 60947-1	
Materiale isolante Matériaux isolants	Insulating materials Isolierstoffe		TAB 3	CEI 28-6 IEC 60664-1 IEC/EN 60947-1	
Tensione nominale di tenuta ad impulso delle apparecchiature	Rated impulse voltage of equipment		TAB 4	CEI 28-6 IEC 60664-1 IEC/EN 60947-1	
Tension de tenue aux chocs électriques impulsifs pour appareillage	Bemessungs-Stoßspannung der Geräte		TAB 4	CEI 28-6 IEC 60664-1 IEC/EN 60947-1	
Valori minimi per le distanze in aria Distances minimales d'isolement dans l'air	Minimum clearances in air Mindestluftstrecken		TAB 5	CEI 28-6 IEC 60664-1 IEC/EN 60947-1	
Tensioni impulsive/altitudine Tensions impulsives/altitude	Rated impulse voltage/altitude Bemessungs-Stoßspannung/Höhe		TAB 6	CEI 28-6 IEC 60664-1 IEC/EN 60947-1	
Tensioni nominali Tension nominale	Rated voltage Bemessungsspannung		TAB 7a	CEI 28-6 IEC 60664-1 IEC/EN 60947-1	
Tensioni nominali Tension nominale	Rated voltage Bemessungsspannung		TAB 7b	CEI 28-6 IEC 60664-1 IEC/EN 60947-1	
Distanze superficiali Distances de surface	Creepage distances Kriechstrecken		TAB 8	CEI 28-6 IEC 60664-1 IEC/EN 60947-1	
Cavi (mm²/A) Conducteur (mm ² /A)	Conductors (mm²/A) Leiter (mm ² /A)		TAB 9a	IEC/EN/CEI EN 60947-1 / 60947-7-1 60998-1 / 60998-2(1...5)	
Cavi (mm²/A) Conducteur (mm ² /A)	Conductors (mm²/A) Leiter (mm ² /A)		TAB 9b	IEC/EN/CEI EN 60947-1 / 60947-7-1 60998-1 / 60998-2(1...5)	
Viti / Coppia di serraggio Vis / Couple de serrage	Screws / Torque Schraube / Anzugsmoment		TAB 10a	IEC/EN/CEI EN 60947-1 / 60947-7-1 60998-1 / 60998-2(1...5)	
Cavi - trazione Conducteur - traction	Conductors - tensile Leiter - Zugfestigkeit		TAB 10b	IEC/EN/CEI EN 60947-1 / 60947-7-1 60998-1 / 60998-2(1...5)	
Cavi - rotazione Conducteur - rotation	Conductors - rotation Leiter - Verdrehfestigkeit		TAB 10c	IEC/EN/CEI EN 60947-1 / 60947-7-1 60998-1 / 60998-2(1...5)	
Sezione / Corrente (mm²/A) Section / Courant (mm ² /A)	Section / Current (mm²/A) Querschnitt / Bemessungsstrom (mm ² /A)		TAB 11a	IEC/EN/CEI EN 60947-1 / 60947-7-1 60998-1 / 60998-2(1...5)	
Sezione / Corrente (AWG/A) Section / Courant (AWG/A)	Section / Current (AWG/A) Querschnitt / Bemessungsstrom (AWG/A)		TAB 11b	UL 486E	

I corpi isolanti dei prodotti Stelvio sono realizzati con materiale termoplastico che garantisce un elevato contenuto tecnologico rispondente alle richieste normative sia delle apparecchiature elettriche ed elettroniche sia delle morsettiere. La tabella mostra alcuni requisiti utili per l'applicazione.

Les corps isolants des produits Stelvio sont réalisés avec un matériau thermoplastique qui garantit un niveau technologique élevé répondant aux critères normatifs que ce soit pour l'appareillage électrique et électronique ou pour les blocs de jonction. Le tableau indique certaines données requises utiles pour l'application.

The insulating bodies of Stelvio products are made of thermoplastic material that guarantees a high technological level complying with the international standard of both electrical and electronic equipments and terminal blocks. The table below shows some useful data for the application.

Die Isoliergehäuse der Stelvio-Produkte bestehen, entsprechend der internationalen Normen für elektrische und elektronische Geräte und Klemmleisten, aus hochwertigen thermoplastischen Materialien. Die u. a. Tabelle beinhaltet für Ihre Anwendung wichtige allgemeine technische Daten.

TAB 0

Materiali termoplastici	Thermoplastic materials	Matériaux thermoplastiques	Thermoplastische Materialien				
Descrizione Description Description Beschreibung		UM	PA - UL94 VO	PA G - UL94 VO	PA 4 - UL94 VO	PC - UL94 VO	PPOM - UL94 V1
Indice termico relativo RTI (el - mc - mcw) Relative Thermal Index (el - mc - mcw) Indice Thermique Relatif RTI (el - mc - mcw) Relativer Temperaturindex RTI (el - mc - mcw)	UL 746 B	°C	140 - 95 - 110	140 - 120 - 130	140 - 110 - 120	130 - 125 - 125	110 - 105 - 110
Temperatura di utilizzo Working Temperature Température d'utilisation Umgebungstemperaturbereich		°C	-30 ÷ 120	-30 ÷ 120	-30 ÷ 120	-30 ÷ 120	-30 ÷ 120
Resistenza alle correnti superficiali (CTI) Comparative Tracking Index (CTI) Indice de cheminement (CTI) Kriechstromfestigkeit (CTI)	IEC 60112	V	≥ 600	400 ÷ 600	175 ÷ 400	175 ÷ 250	175 ÷ 250
Prove relative ai rischi di incendio - Fiamme di prova - 50W Fire hazard testing - - Test flames Essais relatifs aux risques d'incendie - Flammes d'essai Prüfungen zur Beurteilung der Brandgefahr - Prüfflammen	IEC 60695-11-10	mm - ID	0,41 - VO	0,7 - VO	0,35 - VO	1,5 - VO	1,5 - V1
Prove relative ai rischi di incendio - Metodo di prova della fiamma con ago - 10 sec Fire hazard testing - Needle-flame test method Essais relatifs aux risques d'incendie - Méthode d'essai au brûle-aiguille d'incendie Prüfungen zur Beurteilung der Brandgefahr - Nadelflamme Prüfung	IEC 60695-11-5	mm - °C	1,0 - 850	1,0 - 850	1,0 - 850	1,0 - 850	1,0 - 850
Indice di infiammabilità al filo incandescente Glow-Wire Flammability Index (GWFI) Indice d'Inflamabilité au fil incandescent Glühdrahtprüfung nach GWFI (850 °C)	IEC 60695-2-12	mm - °C	0,7 - 960	0,7 - 960	1,0 - 960	1,0 - 960	1,0 - 960
Temperatura di accensione al filo incandescente Glow-wire ignition temperature (GWIT) Température d'Allumage au fil incandescent Glühdrahtprüfung nach GWIT (750 °C)	IEC 60695-2-13	mm - °C	0,7 - 960	0,7 - 850	1,0 - 960	1,0 - 960	1,0 - 800
Prove relative ai rischi di incendio - Calore anormale - Prova di pressione con la sfera Fire hazard testing - Abnormal heat - Ball pressure test Essais relatifs aux risques du feu - Chaleurs anormales - Essai à la bille Prüfungen zur Beurteilung der Brandgefahr - Unübliche Wärme - Kugeldruckprüfung	IEC 60695-10-2	mm - °C	1,0 - 165	1,0 - 165	1,0 - 165	1,0 - 125	1,0 - 125

Prescrizioni di isolamento

Le prescrizioni di isolamento hanno lo scopo di determinare le distanze minime in aria e superficie dipendenti dalla resistenza di isolamento nelle sollecitazioni effettive. Le distanze in aria sono determinate dalle sovratensioni previste (TAB1). Le distanze superficiali sono determinate dalle tensioni nominali e dalle condizioni ambientali dirette (TAB2-TAB3). Salvo diversa indicazione nella descrizione specifica dei prodotti la tensione nominale è calcolata con riferimento alla categoria di sovratensione (III) e grado di inquinamento (3).

Prescriptions d'isolement

Les prescriptions d'isolement ont pour objet de déterminer les distances minimum dans l'air et en surface en fonction de la résistance d'isolement pour les sollicitations effectives. Les distances dans l'air sont déterminées suivant les surtensions prévues (TAB1), les distances en surface sont déterminées suivant les tensions nominales et les conditions d'environnement directes (TAB2-TAB3). Sauf indication contraire dans la description spécifique des produits la tension nominale est calculée en se référant à la catégorie de surtension (III) et au degré de pollution (3).

Insulation requirements

Insulation specifications have the purpose to determine the smallest clearances and creepage distances that depend on insulation resistance in real use condition. Air distances are determined by the expected overvoltages (TAB1). Surface distances are determined by rated voltage and by direct environment conditions (TAB2-TAB3). Except for different directions in product specific description, rated voltage is calculated with reference to overvoltage category (III) and pollution degree (3).

Anforderungen bezüglich Isolierung

Isolationsspezifikationen haben den Zweck die min. Luft- und Kriechstrecken zu bestimmen, die vom Isolationswiderstand der jeweils konkreten Einsatzbedingungen abhängen. Luftstrecken werden durch die zu erwartende Überspannung festgelegt (TAB1). Kriechstrecken werden durch die Nennspannung und durch die vorhandenen Umgebungsbedingungen bestimmt (TAB2-TAB3). Wenn nicht anders in der Produktspezifikation angegeben, wird die Nennspannung in Bezug auf die Überspannungskategorie (III) und den Verschmutzungsgrad (3) berechnet.

TAB 1

Categorie di sovratensione	Overvoltage categories	Catégorie de surtension	Überspannungskategorie
I	II	III	IV
Componenti destinati esclusivamente ad applicazioni in apparecchiature o parti di impianti, in cui si esclude l'insorgenza di sovratensioni o si è in presenza di particolari protezioni contro le medesime.	Componenti destinati ad applicazioni in impianti o loro parti, in cui non si devono considerare sovratensioni derivate da scariche atmosferiche ma provocate da manovre di commutazione.	Componenti destinati ad applicazioni in impianti o loro parti, in cui non si devono considerare sovratensioni derivate da scariche atmosferiche ma provocate da manovre di commutazione e si pongono particolari requisiti relativamente alla sicurezza e disponibilità del componente o da reti da esso dipendenti. Le sovratensioni prodotte dai componenti stessi non devono superare i valori della categoria di sovratensione II.	Componenti destinati ad applicazioni in impianti o loro parti, in cui si devono considerare sovratensioni derivate da scariche atmosferiche. Le sovratensioni prodotte dai componenti stessi non devono superare i valori della categoria di sovratensione II.
Components suitable for equipments or plant parts only, where overvoltages are excluded or special protections against that are applied.	Components suitable for plants or their parts, where overvoltages due to commutation control and not caused by atmospheric discharges shall be considered.	Components suitable for plants or their parts, where overvoltages due to commutation control and not caused by atmospheric discharges shall be considered, where special safety requirements of component or of component depending nets are also involved. Overvoltages caused by components have not to exceed overvoltage category value II.	Components suitable for plants or their parts, where overvoltages due to atmospheric discharges shall be considered. Overvoltages caused by components have not to exceed overvoltage category value II.
Composants destinés exclusivement aux applications dans les appareillages ou dans une partie des installations, pour lesquelles il est exclu l'emergence de surtensions sauf si l'on est en présence de protections particulières pour ces dernières.	Composants destinés aux applications dans les installations en totalité ou partiellement pour lesquelles nous ne devons pas prendre en considération les surtensions provenant de décharges atmosphériques, mais celles provoquées par des manœuvres de commutation.	Composants destinés aux applications dans les installations en totalité ou partiellement, pour lesquelles nous ne devons pas prendre en considération les surtensions provenant de décharges atmosphériques, mais celles provoquées par des manœuvres de commutation et où doivent être pris en compte des conditions particulières relatives à la sécurité et la disponibilité du composant ou des réseaux dont ils dépendent. Les surtensions produites par les composants eux mêmes ne doivent pas dépasser les valeurs de la catégorie de surtension II.	Composants destinés aux applications dans les installations en totalité ou partiellement, pour lesquelles nous devons prendre en considération les surtensions provenant de décharges atmosphériques. Les surtensions produites par les composants eux mêmes ne doivent pas dépasser les valeurs de la catégorie de surtension II.
Geräte für Anlagen oder Gebäudeinstallationen, bei denen Überspannungen ausgeschlossen oder spezielle Schutzmaßnahmen gegen diese getroffen wurden.	Geräte für Gebäudeinstallationen oder deren Teile, bei denen Überspannungen aufgrund von Kommutierungsvorgängen und nicht durch atmosphärische Störungen (Blitzschlag) hervorgerufen werden.	Geräte für Gebäudeinstallationen oder deren Teile, bei denen Überspannungen aufgrund von Kommutierungsvorgängen und nicht durch atmosphärische Störungen (Blitzschlag) hervorgerufen werden und bei denen erhöhte Sicherheitsanforderungen an Geräte oder Geräte abhängige (Versorgungs-) Netze gestellt werden. Durch Geräte verursachte Überspannungen dürfen nicht die Überspannungskategorie II übersteigen.	Geräte für Gebäudeinstallationen oder deren Teile, bei denen Überspannungen aufgrund von atmosphärischen Störungen (Blitzschlag) berücksichtigt werden. Durch Geräte verursachte Überspannungen dürfen nicht die Überspannungskategorie II übersteigen.

TAB 2

Grado di inquinamento	Pollution degree	Degré de pollution	Verschmutzungsgrad
I	II	III	IV
Non esiste inquinamento o si produce soltanto un inquinamento secco, non conduttore. L'inquinamento non ha influenza.	Si produce soltanto un inquinamento non conduttore. Ci si deve tuttavia aspettare occasionalmente una conduttività temporanea provocata dalla condensazione.	Si produce un inquinamento conduttore o un inquinamento secco, non conduttore, che diviene conduttore a seguito della condensazione che può prodursi.	L'inquinamento produce una conduttività persistente causata dalla polvere conduttrice, dalla pioggia o dalla neve.
No pollution or only dry, non-conductive pollution occurs. The pollution has no influence.	Only non-conductive pollution occurs except that occasionally a temporary conductivity caused by condensation is to be expected.	Conductive pollution occurs or dry non-conductive pollution occurs which becomes conductive due to condensation which is to be expected.	The pollution generates persistent conductivity caused by conductive dust or by rain or snow.
Il n'existe aucun degré de pollution ou seulement une pollution sèche non conductive.	Normalement, il n'y a présence que d'une pollution non conductive, toutefois occasionnellement, on peut s'attendre à une conductibilité temporaire causée par de la condensation.	Il existe une pollution conductive, ou une pollution sèche non conductive qui le devient suite à de la condensation.	La pollution provoque une conductibilité persistante par exemple, à cause de la poussière conductive, ou de la pluie, ou de la neige.
Es tritt keine oder nur trockene, nicht leitfähige Verschmutzung auf. Die Verschmutzung hat keinen Einfluss.	Es tritt nur nicht leitfähige Verschmutzung auf. Gelegentlich muss mit vorübergehender Leitfähigkeit durch Kondensation gerechnet werden.	Es tritt leitfähige Verschmutzung auf oder trockene, nicht leitfähige Verschmutzung, die leitfähig wird, da Kondensation zu erwarten ist.	Die Verschmutzung führt zu einer beständigen Leitfähigkeit, hervorgerufen durch leitfähigen Staub, Regen oder Schnee.

TAB 3

Materiale isolante	Insulating materials	Matériaux isolants	Isoliermaterial	
I	II	IIIa	IIIb	
CTI	600 ≤ CTI	400 ≤ CTI < 600	175 ≤ CTI < 400	100 ≤ CTI < 175

TAB 4

Tensione nominale di tenuta ad impulso delle apparecchiature
Rated impulse voltage of equipment

Tension de tenue aux chocs électriques impulsifs pour appareillage
Bemessungs-Stoßspannung für Betriebsmittel

Tensione nominale di installazione (V) Nominal voltage of the installation (V) Tension réseau assignée (V) Nennspannung des Stromversorgungssystems(V)		Tensione di tenuta ad impulso (kV) richiesta per Required impulse withstand voltage (kV) for Tension de tenue aux chocs en (kV) pour Bemessungs-Stoßspannung (kV) für			
Sistemi trifase Three-phase systems Systèmes triphasés Drei-Phasen Systeme	Sistemi monofase con punto centrale Single-phase system with middle point Systèmes triphasés avec point central Ein-Phasen-Systeme mit Mittelpunkt	Apparecchiatura all'origine dell'impianto Equipment at the origin of the installation Matériels sur la ligne d'alimentation de l'installation Betriebsmittel an der Einspeisung der Installation	Apparecchiatura parte dell'impianto fisso Equipment which is part of the fixed installation Matériels partie intégrante de l'installation fixe Betriebsmittel als Teil der festen Installation	Apparecchiatura da collegare all'impianto fisso Equipment to be connected to the fixed installation Matériels à raccorder à l'installation fixe Betriebsmittel zum Anschluss an die feste Installation	Apparecchiatura con protezione speciale Specially protected equipment Matériels bénéficiant de mesures de protection particulières Besonders geschützte Betriebsmittel
		Categoria di tenuta all'impulso Catégories de surtension		Impulse withstand category Überspannungskategorie	
		IV	III	II	I
	120 - 240	4	2,5	1,5	0,8
230/400 277/480		6	4	2,5	1,5
400/690		8	6	4	2,5
1000		12	8	6	4

TAB 5

Valori minimi per le distanze in aria

Minimum clearances in air

Distances minimales d'isolement dans l'air

Mindestluftstrecken

Tensione di tenuta ad impulso richiesta Required impulse withstand voltage Tension de tenue aux impulsions requise Erforderliche Stoß-Spannungsfestigkeit	Minime distanze di isolamento in aria (mm) Distances min. d'isolement dans l'air (mm)				Minimum clearances in air (mm) Mindestluftstrecken (mm)			
	Caso A - Case A Cas A - Fall A				Caso B - Caso B Cas B - Fall B			
	Campo non uniforme - Inhomogeneous field Champ non homogène - Inhomogenes Feld				Campo uniforme - Homogeneous field Champ homogène - Homogenes Feld			
	Grado di inquinamento - Pollution degree Degré de pollution - Verschmutzungsgrad				Grado di inquinamento - Pollution degree Degré de pollution - Verschmutzungsgrad			
kV	1	2	3	4	1	2	3	4
0,33	0,01				0,01			
0,40	0,02				0,02			
0,50	0,04				0,04			
0,60	0,06	0,2	0,8	1,6	0,06	0,2	0,8	1,6
0,80	0,1				0,1			
1,0	0,15				0,15			
1,20	0,25	0,25			0,2			
1,50	0,5	0,5			0,3	0,3		
2,0	1,0	1,0	1		0,45	0,45		
2,5	1,5	1,5	1,5		0,6	0,6		
3,0	2	2	2	2	0,8	0,8		
4,0	3	3	3	3	1,2	1,2	1,2	
5,0	4	4	4	4	1,5	1,5	1,5	
6,0	5,5	5,5	5,5	5,5	2	2	2	2
8,0	8	8	8	8	3	3	3	3
10,0	11	11	11	11	3,5	3,5	3,5	3,5
12	14	14	14	14	4,5	4,5	4,5	4,5

TAB 6

Tensioni impulsive / altitudine

Rated impulse voltage / altitude

Tension impulsives / altitudes

Bemessungs-Stoßspannung / Höhe über

Tensione di tenuta ad impulso Rated impulse withstand voltage Tension nominale de tenue aux impulsions Bemessungs-Stoßspannung	Tensioni di prova e altitudini corrispondenti Tensions d'essais et altitudes correspondantes					Test voltages and corresponding altitudes Testspannungen bei entsprechender Höhe über				
	U _{1,2/50}									
	kV	0 m	200 m	500 m	1000 m	2000 m				
0,33	0,35	0,35	0,35	0,34	0,33					
0,5	0,55	0,54	0,53	0,52	0,5					
0,8	0,91	0,9	0,9	0,85	0,8					
1,5	1,75	1,7	1,7	1,6	1,5					
2,5	2,95	2,8	2,8	2,7	2,5					
4,0	4,8	4,8	4,7	4,4	4,0					
6,0	7,3	7,2	7,0	6,7	6,0					
8,0	9,8	9,6	9,3	9,0	8,0					
12,0	14,8	14,5	14,0	13,3	12,0					

TAB 7a

Tensioni nominali Tension nominale		Rated voltage Bemessungsspannung	
Reti monofasi a 3 o 2 fili c.a. o c.c. Single-phase 3 or 2 a.c. or d.c. systems Réseaux monophasés 3 fils ou 2 fils en c.a. ou c.c. Einphasige 3 oder 2 Leiter-Wechsel-oder Gleichspannungsnetze			
Tensione nominale della rete di alimentazione	Per isolamento tra fasi For insulation line-to-line Pour isolement entre phases Für Isolierung Leiter-Leiter	Per isolamento fase-terra For insulation line-to-earth Pour isolement phase-terre Für Isolierung Leiter-Erde	
Nominal voltage of the supply system	Tutte le reti	Reti a 3 fili con punto centrale a terra	
Tension nominale du réseau d'alimentation	All systems	3 wire systems mid-point earthed	
Nennspannung des Stromversorgungssystems	Tous les réseaux	Réseaux 3 conducteurs avec point central à la terre	
	Alle Systeme	3-Leitersysteme Mittelpunkt geerdet	
V	V	V	V
12,5	12,5	—	—
24/25	25	—	—
30	32	—	—
42/48/50	50	—	—
60	63	—	—
30-60	63	32	—
100	100	—	—
110/120	125	—	—
150	160	—	—
200	200	—	—
100-200	200	100	—
220	250	—	—
110-220/120-240	250	125	—
300	320	—	—
220-440	500	250	—
600	630	—	—
480-960	1000	500	—
1000	1000	—	—

TAB 7b

Tensioni nominali Tension nominale		Rated voltage Bemessungsspannung	
Reti c.a. trifase a 4 o a 3 fili Three-phase 4 or 3 wire a.c. systems Réseaux triphasés, 4 ou 3 fils en courant alternatif Dreiphasige 4 oder 3 Leiter-Wechselspannungssysteme			
Tensione nominale della rete di alimentazione	Per isolamento tra fasi For insulation line-to-line Pour isolement entre phases Für Isolierung Leiter-Leiter	Per isolamento fase-terra For insulation line-to-earth Pour isolement phase-terre Für Isolierung Leiter-Erde	
Nominal voltage of the supply system	Tutte le reti	Reti trifasi a 4 fili con neutro a terra	Reti trifasi a 3 fili non collegati a terra o una fase collegata a terra
Tension nominale du réseau d'alimentation	All systems	Three-phase 4 wire systems neutral-earthed	Three-phase 3 wire systems unearthed or corner-earthed
Nennspannung des Stromversorgungssystems	Tous les réseaux	Réseaux triphasés 4 conducteurs avec conducteur neutre à la terre	Réseau triphasé 3 conducteurs sans terre ou phase à la terre
	Alle Systeme	Dreiphasige 4 Leitersysteme mit geerdetem Neutralleiter	Dreiphasige 3 Leitersysteme ungeerdet oder Leiter geerdet
V	V	V	V
60	63	32	63
110/120/127	125	80	125
150	160	—	160
200	200	—	200
208	200	125	200
220/230/240	250	160	250
300	320	—	320
380/400/415	400	250	400
440	500	250	500
480/500	500	320	500
575	630	400	630
600	630	—	630
660/690	630	400	630
720/830	800	500	800
960	1000	630	1000
1000	1000	—	1000

TAB 8

Distanze superficiali Creepage distance Lignes de fuite Kriechstrecken

Tensione in valore efficace Voltage r.m.s. Tension mesure de la valeur efficace Spannung Effektivwert	Distanze superficiali minime per le apparecchiature sottoposte a sollecitazioni di lunga durata (mm) Minimum creepage distances for equipment subject to long-term stresses (mm) Lignes de fuite minimales pour matériels soumis à des contraintes de tension de longue durée (mm) Mindestkriechstrecken für Betriebsmittel mit langzeitiger Spannungsbeanspruchung (mm)																	
	Circuiti stampati Printed wiring terminal Circuits imprimés Gedruckte Schaltungen			Altre apparecchiature Autres appareillages			Other equipments Weitere Betriebsmittel			Pollution degree			Degré de pollution			Verschmutzungsgrad		
	Grado di inquinamento		1		2		1		2		3		4		Gruppen			
	Gruppo materiale		(1)		(2)		(1)		(II)		(IIIa IIIb)		(I)		(II)		(IIIa (3) IIIb (3))	
V	(1)	(2)	(1)	(II)	(IIIa IIIb)	(I)	(II)	(IIIa IIIb)	(I)	(II)	(IIIa IIIb)	(I)	(II)	(IIIa (3) IIIb (3))	(I)	(II)	(IIIa (3) IIIb (3))	
10	0,025	0,040	0,08	0,40	0,40	0,40	1,0	1,0	1,0	1,0	1,0	1,6	1,6	1,6	1,6	1,6	1,6	
12,5	0,025	0,040	0,09	0,42	0,42	0,42	1,05	1,05	1,05	1,05	1,05	1,6	1,6	1,6	1,6	1,6	1,6	
16	0,025	0,040	0,10	0,45	0,45	0,45	1,1	1,1	1,1	1,1	1,1	1,6	1,6	1,6	1,6	1,6	1,6	
20	0,025	0,040	0,11	0,48	0,48	0,48	1,2	1,2	1,2	1,2	1,2	1,6	1,6	1,6	1,6	1,6	1,6	
25	0,025	0,040	0,125	0,50	0,50	0,50	1,25	1,25	1,25	1,25	1,25	1,7	1,7	1,7	1,7	1,7	1,7	
32	0,025	0,040	0,14	0,53	0,53	0,53	1,3	1,3	1,3	1,3	1,3	1,8	1,8	1,8	1,8	1,8	1,8	
40	0,025	0,040	0,16	0,56	0,80	1,1	1,4	1,6	1,8	1,9	2,4	2,4	2,4	3,8	3,8	3,8	3,8	
50	0,025	0,040	0,18	0,60	0,85	1,2	1,5	1,7	1,9	2,0	2,5	2,5	2,5	3,2	3,2	3,2	3,2	
63	0,040	0,063	0,20	0,63	0,90	1,25	1,6	1,8	2,0	2,1	2,6	2,6	2,6	3,4	3,4	3,4	3,4	
80	0,063	0,10	0,22	0,67	0,95	1,3	1,7	1,9	2,1	2,2	2,8	2,8	2,8	3,6	3,6	3,6	3,6	
100	0,10	0,16	0,25	0,71	1,0	1,4	1,8	2,0	2,2	2,4	3,0	3,0	3,0	3,8	3,8	3,8	3,8	
125	0,16	0,25	0,28	0,75	1,05	1,5	1,9	2,1	2,4	2,5	3,2	3,2	3,2	4,0	4,0	4,0	4,0	
160	0,25	0,40	0,32	0,8	1,1	1,6	2,0	2,2	2,5	3,2	4,0	4,0	4,0	5,0	5,0	5,0	5,0	
200	0,40	0,63	0,42	1,0	1,4	2,0	2,5	2,8	3,2	4,0	5,0	5,0	5,0	6,3	6,3	6,3	6,3	
250	0,56	1,0	0,56	1,25	1,8	2,5	3,2	3,6	4,0	5,0	6,3	6,3	6,3	8,0	8,0	8,0	8,0	
320	0,75	1,6	0,75	1,6	2,2	3,2	4,0	4,5	5,0	6,3	8,0	8,0	8,0	10,0	10,0	10,0	10,0	
400	1,0	2,0	1,0	2,0	2,8	4,0	5,0	5,6	6,3	8,0	10,0	10,0	10,0	12,5	12,5	12,5	12,5	
500	1,3	2,5	1,3	2,5	3,6	5,0	6,3	7,1	8,0	10,0	12,5	12,5	12,5	16,0	16,0	16,0	16,0	
630	1,8	3,2	1,8	3,2	4,5	6,3	8,0	9,0	10,0	12,5	16,0	16,0	16,0	20,0	20,0	20,0	20,0	
800	2,4	4,0	2,4	4,0	5,6	8,0	10,0	11,0	12,5 (3)	16,0	20,0	20,0	20,0	25,0	25,0	25,0	25,0	
1000	3,2	5,0	3,2	5,0	7,1	10,0	12,5	14,0	16,0 (3)	20,0	25,0	25,0	25,0	32,0	32,0	32,0	32,0	

(1) Gruppi materiale I, II, IIIa, IIIb
Matériau isolant I, II, IIIa, IIIb

(2) Gruppi materiale I, II, IIIa
Matériau isolant I, II, IIIa

(3) Materiali isolanti non raccomandati per queste categorie
Matériau isolant non recommandé pour ces catégories

Material group I, II, IIIa, IIIb
Isolierstoffgruppe I, II, IIIa, IIIb

Material group I, II, IIIa
Isolierstoffgruppe I, II, IIIa

Insulating material not recommended for these categories
Für diesen Verschmutzungsgrad nicht empfohlen.

La sezione nominale dei morsetti componibili deve essere indicata dal costruttore secondo le norme di riferimento. Si tratta della sezione del conduttore (generalmente massima) che può essere collegata al punto di serraggio e alla quale si riferiscono le prove elettriche, meccaniche e termiche menzionate nella normativa. Le tabelle seguenti mostrano i valori preferenziali utilizzati nella progettazione dei prodotti.

La section nominale des blocs de jonction à assembler doit être indiquée par le constructeur suivant la norme de référence. Il s'agit de la section du conducteur (généralement maximum) qui peut être connecté au point de serrage et pour laquelle se rapportent les essais électriques, mécaniques et thermiques mentionnés dans la norme. Les tableaux suivants indiquent les valeurs préférentielles utilisées dans la conception des produits.

Manufacturer has to specify nominal section of modular terminal blocks according to Standards in force. That is conductor section (usually the biggest one) that can be connected with clamping point. Electric, mechanic and thermic tests stated in the Standards refer to that. Following tables show selected values used in product planning.

Der Hersteller muss den Nenn-Querschnitt der Klemmen gemäß der geltenden Norm spezifizieren. Dies ist der Leiterquerschnitt (gewöhnlich der größte), der geklemmt werden kann. In der Norm vorgegebene elektrische, mechanische und thermische Tests beziehen sich darauf. Die nachfolgenden Tabellen zeigen die zu berücksichtigenden Werte.

TAB 9a

Cavi (mm²) Conducteurs (mm²)				Conductors (mm²) Leiter (mm²)			
Sezione Section Section Querschnitt	Diametro cavi max. Diamètre conducteur max. Leiter Durchmesser max.			Calibro accessibilità Gauges Calibres Eichmaß	Sezione Section Section Querschnitt		
mm²	Solido Solide Eindrähtig	Cordato Stranded Câblé Mehrdrähtig	Flessibile Flexible Souple Feindrähtig	Solido Solide Eindrähtig	Cordato Stranded Câblé Mehrdrähtig	Flessibile Flexible Souple Feindrähtig	AWG
0,2	0,51	0,53	0,61	0,7	0,7	0,7	24
0,34	0,63	0,66	0,8	0,9	0,9	0,9	22
0,5	0,9	1,1	1,1	1	1,2	1,2	20
0,75	1	1,2	1,3	1,1	1,3	1,4	18
1	1,2	1,4	1,5	1,3	1,5	1,6	—
1,5	1,5	1,7	1,8	1,6	1,8	1,9	16
2,5	1,9	2,2	2,3	2	2,3	2,4	14
4	2,4	2,7	2,9	2,5	2,8	3	12
6	2,9	3,3	3,9	3	3,4	4	10
10	3,7	4,2	5,1	3,8	4,3	5,2	8
16	4,6	5,3	6,3	4,7	5,4	6,4	6
25	—	6,6	7,8	—	6,7	7,9	4
35	—	7,9	9	—	8	9,3	2

TAB 9b

Cavi (AWG) Conducteurs (AWG)				Conductors (AWG) Leiter (AWG)			
Sezione Section Section Querschnitt	Diametro cavi max. Diamètre conducteur max. Leiter Durchmesser max.			Sezione Section Section Querschnitt			mm2
AWG	Solido Solide Eindrähtig	Cordato Stranded Câblé Mehrdrähtig	Flessibile Flexible Souple Feindrähtig	AWG	Solido Solide Eindrähtig	Cordato Stranded Câblé Mehrdrähtig	Flessibile Flexible Souple Feindrähtig
30	0,25	0,29	0,30	30	0,25	0,29	0,30
28	0,32	0,36	0,38	28	0,32	0,36	0,38
26	0,40	0,46	0,48	26	0,40	0,46	0,48
24	0,54	0,61	0,64	24	0,54	0,61	0,64
22	0,68	0,71	0,80	22	0,68	0,71	0,80
20	0,85	0,97	1,02	20	0,85	0,97	1,02
18	1,07	1,23	1,28	18	1,07	1,23	1,28
16	1,35	1,55	1,60	16	1,35	1,55	1,60
14	1,71	1,95	2,08	14	1,71	1,95	2,08
12	2,15	2,45	2,70	12	2,15	2,45	2,70
10	2,72	3,09	3,36	10	2,72	3,09	3,36
8	3,43	3,89	4,32	8	3,43	3,89	4,32
6	4,32	4,91	5,73	6	4,32	4,91	5,73
4	5,45	6,18	7,26	4	5,45	6,18	7,26
2	6,87	7,78	—	2	6,87	7,78	—

TAB 10a

Viti / Coppia di serraggio
Screws / Torque
Vis / Couple de serrage
Schraube / Drehmoment

Viti	Screws	Vis	Schraube	Nm
>		≤		
—		1,6		0,1
1,6		2		0,2
2		2,8		0,4
2,8		3		0,5
3		3,2		0,6
3,2		3,6		0,8
3,6		4,1		1,2
4,1		4,7		1,8
4,7		5,3		2,0
5,3		6		2,5
6		8		3,5
8		10		4,0

TAB 10b

Cavi / trazione
Conductors / tensile
Conducteurs / traction
Leiter / Zugfestigkeit

mm²	N
0,2	10
0,34	15
0,5	20
0,75	30
1	35
1,5	40
2,5	50
4	60
6	80
10	90
16	100
25	135
35	190

TAB 10c

Cavi / rotazione
Conductors / rotation
Conducteurs / rotation
Leiter / Verdrehfestigkeit

mm²	dia hole	H	kg
0,2	6,4	260	0,2
0,34	6,4	260	0,2
0,5	6,5	260	0,3
0,75	6,5	260	0,4
1	6,5	260	0,4
1,5	6,5	280	0,4
2,5	9,5	280	0,7
4	9,5	280	0,9
6	9,5	280	1,4
10	9,5	280	2,0
16	13,0	300	2,9
25	13,0	300	4,5
35	14,5	300	6,8

Le correnti di prova sono generalmente indicate dalle normative di riferimento o dal produttore, e serve come base per l'omologazione dei prodotti. Se non diversamente specificato i valori nominali sono quelli mostrati nelle tabelle (TAB11a - TAB11b). Generalmente il rialzo termico dovuto al passaggio della corrente deve essere inferiore a 45°C per le normative Europee e di 30°C per le normative Americane.

Les courants d'essais sont généralement indiqués dans les normes de référence ou par le producteur, et servent de base pour l'homologation des produits. Sauf contre-indications les valeurs nominales sont celles indiquées dans les tableaux (TAB11a-TAB11b). Généralement l'échauffement dû au passage du courant doit être inférieur à 45°C pour les normes européennes et de 30°C pour les normes américaines.

The test currents are generally given by the relevant standards or by the manufacturer and are a basis for the approval of the products. When not specified, the values are those shown in the tables (TAB11a - TAB11b). Generally the temperature rise due to the current must be lower than 45°C for the European standards and 30°C for the American standards.

Im Allgemeinen werden die Testströme durch die relevanten Normen oder den Hersteller vorgegeben und sind Grundlage für die Zulassung der Produkte. Wenn nicht angegeben, gelten die Werte in den Tabellen (TAB11a - TAB11b). Grundsätzlich muss die durch den Strom bedingte Temperaturzunahme niedriger sein als 45°C bei der europäischen und 30°C bei der amerikanischen Norm.

TAB 11a

Sezione / Corrente (mm²/A)	Section / Current (mm²/A)								Section / Courant (mm²/A)								Querschnitt / Bemessungsstrom (mm²/A)																																			
Sezione Section Section Querschnitt	0,2	0,34	0,5	0,75	1	1,5	2,5	4	6	10	16	25	35	0,2	0,34	0,5	0,75	1	1,5	2,5	4	6	10	16	25	35	0,2	0,34	0,5	0,75	1	1,5	2,5	4	6	10	16	25	35	0,2	0,34	0,5	0,75	1	1,5	2,5	4	6	10	16	25	35
Corrente Current Courant Bemessungsstrom	4	5	6	9	13,5	17,5	24	32	41	57	76	101	125	4	5	6	9	13,5	17,5	24	32	41	57	76	101	125	4	5	6	9	13,5	17,5	24	32	41	57	76	101	125	4	5	6	9	13,5	17,5	24	32	41	57	76	101	125

TAB 11b

Sezione / Corrente (AWG/A)	Section / Current (AWG/A)								Section / Courant (AWG/A)								Querschnitt / Bemessungsstrom (AWG/A)																																											
Sezione Section Section Querschnitt	30	28	26	24	22	20	18	16	14	12	10	8	6	4	2	30	28	26	24	22	20	18	16	14	12	10	8	6	4	2	30	28	26	24	22	20	18	16	14	12	10	8	6	4	2	30	28	26	24	22	20	18	16	14	12	10	8	6	4	2
Corrente Current Courant Bemessungsstrom	0,5	0,8	1	2	3	5	7	10	15	20	30	50	65	85	115	0,5	0,8	1	2	3	5	7	10	15	20	30	50	65	85	115	0,5	0,8	1	2	3	5	7	10	15	20	30	50	65	85	115	0,5	0,8	1	2	3	5	7	10	15	20	30	50	65	85	115

PHILOSOPHY & VALUES

Responsibility with a big R

Focus on the Human foremost.

We, at Stelvio Kontek truly believe that corporate culture cannot endure without partnership and trust, either towards collaborators or partners and customers. Hence we take great care in optimizing our communication channels and define common win-win objectives. After all, best ideas necessarily come from individual.



Eco-responsibility

An investment on our future.

For us environmental responsibility doesn't only mean being green. It has to be a real and true doctrine flowing through all capillaries of our organization.

Thus, thanks to its Environmental Management System with ISO 14001 certification and its strong spirit of innovation, the group makes its own contribution to defending the environment as one of its top priorities through sustainable development: industrial wastewater is conditioned, air is protected with "end of pipe scrubbers", chemical substances are stocked in "double-jacket" tanks and the natural resources consumption is carefully monitored.



Global Compact

A human face to the global market.

The United Nations Global Compact is a call to companies everywhere to voluntarily align their operations and strategies with ten universally-accepted principles in the areas of human rights, labour, environment and anti-corruption, and to take action in support of UN goals, including the Millennium Development Goals.

Stelvio Kontek agrees on and takes part in the UN Global Compact platform for the development, implementation, and disclosure of responsible corporate policies and practices. Launched in 2000, it is the largest corporate responsibility initiative in the world, with over 10,000 signatories based in 140 countries.

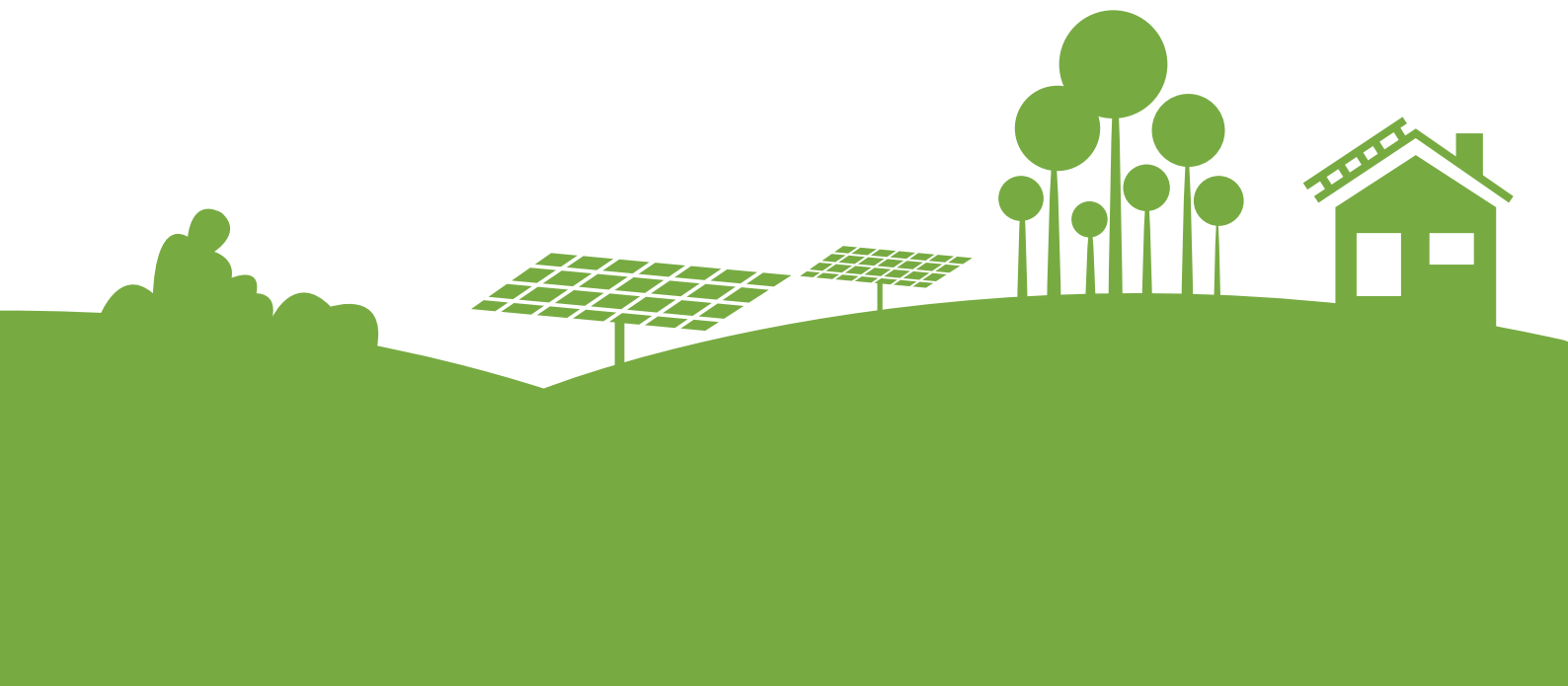

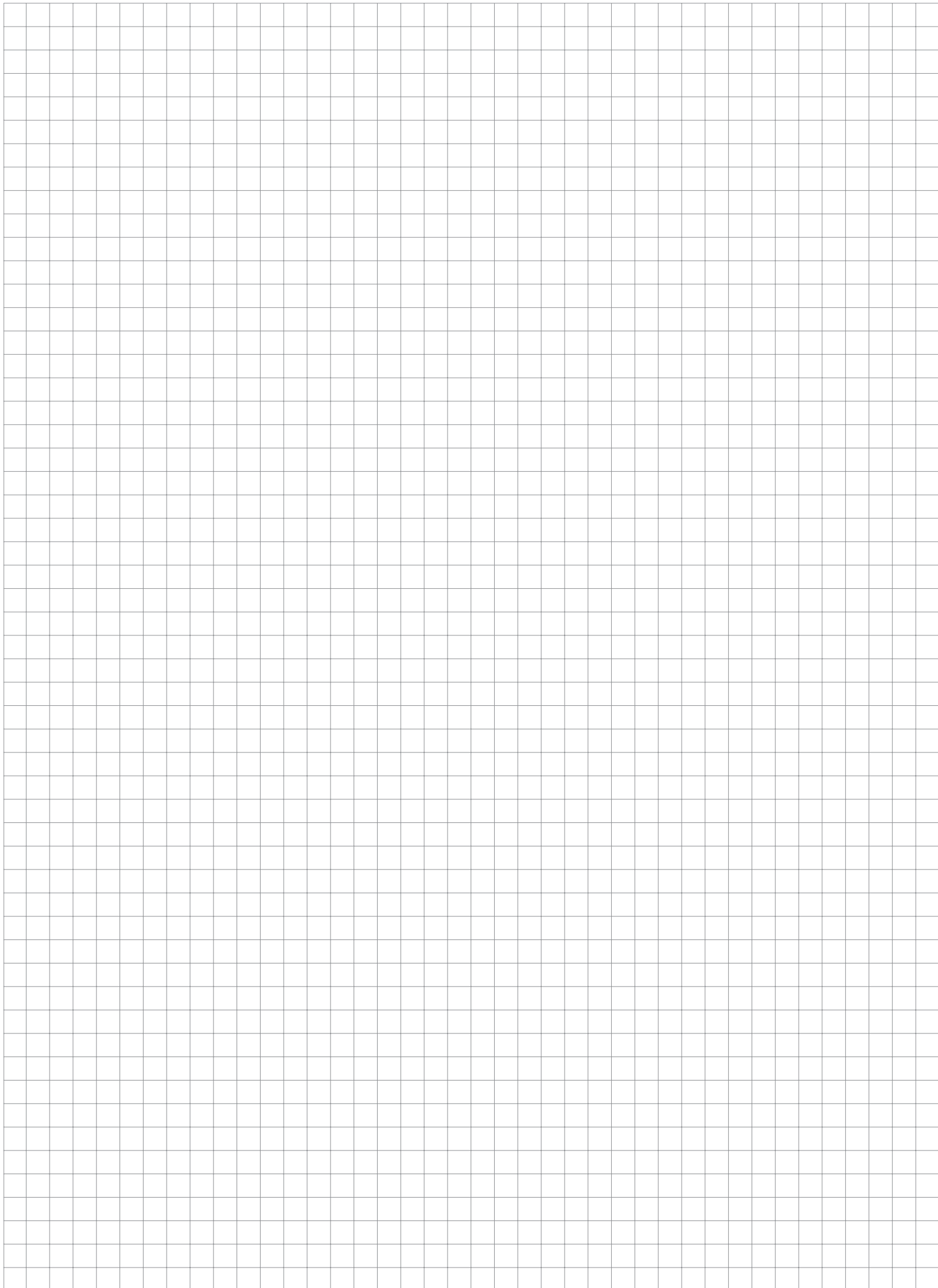

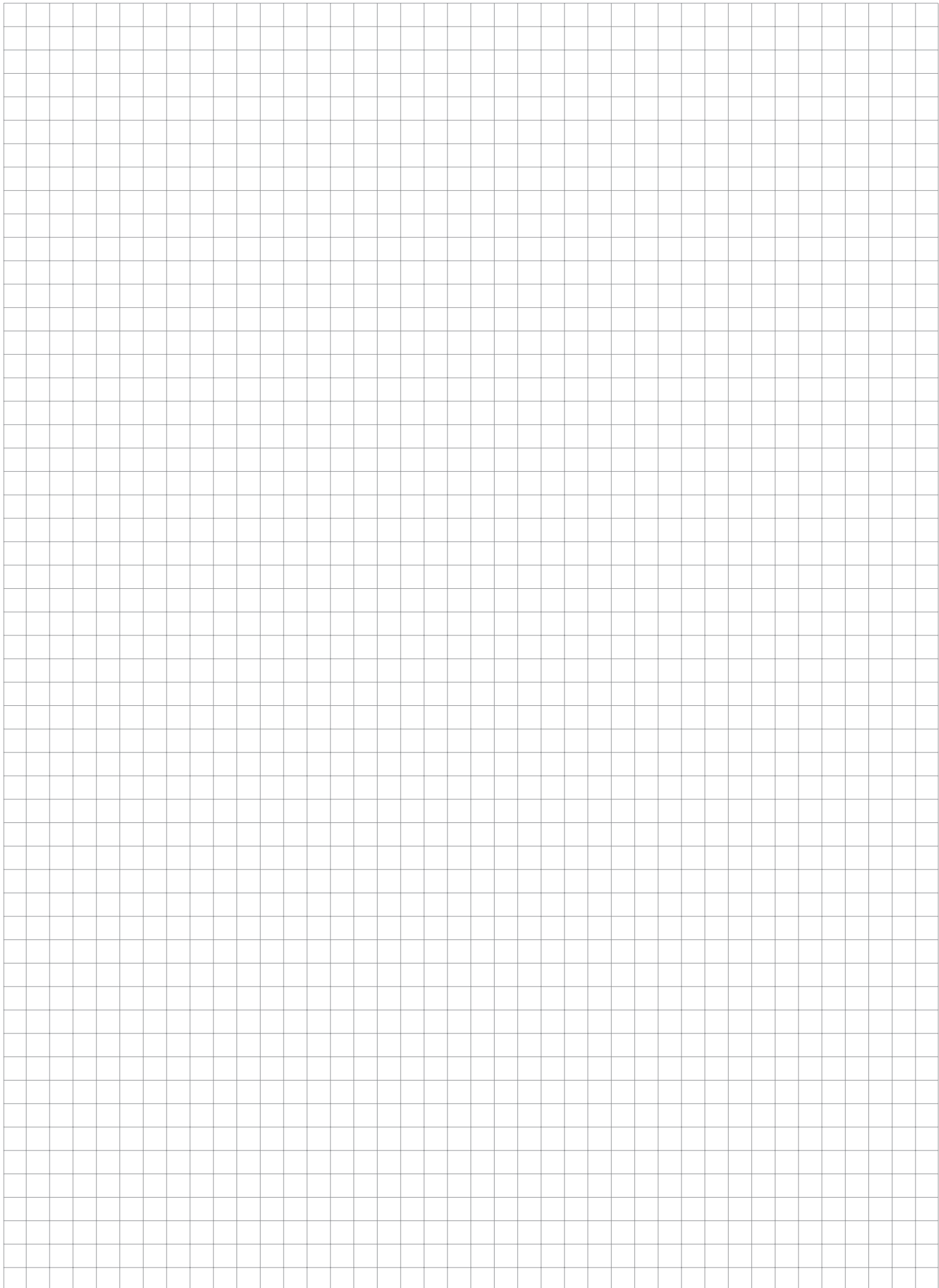

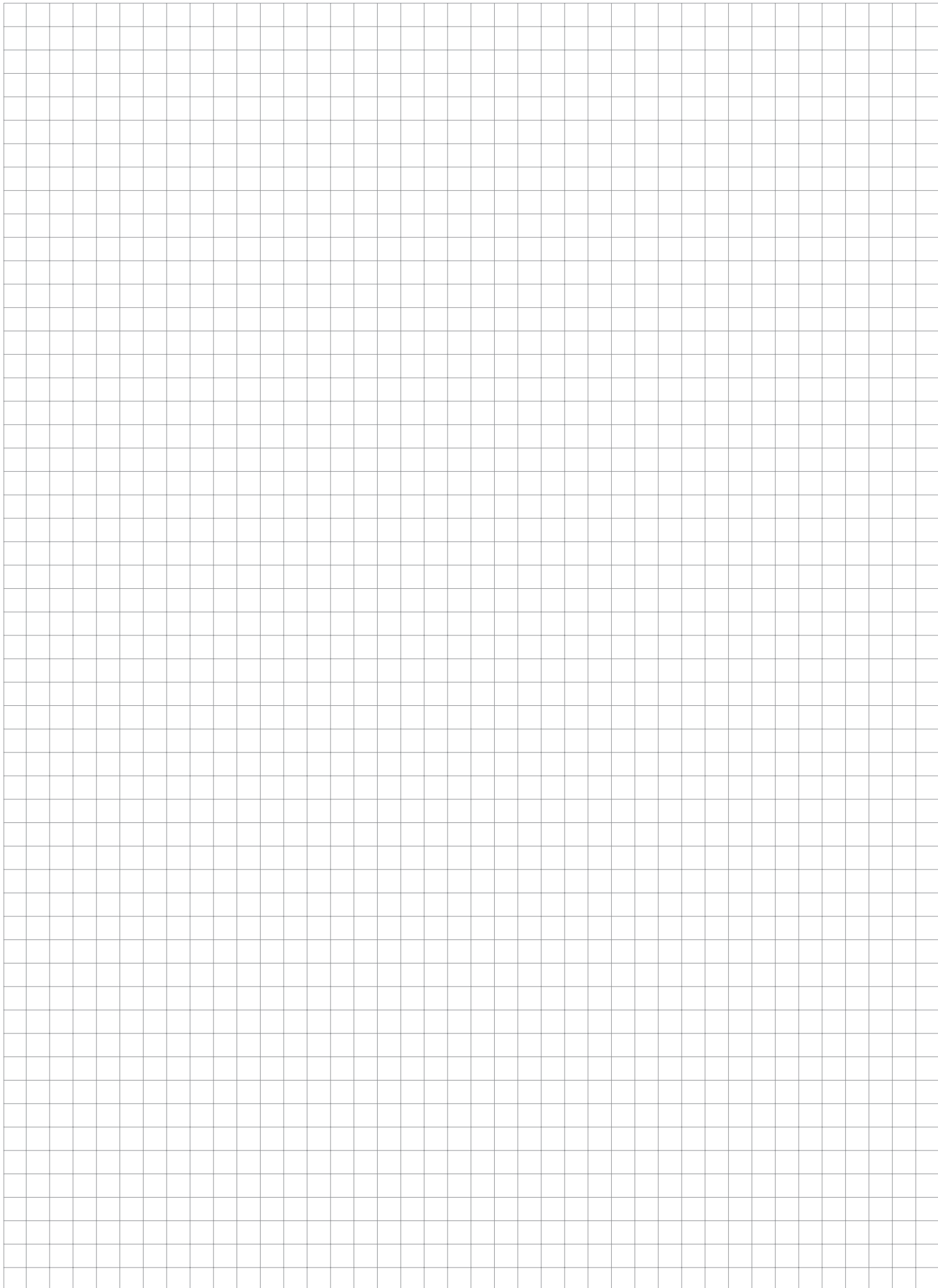

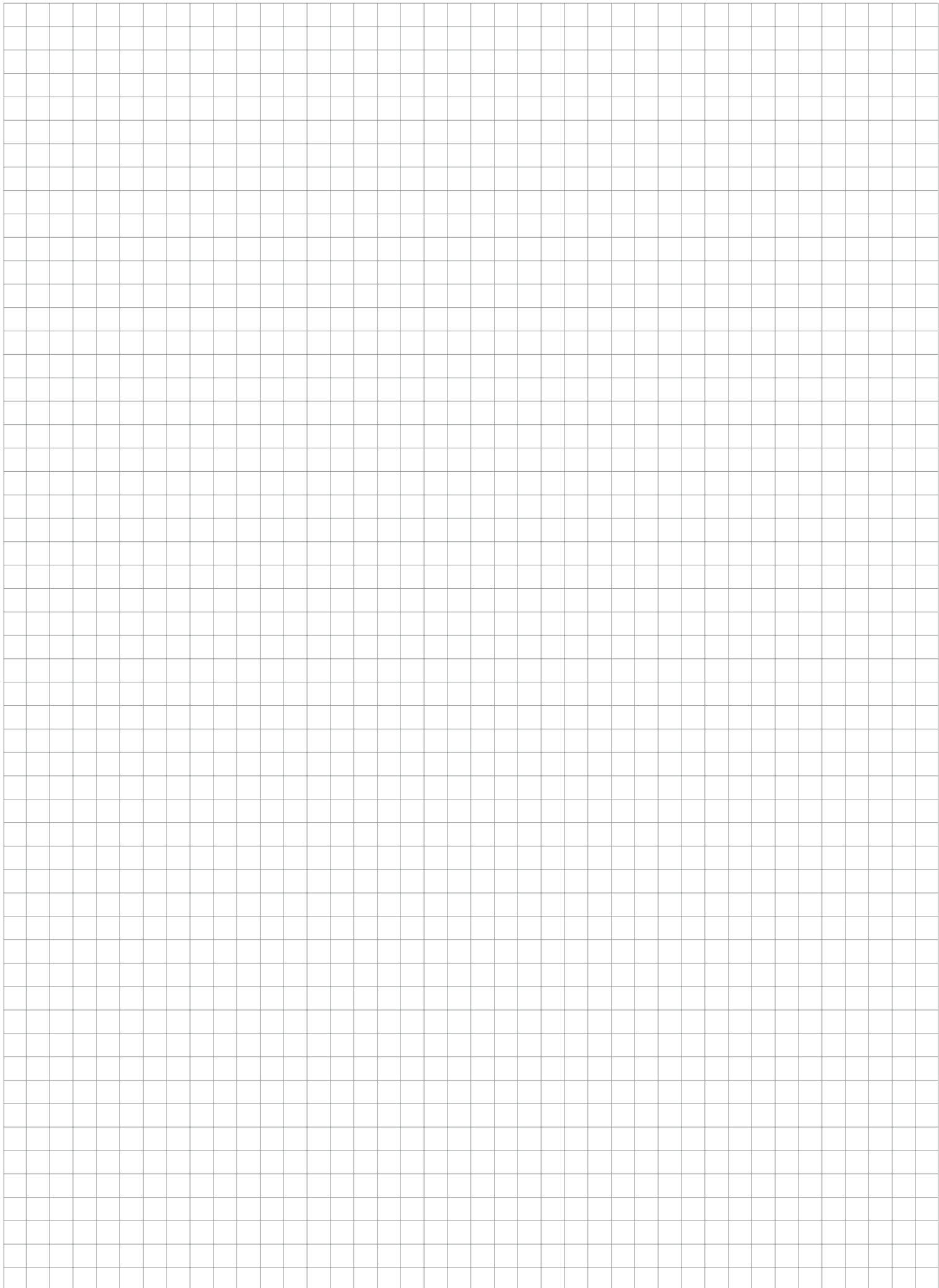



STAY CONNECTED WITH US.



 Stelvio Kontek
 @stelviokontek
 stelvio-kontek
blog.stelvio-kontek.com
www.stelvio-kontek.com

 **Stelvio Kontek S.p.A.**
Via al Mognago, 49
23848 Oggiono (LC) - Italy
T +39 0341 265411
F +39 0341 265400
info@stelvio-kontek.com

 **Stelvio Kontek LTD**
Unit 13, on 8 floor Yuen Fat Building
No 25 Wang Chiu Road
Kowloon Bay - Kowloon - Hong Kong
T +85227596121
F +85227590572
hk@stelvio-kontek.com

 **Stelvio Kontek SAS**
ZAC Butte Gayen 2
300 rue des Erables
94440 Santeny - France
T +33 (0)1 45 69 88 88
F +33 (0)1 45 99 23 72
sales@stelvio-kontek.fr
www.stelvio-kontek.fr

Discover the complete line of Stelvio Kontek's products

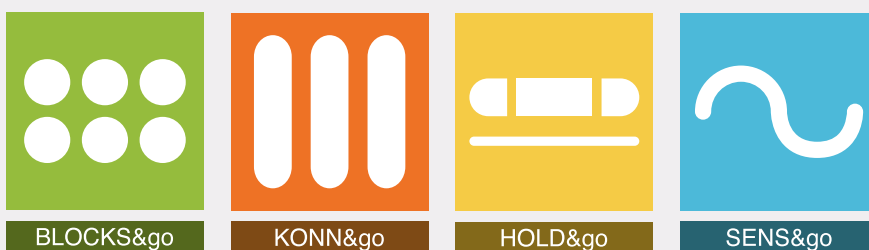

www.stelvio-kontek.com