

TC9243PG, TC9243FG

Infrared Remote Control Signal Transmission LSI

The TC9243PG, TC9243FG are infrared remote control signal transmission LSI which is suited for remote control of audio system, TV, VTR, CD player, etc.

Features

- Wide range of operating supply voltages, enabling low voltage operation.
: $V_{DD} = 2.0 \sim 4.0 \text{ V}$
- 32 functions are basically available.
Up to 112 instructions (28×4) can be output because multiple keying is possible.
- Interference with other equipment is prevented because 7 bits out of 8 bits of system code are presettable.
- With transmission display output pin.
- Low current dissipation.: $I_{QD} \leq 1 \mu\text{A}$ (at time of standby)
- Packages in two types; DIP and flat types are available.
DIP20: TC9243PG
SOP20: TC9243FG

Pin Assignment

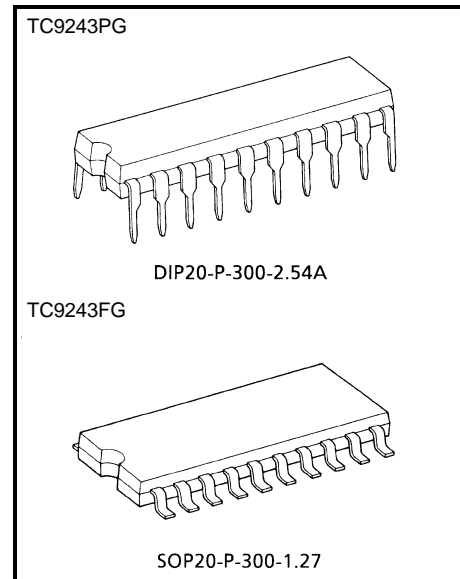
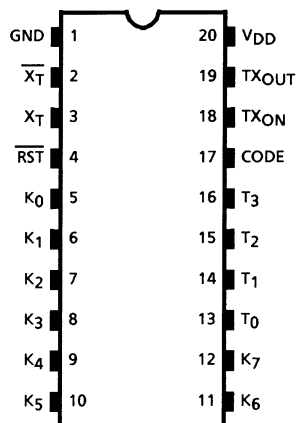

Weight
 DIP20-P-300-2.54A: 1.4 g (typ.)
 SOP20-P-300-1.27: 0.48 g (typ.)

Block Diagram

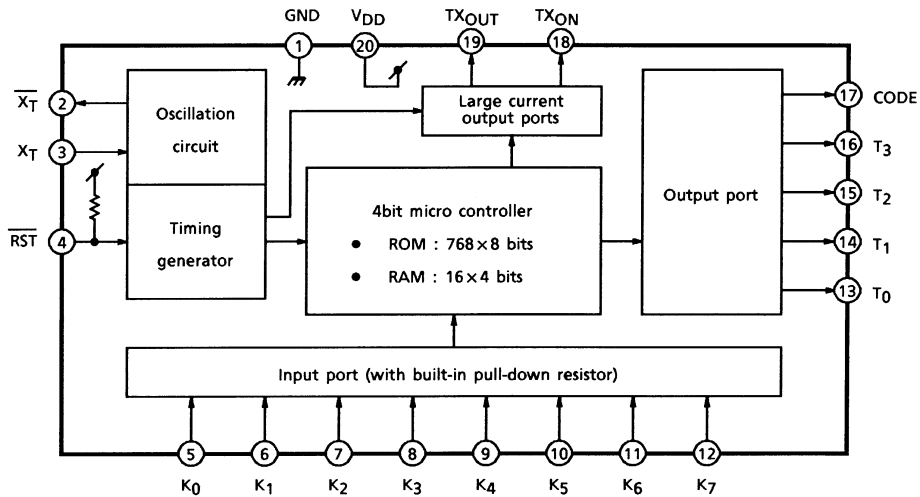

Pin Function

Pin No.	Symbol	Pin Name	Function and Operation
1	GND	Power Terminal	Applies supply voltage. ($V_{DD} = 2.0\sim 4.0\text{ V}$)
20	V_{DD}		
2	$\overline{X_T}$	Oscillator Terminal	Input/output terminals for the ceramic oscillators, with built-in amplifier circuit and feedback resistor.
3	X_T		
4	\overline{RST}	Reset Input	When this pin is set at "L" level, the inside is initialized. With a built-in pull-up resistor.
5-12	$K_0\sim K_7$	Key Inputs	The input terminals for Key Matrix. Each of all the pins has a built-in pull-down resistor.
13-16	$T_0\sim T_3$	Key Scan Output	The key matrix scan output terminals. CMOS output.
17	CODE	Code Scan Output	The scan output terminals for code setting. Pch open drain output.
18	TX_{ON}	Transmission Display Output	Transmission display LED driving output terminal.
19	TX_{OUT}	Transmission Output	Infrared LED driving output terminal.

Operations

1. Key Matrix

The TC9243PG, TC9243FG enables the setting of maximum 32 keys in combination of K₀~K₇ and T₀~T₃ keys. Further, System Codes are settable in 7 bits in combination of K₀~K₆ and CODE keys.

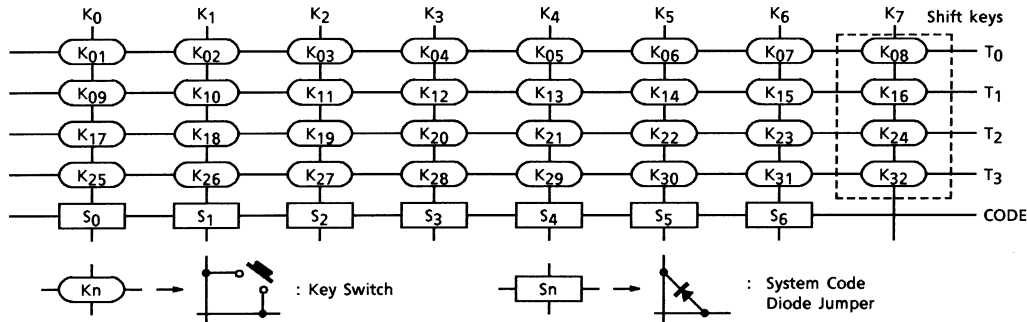

- K₀₈, 16, 24 and 32 (the shift key) keys can be pushed simultaneously with other keys (the normal keys). However, the simultaneous keying of the shift keys and that of the normal keys are prohibited.
- The system code setting is made by the diode jumper between “CODE” lines and “K₀~K₆” lines. With diode jumper, data code will become “1”. However, if the setting of “CODE” and “K₀~K₆” keys is only at one point, the keys are connectable directly without using the diode jumper. Further, “S₇” key is fixed at “1” and cannot be changed.

2. Data Format

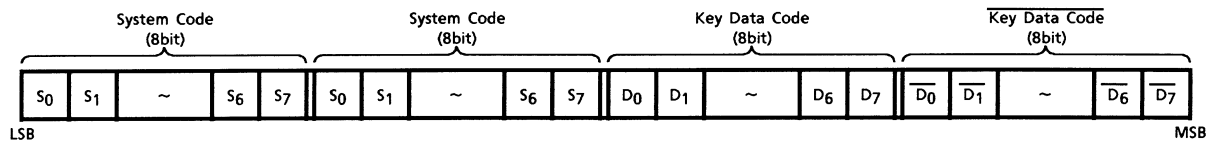

Note 1: “80H~8FH” out of the system codes are free codes.

These codes are freely usable but they might have been used by other equipment and therefore, there is the possibility of occurrence of interference.

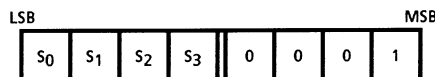

Other system codes have been customized and therefore, their general use is prohibited. Toshiba will assume no responsibility for interference and other problems which may result from use of other system coded.

3. Key Data Code

Key No.	Tn	Kn	D ₀	D ₁	D ₂	D ₃	D ₄	D ₅	D ₆	D ₇
K ₀₁	T ₀	K ₀	1	0	0	0	0	<ul style="list-style-type: none"> • Shift key data • "000" except dual keying. 		
K ₀₂		K ₁	0	1	0	0	0			
K ₀₃		K ₂	1	1	0	0	0			
K ₀₄		K ₃	0	0	1	0	0			
K ₀₅		K ₄	1	0	1	0	0			
K ₀₆		K ₅	0	1	1	0	0			
K ₀₇		K ₆	1	1	1	0	0			
K ₀₈		K ₇	<ul style="list-style-type: none"> • Normal key data • "00000" except dual keying. 					1	0	0
K ₀₉	T ₁	K ₀	1	0	0	1	0	<ul style="list-style-type: none"> • Shift key data • "000" except dual keying. 		
K ₁₀		K ₁	0	1	0	1	0			
K ₁₁		K ₂	1	1	0	1	0			
K ₁₂		K ₃	0	0	1	1	0			
K ₁₃		K ₄	1	0	1	1	0			
K ₁₄		K ₅	0	1	1	1	0			
K ₁₅		K ₆	1	1	1	1	0			
K ₁₆		K ₇	<ul style="list-style-type: none"> • Normal key data • "00000" except dual keying. 					1	1	0
K ₁₇	T ₂	K ₀	1	0	0	0	1	<ul style="list-style-type: none"> • Shift key data • "000" except dual keying. 		
K ₁₈		K ₁	0	1	0	0	1			
K ₁₉		K ₂	1	1	0	0	1			
K ₂₀		K ₃	0	0	1	0	1			
K ₂₁		K ₄	1	0	1	0	1			
K ₂₂		K ₅	0	1	1	0	1			
K ₂₃		K ₆	1	1	1	0	1			
K ₂₄		K ₇	<ul style="list-style-type: none"> • Normal key data • "00000" except dual keying. 					1	0	1
K ₂₅	T ₃	K ₀	1	0	0	1	1	<ul style="list-style-type: none"> • Shift key data • "000" except dual keying. 		
K ₂₆		K ₁	0	1	0	1	1			
K ₂₇		K ₂	1	1	0	1	1			
K ₂₈		K ₃	0	0	1	1	1			
K ₂₉		K ₄	1	0	1	1	1			
K ₃₀		K ₅	0	1	1	1	1			
K ₃₁		K ₆	1	1	1	1	1			
K ₃₂		K ₇	<ul style="list-style-type: none"> • Normal key data • "00000" except dual keying. 					1	1	1

- Normal key: K₀₁~K₀₇, K₀₉~K₁₅, K₁₇~K₂₃, K₂₅~K₃₁
- Shift key: K₀₈, K₁₆, K₂₄, K₃₂

4. TX_{OUT} Output Wave Form

Key ON

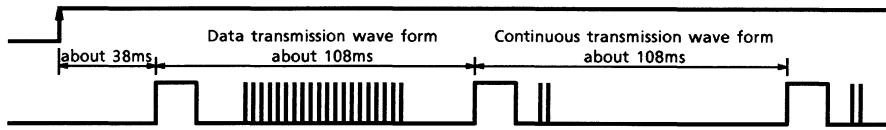

Note 2: In case of $f_{OSC} = 455 \text{ kHz}$

Data Transmission Wave Form

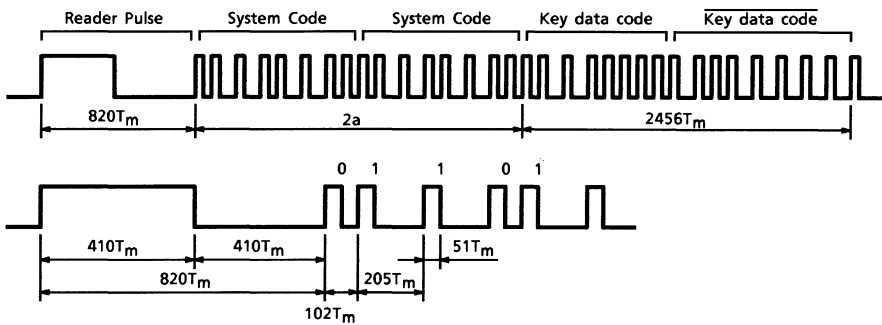

Continuous Transmission Wave Form

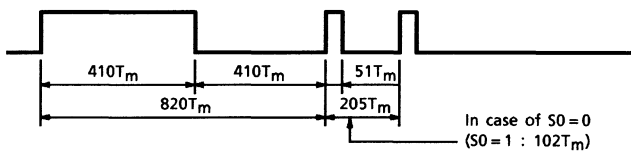

Carrier Wave Form

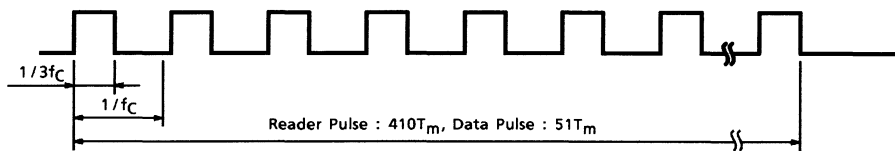

$T_m = 5/f_{OSC}$: System clock

a: System code output time

$f_c = f_{OSC}/12$

When oscillation frequency is 455 kHz, signal is output after pulse modulated by 37.9 kHz of duty 1/3, which is a 1/12 division by the carrier generation circuit.

Caution

In preparing a receiving software, strictly follow the following instructions:

- In case of system codes, the same code is transmitted twice and therefore, always decode these 2 codes and judge if they agree with each other.
- In case of key data codes, always decode a key data code and its reversed code and judge if they agree with each other.

Maximum Ratings (Ta = 25°C)

Characteristics	Symbol	Rating	Unit
Supply voltage	V _{DD}	-0.3~5.0	V
Input voltage	V _{IN}	V _{SS} - 0.3~V _{DD} + 0.3	V
Output current	I _{OUT}	-20	mA
Power dissipation	P _D	350 (300) (Note 3)	mW
Operating temperature	T _{opr}	-20~75	°C
Storage temperature	T _{stg}	-40~125	°C

Note 3: The value shown in parentheses applies to the TC9243FG.

Electrical Characteristics

Recommended Operating Conditions

(unless otherwise specified, V_{DD} = 3.0 V, Ta = 25°C, for items with an asterisk *, Ta = -25~75°C)

Characteristics		Symbol	Test Circuit	Test Condition	Min	Typ.	Max	Unit
Operating supply voltage *		V _{DD}	—	—	2.0	—	4.0	V
Oscillation frequency *		f _{OSC}	—	—	400	—	800	kHz
Input voltage	"H" level	V _{IH1}	—	(except \overline{RST})	V _{DD} × 0.7	—	V _{DD}	V
	"L" level	V _{IL1}	—	(except \overline{RST})	0	—	V _{DD} × 0.3	
Input voltage	"H" level	V _{IH2}	—	(\overline{RST})	V _{DD} × 0.8	—	V _{DD}	V
	"L" level	V _{IL2}	—	(\overline{RST})	0	—	V _{DD} × 0.2	

DC Characteristics (unless otherwise specified, V_{DD} = 3.0 V, Ta = 25°C)

Characteristics		Symbol	Test Circuit	Test Condition	Min	Typ.	Max	Unit
Operating supply current		I _{DD}	—	f _{OSC} = 455 kHz	—	—	1.0	mA
Static supply current		I _{QD}	—	At time of "Hold"	—	—	1.0	μA
Pull-down resistor		R _D	—	(K ₀ ~K ₇)	100	—	400	kΩ
Pull-up resistor		R _U	—	(\overline{RST})	25	—	100	kΩ
Output current	"H" level	I _{OH}	—	(TX _{OUT}) V _{OH} = 1.5 V	-10	—	—	mA
	"L" level	I _{OL}	—	(TX _{ON}) V _{OL} = 1.5 V	5	—	—	
Input leak current		I _{LI}	—	V _{IN} = V _{DD} , V _{SS}	-1.0	—	1.0	μA

Application Circuit

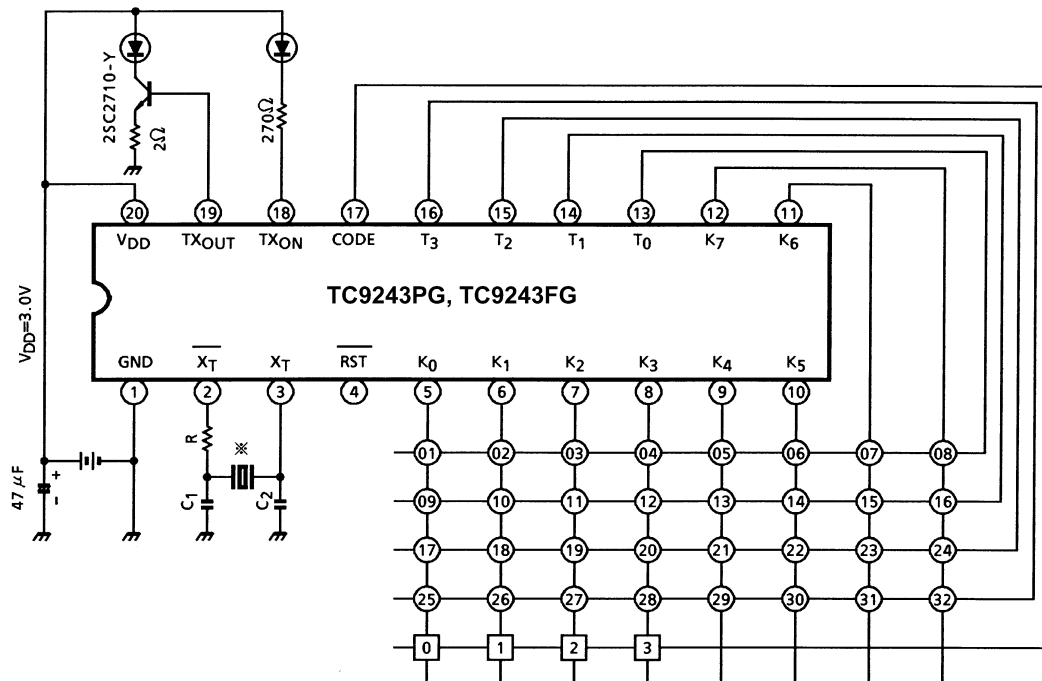

Note 4: Ceramic oscillator CSB455E (Murata Seisakusho) $C_1 = C_2 = 100 \text{ pF}$ $R = 6.8 \text{ k}\Omega$
 FCR455K3 (TDK) $C_1 = C_2 = 220 \text{ pF}$ $R = 2.2 \text{ k}\Omega$
 or equivalent

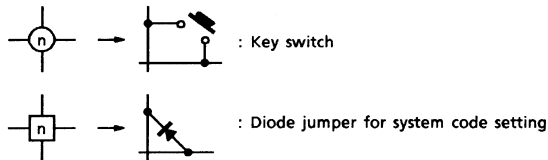

Package Dimensions

DIP20-P-300-2.54A

Unit : mm

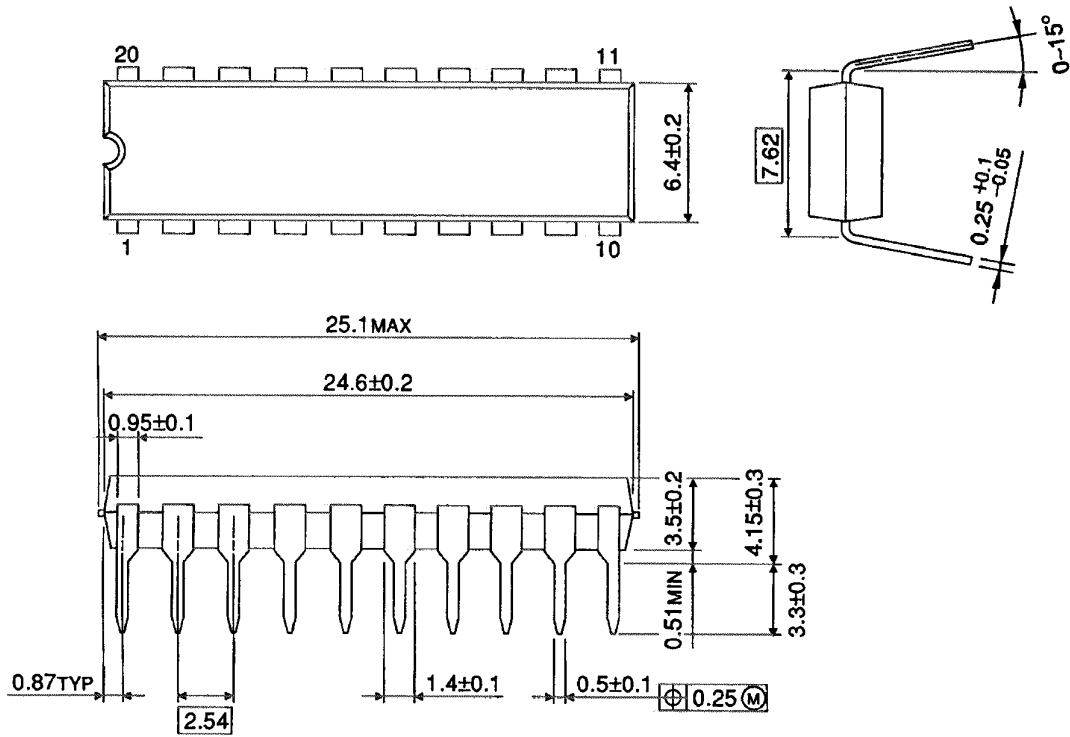

Weight: 1.4g (typ.)

Package Dimensions

SOP20-P-300-1.27

Unit : mm

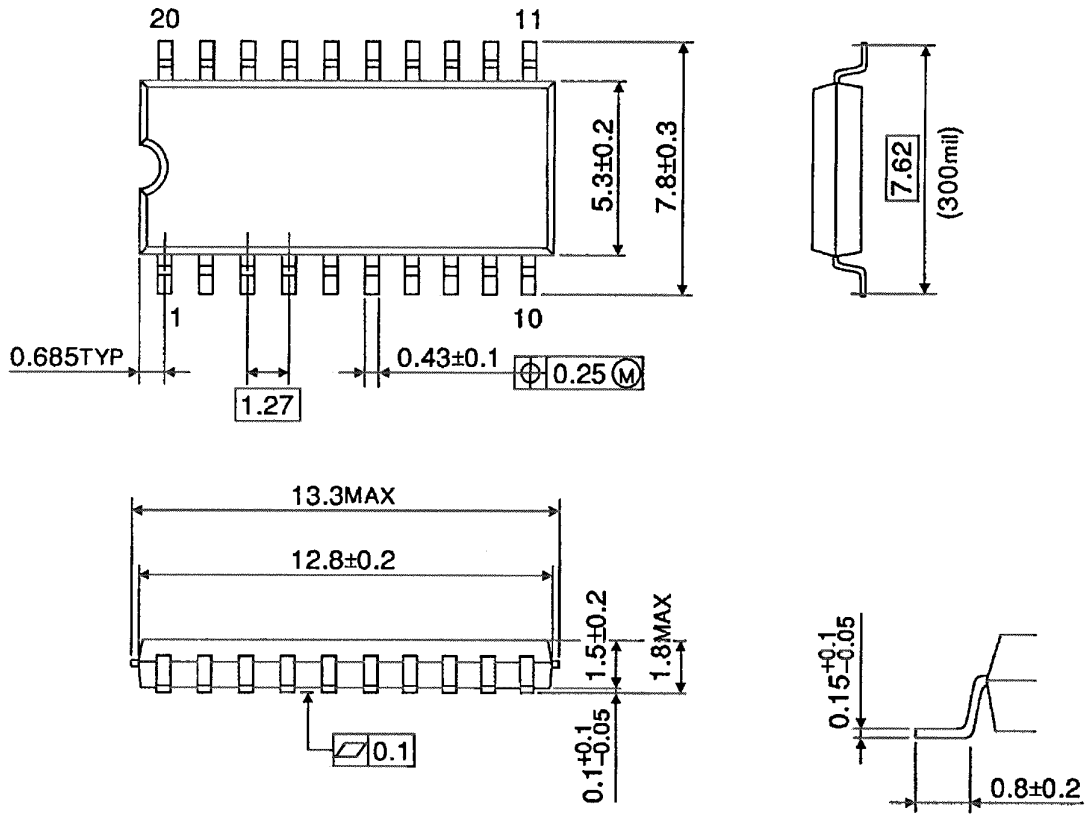

Weight: 0.48 g (typ.)

About solderability, following conditions were confirmed

- Solderability

- (1) Use of Sn-63Pb solder Bath

- solder bath temperature = 230°C
 - dipping time = 5 seconds
 - the number of times = once
 - use of R-type flux

- (2) Use of Sn-3.0Ag-0.5Cu solder Bath

- solder bath temperature = 245°C
 - dipping time = 5 seconds
 - the number of times = once
 - use of R-type flux

RESTRICTIONS ON PRODUCT USE

030619EBA

- The information contained herein is subject to change without notice.
- The information contained herein is presented only as a guide for the applications of our products. No responsibility is assumed by TOSHIBA for any infringements of patents or other rights of the third parties which may result from its use. No license is granted by implication or otherwise under any patent or patent rights of TOSHIBA or others.
- TOSHIBA is continually working to improve the quality and reliability of its products. Nevertheless, semiconductor devices in general can malfunction or fail due to their inherent electrical sensitivity and vulnerability to physical stress. It is the responsibility of the buyer, when utilizing TOSHIBA products, to comply with the standards of safety in making a safe design for the entire system, and to avoid situations in which a malfunction or failure of such TOSHIBA products could cause loss of human life, bodily injury or damage to property.
In developing your designs, please ensure that TOSHIBA products are used within specified operating ranges as set forth in the most recent TOSHIBA products specifications. Also, please keep in mind the precautions and conditions set forth in the "Handling Guide for Semiconductor Devices," or "TOSHIBA Semiconductor Reliability Handbook" etc..
- The TOSHIBA products listed in this document are intended for usage in general electronics applications (computer, personal equipment, office equipment, measuring equipment, industrial robotics, domestic appliances, etc.). These TOSHIBA products are neither intended nor warranted for usage in equipment that requires extraordinarily high quality and/or reliability or a malfunction or failure of which may cause loss of human life or bodily injury ("Unintended Usage"). Unintended Usage include atomic energy control instruments, airplane or spaceship instruments, transportation instruments, traffic signal instruments, combustion control instruments, medical instruments, all types of safety devices, etc.. Unintended Usage of TOSHIBA products listed in this document shall be made at the customer's own risk.
- The products described in this document are subject to the foreign exchange and foreign trade laws.
- TOSHIBA products should not be embedded to the downstream products which are prohibited to be produced and sold, under any law and regulations.