

GaAS MMIC LOW DISTORTION TRANSFER SWITCH DC - 2.0 GHz

SEPTEMBER 1999

Features

- HIGH THIRD ORDER INTERCEPT : +58 dBm
- SINGLE POSITIVE SUPPLY: +3 TO +8V
- HIGH POWER CAPABILITY
- TTL/CMOS CONTROL

General Description

The HMC159QS16 is a low-cost transfer switch in a 16-lead QSOP package for use in transmit-receive applications which require very low distortion at high signal power levels. The device can control signals up to 2.0GHz and is especially suited for 900MHz applications. The switch is used to exchange two antennae between transmitter and receiver, providing antenna diversity. The design has exceptional intermodulation performance; providing a +58dBm third order intercept at 8 Volt bias. On-chip circuitry allows single positive supply operation at very low DC current with control inputs compatible with CMOS and most TTL logic families. The QSOP 16-lead package occupies the same area as an 8-lead SOIC.

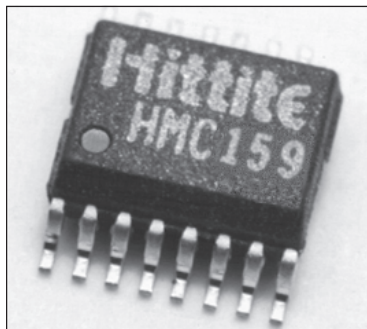

7

Switches

Guaranteed Performance, $V_{dd} = +5 V_{dc}$, 50 Ohm System, -40 to +85 deg C

Parameter	Frequency	Min.	Typ.	Max.	Units
Insertion Loss	DC - 0.5GHz		0.7	1.0	dB
	DC - 1.0GHz		0.9	1.2	dB
	DC - 2.0GHz		1.8	2.2	dB
Isolation	DC - 0.5GHz	27	30		dB
	DC - 1.0GHz	20	23		dB
	DC - 2.0GHz	16	19		dB
Return Loss	DC - 0.5GHz	18	22		dB
	DC - 1.0GHz	14	17		dB
	DC - 2.0GHz	9	11		dB
Input Power for 1dB Compression Control	0/8V	0.5 - 1.0GHz 0.5 - 2.0GHz	35 35	37 37	dBm
Input Third Order Intercept	0/8V Control	0.5 - 1.0GHz 0.5 - 2.0GHz	50 50	58 58	dBm
Switching Characteristics	DC - 2.0GHz				
tRISE, tFALL (10/90% RF)			22		ns
tON, tOFF (50% CTL to 10/90% RF)			50		ns

HMC159QS16 LOW DISTORTION TRANSFER SWITCH DC - 2.0 GHz

SEPTEMBER 1999

Insertion Loss

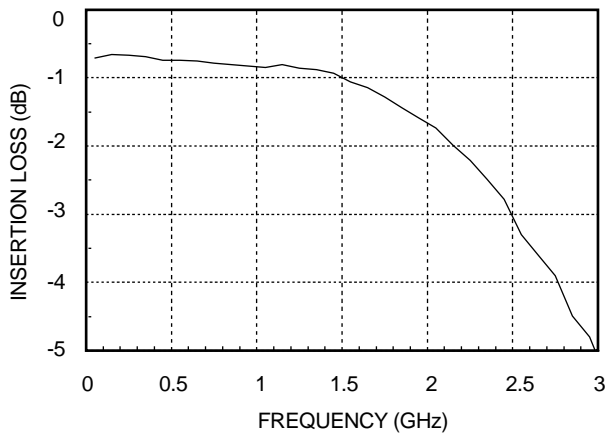

Isolation

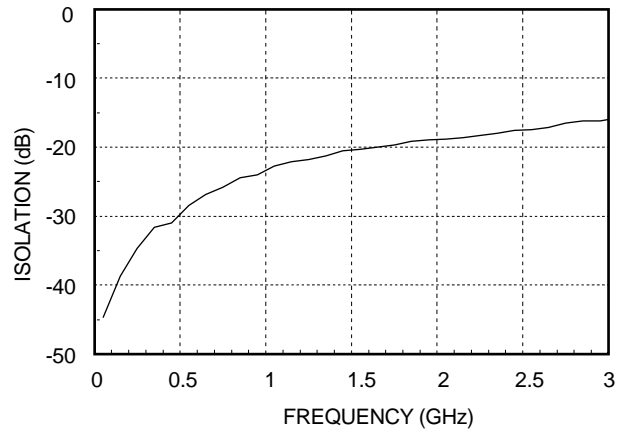

Return Loss

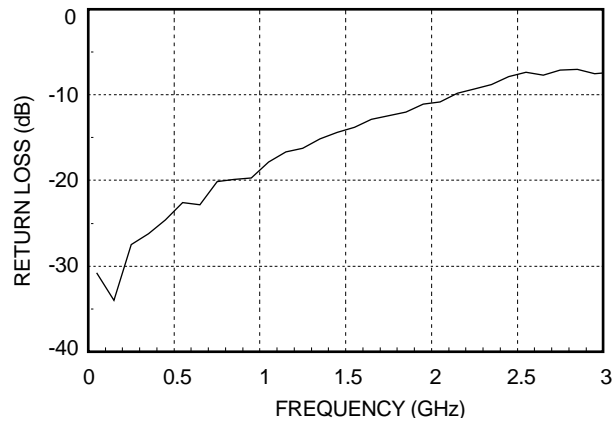

S - Parameter data is available On-Line at www.hittite.com

HMC159QS16 LOW DISTORTION TRANSFER SWITCH DC - 2.0 GHz

SEPTEMBER 1999

Input 0.1 and 1.0 dB Compression vs Bias Voltage

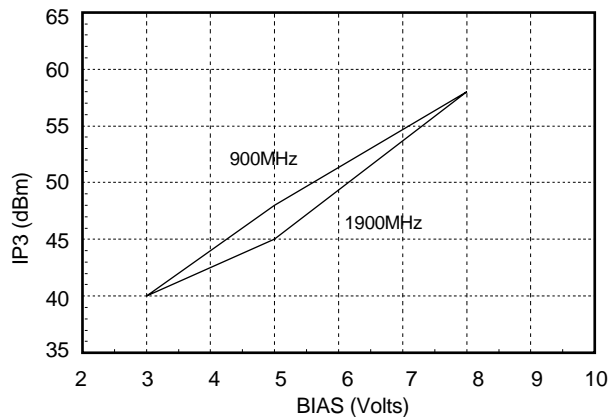

Input Third Order Intercept vs Bias Voltage

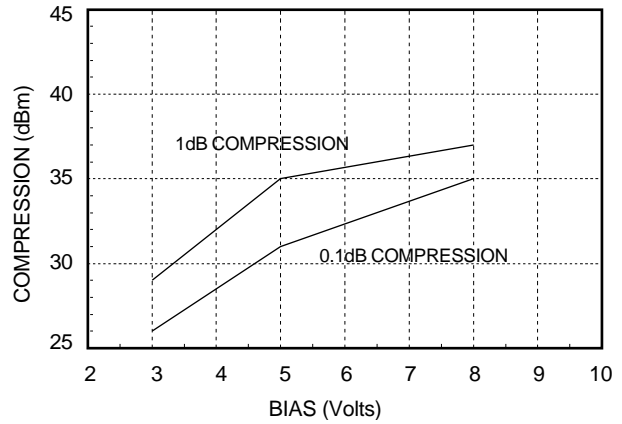

7

Compression vs Bias Voltage

Bias (Volts)	Carrier at 900MHz		Carrier at 1900MHz	
	Input Power for 0.1dB Compression	Input Power for 1dB Compression	Input Power for 0.1dB Compression	Input Power for 1dB Compression
	(dBm)	(dBm)	(dBm)	(dBm)
3	26	29	26	29
5	31	35	31	35
8	35	37	35	37

Distortion vs Bias Voltage

Bias (Volts)	1 Watt Carrier at 900MHz			1 Watt Carrier at 1900MHz		
	Third Order Intercept	Second Order Intercept	Second Harmonic	Third Order Intercept	Second Order Intercept	Second Harmonic
	(dBm)	(dBm)	(dBc)	(dBm)	(dBm)	(dBc)
3	40	68	43	40	82	56
5	48	80	53	45	90	60
8	58	89	64	58	90	70

Caution: Do not operate in 1dB compression at power levels above +35dBm.

Switches

HMC159QS16 LOW DISTORTION TRANSFER SWITCH DC - 2.0 GHZ

SEPTEMBER 1999

Functional Diagram

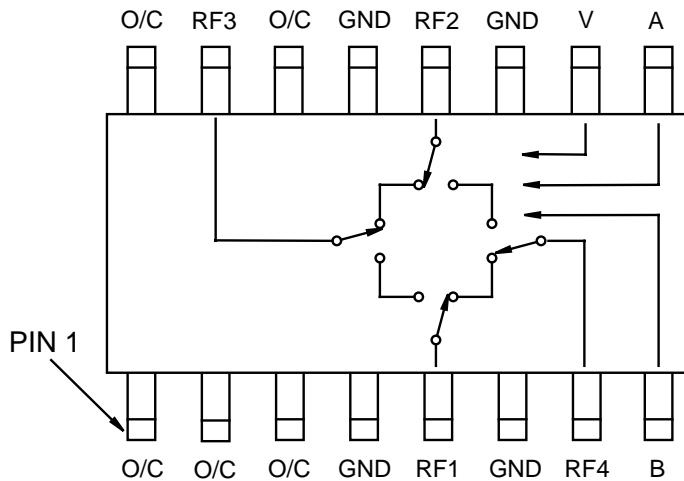

Absolute Maximum Ratings

Bias Voltage Range (Vdd)	-0.2 to +12 Vdc
Control Voltage Range (A & B)	-0.2 to +Vdd Vdc
Storage Temperature	-65 to +150 deg C
Operating Temperature	-40 to +85 deg C

Truth Table

Control Input		Signal Path State			
A	B	RF1-RF3	RF1-RF4	RF2-RF3	RF2-RF4
Low	High	ON	OFF	OFF	ON
High	Low	OFF	ON	ON	OFF

Control Voltage

State	Bias Condition
Low	0 to -0.2V @ 20uA Max.
High	+3V@50uA Typ to +8V@500uA Max

Logic High control voltage must be in the range of $V-0.2$ to V where V is the applied bias voltage. Recommended bias voltage V is +3 to +8 Volts. Redundant A, B, and V ports are provided.

HMC159QS16 LOW DISTORTION TRANSFER SWITCH DC - 2.0 GHZ

SEPTEMBER 1999

Outline

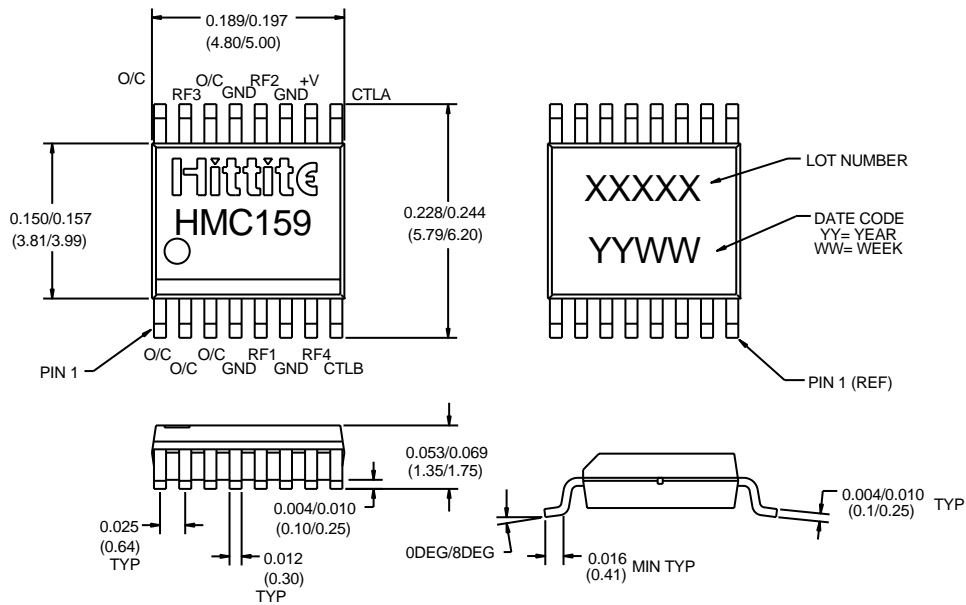

- 1) MATERIAL:
 - A) PACKAGE BODY LOW STRESS INJECTION MOLDED PLASTIC, SILICA & SILICONE IMPREGNATED
 - B) LEADFRAME MATERIAL: COPPER ALLOY
2. PLATING: LEAD-TIN SOLDER PLATE
3. DIMENSIONS ARE IN INCHES (MILLIMETERS) UNLESS OTHERWISE SPECIFIED TOL. ARE $\pm 0.005 (\pm 0.13)$

Typical Application Circuit

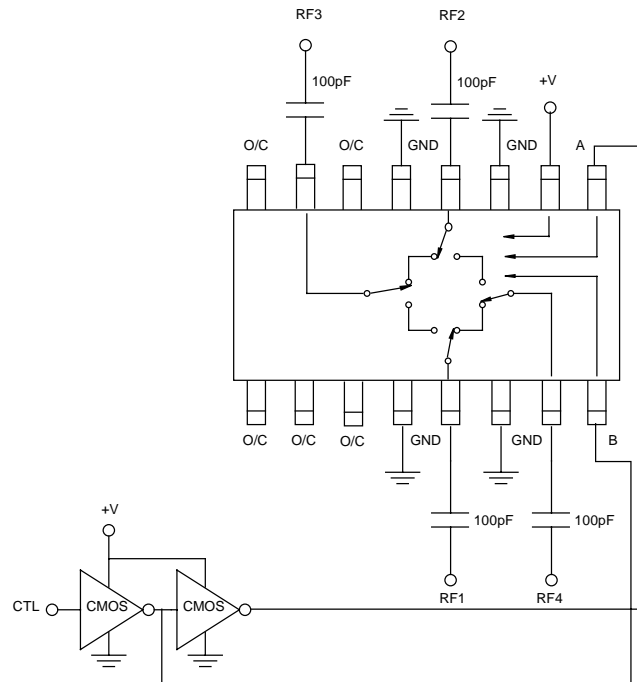

Notes:

1. Control inputs A and B can be driven directly with CMOS logic (HC) with V of 3 to 8 Volts applied to the CMOS logic gates and to pin V of the RF switch.
2. DC Blocking capacitors are required for each RF port as shown. Capacitor value determines lowest frequency of operation.
3. Highest RF signal power capability is achieved with V set to +8V. However, the switch will operate properly (but at lower RF power capability) at bias voltages down to +3V.
4. Set V to 5 Volts and use HCT series logic to provide a TTL driver interface.