

# CERAMIC SMD TYPE

## 32.768 kHz (SCO-53)

- High Stability with AT-Cut crystal
- External Dimensions : 5.0 × 3.2 mm
- 1.5 V to 3.3 V Operating Supply Voltage Range
- CMOS Output
- Tri-state Function Available



### ■ ELECTRICAL SPECIFICATIONS

ITEM	Value	Remarks
Output Logic Type	CMOS	CMOS XO
Frequency	32.768 kHz	
Supply Voltage(V <sub>DD</sub> )	1.5 V <sub>DC</sub> ±5 %, 1.8 V <sub>DC</sub> ±5 %, 2.5 V <sub>DC</sub> ±5 % 3.3 V <sub>DC</sub> ±5 %	
Operating Temperature Range	0 to +70 °C, -20 to +70 °C, -40 to +85 °C	
Storage Temperature Range	-55 to +125 °C	
Frequency Stability	±20 ppm, ±25 ppm, ±50 ppm, ±100 ppm Max.	Over operating temperature range
Input Current	0.7 mA(1.5 V <sub>DC</sub> , 1.8 V <sub>DC</sub> ), 1.5 mA(2.5 V <sub>DC</sub> , 3.3 V <sub>DC</sub> )	
Output Voltage Logic High(V <sub>OH</sub> )	90 % of V <sub>DD</sub> Min.	
Output Voltage Logic Low(V <sub>OL</sub> )	10 % of V <sub>DD</sub> Max.	
Rise / Fall Time	200 ns Max.	Measured over 10 % to 90 % of waveform
Duty Cycle	45 to 55 %, 40 to 60 %	Measured at 50 % of waveform
Start-up Time	3 ms Max.	
Output Load Condition(CMOS)	15 pF Max.	
Output Enable Function (V <sub>IH</sub> and V <sub>IL</sub> )	70 % of V <sub>DD</sub> Min. to Enable Output 30 % of V <sub>DD</sub> Max. to Disable Output	High Impedance
Frequency Aging	±5 ppm Max.	25°C, First year

### ■ MECHANICAL DIMENSIONS (mm)

(mm)

### ■ LAND PATTERN (mm)

(mm)

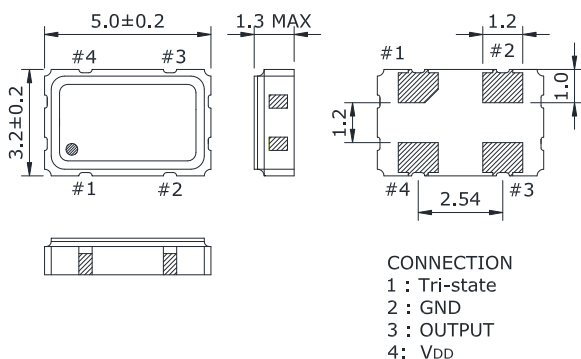

&lt;Top View&gt;

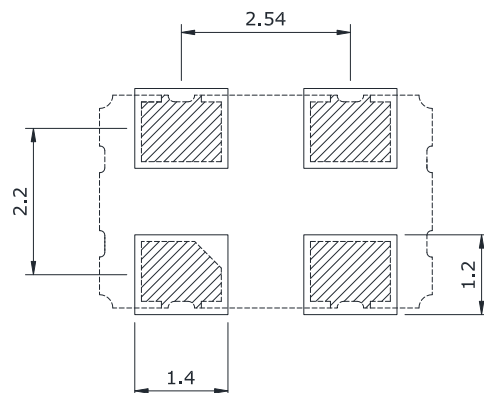

**■ PART NUMBERING GUIDE**

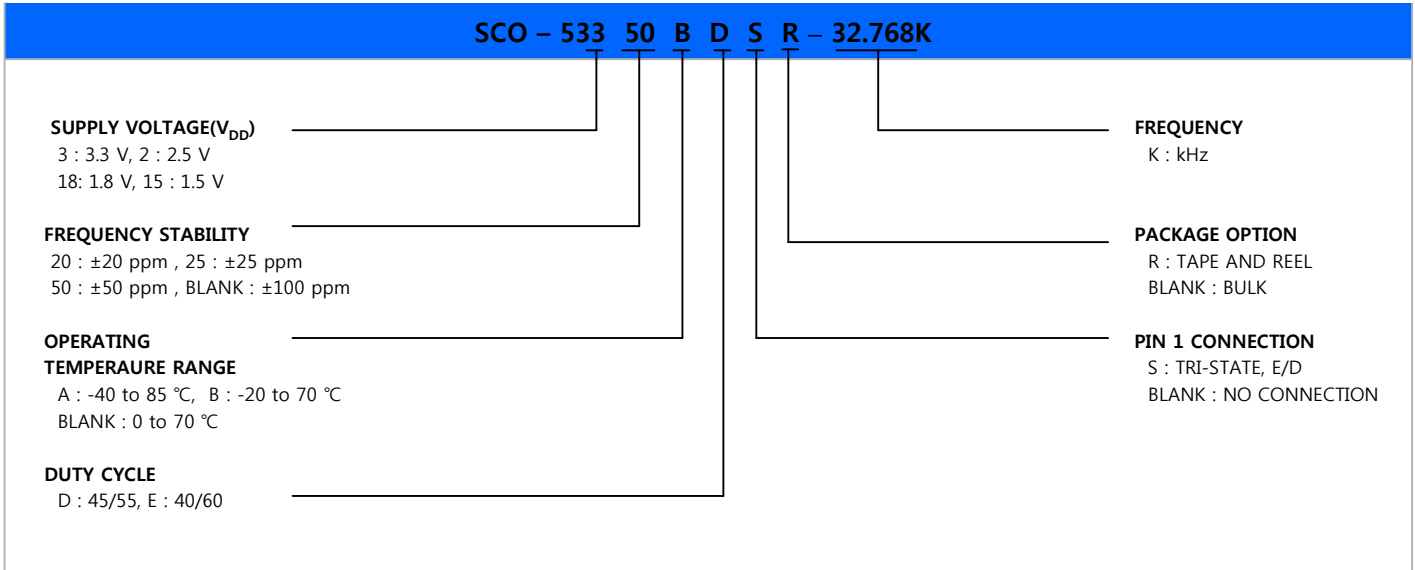

**■ TEST CIRCUIT (CMOS)**

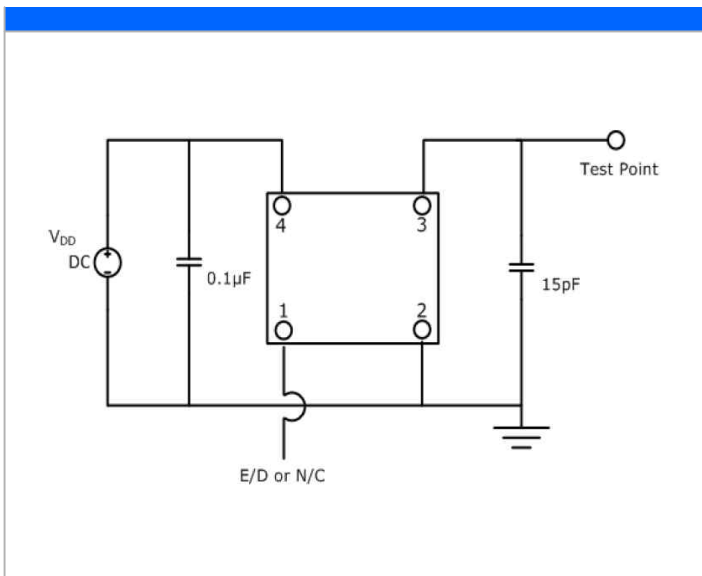

**■ WAVEFORM (CMOS)**

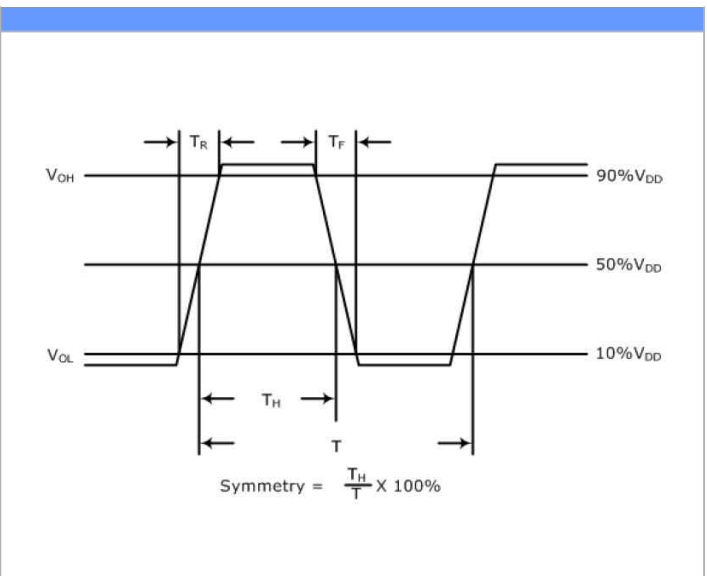

**■ ENVIRONMENTAL & MECHANICAL SPECIFICATIONS**

Temperature Cycling	MIL-STD-883, Method 1010, Condition B
Fine Leak Test	MIL-STD-883, Method 1014, Condition A
Gross Leak Test	MIL-STD-883, Method 1014, Condition C
Mechanical Shock	MIL-STD-883, Method 2002, Condition B
Vibration	MIL-STD-883, Method 2007, Condition A
Moisture Resistance	MIL-STD-883, Method 1004
Moisture Sensitivity	J-STD-020, MSL 1
Resistance to Soldering Heat	MIL-STD-202, Method 210, Condition K
Solderability	MIL-STD-883, Method 2003

**REFLOW PROFILE**

**MARKING GUIDE**

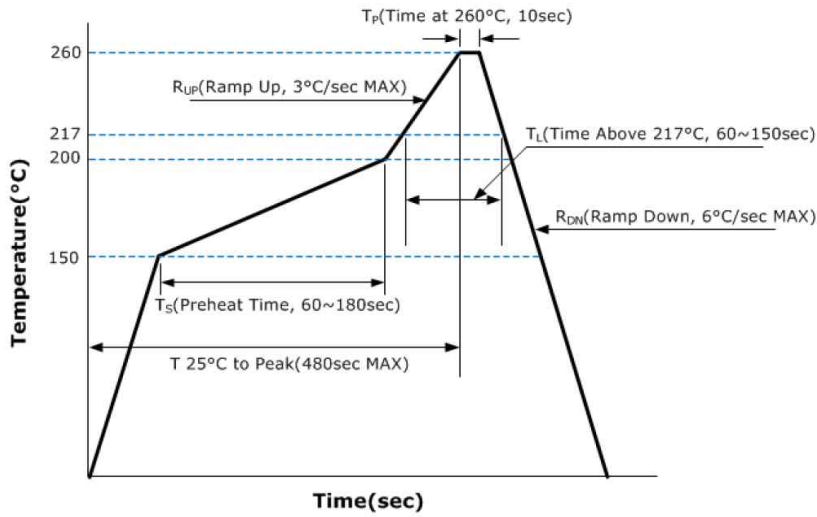

LINE 1 : 32.768K

LINE 2 : ● S YY WW

Sunny

Year

Week

kHz

**TAPE AND REEL DIMENSIONS**

MAT'L : P.S  
 COLOR : WHITE&BLACK  
 REFERENCE R=0.2

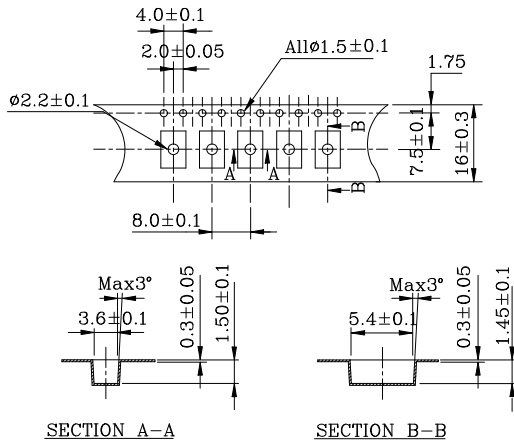

MAT'L : P.S  
 COLOR : WHITE&BLACK

