



CD4043BM/CD4043BC Quad TRI-STATE[®] NOR R/S Latches

CD4044BM/CD4044BC Quad TRI-STATE NAND R/S Latches

General Description

CD4043BM/CD4043BC are quad cross-couple TRI-STATE CMOS NOR latches, and CD4044BM/CD4044BC are quad cross-couple TRI-STATE CMOS NAND latches. Each latch has a separate Q output and individual SET and RESET inputs. There is a common TRI-STATE ENABLE input for all four latches. A logic "1" on the ENABLE input connects the latch states to the Q outputs. A logic "0" on the ENABLE input disconnects the latch states from the Q outputs resulting in an open circuit condition on the Q output. The TRI-STATE feature allows common bussing of the outputs.

Features

- Wide supply voltage range 3V to 15V
- Low power 100 nW (typ.)
- High noise immunity 0.45 V_{DD} (typ.)
- Separate SET and RESET inputs for each latch
- NOR and NAND configuration
- TRI-STATE output with common output enable

Applications

- Multiple bus storage
- Strobed register
- Four bits of independent storage with output enable
- General digital logic

Connection Diagrams

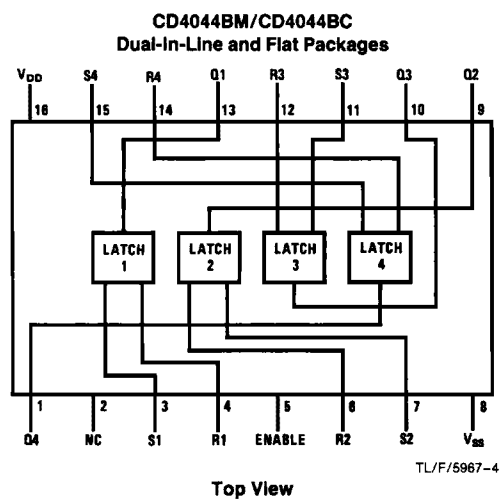
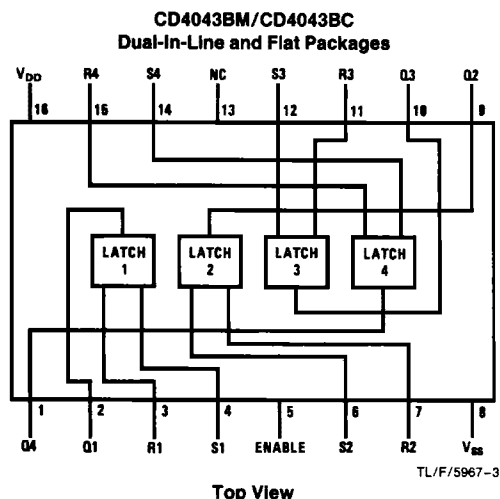

Truth Table

CD4043BM/CD4043BC			
S	R	E	Q
X	X	0	OC
0	0	1	NC
1	0	1	1
0	1	1	0
1	1	1	Δ

CD4044BM/CD4044BC			
S	R	E	Q
X	X	0	OC
1	1	1	NC
0	1	1	1
1	0	1	0
0	0	1	ΔΔ

Order Number CD4043B* or CD4044B*

*Please look into Section 8, Appendix D for availability of various package types.

- OC — TRI-STATE
- NC — No change
- X — Don't care
- Δ — Dominated by S = 1 input
- ΔΔ — Dominated by R = 0 input

Absolute Maximum Ratings (Notes 1 and 2)

If Military/Aerospace specified devices are required, contact the National Semiconductor Sales Office/Distributors for availability and specifications.

Supply Voltage (V_{DD})	-0.5V to +18V
Input Voltage (V_{IN})	-0.5V to V_{DD} + 0.5V
Storage Temperature Range (T_S)	-65°C to +150°C
Power Dissipation (P_D)	
Dual-In-Line	700 mW
Small Outline	500 mW
Lead Temperature (T_L)	
(Soldering, 10 seconds)	260°C

Recommended Operating Conditions (Note 2)

Supply Voltage (V_{DD})	3.0V to 15V
Input Voltage (V_{IN})	0 to V_{DD} V
Operating Temperature Range (T_A)	
CD4043BM, CD4044BM	-55°C to +125°C
CD4043BC, CD4044BC	-40°C to +85°C

DC Electrical Characteristics CD4043BM/CD4044BM (Note 2)

Symbol	Parameter	Conditions	-55°C		+25°C			+125°C		Units
			Min	Max	Min	Typ	Max	Min	Max	
I_{DD}	Quiescent Device Current	$V_{DD} = 5V, V_{IN} = V_{DD}$ or V_{SS}		5.0		0.01	5.0		150	μA
		$V_{DD} = 10V, V_{IN} = V_{DD}$ or V_{SS}		10		0.01	10		300	μA
		$V_{DD} = 15V, V_{IN} = V_{DD}$ or V_{SS}		20		0.02	20		600	μA
V_{OL}	Low Level Output Voltage	$ I_O \leq 1 \mu A, V_{IL} = 0V, V_{IH} = V_{DD}$								
		$V_{DD} = 5.0V$		0.05		0	0.05		0.05	V
		$V_{DD} = 10V$		0.05		0	0.05		0.05	V
		$V_{DD} = 15V$		0.05		0	0.05		0.05	V
V_{OH}	High Level Output Voltage	$ I_O \leq 1 \mu A, V_{IL} = 0V, V_{IH} = V_{DD}$								
		$V_{DD} = 5.0V$	4.95		4.95	5.0		4.95		V
		$V_{DD} = 10V$	9.95		9.95	10		9.95		V
		$V_{DD} = 15V$	14.95		14.95	15		14.95		V
V_{IL}	Low Level Input Voltage	$ I_O \leq 1 \mu A$								
		$V_{DD} = 5.0V, V_O = 0.5V$ or $4.5V$		1.5		2.25	1.5		1.5	V
		$V_{DD} = 10V, V_O = 1.0V$ or $9.0V$		3.0		4.5	3.0		3.0	V
		$V_{DD} = 15V, V_O = 1.5V$ or $13.5V$		4.0		6.75	4.0		4.0	V
V_{IH}	High Level Input Voltage	$ I_O \leq 1 \mu A$								
		$V_{DD} = 5.0V, V_O = 0.5V$ or $4.5V$	3.5		3.5	2.75		3.5		V
		$V_{DD} = 10V, V_O = 1.0V$ or $9.0V$	7.0		7.0	5.5		7.0		V
		$V_{DD} = 15V, V_O = 1.5V$ or $13.5V$	11		11	8.25		11		V
I_{OL}	Low Level Output Current	$V_{IL} = 0V, V_{IH} = V_{DD}$								
		$V_{DD} = 5.0V, V_O = 0.4V$	0.64		0.51	1.0		0.36		mA
		$V_{DD} = 10V, V_O = 0.5V$	1.6		1.3	2.6		0.9		mA
		$V_{DD} = 15V, V_O = 1.5V$	4.2		3.4	6.8		2.4		mA
I_{OH}	High Level Output Current	$V_{IL} = 0V, V_{IH} = V_{DD}$								
		$V_{DD} = 5.0V, V_O = 4.6V$	-0.64		-0.51	-0.4		-0.36		mA
		$V_{DD} = 10V, V_O = 9.5V$	-1.6		-1.3	-1.0		-0.9		mA
		$V_{DD} = 15V, V_O = 13.5V$	-4.2		-3.4	-3.0		-2.4		mA
I_{IN}	Input Current	$V_{DD} = 15V, V_{IN} = 0V$		-0.1		-10^{-5}	-0.1		-1.0	μA
		$V_{DD} = 15V, V_{IN} = 15V$		0.1		10^{-5}	0.1		1.0	μA

DC Electrical Characteristics CD4043BC/CD4044BC (Note 2)

Symbol	Parameter	Conditions	-40°C		+25°C			+85°C		Units
			Min	Max	Min	Typ	Max	Min	Max	
I_{DD}	Quiescent Device Current	$V_{DD} = 5V, V_{IN} = V_{DD}$ or V_{SS}		20		0.01	20		150	μA
		$V_{DD} = 10V, V_{IN} = V_{DD}$ or V_{SS}		40		0.01	40		300	μA
		$V_{DD} = 15V, V_{IN} = V_{DD}$ or V_{SS}		80		0.02	80		600	μA
V_{OL}	Low Level Output Voltage	$ I_O \leq 1 \mu A, V_{IL} = 0V, V_{IH} = V_{DD}$								
		$V_{DD} = 5.0V$		0.05		0	0.05		0.05	V
		$V_{DD} = 10V$		0.05		0	0.05		0.05	V
		$V_{DD} = 15V$		0.05		0	0.05		0.05	V
V_{OH}	High Level Output Voltage	$ I_O \leq 1 \mu A, V_{IL} = 0V, V_{IH} = V_{DD}$								
		$V_{DD} = 5.0V$	4.95		4.95	5.0		4.95		V
		$V_{DD} = 10V$	9.95		9.95	10		9.95		V
		$V_{DD} = 15V$	14.95		14.95	15		14.95		V

DC Electrical Characteristics CD4043BC/CD4044BC (Continued)

Symbol	Parameter	Conditions	-40°C		+25°C			+85°C		Units
			Min	Max	Min	Typ	Max	Min	Max	
V _{IL}	Low Level Input Voltage	I _O ≤ 1 μA V _{DD} = 5.0V, V _O = 0.5V or 4.5V V _{DD} = 10V, V _O = 1.0V or 9.0V V _{DD} = 15V, V _O = 1.5V or 13.5V		1.5		2.25	1.5		1.5	V
				3.0		4.5	3.0		3.0	V
				4.0		6.75	4.0		4.0	V
V _{IH}	High Level Input Voltage	I _O ≤ 1 μA V _{DD} = 5.0V, V _O = 0.5V or 4.5V V _{DD} = 5.0V, V _O = 1.0V or 9.0V V _{DD} = 15V, V _O = 1.5V or 13.5V	3.5		3.5			3.5		V
			7.0		7.0			7.0		V
			11		11			11		V
I _{OL}	Low Level Output Current (Note 3)	V _{IL} = 0V, V _{IH} = V _{DD} V _{DD} = 5.0V, V _O = 0.4V V _{DD} = 10V, V _O = 0.5V V _{DD} = 15V, V _O = 1.5V	0.52		0.44	0.88		0.36		mA
			1.3		1.1	2.2		0.9		mA
			3.6		3.0	6.0		2.4		mA
I _{OH}	High Level Output Current (Note 3)	V _{IL} = 0V, V _{IH} = V _{DD} V _{DD} = 5.0V, V _O = 4.6V V _{DD} = 10V, V _O = 9.5V V _{DD} = 15V, V _O = 13.5V	-0.52		-0.44	-0.32		-0.36		mA
			-1.3		-1.1	-0.8		-0.9		mA
			-3.6		-3.0	-2.4		-2.4		mA
I _{IN}	Input Current	V _{DD} = 15V, V _{IN} = 0V V _{DD} = 15V, V _{IN} = 15V	-0.3			-0.3			-1.0	μA
			0.3			0.3			1.0	μA

AC Electrical Characteristics*

T_A = 25°C, C_L = 50 pF, R_L = 200k, input t_r = t_f = 20 ns, unless otherwise noted

Symbol	Parameter	Conditions	Min	Typ	Max	Units
t _{PLH} , t _{PHL}	Propagation Delay S or R to Q	V _{DD} = 5.0V		175	350	ns
		V _{DD} = 10V		75	175	ns
		V _{DD} = 15V		60	120	ns
t _{PZH} , t _{PHZ}	Propagation Delay Enable to Q (High)	V _{DD} = 5.0V		115	230	ns
		V _{DD} = 10V		55	110	ns
		V _{DD} = 15V		40	80	ns
t _{PZL} , t _{PLZ}	Propagation Delay Enable to Q (Low)	V _{DD} = 5.0V		100	200	ns
		V _{DD} = 10V		50	100	ns
		V _{DD} = 15V		40	80	ns
t _{THL} , t _{TLH}	Transition Time	V _{DD} = 5.0V		100	200	ns
		V _{DD} = 10V		50	100	ns
		V _{DD} = 15V		40	80	ns
t _{WO}	Minimum SET or RESET Pulse Width	V _{DD} = 5.0V		80	160	ns
		V _{DD} = 10V		40	80	ns
		V _{DD} = 15V		20	40	ns
C _{IN}	Input Capacitance			5.0	7.5	pF

*AC Parameters are guaranteed by DC correlated testing.

Note 1: "Absolute Maximum Ratings" are those values beyond which the safety of the device cannot be guaranteed; they are not meant to imply that the devices should be operated at these limits. The tables of "Recommended Operating Conditions" and "Electrical Characteristics" provide conditions for actual device operation.

Note 2: V_{SS} = 0V unless otherwise specified.

Note 3: I_{OH} and I_{OL} are tested one output at a time.

Schematic Diagrams

CD4043BM/CD4043BC

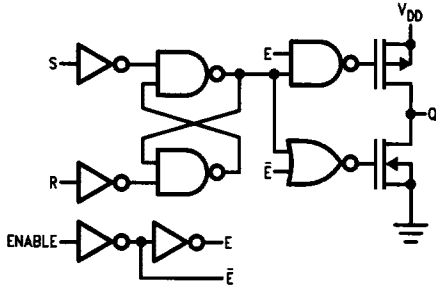

TL/F/5967-1

CD4044BM/CD4044BC

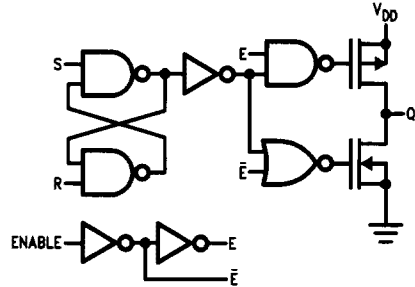

TL/F/5967-2

Timing Waveforms

CD4043B

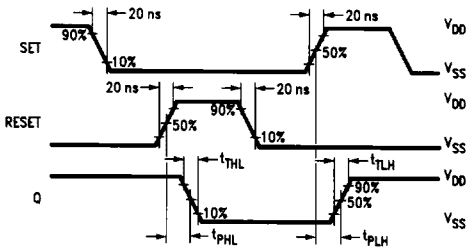

TL/F/5967-5

CD4044B

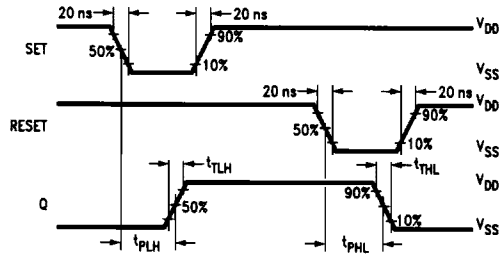

TL/F/5967-6

Enable Timing

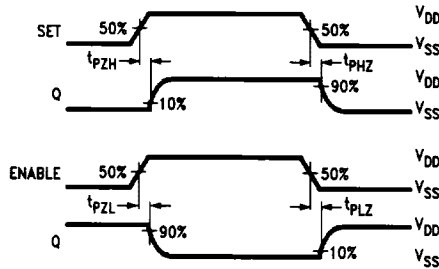

TL/F/5967-7