

# ITE35F12/ITE35C12

## POWERLINE N-CHANNEL IGBT WITH OPTIONAL ULTRAFAST DIODE

The ITE35X12 is a robust n-channel, enhancement mode insulated gate bipolar transistor (IGBT) designed for low power dissipation in a wide range of high voltage applications such as power supplies and motor drives. The high impedance gate simplifies gate drive considerations, allowing operation directly from low power control circuitry.

Fast rise and fall times allow very high frequency switching making the device suitable for modern systems employing ultrasonic switching.

Low saturation voltages minimise power dissipation, thereby reducing the cost of the overall system in which they are used.

Each device in the Powerline range is available with or without an integral anti-parallel ultrafast soft recovery diode, see Ordering Information.

Typical applications include high frequency inverters for motor control, welding and heating apparatus. The Powerline range of IGBTs is also applicable to switched mode and uninterruptible power supplies.

### FEATURES

- Enhancement Mode n-Channel Device
- High Switching Speed
- Low On-state Saturation Voltage
- High Input Impedance Simplifies Gate Drive
- Latch-Free Operation
- Optionally Available With Integral Fast Recovery Diode

### APPLICATIONS

- High Frequency Inverters
- Motor Control
- Switched Mode Power Supplies
- High Frequency Welding
- Heating/Cooking Apparatus

### ORDERING INFORMATION

ITE35C12 (TO218 With fast recovery diode)  
ITE35F12 (TO247 Without fast recovery diode)

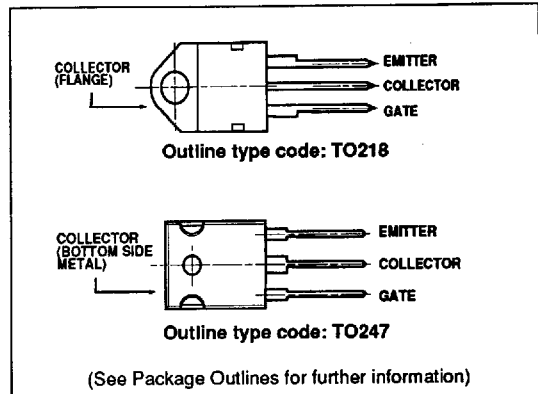

Fig. 1 Pin connections - top view (not to scale)

### IGBT KEY PARAMETERS

$V_{CES}$	1200V
$V_{CE(sat)}$	3.0V
$I_{C(CONT)}$	35A
$I_{C(PK)}$	70A
$t_r$	300ns
$t_f$	400ns

### DIODE KEY PARAMETERS

$V_{RRM}$	1200V
$I_F$	35A
$t_{rr}$	100ns

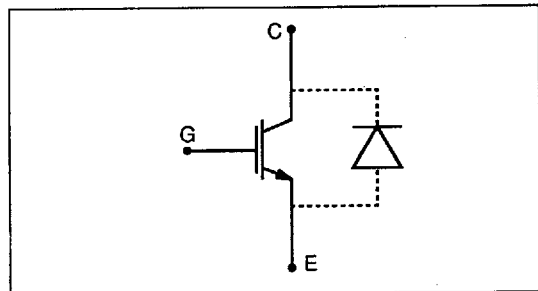

Fig. 2 ITE35X12 circuit

## IGBT ABSOLUTE MAXIMUM RATINGS

Stresses above those listed under 'Absolute Maximum Ratings' may cause permanent damage to the device. This is a stress rating only and functional operation of the device at these or any other conditions above those indicated in the operational sections of this specification is not implied. Exposure to Absolute Maximum Ratings for extended periods may affect device reliability.

$T_{\text{case}} = 25^{\circ}\text{C}$  unless stated otherwise.

Symbol	Parameter	Test Conditions	Max.	Units
$V_{\text{CES}}$	Collector-emitter voltage	$V_{\text{GE}} = 0\text{V}$	1200	V
$V_{\text{GES}}$	Gate-emitter voltage	-	$\pm 20$	V
$I_{\text{C}}$	Collector current	DC, $T_{\text{case}} = 85^{\circ}\text{C}$	35	A
$I_{\text{CM}}$		1ms, $T_{\text{case}} = 85^{\circ}\text{C}$	70	A
$P_{\text{tot}}$	Power dissipation	$T_{\text{case}} = 85^{\circ}\text{C}$	150	W

## THERMAL AND MECHANICAL RATINGS

Symbol	Parameter	Conditions	Min.	Max.	Units
$R_{\text{th(j-c) IGBT}}$	Thermal resistance - IGBT	DC junction to case	-	0.42	$^{\circ}\text{C/W}$
$R_{\text{th(j-c) DIODE}}$	Thermal resistance - Diode	DC junction to case	-	0.7	$^{\circ}\text{C/W}$
$T_{\text{j}}$	Junction temperature (IGBT/Diode)	-	-40	150	$^{\circ}\text{C}$
$T_{\text{op}}/T_{\text{stg}}$	Operating and storage temp. range (IGBT/Diode)	-	-40	150	$^{\circ}\text{C}$

## IGBT DC ELECTRICAL CHARACTERISTICS

$T_{\text{case}} = 25^{\circ}\text{C}$  unless stated otherwise.

Symbol	Parameter	Conditions	Min.	Typ.	Max.	Units
$I_{\text{CES}}$	Collector cut-off current	$V_{\text{GE}} = 0\text{V}$ , $V_{\text{CE}} = 1200\text{V}$	-	-	1	mA
$I_{\text{GES}}$	Gate leakage current	$V_{\text{GE}} = 15\text{V}$ , $V_{\text{CE}} = 0\text{V}$	-	-	500	nA
$V_{\text{GE(TH)}}$	Gate threshold voltage	$I_{\text{C}} = 2\text{mA}$ , $V_{\text{GE}} = V_{\text{CE}}$	3.0	4.5	6.0	V
$V_{\text{CE(SAT)}}$	Collector-emitter saturation voltage	$V_{\text{GE}} = 15\text{V}$ , $I_{\text{C}} = 35\text{A}$	-	2.5	3.0	V

# ITE35X12

## IGBT AC ELECTRICAL CHARACTERISTICS

$T_{case} = 25^{\circ}\text{C}$  unless stated otherwise.

Symbol	Parameter	Conditions	Min.	Typ.	Max.	Units
$C_{ies}$	Input capacitance	$V_{CE} = 35\text{V}, V_{GE} = 15\text{V}, f = 1\text{MHz}$	-	4900	-	pF
$C_{oes}$	Output capacitance	$V_{CE} = 35\text{V}, V_{GE} = 15\text{V}, f = 1\text{MHz}$	-	1200	-	pF
$C_{res}$	Reverse transfer capacitance	$V_{CE} = 35\text{V}, V_{GE} = 15\text{V}, f = 1\text{MHz}$	-	1150	-	pF

## IGBT RESISTIVE SWITCHING CHARACTERISTICS

$T_{case} = 25^{\circ}\text{C}$  unless stated otherwise.

Symbol	Parameter	Conditions	Min.	Typ.	Max.	Units
$t_{(ON)}$	Turn-on delay time	$I_C = 35\text{A},$ $V_{GE} = \pm 15\text{V},$ $V_{CE} = 50\% V_{CES}$ $R_{G(ON)} = R_{G(OFF)} = 2.7\Omega$	-	200	-	ns
$t_r$	Rise time		-	300	-	ns
$E_{ON}$	Turn-on energy loss - per cycle		-	2.5	-	mWs
$t_{(OFF)}$	Turn-off delay time		-	520	-	ns
$t_f$	Fall time		-	500	-	ns
$E_{OFF}$	Turn-off energy loss - per cycle		-	3.4	-	mWs

## IGBT INDUCTIVE SWITCHING CHARACTERISTICS

$T_{case} = 25^{\circ}\text{C}$  unless stated otherwise.

Symbol	Parameter	Conditions	Min.	Typ.	Max.	Units
$t_{(off)}$	Turn-off delay time	$I_C = 35\text{A}, V_{GE} = \pm 15\text{V}$ $V_{CE} = 50\% V_{CES}$ $R_{G(ON)} = R_{G(OFF)} = 2.7\Omega$	-	520	-	ns
$t_f$	Fall time		-	400	-	ns
$E_{OFF}$	Turn-off energy loss - per cycle		-	3.4	-	mWs

**DIODE ABSOLUTE MAXIMUM RATINGS**

Stresses above those listed under 'Absolute Maximum Ratings' may cause permanent damage to the device. This is a stress rating only and functional operation of the device at these or any other conditions above those indicated in the operational sections of this specification is not implied. Exposure to Absolute Maximum Ratings for extended periods may affect device reliability.

Symbol	Parameter	Conditions	Max.	Units
$V_{RRM}$	Repetitive peak reverse voltage	$T_{case} = 150^{\circ}C$	1200	V
$I_F$	Forward current	Half wave resistive load, $T_{case} = 85^{\circ}C$	35	A

**DIODE CHARACTERISTICS**

$T_{case} = 25^{\circ}C$  unless stated otherwise.

Symbol	Parameter	Conditions	Min.	Typ.	Max.	Units
$V_{FM}$	Forward voltage	At $I_F = 35A$ peak	-	-	2.2	V
$I_{RM}$	Peak reverse current	At $V_{RRM}$ , $T_{case} = 125^{\circ}C$	-	-	5.0	mA
$t_{rr}$	Reverse recovery time	$I_F = 35A$ , $di_{RR}/dt = 200A/\mu s$	-	100	-	ns
$I_{RRM}$	Reverse recovery current	$V_R = 50\%V_{RRM}$	-	18	-	A

MEASUREMENT OF SWITCHING TIMES AND POWER DISSIPATION

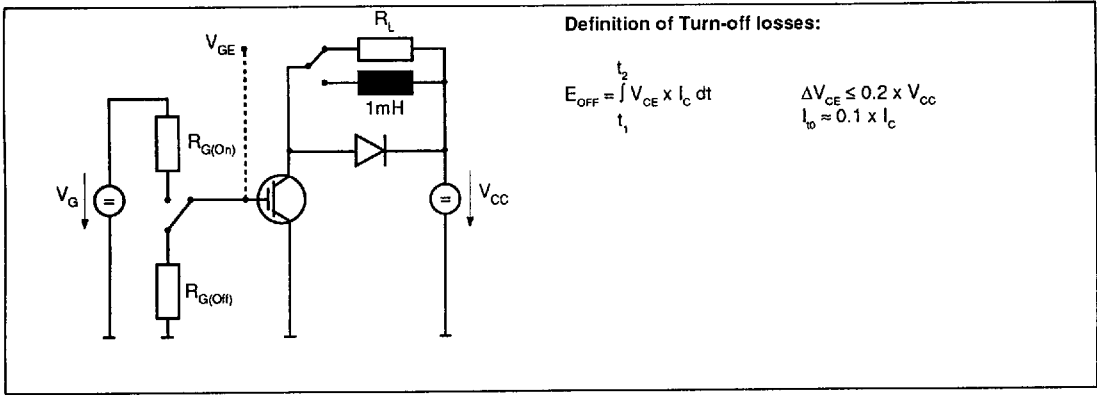

Fig.3 Test circuit

DEFINITION OF SWITCHING TIMES

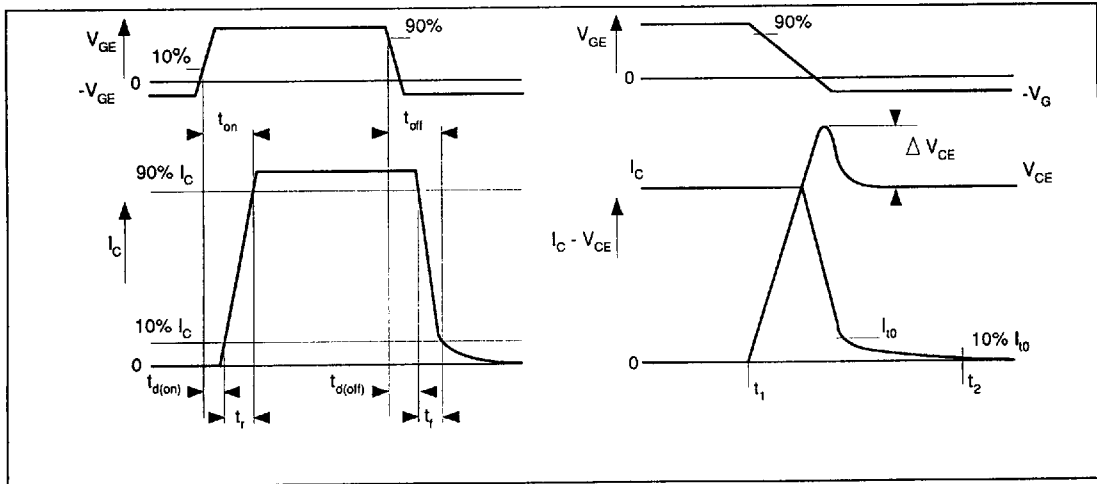

Fig.4 Definition of switching times

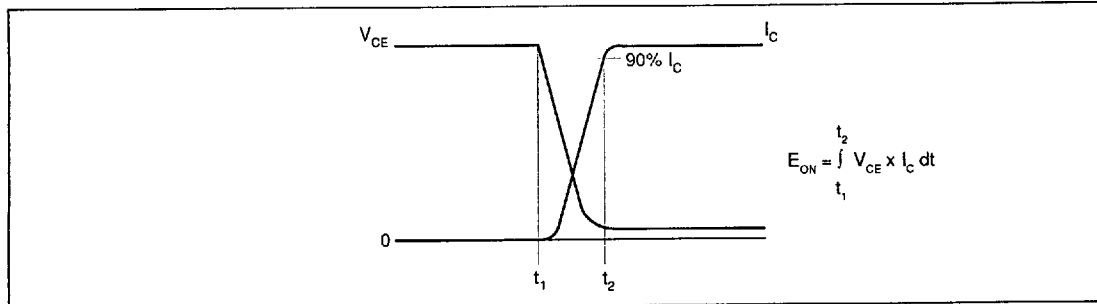

Fig.5 Definition of turn on losses

## CURVES

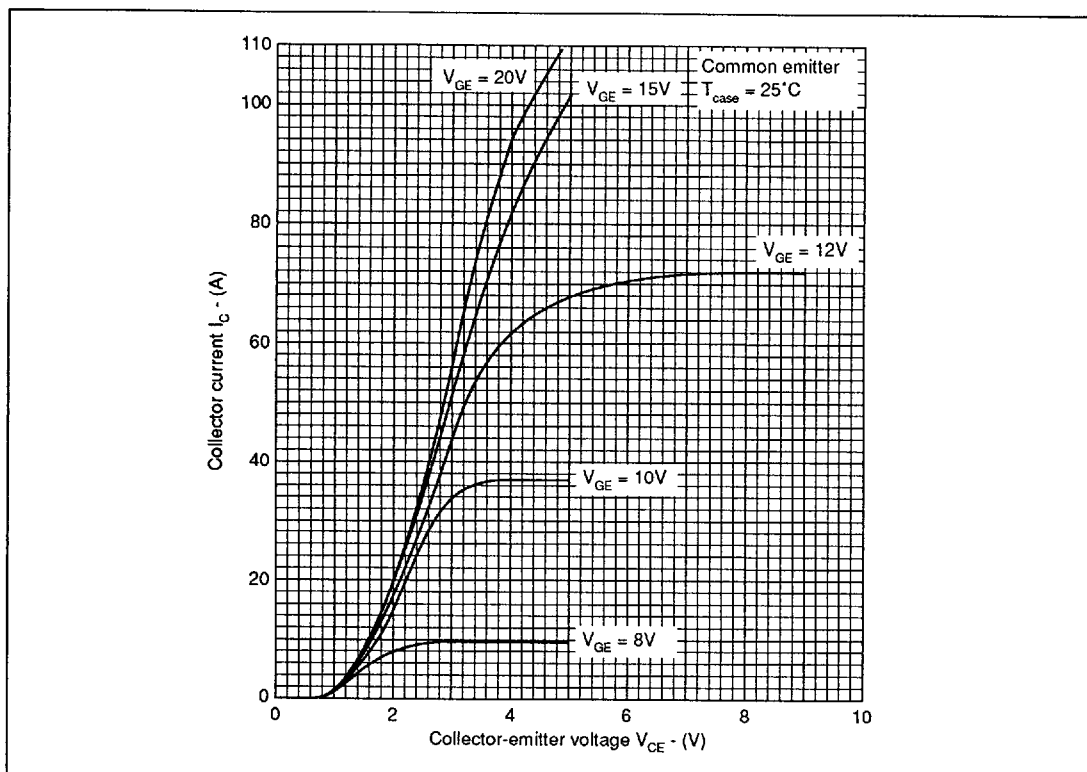

Fig.6 Typical output characteristics

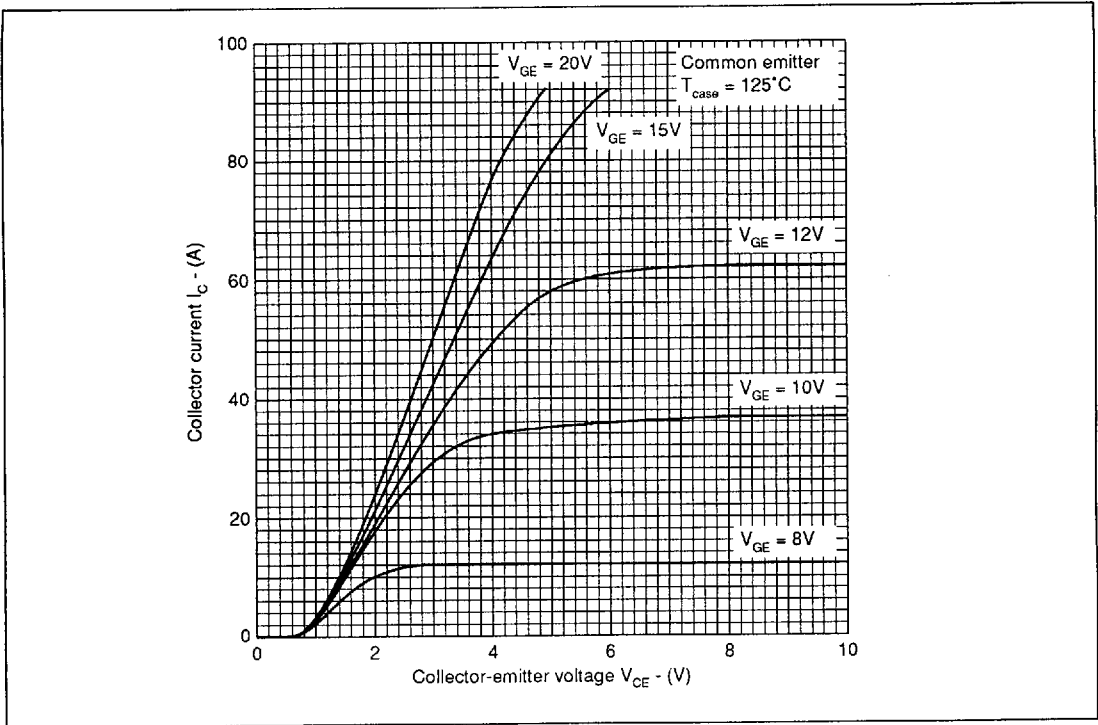

Fig.7 Typical output characteristics

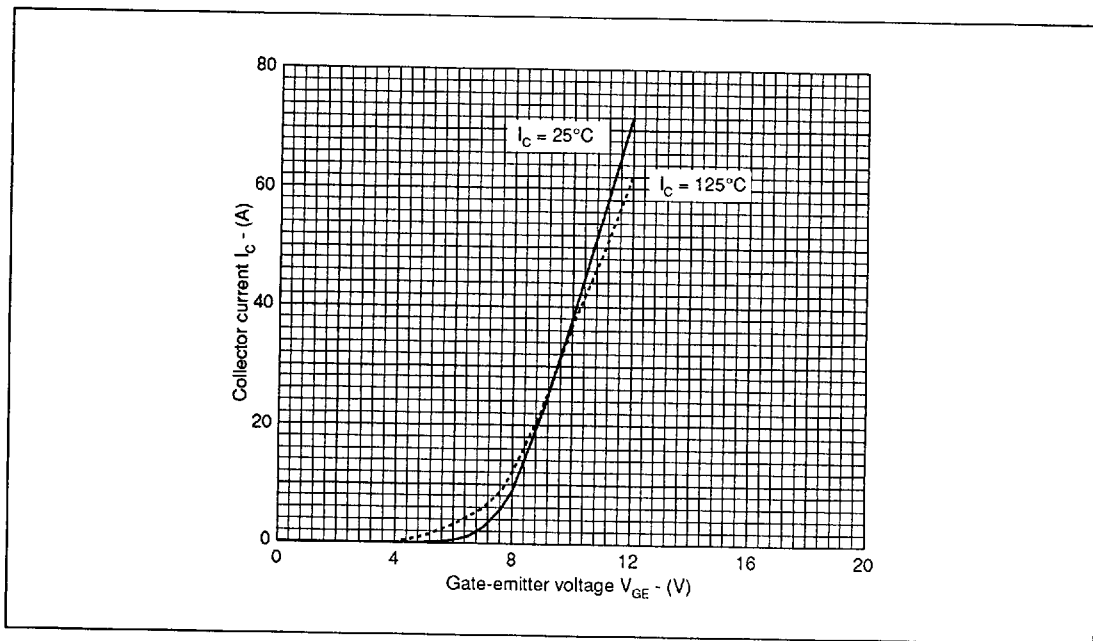

Fig.8 Typical on-state characteristics

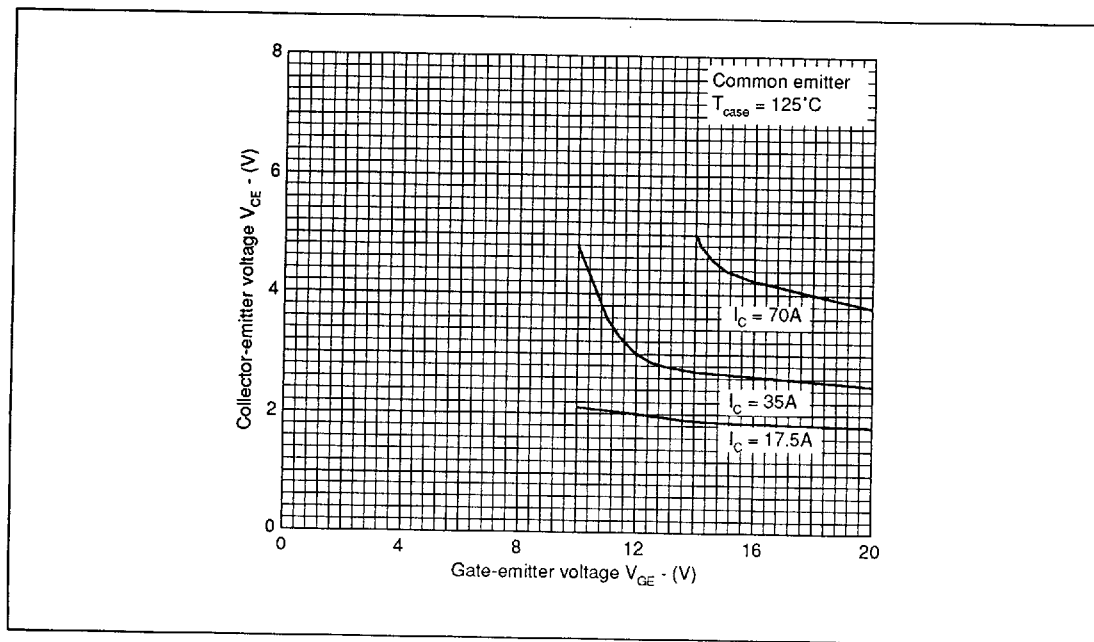

Fig.9 Typical on-state characteristics

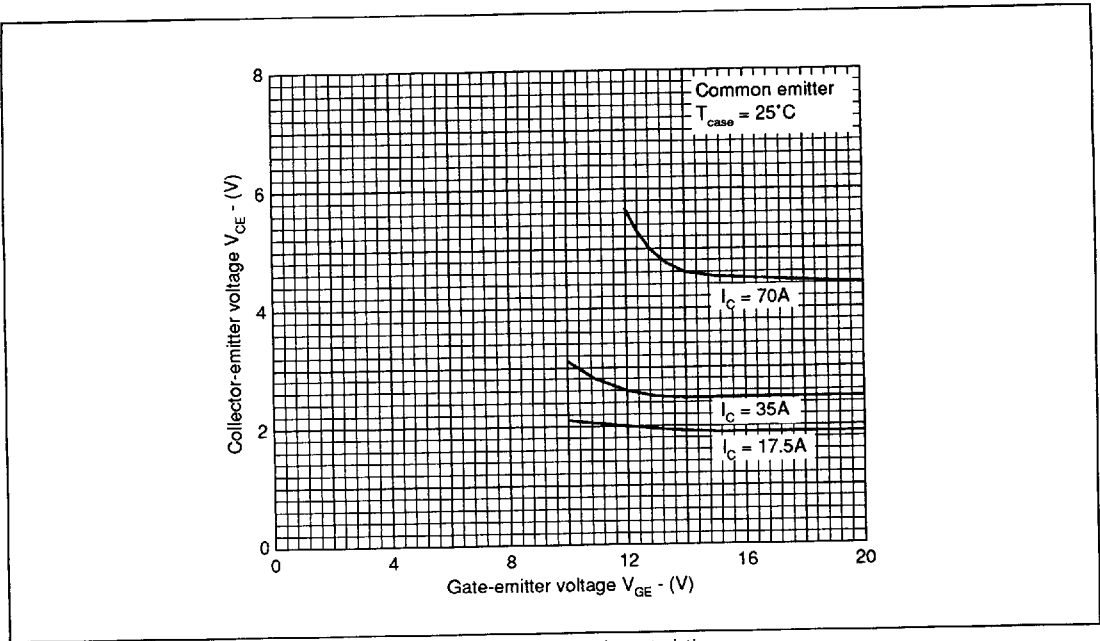

Fig. 10 Typical on-state characteristics

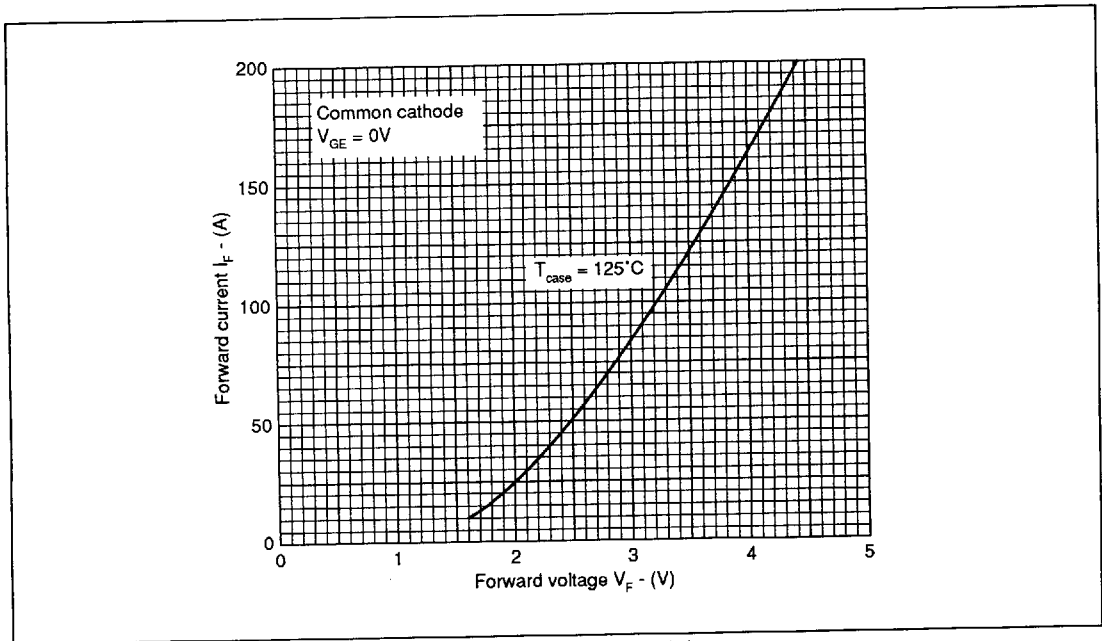

Fig. 11 Diode forward characteristics

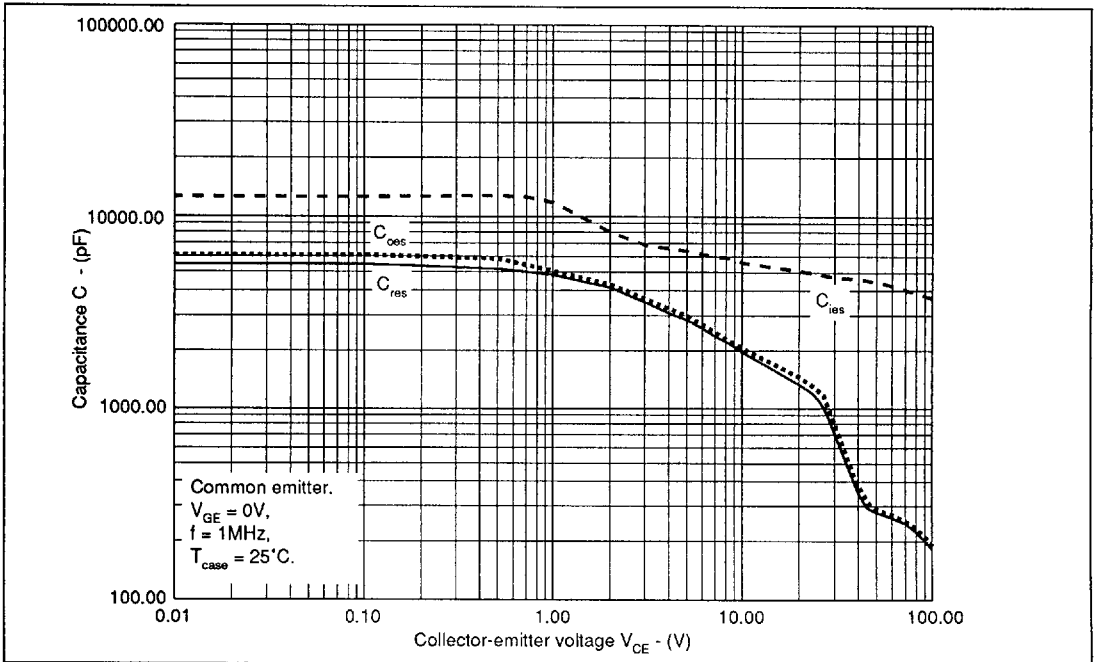

Fig.12 Typical capacitance

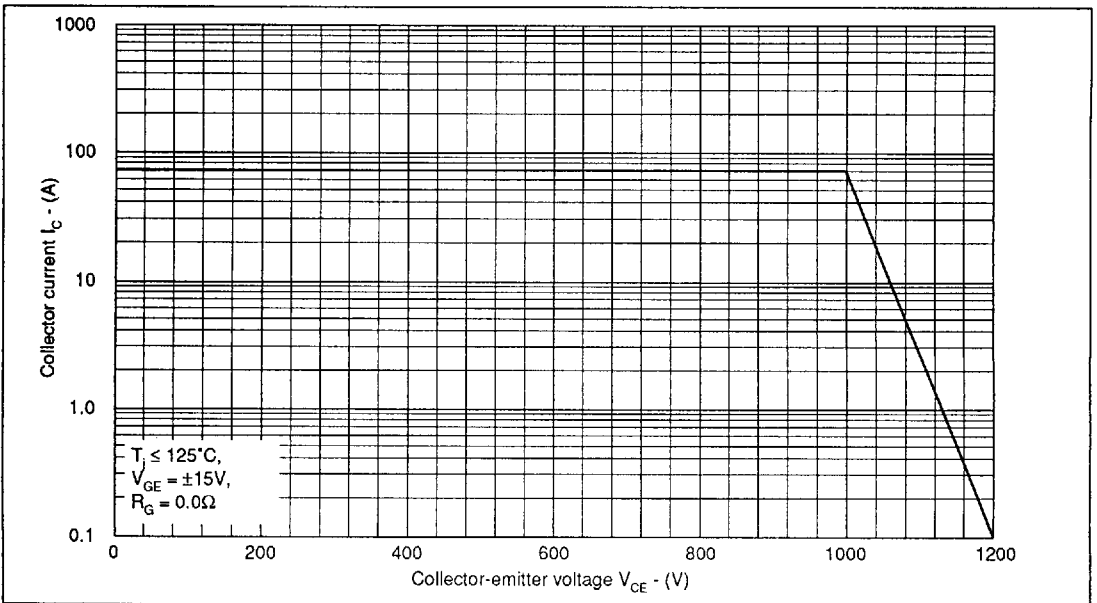

Fig.13 Reverse bias safe operating area