

SMA33NP-0141	SMA Plug Solder For RG402 27GHz VSWR 1.2	<b>50Ω</b>																					
																							
<table border="1" style="width: 100%; border-collapse: collapse; text-align: center;"> <thead> <tr> <th style="width: 20%;">Parts</th> <th style="width: 20%;">Material</th> <th style="width: 60%;">Plating (Micro-inch)</th> </tr> </thead> <tbody> <tr> <td>Contact Pin</td> <td>Brass</td> <td>Gold 4 Over Nickel-Phosphorus Alloy 80 Over Copper 20</td> </tr> <tr> <td>Renber Ring</td> <td>Beryllium Copper</td> <td>Tin-Zinc-Copper-Alloy 100 Over Copper 50</td> </tr> <tr> <td>Gasket</td> <td>Silicon</td> <td></td> </tr> <tr> <td>Insulator</td> <td>Teflon</td> <td></td> </tr> <tr> <td>Body</td> <td>Brass</td> <td>Gold 4 Over Nickel-Phosphorus Alloy 80 Over Copper 20</td> </tr> <tr> <td>Coupling Nut</td> <td>stainless</td> <td>Passivated</td> </tr> </tbody> </table>			Parts	Material	Plating (Micro-inch)	Contact Pin	Brass	Gold 4 Over Nickel-Phosphorus Alloy 80 Over Copper 20	Renber Ring	Beryllium Copper	Tin-Zinc-Copper-Alloy 100 Over Copper 50	Gasket	Silicon		Insulator	Teflon		Body	Brass	Gold 4 Over Nickel-Phosphorus Alloy 80 Over Copper 20	Coupling Nut	stainless	Passivated
Parts	Material	Plating (Micro-inch)																					
Contact Pin	Brass	Gold 4 Over Nickel-Phosphorus Alloy 80 Over Copper 20																					
Renber Ring	Beryllium Copper	Tin-Zinc-Copper-Alloy 100 Over Copper 50																					
Gasket	Silicon																						
Insulator	Teflon																						
Body	Brass	Gold 4 Over Nickel-Phosphorus Alloy 80 Over Copper 20																					
Coupling Nut	stainless	Passivated																					
Weight: 2.26 g Suitable Cables: Semi-rigid.141; Formable 0141; RG402																							

**This part number complies with RoHS.**

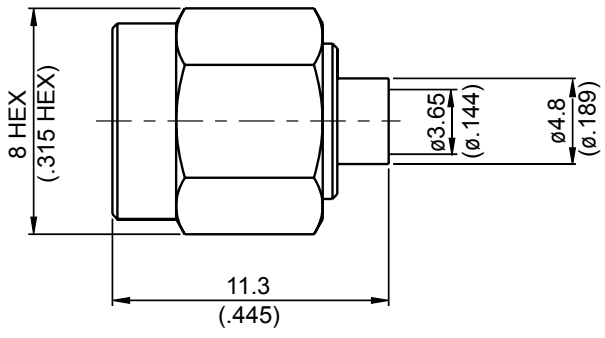

**Notice: JYEBAO reserves the right to make modifications deemed appropriate.**

SMA	SMA33NP-0141
<b>Interface</b>	
MIL-STD-348B	
Mechanically compatible with	2.92 & 3.5
<b>Electrical Data</b>	
Impedance	50Ω
Frequency range	DC to 27GHz
VSWR	≤ 1.2 (DC to 27GHz)
Insertion loss	≤ 0.04 x √f(GHz) dB
Insulation resistance	≥ 5000MΩ
Contact resistance inner conductor	≤ 3mΩ
Contact resistance outer conductor	≤ 2mΩ
Dielectric withstanding voltage (at sea level)	1500 V rms
Working voltage (at sea level)	500 V rms
<b>Mechanical Data</b>	
Recommended coupling nut torque	7 to 9.5 inch lbs
Coupling proof torque	15 inch lbs
Coupling nut retention force	≥ 60.7 lbs
Contact Captivation-axial	≥ 6.1 lbs
Durability (mating)	≥ 500
<b>Environmental Data</b>	
Temperature range	-65°C to +165°C
Thermal shock	MIL-STD-202, Method 107, Condition B
Moisture resistance	MIL-STD-202, Method 106
Corrosion	MIL-STD-202, Method 101, Condition B
RoHS	Compliant
<b>Tooling</b>	
Soldering fixture	ST-008
Insert for .141 inch semi-rigid cable	ST-010
Locator tool	ST-011
Dielectric insertion tool	ST-003
Soldering gauge	ST-0.3

Notice: JYEBAO reserves the right to make modifications deemed appropriate.

# JYE BAO CO., LTD.

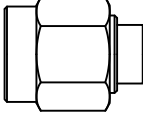
## CABLE ASSEMBLY INSTRUCTION

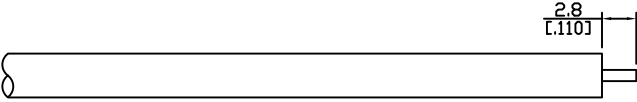
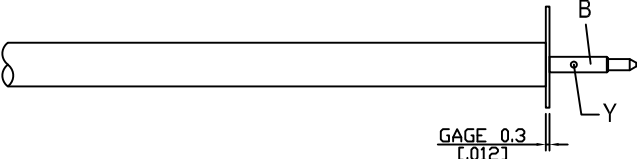
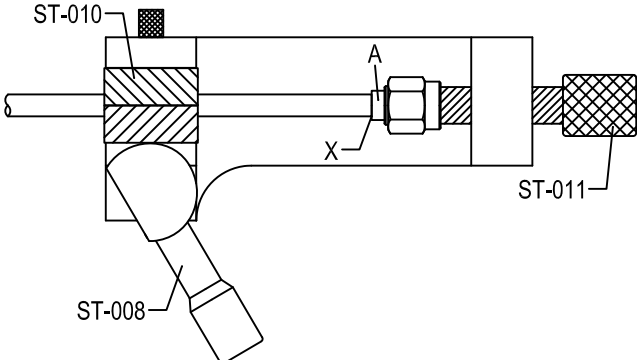
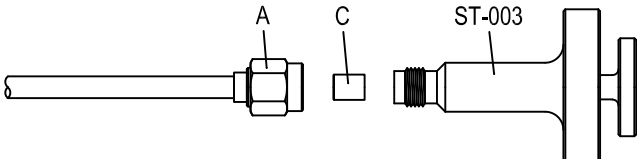
SMA33NP-0141	DATE	2017/12/01	REV	—
A	B	C		
				
BODY	CONTACT PIN	INSULATOR		
DIAGRAM	ASSEMBLY INSTRUCTION			
	Step 1: STRIP AS SHOWN.			
	Step 2: PUT PIN " B " ON CENTER CONDUCTOR AND SOLDER IN " Y ". USE 0.3MM GAGE ST-0.3			
	Step 3: USE SOLDERING FIXTURE " ST-008 ", INSERT TOOL " ST-010 " AND LOCATOR TOOL " ST-011 " TO FIX THE CONNECTOR. SOLDER IN " X ".			
	Step 4: USE DIELECTRIC INSERTION TOOL " ST-003 " TO INSERT THE TEFLON " C ".			
<p>This part number complies with RoHS.</p> <p>Notice: JYEBAO reserves the right to make modifications deemed appropriate.</p>				
APPROVED	CHECKED	DRAWING	<i>Albert</i>	

# SMA33NP-0141

