

Am54S/74S399

Quad Two-Input, High-Speed Register

Distinctive Characteristics

- Four-bit register accepts data from one of two 4-bit input fields
- Edge triggered clock action
- High-speed Schottky technology
- 100% reliability assurance testing in compliance with MIL-STD-883

FUNCTIONAL DESCRIPTION

The Am54S/74S399 is a dual port high-speed, four-bit register using advanced Schottky technology to reduce the effect of transistor storage time. The register consists of four D flip-flops with a buffered common clock, and a two-input multiplexer at the input of each flip-flop. A common select line, S, controls the four multiplexers. Data on the four inputs selected by the S line is stored in the four flip-flops at the clock LOW-to-HIGH transition. When the S input is LOW, the D_{iA} input data will be stored in the register. When the S input is HIGH, the D_{iB} input data will be stored in the register.

LOGIC SYMBOL

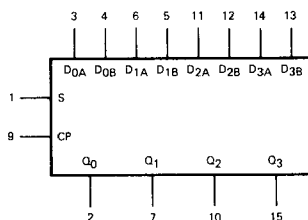

V_{CC} = Pin 16
GND = Pin 8

LOGIC DIAGRAM

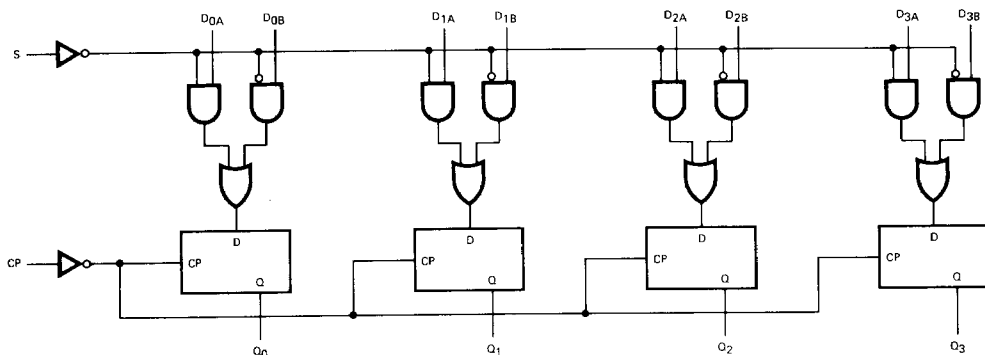

CONNECTION DIAGRAM Top View

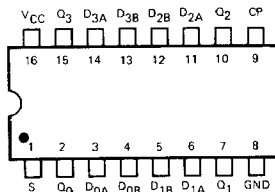

Note: Pin 1 is marked for orientation.

MAXIMUM RATINGS (Above which the useful life may be impaired)

Storage Temperature	-65°C to +150°C
Temperature (Ambient) Under Bias	-55°C to +125°C
Supply Voltage to Ground Potential (Pin 16 to Pin 8) Continuous	-0.5 V to +7 V
DC Voltage Applied to Outputs for High Output State	-0.5 V to +V _{CC} max.
DC Input Voltage	-0.5 V to +5.5 V
DC Output Current, Into Outputs	30 mA
DC Input Current	-30 mA to +5.0 mA

ELECTRICAL CHARACTERISTICS OVER OPERATING TEMPERATURE RANGE (Unless Otherwise Noted)

SN74S399	T _A = 0°C to +70°C	V _{CC} = 5.0V ± 5% (COM'L)	MIN. = 4.75V	MAX. = 5.25V
SN54S399	T _A = -55°C to +125°C	V _{CC} = 5.0V ± 10% (MIL)	MIN. = 4.5V	MAX. = 5.5V

Parameters	Description	Test Conditions (Note 1)	Min.	Typ. (Note 2)	Max.	Units
V _{OH}	Output HIGH Voltage	V _{CC} = MIN., I _{OH} = -1.0mA V _{IN} = V _{IH} or V _{IL}	COM'L MIL	2.7 2.5	3.4 3.4	Volts
V _{OL}	Output LOW Voltage	V _{CC} = MIN., I _{OL} = 20.0mA V _{IN} = V _{IH} or V _{IL}		0.3	0.5	Volts
V _{IH}	Input HIGH Level	Guaranteed input logical HIGH voltage for all inputs	2.0			Volts
V _{IL}	Input LOW Level	Guaranteed input logical LOW voltage for all inputs			0.8	Volts
V _I	Input Clamp Voltage	V _{CC} = MIN., I _I = -18mA			-1.2	Volts
I _{IL}	Unit Load Input LOW Current	V _{CC} = MAX., V _{IN} = 0.5V			-2.0	mA
I _{IH}	Unit Load Input HIGH Current	V _{CC} = MAX., V _{IN} = 2.7V			50	μA
I _I	Input HIGH Current	V _{CC} = MAX., V _{IN} = 5.5V			1.0	mA
I _{SC}	Output Short Circuit Current (Note 3)	V _{CC} = MAX.	-40		-100	mA
I _{CC}	Power Supply Current	V _{CC} = MAX. (Note 4)		75	120	mA

- Notes: 1. For conditions shown as MIN. or MAX., use the appropriate value specified under Electrical Characteristics for the applicable device type.
 2. Typical limits are at V_{CC} = 5.0V, 25°C ambient and maximum loading.
 3. Not more than one output should be shorted at a time. Duration of the short circuit test should not exceed one second.
 4. Measured with Select and Clock inputs at 4.5V; all data inputs at 0V; all outputs open.

Switching Characteristics (T_A = +25°C)

Parameters	Description	Test Conditions	Min.	Typ.	Max.	Units
t _{PLH}	Clock to Q HIGH	V _{CC} = 5.0V, C _L = 15pF, R _L = 280Ω		8	12	ns
t _{PHL}	Clock to Q LOW			11.5	17	ns
t _{pw}	Clock Pulse Width			7		ns
t _s	Data Set-up Time			5.5		ns
t _s	Select Input Set-up Time			10		ns
t _h	Data Hold Time			3		ns
t _h	Select Input Hold Time			3		ns