

DIO5310

39V Step-Up LED Driver with One-Wire Dimming

Features

- Drive up to 10 serial LEDs
- 32 levels One-Wire dimming
- Integrated 40V high current switch (1.65A limit)
- Wide V_{IN} Input Range: 2.7V~5.5V
- Low 200mV feedback voltage
- LED open-circuit (OVP) protection@39V
- High switching frequency@850KHz
- For Compact Solution Size
- Integrated Softstart
- $0.1 \mu A$ shutdown current
- RoHS and Green compliant
- -40 to +85 °C Temperature range

Applications

- LED backlighting
- Mobile Phones
- Handheld Devices
- Digital Photo Frames
- Automotive Navigation

Descriptions

DIO5310 is a serial white LED driver, driving up to 10 serial LEDs or a 3x13(3 LEDs in rows) LED matrix. And it adopts 32 levels one-wire dimming. The serial configuration assures the very most brightness consistency of the whole LED array. DIO5310 works on 850KHz switching frequency, which can maximize current output of 1.65A limit and achieve high current conversion efficiency and result in external compact component size. Additionally, the total external component number is minimized due to the integrated low-side power MOSFET.

DIO5310 integrates multiple protection features, such as LED open-circuit protection, thermal shutdown protection and cycle-by-cycle input current limit protection. And the built-in soft start circuit limits inrush current when the circuit starts.

DIO5310 provides with RoHS compliant SOT23-6, and DFN-6 package.

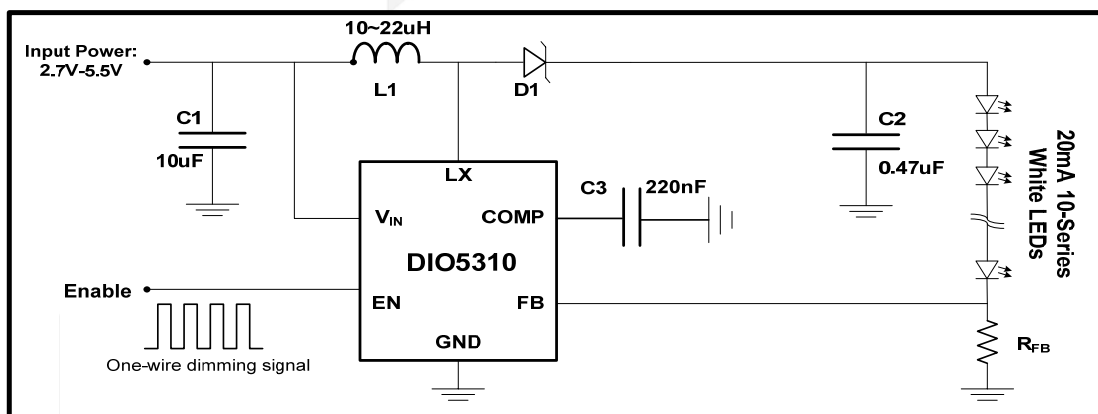

Ordering Information

Order Part Number	Top Marking		T_A	Package	
DIO5310CST6	YW(X)Z	RoHS or Green	-40 to +85°C	SOT23-6	Tape & Reel, 3000
DIO5310CD6	5310	RoHS or Green	-40 to +85°C	DFN-6	Tape & Reel, 3000

Pin Assignment

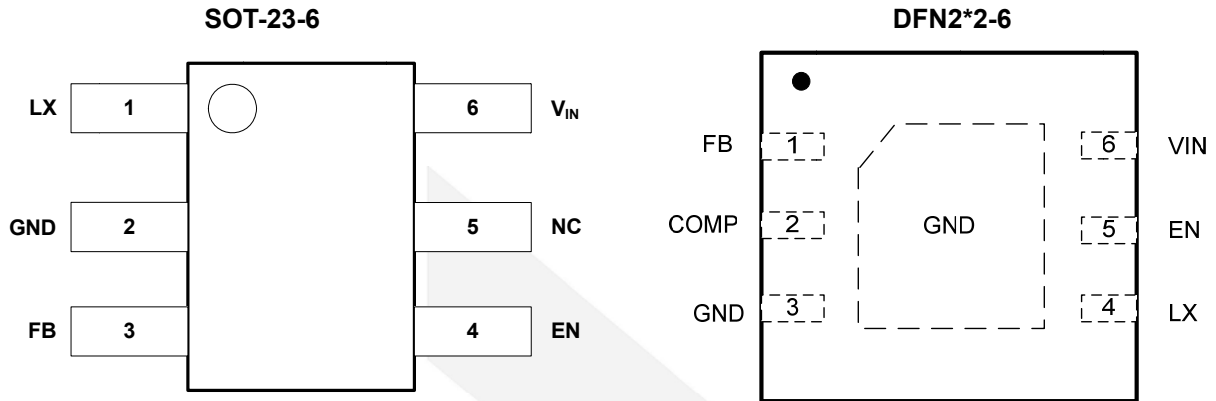

Figure 1 Top View

Pin Descriptions

Name	Description
LX	Converter switching node
GND	Converter/IC ground
FB	Output feedback voltage pin, 200mV typ
EN	IC enable and one-wire dimming control pin
COMP	Output of the trans conductance error amplifier. Connect an external capacitor to this pin to compensate the regulator.
NC	Not Connect.
V _{IN}	IC supply voltage



DIO5310

39V Step-Up LED Driver with One-Wire Dimming

Absolute Maximum Ratings

Stresses beyond those listed under "Absolute Maximum Rating" may cause permanent damage to the device. These are stress ratings only and functional operation of the device at these or any other condition beyond those indicated in the operational sections of the specifications is not implied. Exposure to absolute maximum rating conditions for extended periods may affect device reliability.

Parameter	Rating	Unit
Supply Voltage / V_{IN}	-0.3 to 6.0	V
High Voltage Nodes / LX	-0.3 to 44	V
Other pins / FB, EN	-0.3 to $V_{IN} + 0.3$	V
Operating Temperature Range / T_J	-40 to 150	°C
Storage Temperature Range / T_S	-65 to 150	°C
Lead Temperature Range / T_{LEAD}	300	°C
Thermal Resistance / θ_{JA}	190	°C/W
Maximum Power Dissipation at $T_A < 25^\circ\text{C}$	0.526	W
ESD CDM, JEDEC: JESD22-C101	4	kV

Recommend Operating Conditions

The Recommended Operating Conditions table defines the conditions for actual device operation. Recommended Operating conditions are specified to ensure optimal performance to the datasheet specifications. DIOO does not Recommend exceeding them or designing to Absolute Maximum Ratings.

Parameter	Rating	Unit
Supply Voltage	2.7 to 5.5	V
Operating Temperature Range	-40 to 85	°C



DIO5310

39V Step-Up LED Driver with One-Wire Dimming

Electrical Characteristics

Typical value: $V_{CC}=3.6V$, $T_A = 25^{\circ}C$, unless otherwise specified.

Symbol	Parameter	Conditions	Min.	Typ.	Max.	Unit
DC Character						
V_{IN}	Input operating range		2.7		5.5	V
UVLO	Input under voltage lockout	Rising edge		2.5	2.7	V
UVLO _{HYST}	UVLO hysteresis			0.2		V
I_Q	IC quiescent current(non switching)	FB=0.4V		0.33		mA
	IC quiescent current (switching)	FB=0V		0.85		mA
I_{SHDN}	V_{IN} pin shutdown current	EN=GND		0.01	0.1	μA
Boost Converter						
FB	FB pin accuracy		0.192	0.2	0.208	V
I_{FB}	FB pin bias current			0.1		μA
$R_{DS(ON)}$	NMOS on-resistance			0.6		Ω
I_{LX}	LX pin leakage current			0.1		μA
I_{LIM}	Peak NMOS current limit			1.65		A
F_{SW}	Oscillator frequency			850		KHz
D_{MAX}	Maximum duty cycle		92	95		%
OVP	Over voltage threshold	Measured at OUTPUT		39		V
T_S	Start-up time			1.5		ms
Logic Signal						
V_{TH-L}	Logic low threshold				0.4	V
V_{TH-H}	Logic high threshold		1.4			V
T_{OFF}	EN low to shutdown time			1.8		ms
Ndim	Pulse dimming steps			32		
T_{J-TH}	IC junction thermal shutdown threshold			145		$^{\circ}C$
	IC junction thermal shutdown hysteresis			15		$^{\circ}C$

Specifications subject to change without notice.

Application Circuit

In typical application, DIO5310 is competent in the below two configurations: 10 series LED-Array and 3(row)x13 LED Matrix. As depicted in following figures:

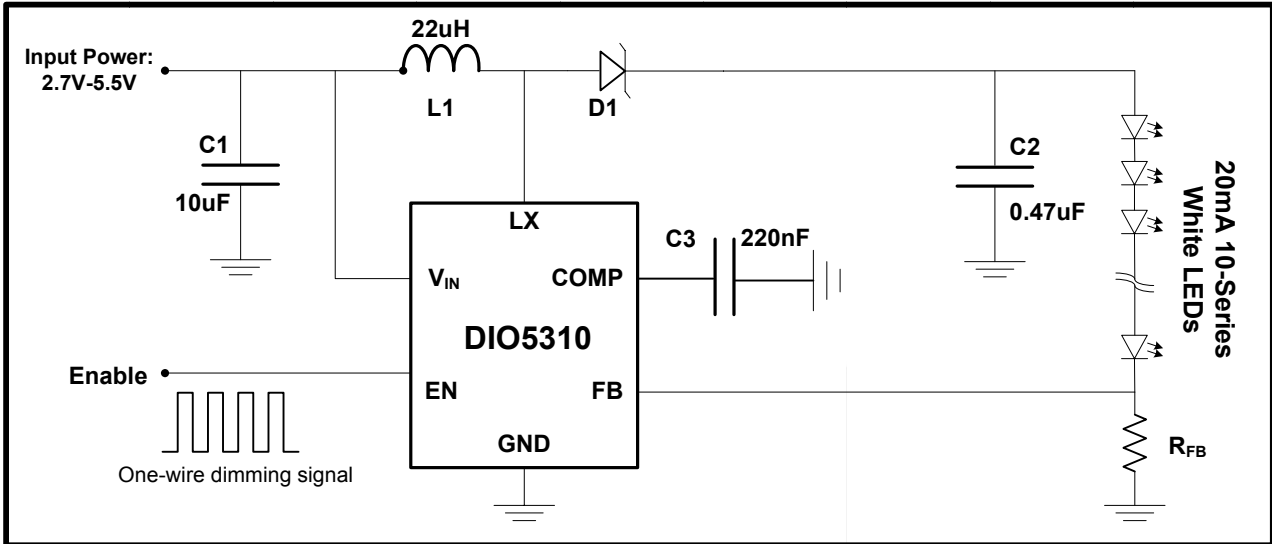

Figure 2. 10 Series LED Array Application Circuit Configuration

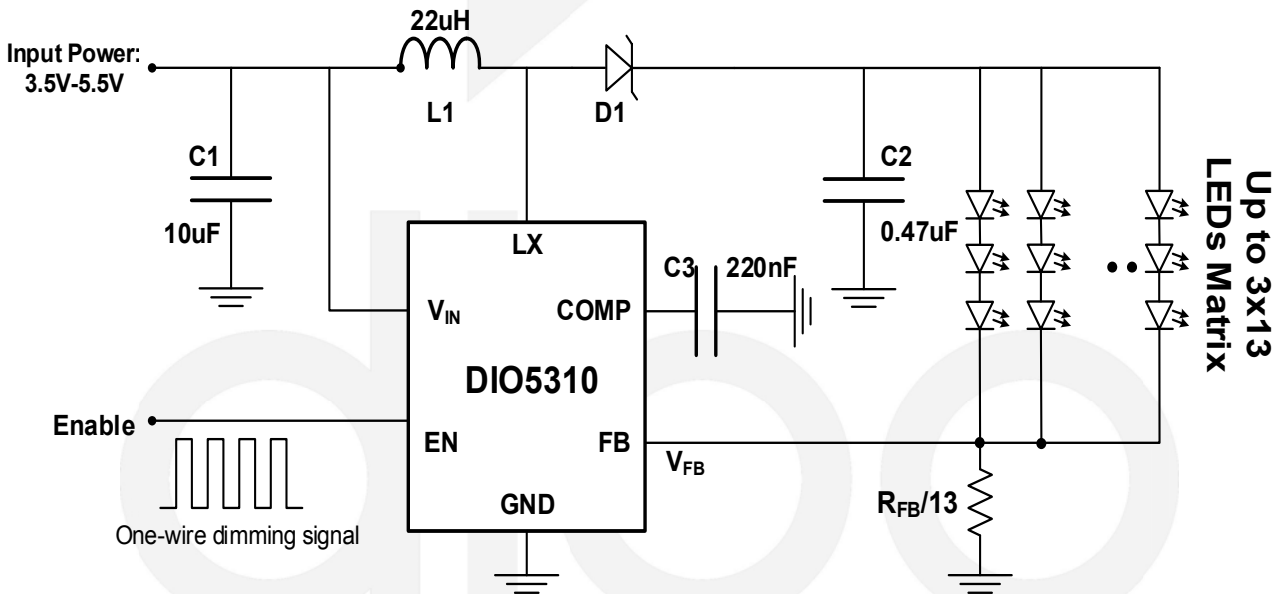

Figure 3. 3x13 (3 LEDs in row) LED Matrix Application Circuit Configuration

Functional Block Diagram

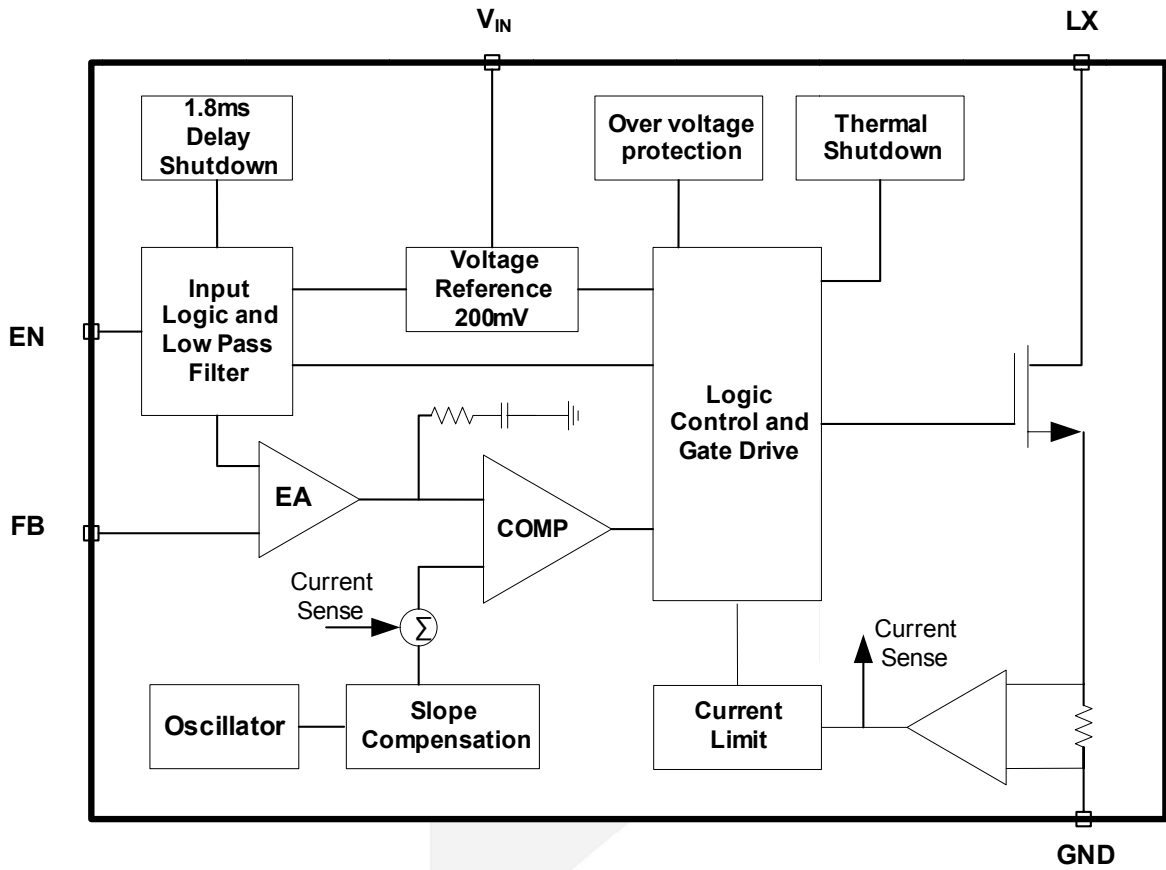

Figure 4. Functional Block Diagram



Operation Principle

DIO5310 utilizes a constant frequency current-mode boost converter architecture to power white LED strings or arrays by pumping current precisely regulated by feedback voltage V_{FB} and feedback resistor R_{FB} , illustrated in Figure 6.

As illuminated in the Functional Block Diagram above, Logic Control and Gate Drive Block periodically opens and closes the Power MOSFET synchronized with Oscillator. At the rising edge of Oscillator pulse, Power MOSFET is turned on, while closed when the comparator COMP tells the Current Sense slope signal goes above the output "difference" of error amplifier EA. The current slope is generated by Current Sense from sampling inductor charging current and compensated by Slope Compensation. And the output "difference" comes from comparing feedback voltage V_{FB} with internal reference voltage V_{REF} by Error Amplifier EA. Both the two close loops assure the output current stabilization and make feedback voltage V_{FB} in consistency with reference voltage V_{REF} .

DIO5310 integrates soft-start to limit the inrush current and the overshoot on the output. And DIO5310 also features internal protection circuits such as over-voltage protection (OVP), cycle-by-cycle current limit protection and thermal shutdown.

DIO5310 adopts one-wire dimming control by regulating the reference voltage. Pin EN listens serial pulses, counts the number of rising edges, then decodes the serial signal to 32 different levels by a 5-bit register. After powered on, the DIO5310 starts up once detecting an active high pulse longer than 2us. And then a 3ms long low pulse will shutdown the circuit. More is illustrated in the Pin EN Timing graph.

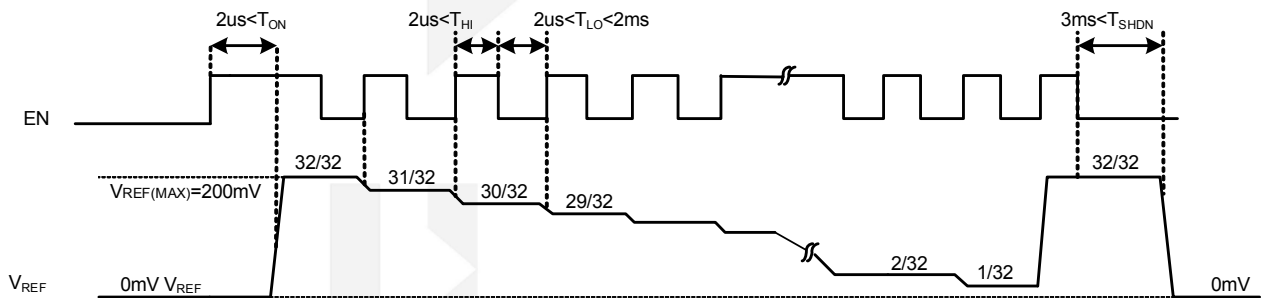

Figure 5. Timing of Pin EN

Application Notes:

MAX LED Current Settings

LED Current is determined by the current through the feedback resistor R_{FB} , as depicted in the right-hand figure. V_{FB} is a high-impedance state output feedback voltage, so no current goes through Pin FB and the built-in "boost" DC/DC has to pump current to feed I_{FB} .

$$I_{LED} = I_{FB} = V_{FB}/R_{FB}$$

V_{FB} is internally set to a maximum value of 200mV.

So

$$I_{LED(MAX)} = 200mV/R_{FB}$$

For LED current accuracy, 1% precision resistor is recommended.

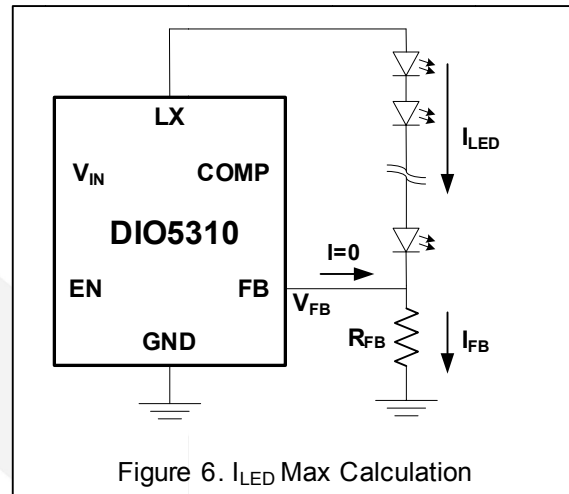

Feedback Voltage V_{FB} Calculation

The feedback voltage V_{FB} is regulated by the internal reference voltage V_{REF} , So the V_{FB} is approximately same as V_{REF} in the timing, except for that V_{FB} always has a delay with respect to V_{REF} since both in the start-up or the dimming process, the system takes time to adjust V_{FB} equal to V_{REF} . if we neglect these delays, V_{FB} changes with Pin EN signal just as the V_{REF} .

Recommended LED Dimming Method for 10-LEDs series Application

If we set $R_{FB} = 10.0\Omega$, so $I_{LED(MAX)}=20mA$, then we have I_{LED} changes with EN as the following:

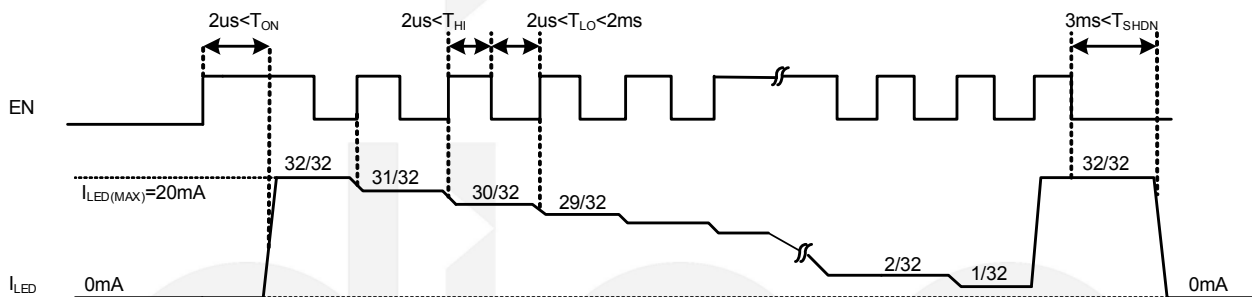

Figure 7. LED Current Setting Timing vs EN Series Signal

Inductor Selection

A 10uH~22uH inductor is recommended for both 10-LED serial string and 3x13 LED matrix application. A low DCR inductor could be suggested if a high efficiency is critical. The inductor's saturation current rating should also exceed the peak input current, especially for high load current application such as 3x13 matrix.

Table 1. Inductor Selector

Part Number	Inductor(μ H) @100KHz, 1V	DCR(Ω) +/-30%	Min. Self-resonant Frequency(MHz)	Saturation Current(A)	Heat Rating Current(A)
SWPA8040S100MT	10+/-20%	0.029	15	3.60	3.30
SWPA8040S220MT	22+/-20%	0.069	9.5	2.40	2.10

Capacitor Selection

Small size ceramic capacitors are recommended for DIO5310 application. A 10 μ F input capacitor and a 0.47 μ F output capacitor are recommended for 10/8/6-Series LED applications. Larger value output capacitors like 2.2 μ F are recommended in higher output current applications to minimize output ripple. Ceramic capacitor Vendors such as Murata, AVX, Taiyo Yuden are recommended.

Diode Selection

Since DIO5310's low forward voltage drop and fast reverse recovery time, a schottky diode is recommended. The current rating of the schottky diode should exceed the peak current of the boost converter. The voltage rating should also exceed the target output voltage.

Table 2. Diode Selector

Applications	Schottky Diode Part Number	Forward Voltage(V)	Forward Current(mA)	Reverse Voltage(V)	Manufacturer
20mA, 8/10 Serial LEDs 39V OVP	PMEG6010CEJ	0.57	1000	60	NXP

PCB Layout Design Recommendation

As for all switching power supplies, especially those high frequency and high current ones, layout is an important design step. If layout is not carefully done, the regulator could suffer from instability as well as noise problems. To reduce switching losses, the LX pin rise and fall times are made as short as possible. To prevent radiation of high frequency resonance problems, proper layout of the high frequency switching path is essential. Minimize the length and area of all traces connected to the LX pin and always use a ground plane under the switching regulator to minimize inter-plane coupling. The loop including the PWM switch, Schottky diode, and output capacitor, contains high current rising and falling in nanosecond and should be kept as short as possible. The input capacitor needs not only to be close to the V_{IN} pin, but also to the GND pin in order to reduce the IC supply ripple. Figure 8 shows a sample layout.

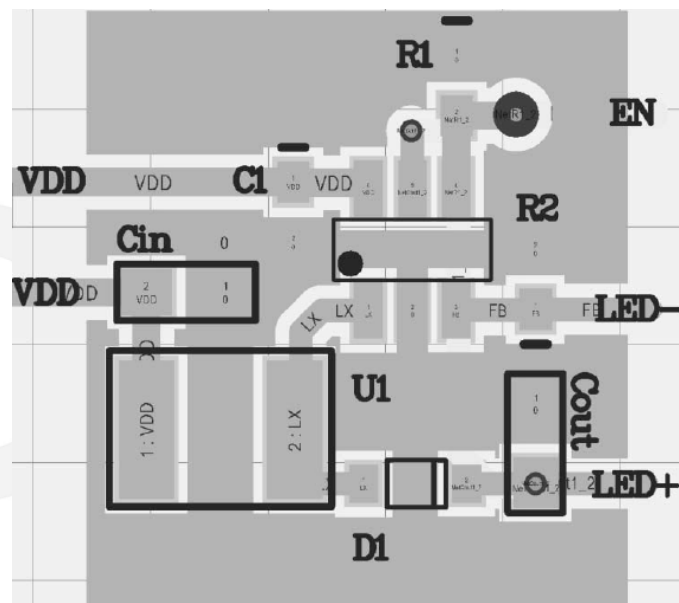
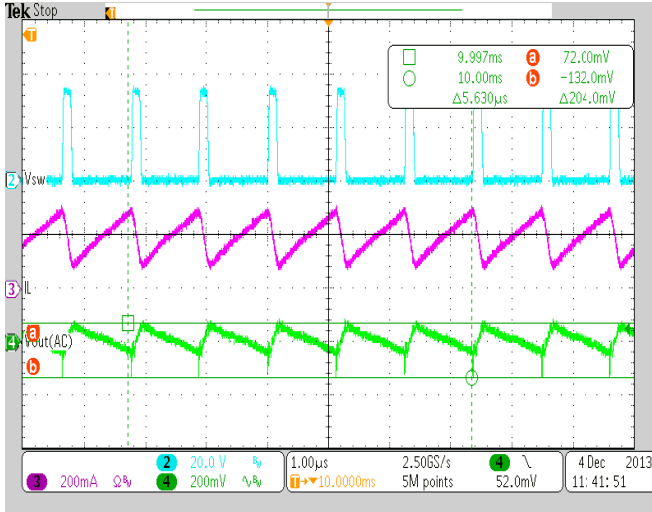

Figure 8. PCB Layout recommended

Typical Performance Characteristics

$V_{IN} = 4.2V$, $L = 22\mu H$, $C_{IN} = 10\mu F$, $C_{OUT} = 10\mu F$, $T_A = 25^\circ C$, unless otherwise noted.

Stability waveform



Open load at startup

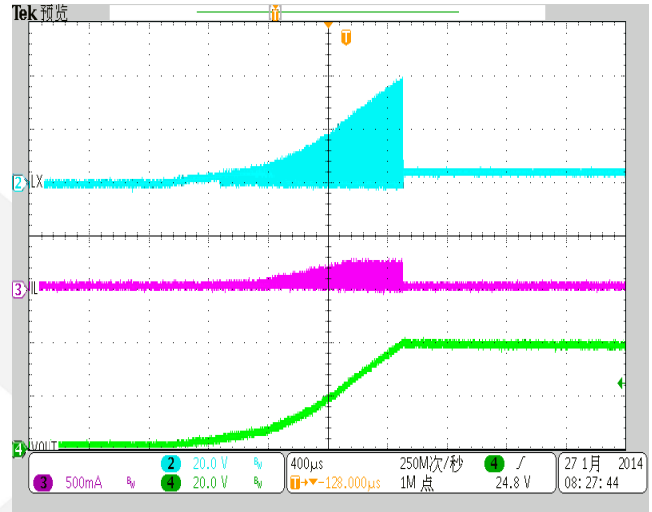

Open load at working

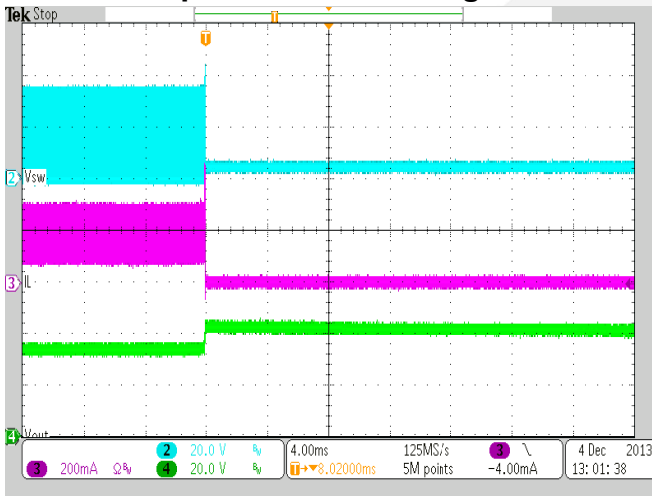

Dimming waveform

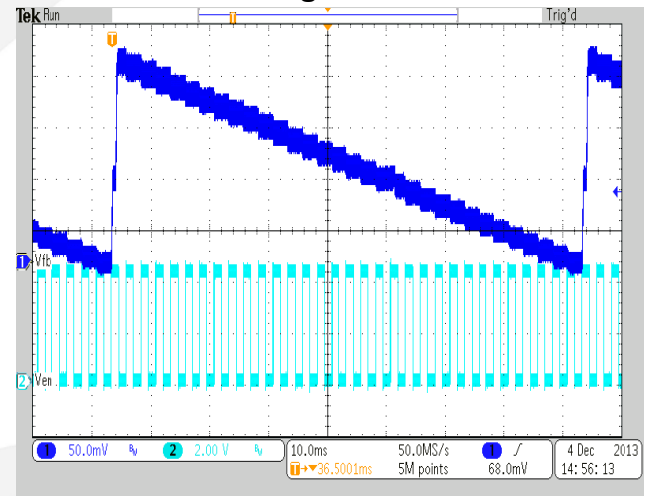

CONTACT US

Dioo is a professional design and sales corporation for high-quality and performance analog semiconductors. The company focuses on industry markets, such as, cell phone, handheld products, laptop, and medical equipment and so on. Dioo's product families include analog signal processing and amplifying, LED drivers and charger IC. Go to <http://www.dioo.com> for a complete list of Dioo product families.

For additional product information, or full datasheet, please contact with our Sales Department or Representatives.

