

general purpose 2%, 5% tolerance thick film chip resistor

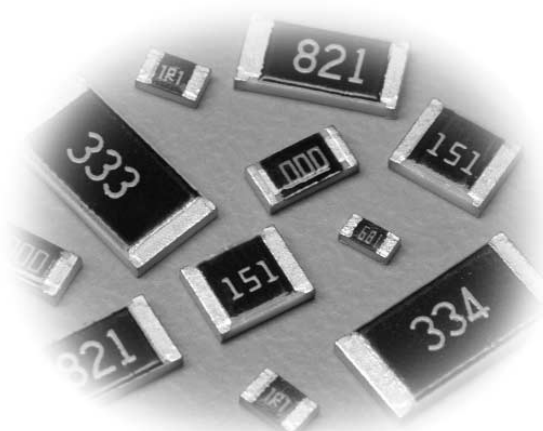

features

- RuO₂ thick film resistor element
- Anti-leaching nickel barrier terminations
- Also available with epoxy bondable palladium silver terminations in 1J, 2A and 2B sizes.
- Meets or exceeds EIA 575, EIAJ RC 2690A, EIA PDP-100, MIL-R-55342F
- Marking: White three-digit on black protective coat
No marking on 1F, 1H and 1E sizes

dimensions and construction

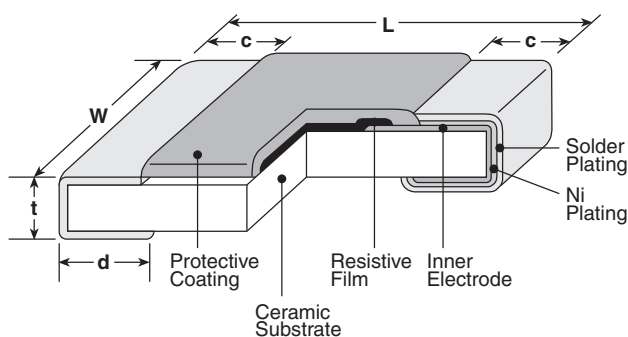

Type (Inch Size Code)	Dimensions inches (mm)				
	L	W	c	d	t
NEW 1F (01005)	.015±.001 (0.4±0.02)	.007±.001 (0.2±0.02)	.004±.001 (0.1±0.03)	.004±.001 (0.1±0.03)	.005±.001 (0.12±0.02)
1H (0201)	.024±.001 (0.6±0.03)	.012±.001 (0.3±0.03)	.004±.002 (0.1±0.05)	.006±.002 (0.15±0.05)	.009±.001 (0.23±0.03)
1E (0402)	.039 ^{+0.004} _{-.002} (1.0 ^{+0.1} _{-0.05})	.02±.002 (0.5±0.05)	.008±.004 (0.2±0.1)	.01 ^{+0.002} _{-.004} (0.25 ^{+0.05} _{-0.1})	.014±.002 (0.35±0.05)
1J (0603)	.063±.008 (1.6±0.2)	.031±.004 (0.8±0.1)	.012±.004 (0.3±0.1)	.012±.004 (0.3±0.1)	.018±.004 (0.45±0.1)
2A (0805)	.079±.008 (2.0±0.2)	.049±.004 (1.25±0.1)	.016±.008 (0.4±0.2)	.012 ^{+0.008} _{-.004} (0.3 ^{+0.2} _{-0.1})	.02±.004 (0.5±0.1)
2B (1206)	.126±.008 (3.2±0.2)	.063±.008 (1.6±0.2)	.02±.012 (0.5±0.3)	.016 ^{+0.008} _{-.004} (0.4 ^{+0.2} _{-0.1})	.024±.004 (0.6±0.1)
2E (1210)		.102±.008 (2.6±0.2)			
2H (2010)	.197±.008 (5.0±0.2)	.098±.008 (2.5±0.2)		.025±.005 (0.65±0.15)	
3A (2512)	.248±.008 (6.3±0.2)	.122±.008 (3.1±0.2)			

ordering information

New Part #	RK73B	2B	T	TD	102	J
Type		Size	Termination Material	Packaging	Nominal Resistance	Tolerance
		1F 1H 1E 1J 2A 2B 2E 2H 3A	T: Sn X: AgPd** G: Au* L: SnPb	TC: 2mm pitch punched pressed paper (01005 & 0201 only) TB: 2mm pitch pressed paper (0201 only) TP: 2mm pitch punched paper (0402 & 0603) TD: 7" paper tape (0603, 0805, 1206 & 1210) TDD: 10" paper tape (0603, 0805, 1206 & 1210) TE: 7" punched plastic (0805, 1206, 1210, 2010 & 2512) TED: 10" punched plastic (0805, 1206, 1210, 2010 & 2512)	2 significant figures + 1 multiplier "R" indicates decimal on value <10Ω	G: ±2% J: ±5%

* Available ONLY in 1E, 1J and 2A (10Ω - 1MΩ) chip sizes

** Available ONLY in 1J, 2A and 2B (10Ω ~ 22MΩ) chip sizes

For further information on packaging, please refer to Appendix A.

Specifications given herein may be changed at any time without prior notice. Please confirm technical specifications before you order and/or use.

4/20/05

applications and ratings

	Part Designation*	Power Rating @ 70°C	T.C.R. (ppm/°C) Max.	Resistance Range E-24** (G±2%)	Resistance Range E-24** (J±5%)	Absolute Maximum Working Voltage	Absolute Maximum Overload Voltage	Operating Temperature Range***
UNDER DEVELOPMENT	RK73B1F (01005)	1/32W (.03W)	±250	10Ω - 1MΩ	10Ω - 1MΩ	15V	30V	-55°C to +125°C
	RK73B1H (0201)	1/20W (.05W)	±200 ±400	10Ω - 10MΩ —	10Ω - 10MΩ 1Ω - 9.1Ω	25V	50V	
	RK73B1E (0402)	1/16W (.063W)	±200 ±400	10Ω - 1MΩ —	10Ω - 10MΩ 1.0Ω - 9.1Ω	50V	100V	-55°C to +155°C
	RK73B1J (0603)	1/10W (.10W)	±200 ±400	10Ω - 10MΩ 1Ω - 9.1Ω	10Ω - 10MΩ 1Ω - 9.1Ω 11MΩ - 22MΩ			
	RK73B2A (0805)	1/8W (.125W)	±200 ±400	10Ω - 1MΩ 1Ω - 9.1Ω 1.1MΩ - 10MΩ	10Ω - 1MΩ 1Ω - 9.1Ω 1.1MΩ - 22MΩ	150V	300V	
	RK73B2B (1206)	1/4W (.25W)	±200 ±400	10Ω - 5.6MΩ 1Ω - 9.1Ω 6.2MΩ - 10MΩ	10Ω - 5.6MΩ 1Ω - 9.1Ω 6.2MΩ - 22MΩ	200V	400V	
	RK73B2E (1210)	1/2W (.50W)	±200	10Ω - 1KΩ	10Ω - 1KΩ			
		1/3W (.33W)	±200	1.1KΩ - 5.6MΩ	1.1KΩ - 5.6MΩ			
	RK73B2H (2010)	1/2W (.50W)	±400	—	1Ω - 9.1Ω			
		1/3W (.33W)	±400	—	6.2MΩ - 10MΩ			
	RK73B3A (2512)	1W	±200 ±400	10Ω - 5.6MΩ —	10Ω - 5.6MΩ 1Ω - 9.1Ω 6.2MΩ - 22MΩ	500V		

* Parenthesis indicate EIA package size codes.

** See Appendix D for available decade values.

*** 1J, 2A, 2B sizes available -55°C to +175°C (contact factory).

environmental applications

Derating Curve

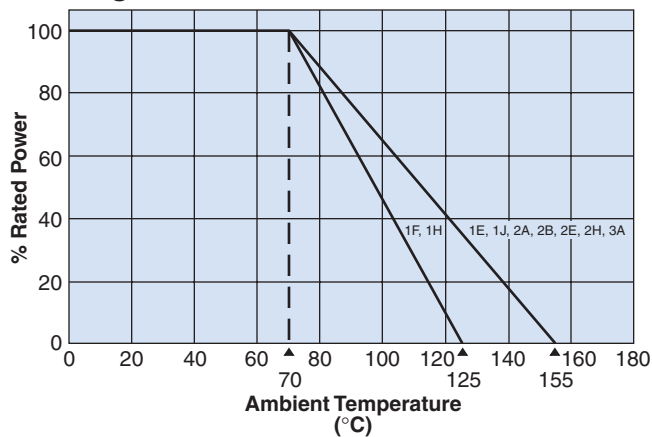

Surface Temperature Rise

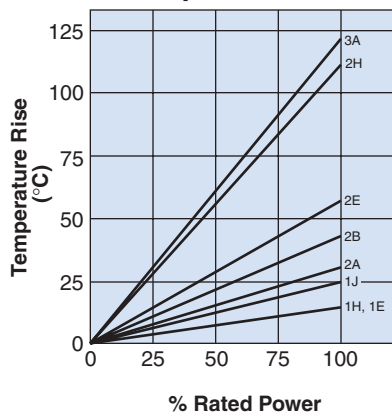

For complete environmental specifications, please refer to pages 24-25.