

**MITSUBISHI HIGH SPEED CMOS**  
**M74HC283P/FP/DP**

**4-BIT BINARY FULL ADDER WITH FAST CARRY**

**DESCRIPTION**

The M74HC283 is a semiconductor integrated circuit consisting of a 4-bit full adder.

**FEATURES**

- High-speed: 30ns typ. ( $C_L=15pF, V_{CC}=5V$ )
- Low power dissipation:  $20\mu W$ /package, max ( $V_{CC}=5V, T_a=25^\circ C$ , quiescent state)
- High noise margin: 30% of  $V_{CC}$ , min ( $V_{CC}=4.5V, 6V$ )
- Capable of driving 10 74LS TTL loads
- Wide operating voltage range:  $V_{CC}=2\sim 6V$
- Wide operating temperature range:  $T_a=-40\sim +85^\circ C$

**APPLICATION**

General purpose, for use in industrial and consumer digital equipment.

**FUNCTIONAL DESCRIPTION**

Use of silicon gate technology allows the M74HC283 to maintain the low power dissipation and high noise margin characteristics of the standard CMOS logic 4000B series while giving high-speed performance equivalent to the 74LS283.

The M74HC283 is a 4-bit binary full adder. When 4-bit binary values applied inputs A0~A3 and B0~B3, and the carry signal from the previous stage is applied to carry input CI, the corresponding sum output for the respective bits will appear at S0~S3 and the carry output will appear at C0.

**PIN CONFIGURATION (TOP VIEW)**

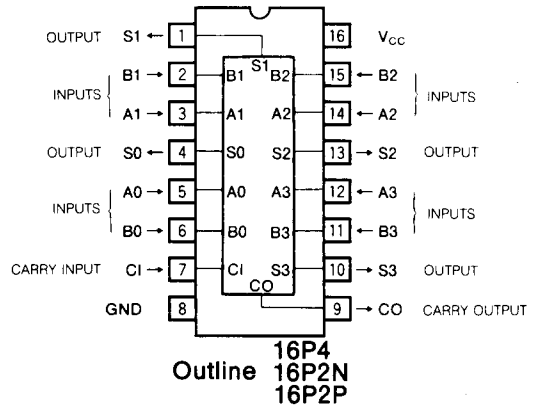

**FUNCTION TABLE (Note 1)**

Inputs			Outputs	
$C_{K-1}$	$A_K$	$B_K$	$S_K$	$C_K$
L	L	L	L	L
L	H	L	H	L
L	L	H	H	L
L	H	H	L	H
H	L	L	H	L
H	H	L	L	H
H	L	H	L	H
H	H	H	H	H

Note 1 :  $S_K$  and  $C_K$  are sum and carry outputs generated by the sum of addends  $A_K$  and  $B_K$  and carry input  $C_{K-1}$ . Their values are given by the following logical equations.

$$S_k = A_k \oplus B_k \oplus C_{k-1}$$

$$C_k = A_k \cdot B_k + (A_k + B_k) \cdot C_{k-1}$$

$k=0\sim 3$

$\oplus$  = Exclusive OR  
 $+$  = OR  
 $\cdot$  = AND

**LOGIC DIAGRAM**

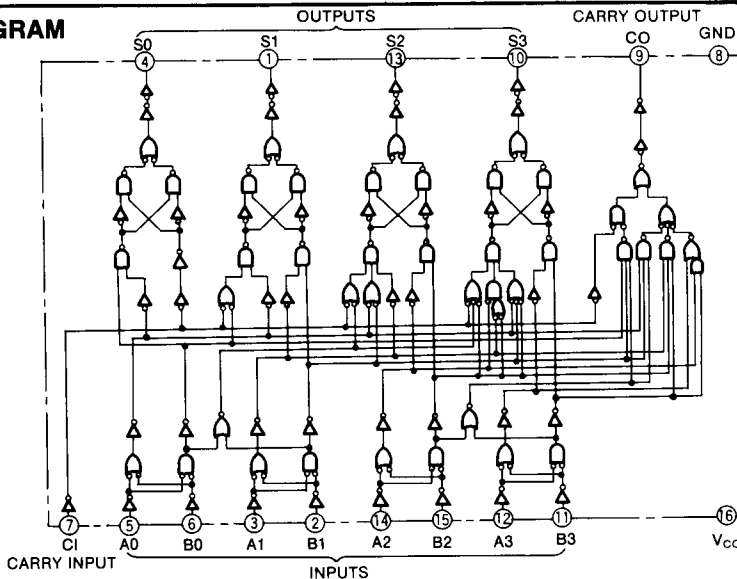

4-BIT BINARY FULL ADDER WITH FAST CARRY

ABSOLUTE MAXIMUM RATINGS ( $T_a = -40 \sim +85^\circ\text{C}$ , unless otherwise noted)

Symbol	Parameter	Conditions	Ratings	Unit
$V_{CC}$	Supply voltage		$-0.5 \sim +7.0$	V
$V_I$	Input voltage		$-0.5 \sim V_{CC} + 0.5$	V
$V_O$	Output voltage		$-0.5 \sim V_{CC} + 0.5$	V
$I_{IK}$	Input protection diode current	$V_I < 0V$	-20	mA
		$V_I > V_{CC}$	20	
$I_{OK}$	Output parasitic diode current	$V_O < 0V$	-20	mA
		$V_O > V_{CC}$	20	
$I_O$	Output current per output pin		$\pm 25$	mA
$I_{CC}$	Supply/GND current	$V_{CC}, GND$	$\pm 50$	mA
$P_d$	Power dissipation	(Note 2)	500	mW
$T_{stg}$	Storage temperature range		$-65 \sim +150$	$^\circ\text{C}$

Note 2 : M74HC283FP,  $T_a = -40 \sim +70^\circ\text{C}$  and  $T_a = 70 \sim 85^\circ\text{C}$  are derated at  $-6\text{mW}/^\circ\text{C}$ .  
M74HC283DP,  $T_a = -40 \sim +50^\circ\text{C}$  and  $T_a = 50 \sim 85^\circ\text{C}$  are derated at  $-5\text{mW}/^\circ\text{C}$ .

RECOMMENDED OPERATING CONDITIONS ( $T_a = -40 \sim +85^\circ\text{C}$ )

Symbol	Parameter	Limits			Unit
		Min	Typ	Max	
$V_{CC}$	Supply voltage	2		6	V
$V_I$	Input voltage	0		$V_{CC}$	V
$V_O$	Output voltage	0		$V_{CC}$	V
$T_{opr}$	Ambient operating temperature	-40		+85	$^\circ\text{C}$
$t_r, t_f$	Input risetime, falltime	$V_{CC} = 2.0V$	0	1000	ns
		$V_{CC} = 4.5V$	0	500	
		$V_{CC} = 6.0V$	0	400	

ELECTRICAL CHARACTERISTICS

Symbol	Parameter	Test conditions	Limits					Unit	
			$V_{CC}(V)$	25 $^\circ\text{C}$			$-40 \sim +85^\circ\text{C}$		
				Min	Typ	Max	Min		Max
$V_{IH}$	High-level input voltage	$V_O = 0.1V, V_{CC} - 0.1V$ $ I_O  = 20\mu A$	2.0	1.5			1.5	V	
			4.5	3.15			3.15		
			6.0	4.2			4.2		
$V_{IL}$	Low-level input voltage	$V_O = 0.1V, V_{CC} - 0.1V$ $ I_O  = 20\mu A$	2.0			0.5		0.5	
			4.5			1.35		1.35	
			6.0			1.8		1.8	
$V_{OH}$	High-level output voltage	$V_I = V_{IH}, V_{IL}$	$I_{OH} = -20\mu A$	2.0	1.9			1.9	V
			$I_{OH} = -20\mu A$	4.5	4.4			4.4	
			$I_{OH} = -20\mu A$	6.0	5.9			5.9	
			$I_{OH} = -4.0\text{mA}$	4.5	4.18			4.13	
			$I_{OH} = -5.2\text{mA}$	6.0	5.68			5.63	
$V_{OL}$	Low-level output voltage	$V_I = V_{IH}, V_{IL}$	$I_{OL} = 20\mu A$	2.0		0.1		0.1	V
			$I_{OL} = 20\mu A$	4.5		0.1		0.1	
			$I_{OL} = 20\mu A$	6.0		0.1		0.1	
			$I_{OL} = 4.0\text{mA}$	4.5		0.26		0.33	
			$I_{OL} = 5.2\text{mA}$	6.0		0.26		0.33	
$I_{IH}$	High-level input current	$V_I = 6V$	6.0			0.1		1.0	$\mu A$
$I_{IL}$	Low-level input current	$V_I = 0V$	6.0			-0.1		-1.0	$\mu A$
$I_{CC}$	Quiescent supply current	$V_I = V_{CC}, GND, I_O = 0\mu A$	6.0			4.0		40.0	$\mu A$

4-BIT BINARY FULL ADDER WITH FAST CARRY

SWITCHING CHARACTERISTICS ( $V_{CC} = 5V, T_a = 25^\circ C$ )

Symbol	Parameter	Test conditions	Limits			Unit
			Min	Typ	Max	
$t_{TLH}$	Low-level to high-level and high-level to low-level output transition time	$C_L = 15pF$ (Note 4)			10	ns
$t_{THL}$					10	
$t_{PLH}$	Low-level to high-level and high-level to low-level output propagation time (CI - SK)				38	ns
$t_{PHL}$					38	
$t_{PHL}$	Low-level to high-level and high-level to low-level output propagation time ( $A_K, B_K - S_K$ )				49	ns
$t_{PLH}$	Low-level to high-level and high-level to low-level output propagation time (CI - CO)				31	ns
$t_{PHL}$					31	
$t_{PLH}$	Low-level to high-level and high-level to low-level output propagation time ( $A_K, B_K - CO$ )				41	ns
$t_{PHL}$					41	

SWITCHING CHARACTERISTICS ( $V_{CC} = 2\sim 6V, T_a = -40\sim +85^\circ C$ )

Symbol	Parameter	Test conditions	Limits						Unit
			$V_{CC}(V)$	25°C			-40~+85°C		
				Min	Typ	Max	Min	Max	
$t_{TLH}$	Low-level to high-level and high-level to low-level output transition time	$C_L = 50pF$ (Note 4)	2.0			75		90	ns
			4.5			15		18	
			6.0			13		16	
$t_{THL}$	output transition time		2.0			75		90	ns
			4.5			15		18	
			6.0			13		16	
$t_{PLH}$	Low-level to high-level and high-level to low-level output propagation time (CI - SK)		2.0			210		265	ns
			4.5			42		53	
			6.0			36		45	
$t_{PHL}$	high-level to low-level output propagation time ( $A_K, B_K - S_K$ )	2.0			210		265	ns	
		4.5			42		53		
		6.0			36		45		
$t_{PHL}$	Low-level to high-level and high-level to low-level output propagation time (CI - CO)	2.0			270		340	ns	
		4.5			54		68		
		6.0			46		58		
$t_{PLH}$	Low-level to high-level and high-level to low-level output propagation time (CI - CO)	2.0			175		220	ns	
		4.5			35		44		
		6.0			30		37		
$t_{PHL}$	Low-level to high-level and high-level to low-level output propagation time ( $A_K, B_K - CO$ )	2.0			175		220	ns	
		4.5			35		44		
		6.0			30		37		
$t_{PLH}$	Low-level to high-level and high-level to low-level output propagation time ( $A_K, B_K - CO$ )	2.0			225		280	ns	
		4.5			45		56		
		6.0			38		48		
$t_{PHL}$	output propagation time ( $A_K, B_K - CO$ )	2.0			225		280	ns	
		4.5			45		56		
		6.0			38		48		
$C_I$	Input capacitance				10		10	pF	
$C_{PD}$	Power dissipation capacitance (Note 3)							pF	

Note 3 :  $C_{PD}$  is the internal capacitance of the IC calculated from operation supply current under no-load conditions. The power dissipated during operation under no-load conditions is calculated using the following formula:

$$P_D = C_{PD} \cdot V_{CC}^2 \cdot f_I + I_{CC} \cdot V_{CC}$$

4-BIT BINARY FULL ADDER WITH FAST CARRY

Note 4 : Test Circuit

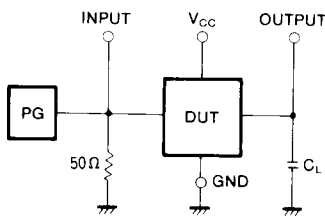

- (1) The pulse generator (PG) has the following characteristics (10%~90%):  $t_r = 6\text{ns}$ ,  $t_f = 6\text{ns}$
- (2) The capacitance  $C_L$  includes stray wiring capacitance and the probe input capacitance.

TIMING DIAGRAM

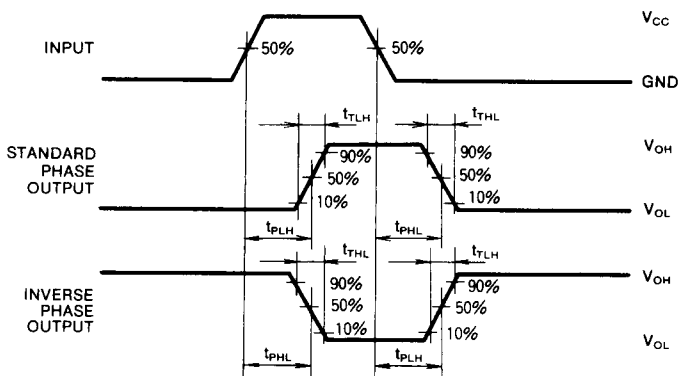

APPLICATION EXAMPLE

The 4N-bit binary parallel adder using N pieces of the M74HC283 is shown in the following.

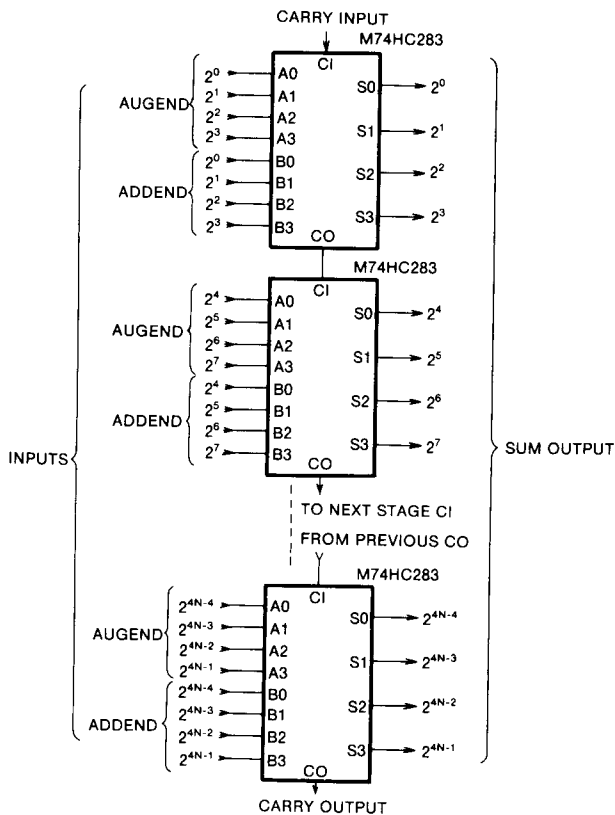

MITSUBISHI HIGH SPEED CMOS  
PACKAGE OUTLINES

6249827 MITSUBISHI (DGTL LOGIC)

91D 12849

D T-90-20

TYPE 14P4 14-PIN MOLDED PLASTIC DIP

Dimension in mm

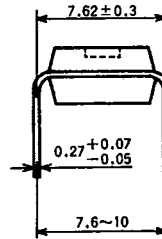
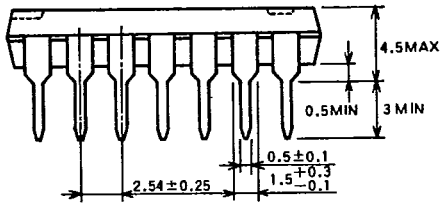
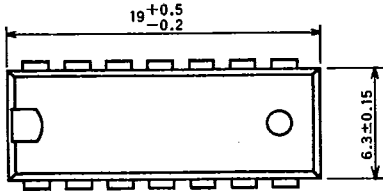

TYPE 16P4 16-PIN MOLDED PLASTIC DIP

Dimension in mm

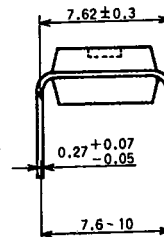
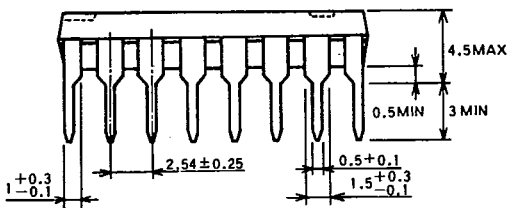
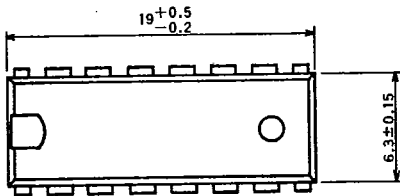

MITSUBISHI HIGH SPEED CMOS  
**PACKAGE OUTLINES**

6249827 MITSUBISHI (DGTL LOGIC)

91D 12850 D.T-90-20

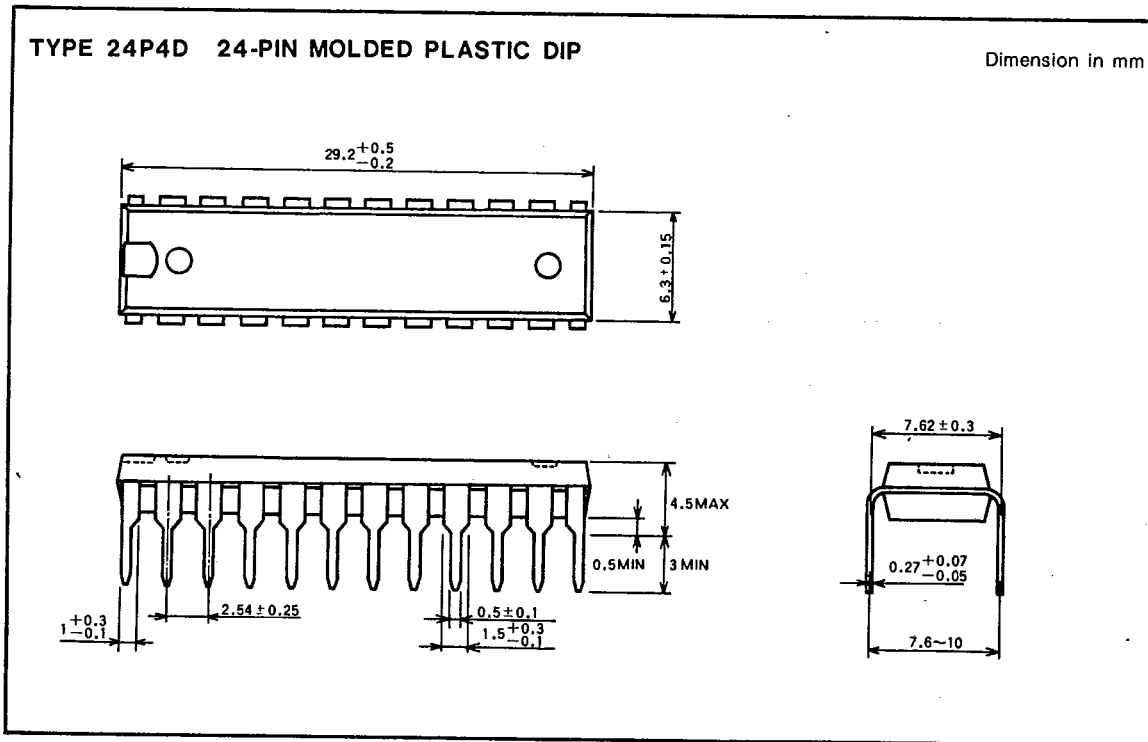
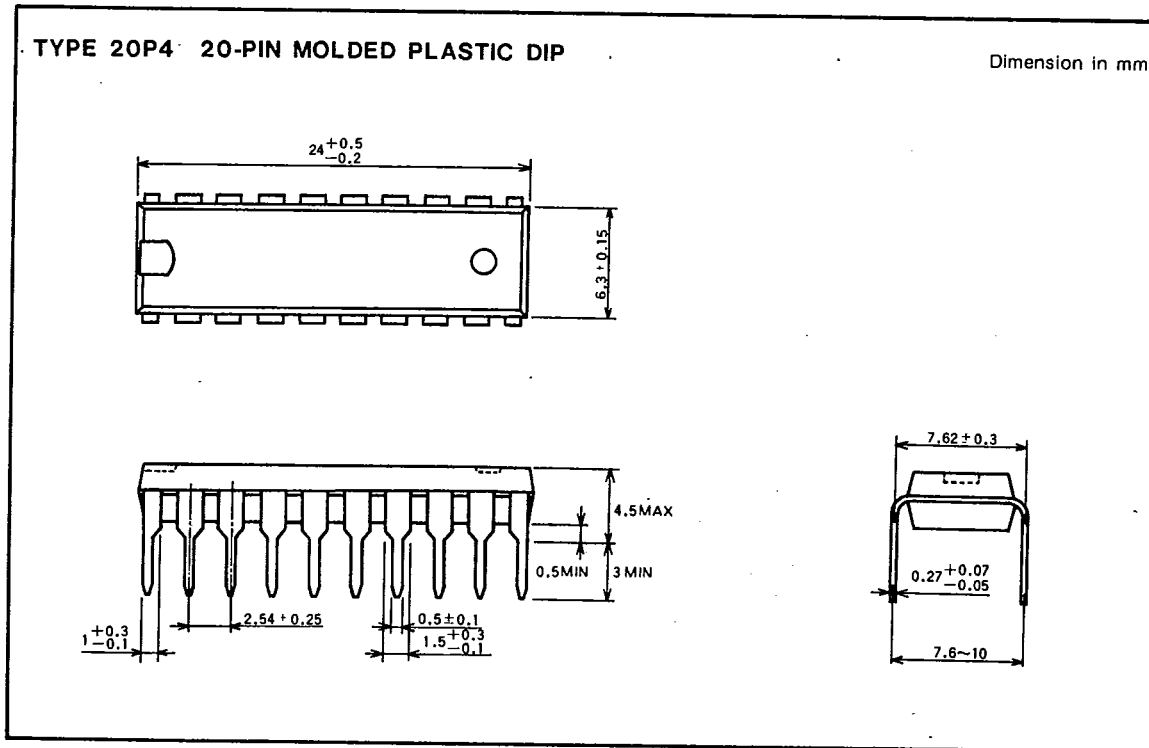

2933

G-02

1-52



MITSUBISHI ELECTRIC CO. TOKYO, JAPAN

MITSUBISHI HIGH SPEED CMOS  
PACKAGE OUTLINES

6249827 MITSUBISHI (DGTL LOGIC)

91D 12851 D T-90.20

TYPE 14P2N 14PIN MOLDED PLASTIC SOP

Dimension in mm

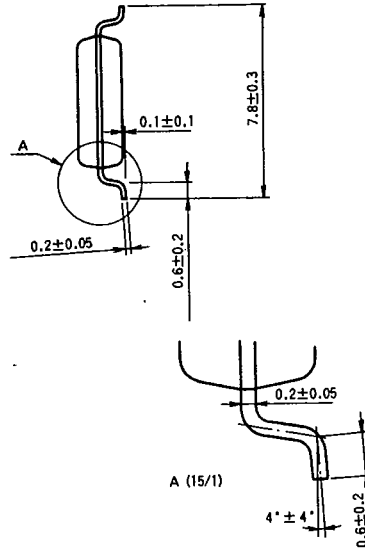
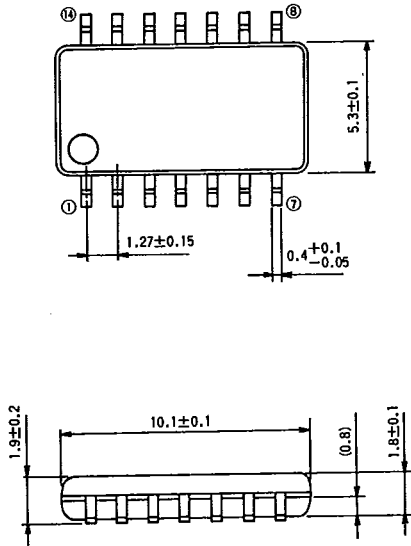

TYPE 16P2N 16PIN MOLDED PLASTIC SOP

Dimension in mm

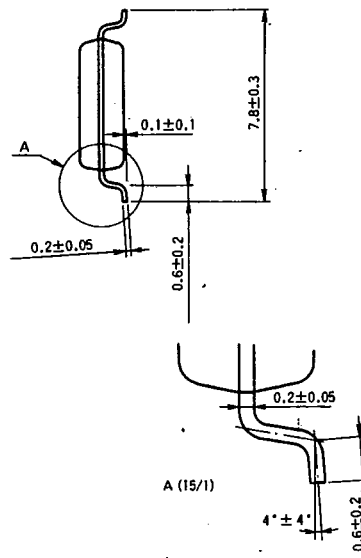
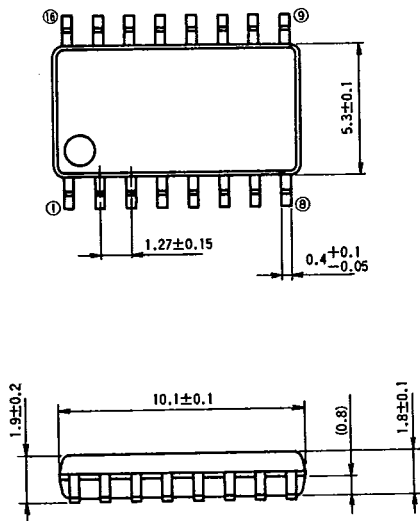

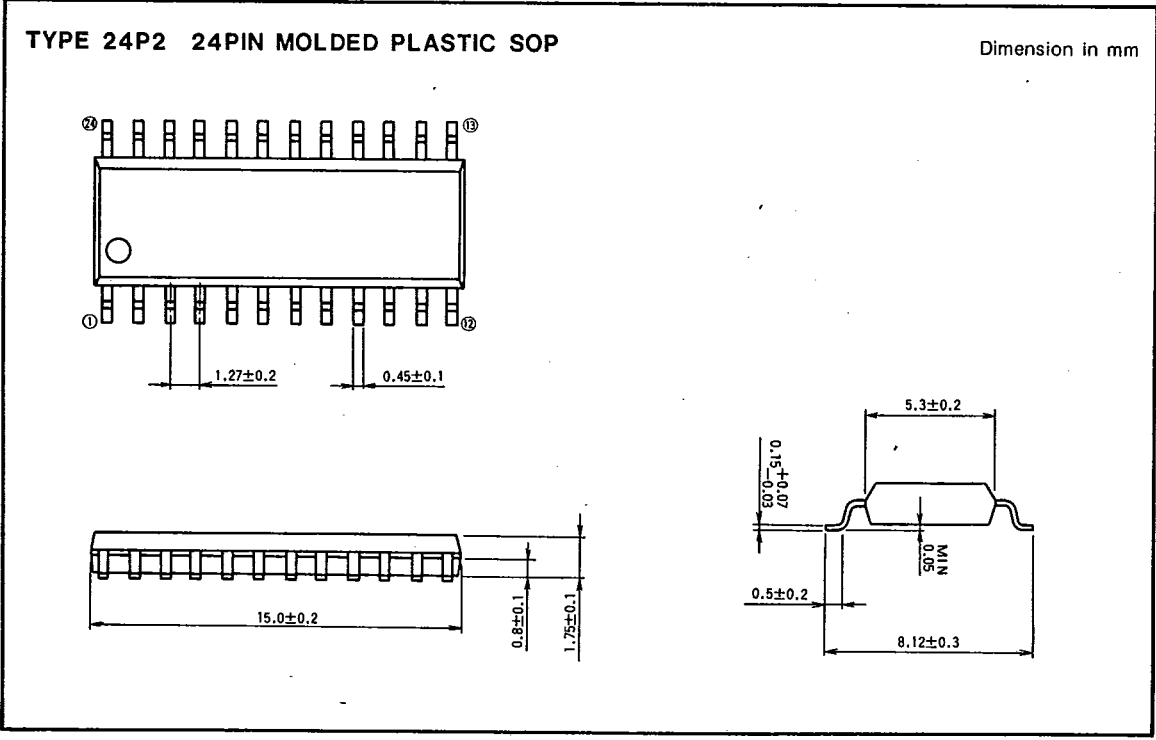
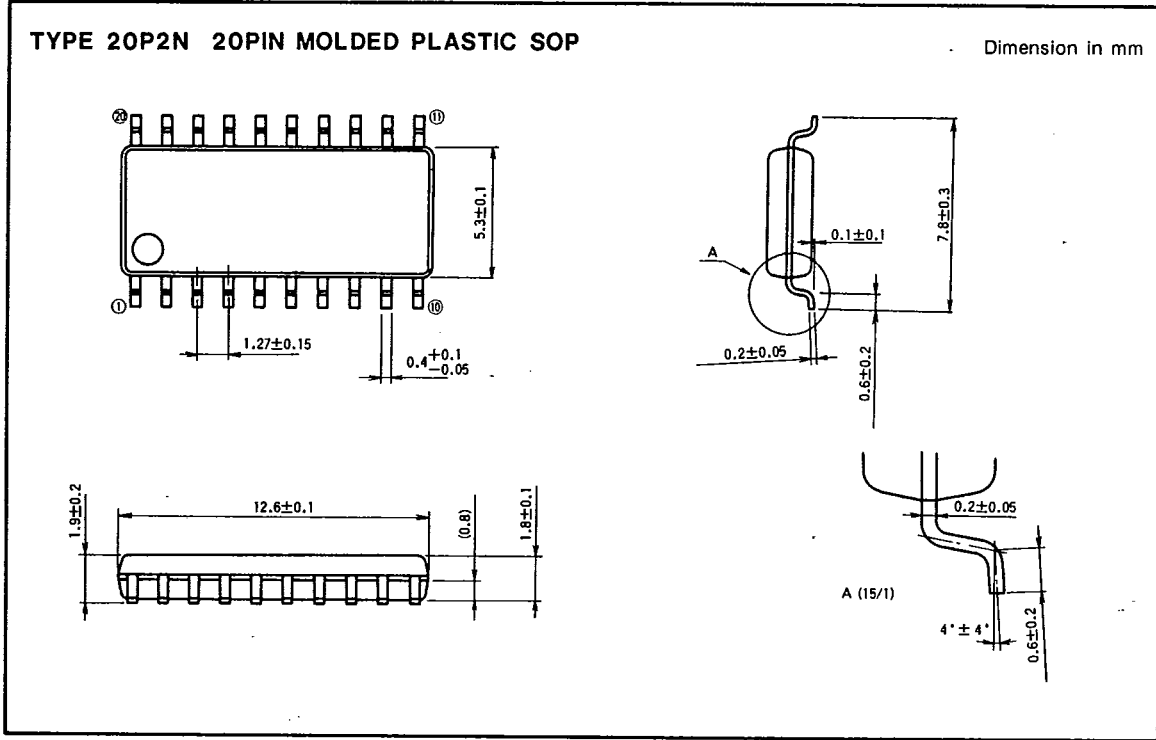

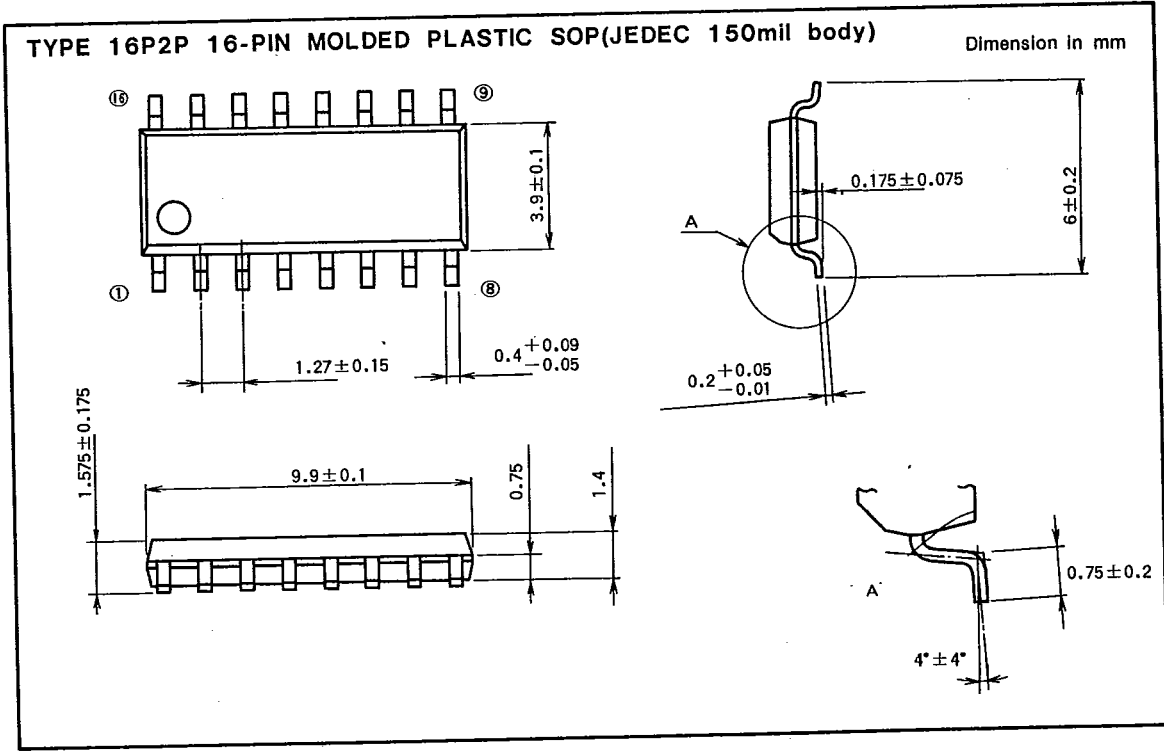
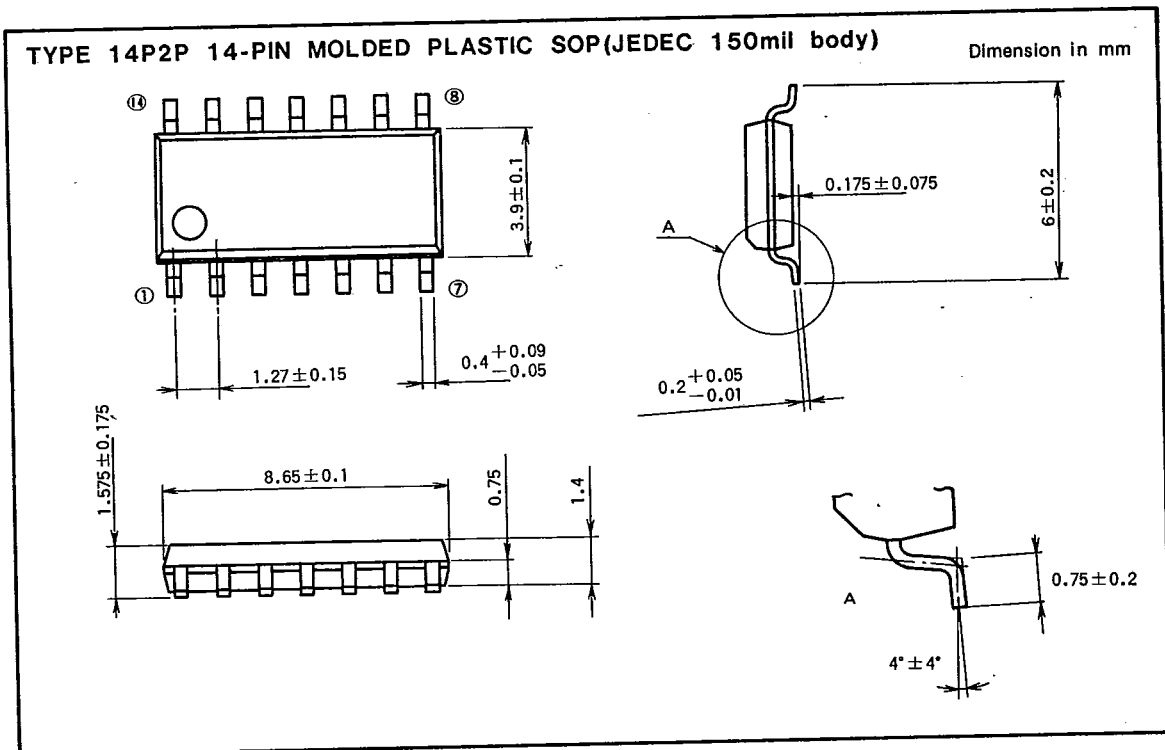

MITSUBISHI HIGH SPEED CMOS  
PACKAGE OUTLINES

6249827 MITSUBISHI (DGTL LOGIC)

91D 12854 D T-90-20

