



H22A1 H22A2 H22A3 Phototransistor Optical Interrupter Switch

Features

- No Contact Sensing
- 1mm Aperture
- High $I_{C(ON)}$
- PCB mount
- Transistor output
- RoHS compliant 

Description

The H22AX products consist of an infrared light emitting diode coupled to an NPN silicon phototransistor packaged in a injection molded housing. The package is designed to optimize the mechanical resolution, coupling efficiency, ambient light rejection, and reliability. Inserting/removing an opaque material into the gap when the LED is operating, switches the transistor on/off.

Package Dimensions

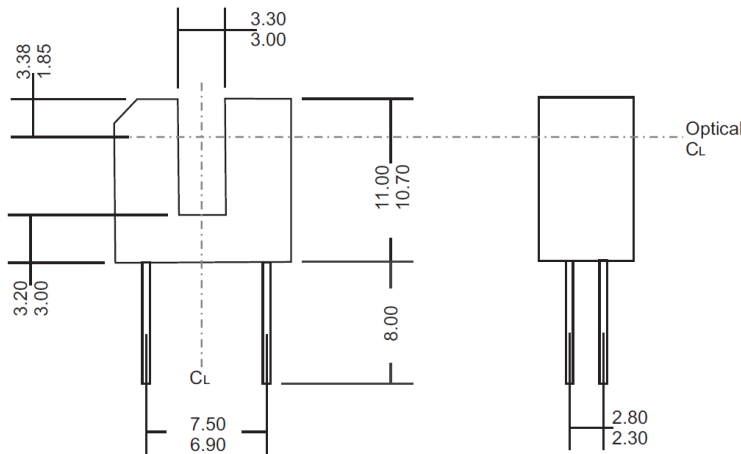
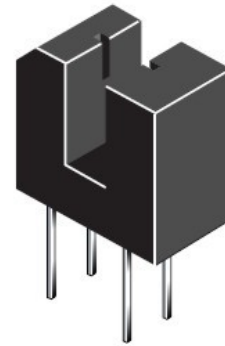
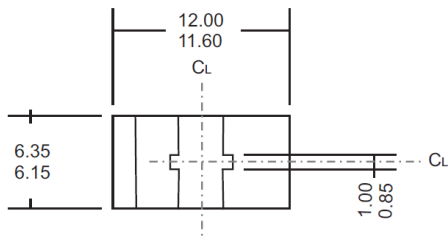

Schematic

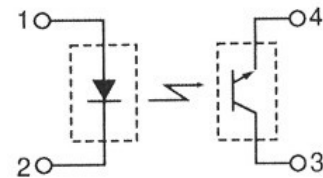

Pin 1 Anode
Pin 2 Cathode
Pin 3 Collector
Pin 4 Emitter

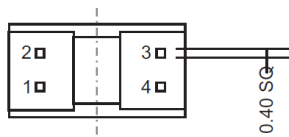

Notes

1. Dimensions for all drawings are in millimeters.
2. Tolerance of +/- 0.25 on all non nominal dimensions unless otherwise specified

H22A1 H22A2 H22A3 —Phototransistor Optical Interrupter Switch

Absolute Maximum Ratings ($T_A = 25^\circ\text{C}$ unless otherwise specified)

Stresses exceeding the absolute maximum ratings may damage the device. The device may not function or be operable above the recommended operating conditions and stressing the parts to these levels is not recommended. In Addition, extended exposure to stresses above the recommended operating conditions may affect device reliability. The absolute maximum ratings are stress ratings only.

Symbol	Parameter	Rating	Units
T_{OPR}	Operating Temperature	-55 to +100	$^\circ\text{C}$
T_{STG}	Storage Temperature	-55 to +100	$^\circ\text{C}$
T_{SOL-I}	Soldering Temperature (Iron) ^(3,4,5)	240 for 5 sec	$^\circ\text{C}$
T_{SOL-F}	Soldering Temperature (Flow) ^(3,4)	260 for 10 sec	$^\circ\text{C}$
Emitter			
I_F	Continuous Forward Current ⁽⁶⁾	60	mA
V_R	Reverse Voltage	6	V
P_D	Power Dissipation ⁽¹⁾	100	mW
Sensor			
V_{CEO}	Collector-Emitter Voltage	30	V
V_{ECO}	Emitter-Collector Voltage	4.5	V
P_D	Power Dissipation ⁽²⁾	150	mW

Notes:

- Derate power dissipation linearly 1.33 mW/ $^\circ\text{C}$ above 25 $^\circ\text{C}$.
- Derate power dissipation linearly 2.00 mW/ $^\circ\text{C}$ above 25 $^\circ\text{C}$.
- RMA Flux is recommended.
- Methanol or isopropyl alcohols are recommended as cleaning agents.
- Soldering iron tip 1.6mm from housing.
- As long as leads are not under stress or spring tension

Electrical/Optical Characteristics ($T_A = 25^\circ\text{C}$)

EMITTER						
Symbol	Parameter	Test Conditions	Min.	Typ.	Max.	Units
V_F	Forward Voltage	$I_F = 60\text{mA}$			1.7	V
V_R	Reverse Breakdown Voltage	$I_R = 10\mu\text{A}$	6			V
SENSOR						
Symbol	Parameter	Test Conditions	Min.	Typ.	Max.	Units
BV_{CEO}	Collector-Emitter Breakdown Voltage	$I_C = 1\text{mA}, E_e = 0$	30			V
BV_{ECO}	Emitter-Collector Breakdown Voltage	$I_{EC} = 100\mu\text{A}, E_e = 0$	6			V
I_{CEO}	Collector-Emitter Leakage	$V_{CE} = 25\text{V}, E_e = 0$			100	nA

Electrical/Optical Characteristics Cont. ($T_A = 25^{\circ}C$)

COUPLED						
Symbol	Parameter	Test Conditions	Min.	Typ.	Max.	Units
$t_{(ON)}$	Turn-on Time	$I_F = 30mA, V_{CC} = 5V, R_L = 2.5k\Omega$		8		μs
$t_{(OFF)}$	Turn-Off Time	$I_F = 30mA, V_{CC} = 5V, R_L = 2.5k\Omega$		50		μs

ON-STATE COLLECTOR CURRENT						
Symbol	Device	Test Conditions	Min.	Typ.	Max.	Units
$I_C (ON)$	H22A1	$I_F = 5mA, V_{CE} = 5V$	0.15			mA
	H22A2		0.30			
	H22A3		0.60			
	H22A1	$I_F = 20mA, V_{CE} = 5V$	1.0			mA
	H22A2		2.0			
	H22A3		4.0			
	H22A1	$I_F = 30mA, V_{CE} = 5V$	1.9			mA
	H22A2		3			
	H22A3		5.5			

COLLECTOR CURRENT SATURATION VOLTAGE						
Symbol	Device	Test Conditions	Min.	Typ.	Max.	Units
$V_{CE (SAT)}$	H22A1, H22A2, H22A3,	$I_C = 1.8mA, I_F = 20mA$			0.40	V
					0.40	V

Typical Performance Characteristics

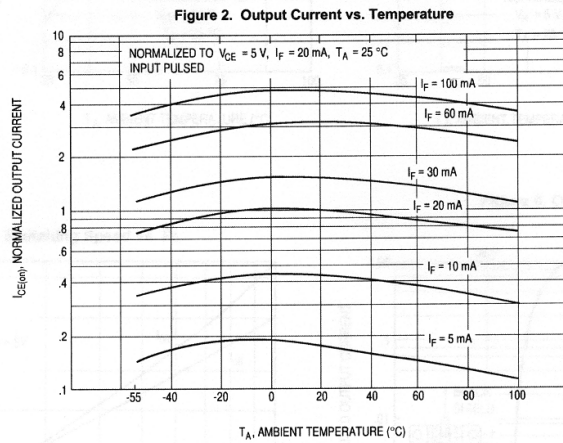
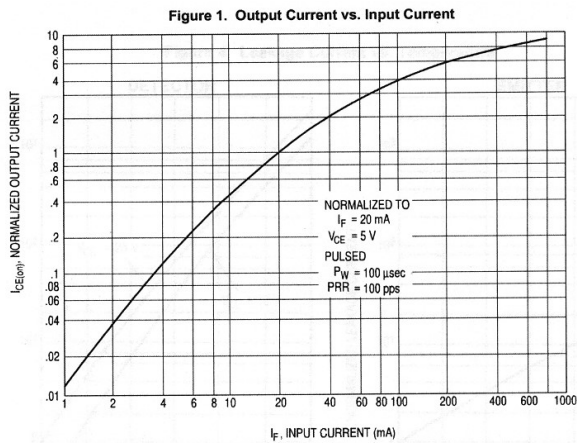

Typical Performance Characteristics

Figure 3. $V_{CE(SAT)}$ vs. Temperature

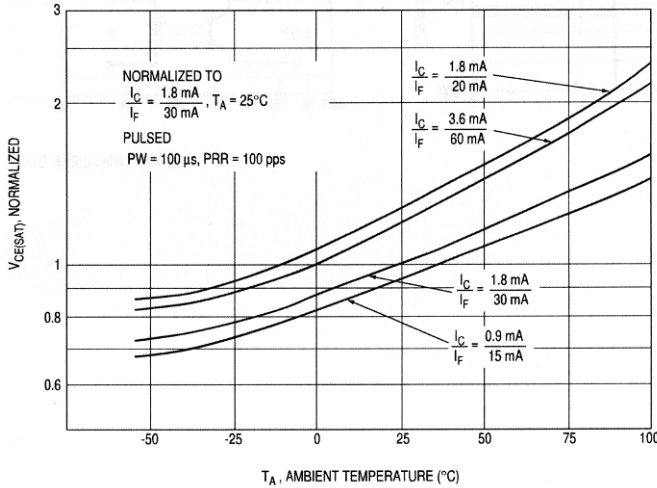

Figure 4. Leakage Current vs. Temperature

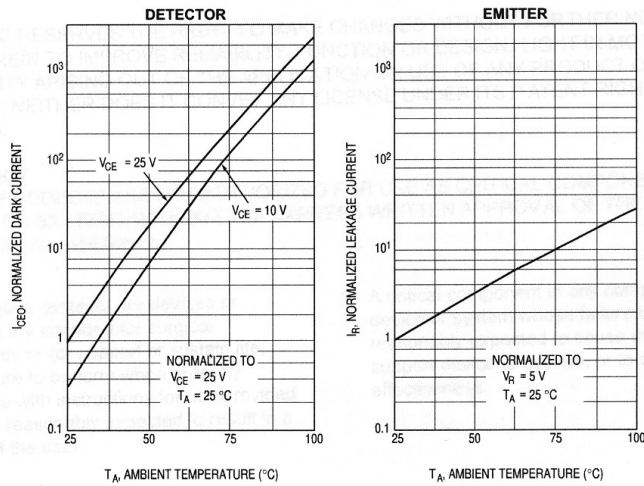

Figure 5. Switching Speed vs. R_L

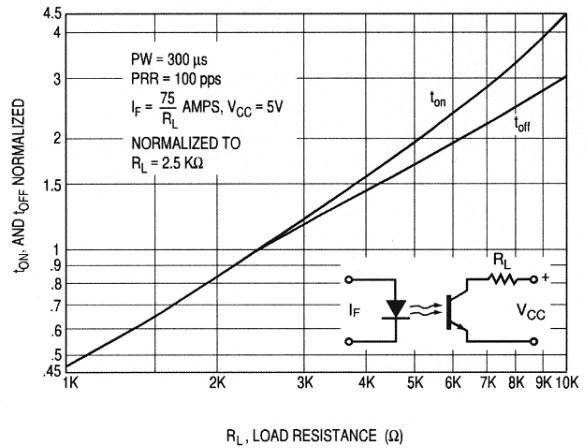
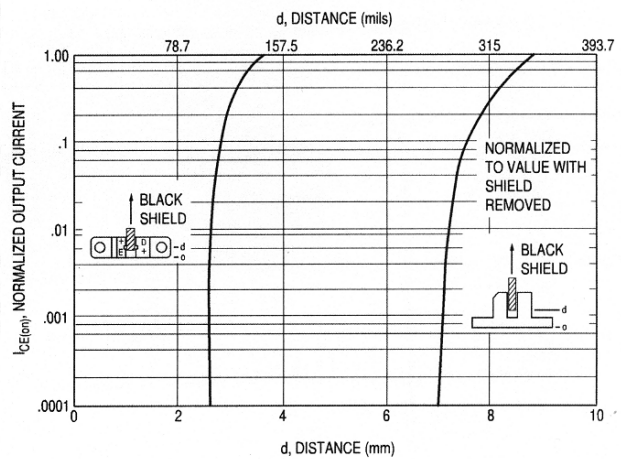

Figure 6. Output Current vs. Distance



DISCLAIMER

LIGHT IN MOTION LLC RESERVES THE RIGHT TO MAKE CHANGES WITHOUT FURTHER NOTICE TO ANY PRODUCTS HEREIN TO IMPROVE RELIABILITY, FUNCTION OR DESIGN. LIGHT IN MOTION DOES NOT ASSUME ANY LIABILITY ARISING OUT OF THE APPLICATION OR USE OF ANY PRODUCT OR CIRCUIT DESCRIBED HEREIN; NEITHER DOES IT CONVEY ANY LICENSE UNDER ITS PATENT RIGHTS, NOR THE RIGHTS OF OTHERS.

LIFE SUPPORT POLICY

LIGHT IN MOTION'S PRODUCTS ARE NOT AUTHORIZED FOR USE AS CRITICAL COMPONENTS IN LIFE SUPPORT DEVICES OR SYSTEMS WITHOUT THE EXPRESS WRITTEN APPROVAL OF THE PRESIDENT OF LIGHT IN MOTION LLC.

As used herein:

1. Life support devices or systems are devices or systems which, (a) are intended for surgical implant into the body, or (b) support or sustain life, and (c) whose failure to perform when properly used in accordance with instructions for use provided in the labeling, can be reasonably expected to result in a significant injury of the user.
2. A critical component in any component of a life support device or system whose failure to perform can be reasonably expected to cause the failure of the life support device or system, or to affect its safety or effectiveness.