

## LM8305—STN LCD Display Bias Voltage Source

### General Description

The LM8305M contains five buffered voltage sources to provide the voltage ratios required to drive a standard STN LCD display panel using a time-multiplexed voltage waveform to activate, or deactivate, a pixel once every picture frame. The internal resistor array features a binary weighted array to allow the user to select the proper ratio for the display being driven. The user can use an external resistor to set the ratio, if desired.

The LM8305 has a maximum operating supply voltage of 50V to support higher multiplexing rates.

The LM8305 also features an internal high side PNP switch, and an independent voltage comparator with an internal bandgap reference.

### Features

- High operating voltages, 50V maximum
- Internal resistor array with binary weighting
- Ratios from 1/6 to 1/37
- Optional external resistors
- High-side PNP switch from  $V_{CC}$
- Separate voltage comparator circuit with band-gap voltage reference
- Surface mount 24-pin package

### Typical Application

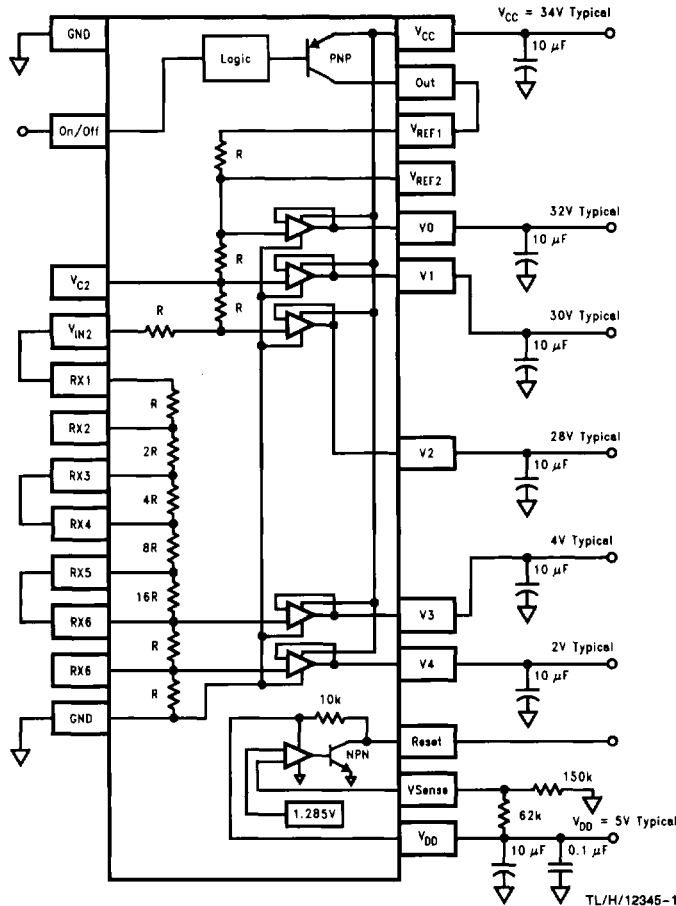

### Connection Diagram

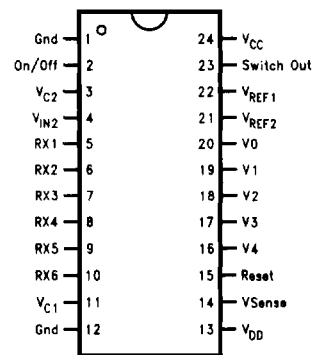

TL/H/12345-2

Top View

See NS Package Number M24B  
Order Number LM8305M