

## Unity gain level programmable low power compandor

NE/SA577

## DESCRIPTION

The NE/SA577 is a unity gain level programmable compandor designed for low power applications. The NE577 is internally configured as an expander and a compressor to minimize external component count.

The NE577 is available in a 14-pin plastic DIP and SO packages.

## FEATURES

- Operating voltage range: 1.8V to 7V
- Low power consumption (1.4mA @ 3.6V)
- 0dB level programmable (10mV<sub>RMS</sub> to 1.0V<sub>RMS</sub>)
- Over 90dB of dynamic range
- Wide input/output swing capability (rail-to-rail)
- Low external component count
- SA577 meets cellular radio specifications
- ESD hardened

## PIN CONFIGURATION

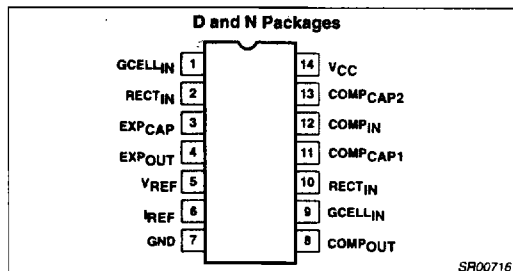

Figure 1. Pin Configuration

## APPLICATIONS

- High performance portable communications
- Cellular radio
- Cordless telephone
- Consumer audio
- Wireless microphones
- Modems
- Electric organs
- Hearing aids
- Automatic level control (ALC)

## ORDERING INFORMATION

DESCRIPTION	TEMPERATURE RANGE	ORDER CODE	DWG #
14-Pin Plastic Dual In-Line Package (DIP)	0 to +70°C	NE577N	SOT27-1
14-Pin Plastic Small Outline (SO)	0 to +70°C	NE577D	SOT108-1
14-Pin Plastic Dual In-Line Package (DIP)	-40 to +85°C	SA577N	SOT27-1
14-Pin Plastic Small Outline (SO)	-40 to +85°C	SA577D	SOT108-1

## ABSOLUTE MAXIMUM RATINGS

SYMBOL	PARAMETER	RATING		UNITS
		NE577	SA577	
V <sub>CC</sub>	Supply voltage	8	8	V
T <sub>A</sub>	Operating ambient temperature range	0 to +70	-40 to +85	°C
T <sub>STG</sub>	Storage temperature range	-65 to +150	-65 to +150	°C
θ <sub>JA</sub>	Thermal impedance	DIP	90	°C/W
		SO	125	°C/W

## Unity gain level programmable low power compandor

NE/SA577

**ELECTRICAL CHARACTERISTICS**

$T_A = 25^\circ\text{C}$ ,  $V_{CC} = 3.6\text{VDC}$ , compandor 0dB level =  $-20\text{dBV} = 100\text{mV}_{\text{RMS}}$ , output load  $R_L = 10\text{k}\Omega$ , Freq = 1kHz, unless otherwise specified. R1, R2 and R3 are 1% resistors.

SYMBOL	PARAMETER	TEST CONDITIONS	LIMITS			UNITS
			NE/SA577			
			MIN	TYP	MAX	
$V_{CC}$	Supply voltage <sup>1</sup>		2	3.6	7	V
$I_{CC}$	Supply current	No signal $R_2 = 100\text{k}\Omega$		1.4	2	mA
$V_{REF}$	Reference voltage <sup>2</sup>	$V_{CC} = 3.6\text{V}$	1.7	1.8	1.9	V
$R_L$	Summing amp output load		10			k $\Omega$
THD	Total harmonic distortion	1kHz, 0dB, BW = 3.5kHz		0.25	1.5	%
$E_{NO}$	Expander output noise voltage	BW = 20kHz, $R_S = 0\Omega$		10	25	$\mu\text{V}$
0dB	Unity gain level	0dB at 1kHz	-1.5	0.18	1.5	dB
	Programmable range <sup>3</sup>	$R1 = R3 = 18.7\text{k}\Omega$ , $R2 = 24.3\text{k}\Omega$		0		dBV
		$R1 = R3 = 22.6\text{k}\Omega$ , $R2 = 100\text{k}\Omega$		-10		
		$R1 = R3 = 7.15\text{k}\Omega$ , $R2 = 100\text{k}\Omega$		-20		
		$R1 = R3 = 1.33\text{k}\Omega$ , $R2 = 200\text{k}\Omega$		-40		
$V_{OS}$	Output voltage offset	No signal	-150	1	150	mV
	Expander output DC shift	No signal to 0dB	-100	7	100	mV
	Tracking error relative to 0dB output	-20dB expander	-1.0	0.3	1.0	dB
	Crosstalk, COMP to EXP	1kHz, 0dB, $C_{REF} = 10\mu\text{F}$		-80	-65	dB
$V_O$	Output swing low			0.2		V
	Output swing high			$V_{CC} - 0.2$		

**NOTE:**

1. Operation down to  $V_{CC} = 1.8\text{V}$  is possible, see application note AN1762.
2. Reference voltage,  $V_{REF}$  is typically at  $1/2 V_{CC}$ .
3. Unity gain level can be adjusted CONTINUOUSLY between  $-40\text{dBV} = 10\text{mV}_{\text{RMS}}$  and  $0\text{dBV} = 1.0\text{V}_{\text{RMS}}$ . For details see application note AN1762.

Unity gain level programmable low power compandor

NE/SA577

**BLOCK DIAGRAM and TEST AND APPLICATION CIRCUIT**

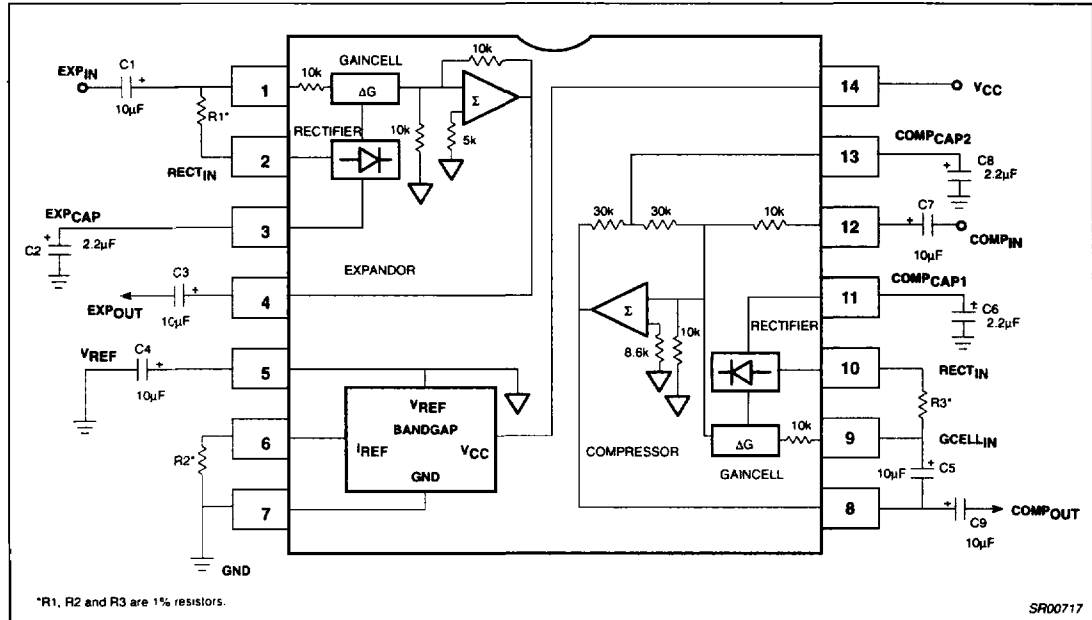

Figure 2. Block Diagram and Test and Application Circuit

# Unity gain level programmable low power compandor

NE/SA577

## TYPICAL PERFORMANCE CHARACTERISTICS

$V_{CC} = 3.6V$ ,  $T_A = 25^\circ C$ ,  $R_1=R_3=7.15k\Omega$ ,  $R_2=100k\Omega$ , 0dB level = 100mV, Freq. = 1kHz

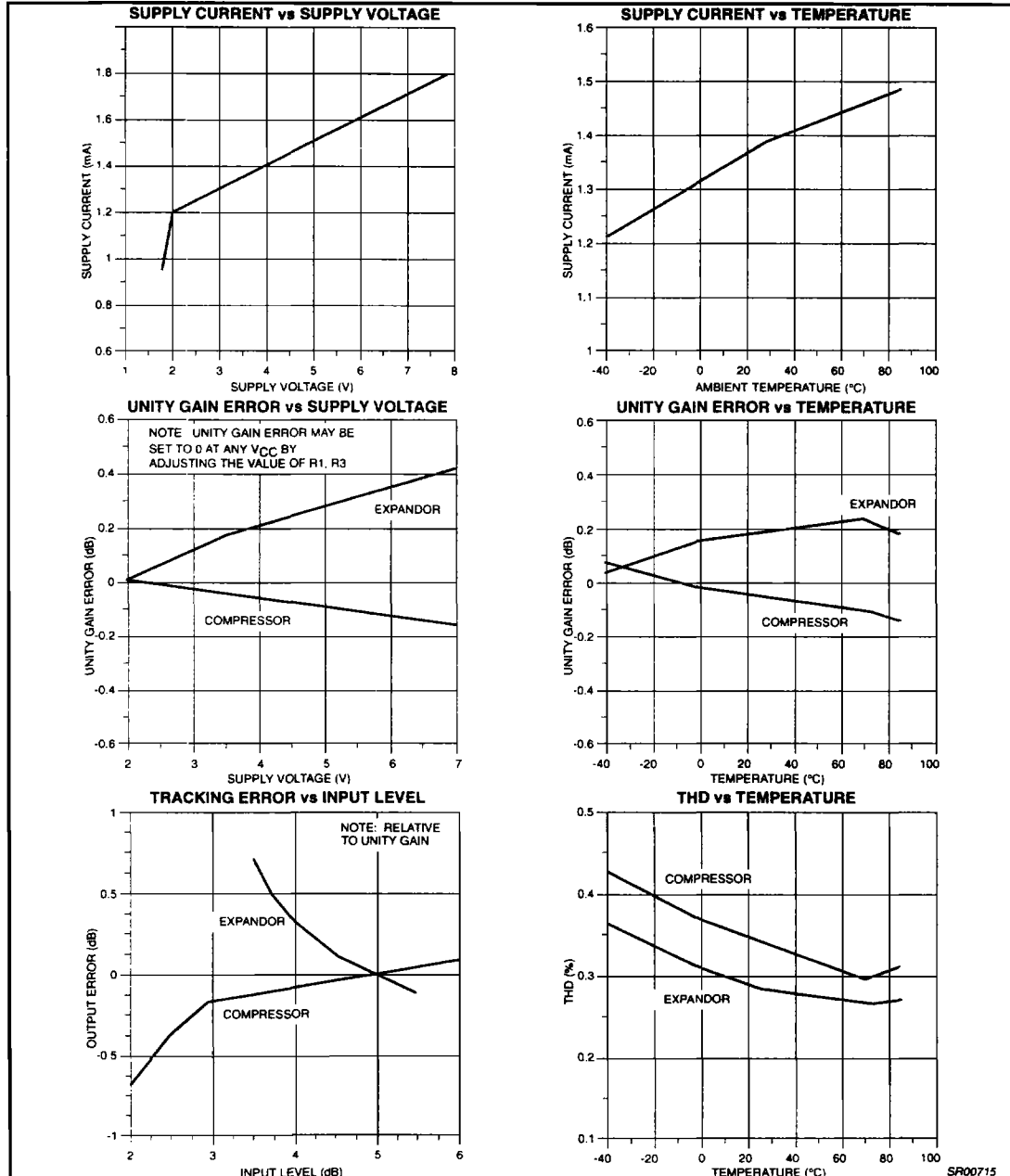

Figure 3. Typical Performance Characteristics

SR00715